

TECHNICAL MANUAL

OPERATOR'S MANUAL

FOR

**CARRIER, PERSONNEL, FULL TRACKED, ARMORED M113A3
2350-01-219-7577 (EIC AEY)**

**CARRIER, COMMAND POST, LIGHT TRACKED M577A3
2350-01-369-6085 (EIC AE7)**

**CARRIER, SMOKE GENERATOR, FULL TRACKED M1059A3
2350-01-369-6083 (EIC AFA)**

**CARRIER, MORTAR, 120-MM M121, SELF-PROPELLED M1064A3
2350-01-369-6082 (EIC AE8)**

**CARRIER, STANDARDIZED INTEGRATED COMMAND POST SYSTEM
(SICPS) M1068A3
2350-01-369-6086 (EIC AFC)**

**CARRIER, MECHANIZED SMOKE OBSCURANT M58
2350-01-418-6654 (EIC 5CG)**

SUPERSEDURE NOTICE — This manual supersedes TM 9-2350-277-10 dated 25 July 1994, including all changes.

DISTRIBUTION STATEMENT A — Approved for public release; distribution is unlimited.

HEADQUARTERS, DEPARTMENT OF THE ARMY

January 2001

WARNING SUMMARY

WARNING SUMMARY

This section provides a summary of all critical safety information in this TM. It includes general WARNINGS not found in the Work Package (WP) procedures, hazardous materials WARNINGS, and a list of critical WARNINGS extracted from the WPs.

Prior to starting any WP procedure, the WARNINGS included in the text for that WP must be reviewed and understood.

GENERAL WARNINGS NOT FOUND IN WP PROCEDURES

The following WARNINGS are general safety statements. They are not unique to any specific procedures and, therefore, do not appear elsewhere in this TM. All personnel operating this equipment or working near this equipment must understand and continually observe the precautions in these WARNINGS.

WARNING

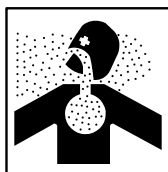

Engine and personnel heater exhaust fumes are toxic. Severe exposure can kill or seriously injure personnel. NBC mask will not protect personnel from engine exhaust and carbon monoxide.

Symptoms of exhaust fume poisoning include dizziness, drowsiness, headache, and loss of muscle control. If anyone shows signs of exhaust poisoning, evacuate all personnel from vehicle to an area with fresh air. Immediately seek medical help. Keep personnel warm, calm, and inactive. Provide artificial respiration to anyone who stops breathing.

The smoke from smoke generators is not acutely toxic and does not contain significant carbon monoxide. However, diesel fuel particulates that make up smoke will make personnel nauseous. The NBC mask will filter out diesel particulates and may help to reduce nausea. However, NBC mask will also filter out diesel exhaust, which is the only warning of carbon monoxide hazard from engine or personnel heater exhaust exposure. Exposure to high levels of carbon monoxide can kill personnel within minutes. Whenever personnel are affected by diesel exhaust or vapors, remove all personnel to an area with fresh air as soon as tactical situation permits.

To protect yourself and other personnel from carbon monoxide poisoning, obey the following rules:

- Do not run heater or engine indoors unless you have very good air flow.
- Do not idle engine for long periods of time unless there is very good air flow.
- Do not start engine or personnel heater if any power plant access covers, plates, or doors are open.
- Be alert at all times for smell of exhaust fumes. If fumes are noticed inside vehicle, immediately turn on vent fans and open all hatch covers and ramp access door.

Remember: The best defense against exhaust gas poisoning is good, fresh air flow.

WARNING SUMMARY (cont)

WARNING



Noise from vehicle or weapons can damage hearing of soldiers in vehicle. All personnel in vehicle must wear **DOUBLE HEARING PROTECTION** when guns, missile, or vehicle is operated. Hearing protection devices must be properly worn to provide effective protection.

If **DOUBLE HEARING PROTECTION** is not worn, the safe level of noise exposure will be exceeded in a short time. Hearing loss occurs gradually. Each noise exposure that exceeds the ear protection guidelines below will cause temporary hearing loss. Over time, the loss in hearing will become permanent. Plan each day's operation, and be sure all crew and riders have the required ear protectors. Spare foam earplugs must be available.

DEFINITIONS:

- | | |
|----------------------------------|---|
| DH-132 | The "tankers helmet," also called "CVC" helmet. Must be in good condition, with liner and earcups fitted tightly, and chin strap worn at all times. |
| Earplugs | Only standard issue earplugs are acceptable. All of the dismounted squad soldiers must be trained in how to use them. Since they may be removed and lost, spares must be carried. |
| Double Hearing Protection | Use of two hearing protection devices at the same time. For this carrier, use earplugs with the DH-132 helmet. |

EAR PROTECTION GUIDELINES

Driver

- Must wear DH-132 helmet at all times.
- Must wear DH-132 helmet plus earplugs for operations exceeding 14 miles (23 km) in 24 hours.
- Must close hatch immediately if .50 caliber machine gun is fired over front part of carrier.
- Hatch may remain open and locked during carrier operation.

Commander

- Must wear DH-132 helmet at all times.
- Must wear DH-132 helmet plus earplugs for all operations exceeding 14 miles (23 km) in 24 hours.
- Hatch may be locked open at all times.

Squad Members

- Must wear helmet and ear plugs at all times.

Use of Radio with Earplugs

- Wearing foam earplugs in addition to your DH-132 helmet can actually improve your ability to hear the radio in a high level noise area. **DO NOT** remove the earplugs to use the radio.

WARNING SUMMARY (cont)

WARNING

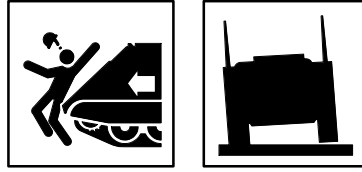

Drivers below 62 inches (1.57 meters) in height may not have adequate open hatch vision while properly operating the vehicle controls. Accidents caused from loss of vehicle control could result in death or injury to personnel. Before assuming vehicle driver responsibilities, it must be verified during drivers training that without the use of aids the driver can see the feet of a ground guide 30 feet (9.14 meters) in front of the vehicle and be able to operate all driver controls to their maximum potential.

LIST OF WARNINGS IN WP PROCEDURES

This list includes all the critical WARNINGS in the WP procedures. Study these WARNINGS carefully. They can save your life and the lives of soldiers with whom you work.

WARNING

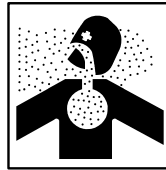

Failure to open ventilator, when operating carrier with all hatches closed, will result in a serious lack of oxygen.

WARNING



If antennas touch electric power lines, you could be electrocuted. Make sure radio antennas have clearance when carrier is operating near electric power lines.

WARNING

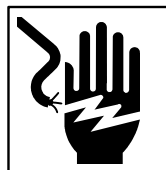

When using external power, ensure proper grounding procedures are followed. Failure to do so may result in personnel injury and/or damage to the equipment. See TM 11-7010-256-12&P for installing surface wire grounding system.

WARNING SUMMARY (cont)

WARNING



HIGH VOLTAGE is used in the operation of this equipment.

DEATH ON CONTACT may result if personnel fail to observe safety precautions.

NEVER work on equipment unless at least one other person familiar with the operation and hazards of the equipment is nearby. That person should also be competent in giving first aid. When an operator helps a technician, that operator must be warned about dangerous areas.

SHUT OFF POWER supply to equipment before beginning work. When working inside equipment with power off, take special care to ground every capacitor likely to hold a dangerous potential.

BE CAREFUL not to contact high-voltage connections when installing or operating this equipment.

KEEP one hand away from the equipment to reduce the hazard of current flowing through life-sustaining organs of the body.

WARNING



Inspect heater fuel lines for leaks. **DO NOT** operate heater with a bad fuel line. You could be badly burned.

WARNING

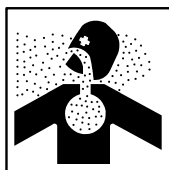

Heater exhaust fumes contain deadly poisonous gases. Severe exposure can cause death or permanent brain damage. Turn heater off if you smell or suspect exhaust gas inside personnel compartment.

WARNING SUMMARY (cont)

WARNING



Do not apply full body weight to seat unless vertical control handle is engaged in one of the holes in the pedestal. If vertical control handle is not properly engaged, seat could fall and personnel could be injured.

WARNING



Ramp access door is heavy. It can swing and injure personnel. Make sure no one is in the area of ramp access door when it is opening. Secure door hook before you go out.

WARNING



The use of the left hand to grasp and close the ramp access door will expose the thumb to being extended beyond the door's edge and possible amputation when the door is pulled closed. When using the left hand, use only the center of the handhold and be aware of thumb position.

WARNING

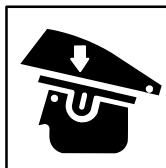

Driver's hatch cover could fall and injure you. Keep your head and hands clear when you open or close driver's hatch cover.

WARNING SUMMARY (cont)

WARNING



Cargo hatch cover is heavy. It can fall and injure you. When opening or closing cover, keep your head clear of the cover and keep your hands clear of the rim.

WARNING



Commander's hatch cover could fall and injure you. Keep hands clear when you open or close commander's hatch cover.

WARNING



Power plant access door could fall and injure you. Install door brace before you work under door.

WARNING

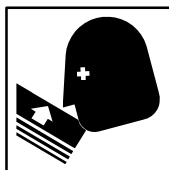

Power plant access door may spring open. Soldiers can be injured. When opening, stay out of door path.

WARNING SUMMARY (cont)

WARNING



Lowering ramp could injure personnel. Make sure no one is in ramp zone before you lower ramp.

Check ramp door operation. Make sure hinges work right and door can be secured tightly with the lock.

Check ramp operations by opening and lowering.

Unlocked ramp can fall open suddenly. Personnel can be killed or injured. Check that ramp cable is connected with no slack. Ramp system and hull can get damaged if ramp unlocks when carrier is in operation. Do not operate carrier if locks do not secure ramp properly. Keep away from ramps that have come open during carrier operation.

WARNING



Do not step on service brake while entering and exiting carrier. Failure to do so could cause personnel inside and outside the carrier to get injured or killed.

WARNING



Seat can spring up and hit you when vertical control handle is released. Make sure you are sitting in the seat before releasing vertical control handle.

WARNING



Sudden carrier movement can throw you out of your seat. Wear seat belt while carrier is in motion. Do not use any seat with missing or inoperative seat belt.

WARNING SUMMARY (cont)

WARNING



Do not step on parking brake handle when entering or leaving a running vehicle. The vehicle may pivot and cause injury or death.

WARNING



Engine exhaust gas is deadly poison. Make sure power plant access panels are closed tight before you start engine.

WARNING



If transmission controller is set to SL position, and steering wheel is not centered to engage locking pin, carrier may pivot steer and injure personnel. Steering wheel must be centered when starting engine.

WARNING



If batteries are frozen, do not attempt to slave start vehicle. Explosion can occur causing injury to personnel and damage to equipment.

WARNING SUMMARY (cont)

WARNING



Do not park live vehicle head to head with dead vehicle. Either vehicle could jump forward. Stay clear of area between vehicles during starting operations.

WARNING



Electrical slave cable can be improperly connected causing electrical spark or fire. Personnel can be killed or injured. Equipment can be damaged. Match connector guide lug and cable prongs with receptacle hole.

WARNING



Electric sparking can burn you. Equipment can be damaged. Make sure to disconnect slave cable carefully not to cause any sparks.

WARNING



Carrier noise can cause permanent hearing damage. Double hearing protection must be worn. See warning in front of manual.

WARNING SUMMARY (cont)

WARNING



Vehicle operation during hot weather may result in heat stress to crew members. Crew members should limit their exposure to high temperature and humidity based on TB MED 507. Open door for ventilation, if appropriate.

WARNING

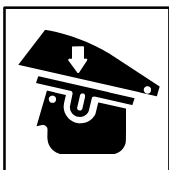

Unlatched hatch cover could swing and injure personnel. Make sure hatches are latched and secure.

WARNING



Do not attempt to change carrier forward or reverse movement by shifting until carrier comes to a complete stop. Above four miles per hour, if you attempt to shift into reverse (or forward), the carrier will continue in the direction you are moving when you attempted to make the change. Failure to follow the above instructions could result in injury or death to personnel and destruction of equipment or property.

WARNING



Brake pedal is very sensitive. Applying brake hard can cause carrier to stop suddenly. Personnel could be injured. Apply brake pressure lightly and with caution.

WARNING SUMMARY (cont)

WARNING

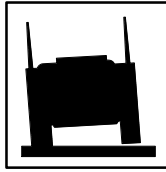

When a track vehicle gets out of control and overturns, it is safer to stay in the vehicle than to try to get out while the vehicle is still moving. You may receive slight injuries from being thrown against metal parts; but if you try to leave the vehicle, it may roll over and crush you. Once the vehicle stops moving, get out as fast as possible because spilled fuel and oil may catch on fire. The first thing the driver should do in such an emergency is shut off the engine and turn off the MASTER SWITCH to minimize the fire hazard.

WARNING



Operating carrier in reverse is dangerous due to limited vision and reversed steering. Always post ground guides before you back up.

WARNING



Carrier can pivot steer when transmission controller is in SL position and steering lock pin is not engaged. Personnel can be killed or injured. Make sure transmission controller is in SL and steering wheel is centered to engage steering lock pin (steering locked indicator light should be ON) unless carrier is to be steered.

WARNING



Diesel fuel can catch fire and burn you. Do not smoke or allow open flame near carrier when fueling.

WARNING SUMMARY (cont)

WARNING



Sparks from static electricity can cause a fire or explosion. Metal nozzle must touch metal in filler neck when fueling carrier or ground wire must be installed to carrier being fueled.

WARNING

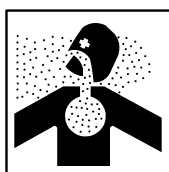

Exhaust from personnel heater can kill you. Do not breathe exhaust gases. If you detect or suspect fumes, turn heater off and open all hatches right away. See warning in the front of this manual.

WARNING



Ammunition can explode and kill you. Do not start heater until ammunition and combustible/explosive materials are properly stored at least 30 inches from heater vents. Combustible materials must be stored 12 inches or more from metal surfaces of heater.

WARNING

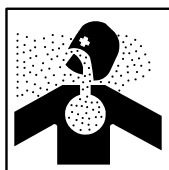

Lack of air in carrier can make personnel dizzy. When operating carrier with hatch covers closed, make sure personnel compartment ventilator is open.

WARNING SUMMARY (cont)

WARNING



Exposure to CO2 can cause dizziness, shortness of breath, muscular weakness. Stop engine before you discharge CO2. If CO2 is discharged, open hatch covers, or get all personnel out of carrier.

WARNING



Engine fan can blow away CO2 before fire is extinguished. Personnel can get burned. Equipment can get damaged. Stop engine before you operate fire extinguisher.

WARNING



Fire extinguisher CO2 can cause suffocation and/or severe burns. Handle the fire extinguisher carefully. Do not bang or drop cylinder.

WARNING



Do not touch cone when using extinguisher. Hands will be severely burned.

WARNING SUMMARY (cont)

WARNING



Remove 2.7 volt battery from battery compartment before connecting driver's night vision power cable. The 2.7 volt battery may explode if not removed before the connection is made. Personnel may be injured if battery explodes.

WARNING



Trim vane is heavy. Personnel can be injured and equipment damaged. Have helper assist. Open and lower trim vane slowly. Avoid being caught between trim vane and hull or ground.

WARNING



Unsecured hatch cover could move and hit you in the head. When hatch is open, secure latch with locking pin.

WARNING



Unsecured hatch cover could move and hit you in the head. When hatch is closed, secure hatch with exterior locknut.

WARNING SUMMARY (cont)

WARNING



Hanging loads, heavy parts, and overhead equipment can fall unexpectedly and kill or injure you.

Stay clear of hanging loads, heavy parts, and overhead equipment. Use correct lifting devices. Always have helper guide heavy parts and equipment.

WARNING



When stowing the eave poles, secure the split sections together. The inner section can extend and be lost or cause injury to personnel.

WARNING



Sudden carrier movement can injure personnel. Do not remove foot from brake.

WARNING

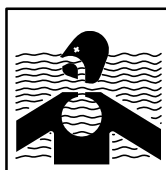

When water depth is unknown or deeper than 40 inches (3.4 feet), do not attempt to ford stream. Carrier may sink and personnel could drown.

WARNING SUMMARY (cont)

WARNING



Personnel could be killed or injured if carrier moves with someone under it. Make sure engine is stopped, parking brake set, and carrier tracks blocked before crawling under carrier.

WARNING

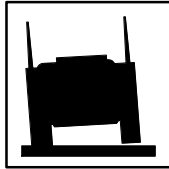

Carrier can roll over and kill or injure personnel. Avoid high speeds and sudden turns when driving on hills or rough terrain. Wear seat belts.

WARNING

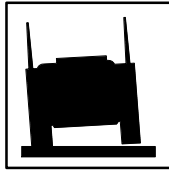

Carrier can roll over and kill or injure personnel. Do not drive on side slopes steeper than 30%.

WARNING



An inoperable/unsafe ramp can fall and kill you. Do not attempt to manually raise or lower an inoperable/unsafe ramp. Notify unit maintenance to raise or lower an inoperable/unsafe ramp.

WARNING SUMMARY (cont)

WARNING



A towed carrier does not have steering until it reaches 3 mph plus. Personnel can be killed or injured. Use tow bar or two tow cables and use brakes to stop carrier, when necessary.

WARNING



Steering and braking control are lost when final drive shafts are disconnected. Personnel can be killed or injured. Do not use tow cables when drive shafts have been disconnected.

WARNING



Carrier could roll and kill or injure personnel when final drive shafts are disconnected. Block carrier tracks and connect tow bar to disabled carrier and to tow vehicle before disconnecting drive shafts.

WARNING



Braking from high speeds when you tow with tow cables or tow bar can jackknife vehicles. Jackknife could injure personnel and damage vehicles. Do not tow at speeds over 15 mph (25 km/hr) with tow bar. Do not tow at speeds over 5 mph (8 km/hr) when in rough terrain, towing backward, or towing with tow cables.

WARNING SUMMARY (cont)

WARNING

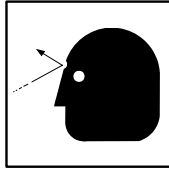

Tow cables can snap and injure personnel. Close all hatch covers before you use tow cables to tow carrier. Clear personnel out of danger area.

WARNING



A towed carrier does not have steering until it reaches 3 mph plus. Personnel can be killed or injured. Use tow bar or two tow cables and use brakes to stop carrier, when necessary.

WARNING

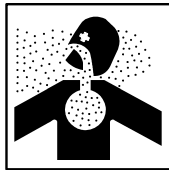

Filters and masks of the NBC system will not protect you against carbon monoxide, ammonia, acid, or solvent fumes. Be sure the carrier is properly ventilated. Do not let any filters of the NBC system get wet. Water will destroy their ability to take the deadly chemical and biological agents out of the air. Contaminated filters must be handled using adequate precautions and must be disposed of by trained personnel. If it is very cold outside, there is danger of frostbitten lungs from inhaling the cold air. Do not connect the hoses to your M42 mask canister until NBC system has been operating at least 15 minutes with the heater turned on.

WARNING



If it is very cold outside, there is danger of frostbitten lungs from inhaling cold air. Do not connect the hoses to your M42 mask canister until heater has run for at least 15 minutes.

WARNING SUMMARY (cont)

WARNING



Smoke grenades can explode and kill or injure personnel. Handle grenades with care. Do not drop or throw grenades. Do not use damaged grenades. Keep grenades away from electric sparks. Keep containers sealed until you are ready to use grenades.

WARNING



Heat could set off smoke grenades and kill or injure personnel. Do not place smoke grenades on hot surfaces.

WARNING



Electrical trouble could cause smoke grenades to launch and kill or injure personnel. Make sure ARM/OFF switch is OFF before you load smoke grenades. Do not place any part of your body in front of smoke grenade launchers.

WARNING



Smoke grenades explode and burn. Handle them with care. Except when using your hand to load grenade launcher, never put any part of your body in front of loaded launcher tubes. You could be killed or injured. Check that personnel are clear of firing lines when launching grenades.

WARNING SUMMARY (cont)

WARNING



If misfired smoke grenades launch during unloading, personnel in the area could be killed or injured. Keep carrier pointed down range until grenades are removed.

WARNING



Misfired smoke grenades could kill or injure personnel if mishandled. Do not attempt to move a dud grenade.

WARNING

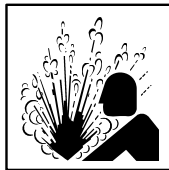

Hot radiator coolant can burn you. Use hand to remove cap only if cool to touch. Turn cap slowly to release pressure. Replace cap by pressing down and turning cap until tight.

WARNING



Benzene (benzol), paint thinner, gasoline, and diesel fuel oil can burn, poison soldiers, and damage equipment.

Use the approved cleaning agents.

WARNING SUMMARY (cont)

WARNING



Failure to set parking brake and block wheels can allow carrier to move and could result in personnel injury or death. Always set parking brake and block wheels before performing PMCS.

WARNING



Not having the correct track tension during inspection can cause you to not see defective track parts that could cause track failure and loss of vehicle control. Soldiers can be killed or injured.

Adjust track tension before inspecting track assembly and track shoes.

WARNING

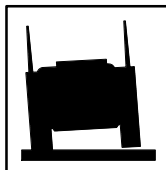

If you lose a track (break a track shoe or vehicle throws a track), extreme caution must be exercised in maintaining control. Immediately release accelerator and let the vehicle coast to a stop. Do not apply braking action, i.e., brake pedal, pivot, or any type of steering controls. This causes the vehicle to pull to the active or good track and could result in a rollover. It is absolutely necessary to apply braking action only, and we stress only, if the vehicle is approaching a ravine, a cliff, or if you perceive the outcome to be catastrophic, probably resulting in fatalities. When a rollover is imminent, all crewmembers should immediately withdraw inside the vehicle, tighten seat belts and hold onto a secure fixture, until the vehicle comes to a complete stop.

WARNING SUMMARY (cont)

WARNING



Failure to perform track PMCS and not repair or report to maintenance per technical manual procedures can allow you to operate the vehicle with defective track parts that could cause track failure and loss of vehicle control. Soldiers can be killed or injured.

Never operate a vehicle without performing the BEFORE mission PMCS track tension adjustment and track inspection per PMCS procedures in the technical manual. Repair or report problems to maintenance per technical manual instructions as outlined in PMCS.

WARNING



A fire can break out at any time. Personnel could be killed or injured. Equipment could be damaged. Make sure all fire extinguishers are ready to use before you operate carrier.

WARNING



Sticking or damaged linkages can cause carrier to crash. Personnel can be killed or injured. If accelerator pedal does not operate smoothly, or engine does not return to idle when accelerator pedal is released, do not drive carrier.

Loss of carrier control can cause carrier to crash. Personnel can be killed or injured. Avoid over steering at high speeds to prevent skidding or carrier upset. Use caution when turning on hills or side slopes.

WARNING



Make sure weapon is clear and safe before loading or testing, to prevent accidental firing of machine gun and injury to personnel.

WARNING SUMMARY (cont)

WARNING



All personnel within 75 feet (22.9 meters) of M1059A3 and M58 during operation must wear personnel hearing devices to prevent hearing damage. Contamination is likely, and loss of hearing could occur. Personnel inside carrier in motion, with smoke generator in operation, must wear double hearing protection. Limit exposure of high noise levels to six hours to prevent hearing damage. Use of yellow/white foam ear plugs is prohibited for personnel operating M1059A3 and M58 carrier.

WARNING



If TRANS OIL LOW PRESS warning light stays on, personnel can be injured and equipment can be damaged from erratic vehicle movement. Ensure all ground personnel are clear of the vehicle before engaging transmission. Apply and hold brakes before engaging transmission.

WARNING



Do not operate personnel heater if any fuel leak is found in heater or in fuel lines.

WARNING



Do not use heater during operation. Injury to personnel may occur.

WARNING SUMMARY (cont)

WARNING



Sudden carrier movement can throw you out of seat. Wear seat belts at all times when carrier is in motion, except when performing water operations.

WARNING



Hot parts can burn you. Let hot parts cool before you start work.

WARNING



Fuel is flammable. Always use in area with good air flow, away from heat or flames. Do not breathe fumes. If fuel gets on hands, wash them. If fuel gets in eyes, flush with water and get medical help. Keep fire extinguisher nearby.

WARNING



Lowering ramp could injure personnel. Make sure no one is in ramp zone before you lower ramp. If tactical situation permits, sound horn before lowering ramp.

WARNING SUMMARY (cont)

WARNING



Fire resistant hydraulic (FRH) fluid may contain Tricresyl Phosphate which, if taken internally, can produce paralysis. Hydraulic fluid may be absorbed through the skin. Wear long sleeves, gloves, goggles, and face shield. If FRH gets in eyes, wash them immediately and get medical aid immediately. If FRH gets on your skin, thoroughly wash with soap and water. Wash hands thoroughly prior to eating or smoking. Application of these measures is considered an effective control of the hazard.

WARNING



Make sure carrier is properly grounded before refueling. Fuel can catch fire and burn you. Wipe up spilled fuel.

WARNING



Final drive housings can heat up enough to burn you.

WARNING



Roadwheel hubs and idler wheel hubs can heat up enough to burn you.

WARNING SUMMARY (cont)

WARNING



Shock absorbers can heat up enough to burn you.

WARNING



Fuel lines may vibrate loose or crack during mortar firing. Fuel leaks can cause fumes or fires which cause serious bodily harm or death to personnel. If fuel leaks, STOP FIRING. Repair leaks or cracks, wipe up any excess fuel before you resume firing.

WARNING



Sparks from static electricity can cause a fire or explosion. Fuel cans should be removed before being filled. Metal nozzle must touch metal in filler neck when filling or ground wire must be attached to fuel can being filled. Fuel can catch fire and burn you. Do not smoke. Wipe up spilled fuel.

WARNING



Failure to decontaminate and wear protective clothing after NBC attack could result in serious health hazards to personnel. Do not service air cleaner or vent system after NBC attack until carrier has been decontaminated.

If NBC exposure is suspected, all air filter media should be handled by personnel wearing protective equipment. Consult your unit NBC officer or NBC NCO for appropriate handling or disposal instructions.

Unlatched hatch covers can swing and injure personnel. Make sure hatches are latched open or closed.

WARNING SUMMARY (cont)

WARNING

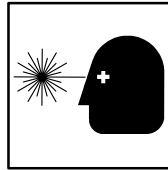

Do not look directly into infrared lights. You can damage your eyes. Do not touch lens. You can burn your fingers.

WARNING



HIGH VOLTAGE in the AN/VVS-2 can cause serious injury or death. To avoid accidents:

ALWAYS connect power cable to DNV **BEFORE** turning **MASTER SWITCH** and **DNV POWER** switch to **ON**.

ALWAYS wait at least two minutes **BEFORE** you disconnect power cable from periscope when turning **DNV POWER** switch and **MASTER SWITCH** to **OFF**.

NEVER disconnect power cable from DNV until image disappears from periscope screen.

NEVER touch end of cable. Voltage could exceed 16,000 volts.

WARNING

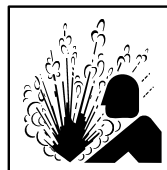

Don't smoke, have open flames, or make sparks around batteries, especially if the caps are off. Batteries can explode and cause injury or death.

Remove all jewelry such as rings, dog tags, bracelets, etc. If jewelry contacts battery terminals, a direct short will result in instant heating of metals, damage to equipment, and injury to personnel.

If batteries are frozen, do NOT attempt to slave start vehicle. Explosion can occur causing injury to personnel and damage to equipment.

WARNING SUMMARY (cont)

WARNING

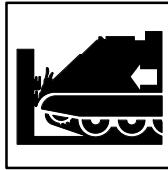

Do not shift to SL (Steering Lock) position at speeds above 5 mph. Loss of control at speeds above 5 mph could cause vehicle to crash.

WARNING

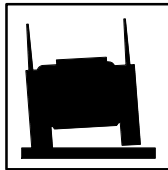

Improper number of track shoes may prevent track from being adjusted correctly, creating a safety hazard.

For carriers with new track, ensure there are 63 track shoes on the left side of carrier and 64 track shoes on the right side of carrier.

For carriers with old track, ensure there are 62 track shoes on the left side of carrier and 63 track shoes on the right side of carrier.

WARNING

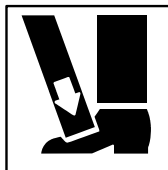

You could be injured if track swings out and hits you. Do not stand in front of track being broken.

WARNING

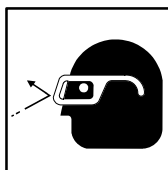

Always wear eye protection when using a hammer. Eye injury may result if metal chips contact eyes.

WARNING SUMMARY (cont)

WARNING



Track shoe bushing failure can cause track assembly failure and loss of vehicle control. Soldiers can be killed or injured.

Do not use excessive force that could damage the track shoe bushing while driving in the track pin during assembly.

WARNING

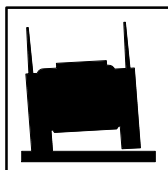

Do not use the crowbar on the track shoe pins to get leverage. Any scratches may cause the pin to break and cause the track assembly to fall off the vehicle while operating. This may kill soldiers and damage equipment.

WARNING



Not getting the bolt tight enough may result in death to personnel and damage to equipment if the end connectors fall off during movement of the vehicle. Use the wrench extension over the breaker bar to achieve more leverage when tightening the end connector bolt.

WARNING



Worn or damaged track components can cause track failure and loss of vehicle control. Soldiers can be killed or injured. If track components are not in satisfactory condition, do not operate vehicle.

WARNING SUMMARY (cont)

WARNING

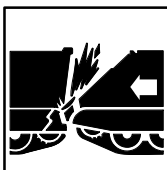

Loss of track end connector can cause track throw and loss of vehicle control. Soldiers can be killed or injured. Mark end connector bolts. Notify unit maintenance to torque bolts.

WARNING



Track shoe bushing failure due to improper angle of track during pin assembly can cause track assembly failure and loss of vehicle control. Soldiers can be killed or injured.

Make sure track is assembled with the right amount of angle or lift as shown below. Properly assembled track will lay flat. Incorrectly assembled track will bulge upward.

WARNING

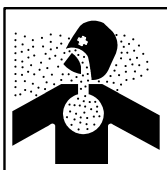

Engine exhaust fumes can kill you. Do not operate the carrier with access panels off. Make sure the panels are sealed tight. See warning in the front of this manual.

WARNING



Fuel is highly flammable and can catch fire quickly. Use extreme caution when working around fuel and keep all flames and sparks a minimum of 25 feet away. If fuel gets on your skin it can cause burns or rashes. Wash skin immediately with soap and water and seek medical attention.

WARNING SUMMARY (cont)

WARNING



Do not fill fuel can with smoke generator running, while smoking, or when near an open flame. Never overfill the fuel can or spill fuel. An explosion can be caused, and death or injury to personnel may result. If fuel is spilled, clean it up immediately.

WARNING

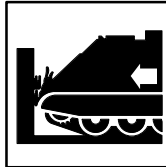

If the display becomes degraded while driving the vehicle, such as the presence of dead pixels (the very small dots that make up the display image) and/or video noise that prevents the driver from performing his mission, then immediately bring the vehicle to a safe stop to avoid collision. If the problem cannot be fixed, report the situation to higher level maintenance.

WARNING



The AUTO LEVEL and AUTO GAIN modes do not react instantly to rapidly changing scenery (shade to sun, sun to shade). The AUTO LEVEL and AUTO GAIN modes require one or two seconds to compensate. The automatic gain and level features will adjust faster than manual adjustments. If necessary, slow or stop vehicle.

WARNING



Before operating the vehicle, ensure that the DVE azimuth control is in the locked position. This will ensure that the DVE is looking straight ahead when operating the vehicle. Failure to do so may result in personnel injury and/or damage to the equipment.

WARNING SUMMARY (cont)

WARNING

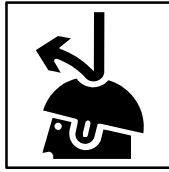

Helmets must always be worn when driving with the DVE installed. The DVE display should be removed from its mount when not in use for extended driving operations to minimize the risk of head strike injuries.

FIRST AID

For first aid information, see FM 4-25.11.

CHANGE
NO. 4

HEADQUARTERS
DEPARTMENT OF THE ARMY
WASHINGTON, D.C., 31 DECEMBER 2006

TECHNICAL MANUAL

OPERATOR'S MANUAL

FOR

CARRIER, PERSONNEL, FULL TRACKED, ARMORED M113A3
2350-01-219-7577 (EIC AEY)

CARRIER, COMMAND POST, LIGHT TRACKED M577A3
2350-01-369-6085 (EIC AE7)

CARRIER, SMOKE GENERATOR, FULL TRACKED M1059A3
2350-01-369-6083 (EIC AFA)

CARRIER, MORTAR, 120-MM M121, SELF-PROPELLED M1064A3
2350-01-369-6082 (EIC AE8)

CARRIER, STANDARDIZED INTEGRATED COMMAND POST SYSTEM (SICPS) M1068A3
2350-01-369-6086 (EIC AFC)

CARRIER, MECHANIZED SMOKE OBSCURANT M58
2350-01-418-6654 (EIC 5CG)

DISTRIBUTION STATEMENT A – Approved for public release; distribution is unlimited.

TM 9-2350-277-10, 2 January 2001 is updated as follows:

1. File this change sheet in front of the publication for reference purposes.
2. New or updated text is indicated by a vertical bar in the outer margin of the page.
3. Revised illustrations are indicated by a miniature pointing hand adjacent to the updated area.
4. Remove old pages/Work Packages and insert new pages/Work Packages as indicated below.

Remove Pages/Work Packages

a – g/h blank
A/B blank
i – ix/x blank
WP 0001 00 – 0002 00
Chapter 2 Index
WP 0004 00
WP 0021 00
WP 0023 00
WP 0025 00
WP 0035 01 – 0035 03
WP 0045 00
WP 0057 00
WP 0077 00
WP 0080 00 – 0081 00

Insert Pages/Work Packages

a – af
A/B blank
i – ix/x blank
WP 0001 00 – 0002 00
Chapter 2 Index
WP 0004 00
WP 0021 00
WP 0023 00
WP 0025 00
WP 0035 01 – 0035 03
WP 0045 00
WP 0057 00
WP 0077 00
WP 0080 00 – 0081 00

TM 9-2350-277-10

None
WP 0088 00 – 0089 00
Chapter 4 Index
WP 0090 00 – 0091 00
WP 0092 00 – 0093 01
None
WP 0101 00 – 0104 00
Index-1 – Index 11/12 blank
Metric Chart/Back Cover

WP 0086 01
WP 0088 00 – 0089 00
Chapter 4 Index
WP 0090 00 – 0091 00
WP 0092 00 – 0093 01
WP 0094 01
WP 0101 00 – 0104 00
Index-1 – Index 11/12 blank
Metric Chart/Back Cover

By Order of the Secretary of the Army:

Official:



JOYCE E. MORROW
*Administrative Assistant to the
Secretary of the Army*
0632402

PETER J. SCHOOMAKER
*General, United States Army
Chief of Staff*

DISTRIBUTION: To be distributed in accordance with the initial distribution requirements for IDN: 371204, requirements for TM 9-2350-277-10.

**TECHNICAL MANUAL
OPERATOR'S MANUAL
FOR**

**CARRIER, PERSONNEL, FULL TRACKED, ARMORED M113A3
2350-01-219-7577 (EIC AEY)**

**CARRIER, COMMAND POST, LIGHT TRACKED M577A3
2350-01-369-6085 (EIC AE7)**

**CARRIER, SMOKE GENERATOR, FULL TRACKED M1059A3
2350-01-369-6083 (EIC AFA)**

**CARRIER, MORTAR, 120-MM M121, SELF-PROPELLED M1064A3
2350-01-369-6082 (EIC AE8)**

**CARRIER, STANDARDIZED INTEGRATED COMMAND POST SYSTEM (SICPS) M1068A3
2350-01-369-6086 (EIC AFC)**

**CARRIER, MECHANIZED SMOKE OBSCURANT M58
2350-01-418-6654 (EIC 5CG)**

DISTRIBUTION STATEMENT A – Approved for public release; distribution is unlimited.

TM 9-2350-277-10, 2 January 2001 is updated as follows:

1. File this change sheet in front of the publication for reference purposes.
2. New or updated text is indicated by a vertical bar in the outer margin of the page.
3. Revised illustrations are indicated by a miniature pointing hand adjacent to the updated area.
4. Remove old pages/Work Packages and insert new pages/Work Packages as indicated below.

Remove Pages/Work Packages

e - f
A/B blank
iii - iv
WP 0002 00
WP 0004 00
WP 0023 00
WP 0028 00
WP 0034 00
WP 0035 00

Insert Pages/Work Packages

e - f
A/B blank
iii - iv
WP 0002 00
WP 0004 00
WP 0023 00
WP 0028 00
WP 0034 00
WP 0035 00

WP 0039 00
WP 0053 00
WP 0063 00
WP 0066 00
WP 0067 00
WP 0068 00
WP 0069 00
WP 0070 00
WP 0071 00
WP 0072 00
WP 0074 00
WP 0079 00
WP 0089 00
WP 0090 00
WP 0101 00
WP 0102 00
WP 0105 00
Index 1 – Index 8
Index 11/12 blank

WP 0039 00
None
None
None
None
None
None
None
None
None
WP 0074 00
WP 0079 00
WP 0089 00
WP 0090 00
WP 0101 00
WP 0102 00
WP 0105 00
Index 1 – Index 8
Index 11/12 blank

By Order of the Secretary of the Army:

Official:



JOEL B. HUDSON

*Administrative Assistant to the
Secretary of the Army*
0404104

PETER J. SCHOOMAKER
*General, United States Army
Chief of Staff*

DISTRIBUTION:

To be distributed in accordance with the initial distribution number (IDN) 371204 requirements for TM 9-2350-277-10.

CHANGE
NO. 2

HEADQUARTERS
DEPARTMENT OF THE ARMY
WASHINGTON, D.C., 02 October 2003

TECHNICAL MANUAL

OPERATOR' S MANUAL

FOR

**CARRIER, PERSONNEL, FULL TRACKED, ARMORED M113A3
2350-01-219-7577 (EIC AEY)**

**CARRIER, COMMAND POST, LIGHT TRACKED M577A3
2350-01-369-6085 (EIC AE7)**

**CARRIER, SMOKE GENERATOR, FULL TRACKED M1059A3
2350-01-369-6083 (EIC AFA)**

**CARRIER, MORTAR, 120-MM M121, SELF-PROPELLED M1064A3
2350-01-369-6082 (EIC AE8)**

**CARRIER, STANDARDIZED INTEGRATED COMMAND POST SYSTEM (SICPS) M1068A3
2350-01-369-6086 (EIC AFC)**

**CARRIER, MECHANIZED SMOKE OBSCURANT M58
2350-01-418-6654 (EIC 5CG)**

DISTRIBUTION STATEMENT A – Approved for public release; distribution is unlimited.

TM 9-2350-277-10, 2 January 2001 is updated as follows:

1. File this change sheet in front of the publication for reference purposes.
2. New or updated text is indicated by a vertical bar in the outer margin of the page.
3. Revised illustrations are indicated by a miniature pointing hand adjacent to the updated area.
4. Remove old pages/Work Packages and insert new pages/Work Packages as indicated below.

Remove Pages/Work Packages

Title
A/B
i-viii
WP 0001 00 – 0003 00
Chapter 2 WP Index
WP 0004 00
WP 0007 00
WP 0008 00
WP 0021 00
WP 0023 00 – 0024 00
WP 0028 00 – 0029 00
WP 0045 00
WP 0055 00
WP 0063 00
WP 0065 00 – 0068 00
WP 0072 00
WP 0074 00
WP 0076 00
WP 0078 00 – 0082 00
WP 0084 00 – 0085 00
WP 0088 00 – 0089 00
Chapter 4 WP Index
WP 0090 00 – 0091 00
None
WP 0092 00
None
WP 0093 00
None
WP 0094 00
WP 0095 00
WP 0101 00 – 0103 00
WP 0105 00 – 0106 00
Index
Cover

Insert Pages/Work Packages

Title
A/B
i-viii
WP 0001 00 – 0003 00
Chapter 2 WP Index
WP 0004 00
None
WP 0008 00
WP 0021 00
WP 0023 00 – 0024 00
WP 0028 00 – 0029 00
WP 0045 00
WP 0055 00
WP 0063 00
WP 0065 00 – 0068 00
WP 0072 00
WP 0074 00
WP 0076 00
WP 0078 00 – 0082 00
None
WP 0088 00 – 0089 00
Chapter 4 WP Index
WP 0090 00 – 0091 00
WP 0091 01
WP 0092 00
WP 0092 01
WP 0093 00
WP 0093 01
WP 0094 00
WP 0095 00
WP 0101 00 – 0103 00
WP 0105 00 – 0106 00
Index
Cover

By Order of the Secretary of the Army:

PETER J. SCHOOMAKER
*General, United States Army Official:
Chief of Staff*

Official:

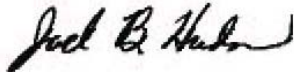

JOEL B. HUDSON
*Administrative Assistant to the
Secretary of the Army*
0133204

DISTRIBUTION:

To be distributed in accordance with the initial distribution number (IDN) 371204 requirements for TM 9-2350-277-10.

CHANGE
NO. 1

HEADQUARTERS
DEPARTMENT OF THE ARMY
WASHINGTON, D.C., 05 September 2003

TECHNICAL MANUAL

OPERATOR' S MANUAL

FOR

**CARRIER, PERSONNEL, FULL TRACKED, ARMORED M113A3
2350-01-219-7577 (EIC AEY)**

**CARRIER, COMMAND POST, LIGHT TRACKED M577A3
2350-01-369-6085 (EIC AE7)**

**CARRIER, ANTI-TANK (TOW), FULL TRACKED, ARMORED M901A3
2350-01-369-7253 (EIC AFD)**

**CARRIER, FIRE SUPPORT PERSONNEL, FULL TRACKED, ARMORED M981A3
2350-01-369-6079 (EIC AFB)**

**CARRIER, SMOKE GENERATOR, FULL TRACKED M1059A3
2350-01-369-6083 (EIC AFA)**

**CARRIER, MORTAR, 120-MM M121, SELF-PROPELLED M1064A3
2350-01-369-6082 (EIC AE8)**

**CARRIER, STANDARDIZED INTEGRATED COMMAND POST SYSTEM (SICPS) M1068A3
2350-01-369-6086 (EIC AFC)**

**CARRIER, MECHANIZED SMOKE OBSCURANT M58
2350-01-418-6654 (EIC 5CG)**

DISTRIBUTION STATEMENT A – Approved for public release; distribution is unlimited.

TM 9-2350-277-10, 2 January 2001 is updated as follows:

1. File this change sheet in front of the publication for reference purposes.
2. New or updated text is indicated by a vertical bar in the outer margin of the page.
3. Revised illustrations are indicated by a miniature pointing hand adjacent to the updated area.
4. Remove old pages/Work Packages and insert new pages/Work Packages as indicated below.

Remove Pages/Work Packages

a-g/h blank
A/B
i-ix/x blank
WP 0002 00
Chapter 2 WP Index
WP 0004 00
WP 0005 00
WP 0012 00
WP 0020 00
WP 0022 00
WP 0025 00
WP 0026 00
WP 0028 00
NEW
NEW
NEW
WP 0077 00
WP 0078 00
WP 0079 00
WP 0088 00
WP 0089 00
WP 0090 00
WP 0101 00
WP 0102 00
WP 0105 00

Insert Pages/Work Packages

a-g/h blank
A/B
i-ix/x blank
WP 0002 00
Chapter 2 WP Index
WP 0004 00
WP 0005 00
WP 0012 00
WP 0020 00
WP 0022 00
WP 0025 00
WP 0026 00
WP 0028 00
WP 0035 01
WP 0035 02
WP 0035 03
WP 0077 00
WP 0078 00
WP 0079 00
WP 0088 00
WP 0089 00
WP 0090 00
WP 0101 00
WP 0102 00
WP 0105 00

By Order of the Secretary of the Army:

Official:



JOEL B. HUDSON

*Administrative Assistant to the
Secretary of the Army*
0133204

PETER J. SCHOOMAKER
*General, United States Army
Chief of Staff*

DISTRIBUTION:

To be distributed in accordance with the initial distribution number (IDN) 371204 requirements for TM 9-2350-277-10.

INSERT LATEST UPDATED PAGES/WORK PACKAGES. DESTROY SUPERSEDED DATA.

LIST OF EFFECTIVE PAGES/WORK PACKAGES

Note: Updates to all portions of this TM are indicated by a vertical bar in the outer margin of the page.

Dates of issue for original and updated pages/work packages are:

- Original 0 -- 02 January 2001
- Change 1 -- 05 September 2003
- Change 2 -- 02 October 2003
- Change 3 -- 27 April 2004
- Change 4 -- 31 December 2006

TOTAL NUMBER OF PAGES FOR FRONT AND REAR MATTER IS 72 AND TOTAL NUMBER OF WORK PACKAGES IS 115 CONSISTING OF THE FOLLOWING:

Page/WP No.	*Change No.	Page/WP No.	*Change No.	Page/WP No.	*Change No.
Cover	2	WP 0054 00	0	WP 0106 00	2
a – af	4	WP 0055 00	2	WP 0107 00	0
Transmittal/Authentication	4	WP 0056 00	0	Index 1 – Index 11/12 blank	4
A/B blank	4	WP 0057 00	4	Authentication Page	0
i – ix/x blank	4	WP 0058 00 – 0062 00	0	DA 2028 Sample/Reverse	0
Chapter 1 WP Index	0	WP 0063 00 (Deleted)	3	DA 2028/Reverse (3)	0
WP 0001 00 – 0002 00	4	WP 0064 00	0	Metric Chart	0
WP 0003 00	2	WP 0065 00	2	Back Cover	4
Chapter 2 WP Index	4	WP 0066 00 – 0072 00 (Deleted)	3		
WP 0004 00	4	WP 0073 00	0		
WP 0005 00	1	WP 0074 00	3		
WP 0006 00	0	WP 0075 00	0		
WP 0007 00 (Deleted)	2	WP 0076 00	2		
WP 0008 00	2	WP 0077 00	4		
WP 0009 00 – 0011 00	0	WP 0078 00	2		
WP 0012 00	1	WP 0079 00	3		
WP 0013 00 – 0019 00	0	WP 0080 00 – 0081 00	4		
WP 0020 00	1	WP 0082 00	2		
WP 0021 00	4	WP 0083 00	0		
WP 0022 00	1	WP 0084 00 – 0085 00 (Deleted)	2		
WP 0023 00	4	WP 0086 00	0		
WP 0024 00	2	WP 0086 01 (Added)	4		
WP 0025 00	4	Chapter 3 WP Index	0		
WP 0026 00	1	WP 0087 00	0		
WP 0027 00	0	WP 0088 00 – 0089 00	4		
WP 0028 00	3	Chapter 4 WP Index	4		
WP 0029 00	2	WP 0090 00 – 0091 00	4		
WP 0030 00 – 0033 00	0	WP 0091 01 (Added)	2		
WP 0034 00 – 0035 00	3	WP 0092 00 – 0093 01	4		
WP 0035 01 – 0035 03	4	WP 0094 00	2		
WP 0036 00 – 0038 00	0	WP 0094 01 (Added)	4		
WP 0039 00	3	WP 0095 00	2		
WP 0040 00 – 0044 00	0	WP 0096 00 – 0100 00	0		
WP 0045 00	4	Chapter 5 WP Index	0		
WP 0046 00 – 0052 00	0	WP 0101 00 – 0104 00	4		
WP 0053 00 (Deleted)	3	WP 0105 00	3		

*Zero in this column indicates an original page

TECHNICAL MANUAL

OPERATOR'S MANUAL

CARRIER, PERSONNEL, FULL TRACKED, ARMORED M113A3
NSN 2350-01-219-7577
(EIC AEY)

CARRIER, COMMAND POST, LIGHT TRACKED M577A3
NSN 2350-01-369-6085
(EIC AE7)

CARRIER, SMOKE GENERATOR, FULL TRACKED M1059A3
NSN 2350-01-369-6083
(EIC AFA)

CARRIER, MORTAR, 120-MM M121, SELF-PROPELLED M1064A3
NSN 2350-01-369-6082
(EIC AE8)

CARRIER, STANDARDIZED INTEGRATED COMMAND POST SYSTEM (SICPS) M1068A3
NSN 2350-01-369-6086
(EIC AFC)

CARRIER, MECHANIZED SMOKE OBSCURANT M58
NSN 2350-01-418-6654
(EIC 5CG)

REPORTING ERRORS AND RECOMMENDING IMPROVEMENTS

You can help improve this publication. If you find any mistakes or if you know of a way to improve the procedures, please let us know. Submit your DA Form 2028 (Recommended Changes to Equipment Technical Publications), through the Internet, on the Army Electronic Product Support (AEPS) website. The Internet address is <http://aeprs.ria.army.mil>. The DA Form 2028 is located under the Public Applications section in the AEPS Public Home Page. Fill out the form and click on SUBMIT. Using this form on the AEPS will enable us to respond quicker to your comments and better manage the DA Form 2028 program. You may also mail, fax, or E-mail your letter or DA Form 2028 direct to: AMSTA-LC-LPIT/TECH PUBS, TACOM-RI, 1 Rock Island Arsenal, Rock Island, IL 61299-7630. The email address is TACOM-TECH-PUBS@ria.army.mil. The fax number is DSN 793-0726 or Commercial (309) 782-0726.

CURRENT AS OF 31 August 2005

SUPERSEDURE NOTICE — This manual supersedes TM 9-2350-277-10 dated 24 July 1994, including all changes.

DISTRIBUTION STATEMENT A — Approved for public release; distribution is unlimited.

TABLE OF CONTENTS

WP Sequence No.

WARNING SUMMARY

HOW TO USE THIS MANUAL

CHAPTER 1 — UNIT INTRODUCTORY INFORMATION WITH THEORY OF OPERATION

GENERAL INFORMATION.....	0001 00
EQUIPMENT DESCRIPTION.....	0002 00
THEORY OF OPERATION.....	0003 00

CHAPTER 2 — OPERATOR INSTRUCTIONS

DESCRIPTION AND USE OF OPERATOR'S CONTROLS AND INDICATORS.....	0004 00
OPEN/CLOSE RAMP ACCESS DOOR.....	0005 00
OPEN/CLOSE DRIVER'S HATCH COVER (M113A3, M1059A3, M1064A3, AND M58 ONLY).....	0006 00
DELETED.....	0007 00
OPEN/CLOSE CARGO HATCH COVER (M113A3 AND M1059A3 ONLY).....	0008 00
OPEN/CLOSE COMMANDER'S HATCH COVER (M113A3, M1059A3, M1064A3, AND M58 ONLY).....	0009 00
OPERATE COMMANDER'S CUPOLA (M113A3, M1059A3, M1064A3, AND M58 ONLY).....	0010 00
OPEN/CLOSE POWER PLANT ACCESS DOOR.....	0011 00
LOWER/RAISE RAMP.....	0012 00
ADJUST DRIVER'S SEAT.....	0013 00
ADJUST DRIVER'S LAP SEAT BELT AND SHOULDER HARNESS.....	0014 00
ADJUST COMMANDER'S SEAT (M113A3, M1059A3, M1064A3, AND M58 ONLY).....	0015 00
STOW/UNSTOW COMMANDER'S SEAT (M113A3, M1059A3, M1064A3, AND M58 ONLY).....	0016 00
STOW/UNSTOW JUMP SEAT (M113A3 AND M1059A3).....	0017 00
CONNECT CVC HELMET TO INTERCOM CONTROL BOX.....	0018 00
CONNECT CVC HELMET TO VEHICLE INTERCOMMUNICATIONS SYSTEM (VIS).....	0019 00
SET/RELEASE PARKING BRAKE.....	0020 00
START ENGINE.....	0021 00
START ENGINE WITH OUTSIDE POWER SOURCE.....	0022 00
DRIVE CARRIER.....	0023 00
STOP ENGINE.....	0024 00
FUEL CARRIER.....	0025 00
REFUEL CARRIER (M577A3 AND M1068A3 ONLY).....	0026 00
INSTALL/REMOVE WINDSHIELD.....	0027 00
OPERATE PERSONNEL HEATER.....	0028 00
OPERATE PERSONNEL COMPARTMENT VENTILATOR.....	0029 00

TABLE OF CONTENTS (cont)

	<u>WP Sequence No.</u>
OPERATE CARRIER LIGHTS.....	0030 00
OPERATE FIXED FIRE EXTINGUISHER SYSTEM.....	0031 00
OPERATE PORTABLE FIRE EXTINGUISHER.....	0032 00
INSTALL/REMOVE M17 PERISCOPES.....	0033 00
INSTALL/REMOVE AN/VVS-2(V)1A DRIVER'S NIGHT VISION (ALL EXCEPT M58).....	0034 00
OPERATE AN/VVS-2(V)1A DRIVER'S NIGHT VISION (ALL EXCEPT M58).....	0035 00
INSTALL/REMOVE AN/VAS-5 DRIVER'S VISION ENHANCER (DVE) (M58 ONLY).....	0035 01
OPERATE AN/VAS-5 DRIVER'S VISION ENHANCER (DVE) (M58 ONLY).....	0035 02
REPLACE DRIVER'S/COMMANDER'S DISPLAY (DVE) (M58 ONLY).....	0035 03
INSTALL/REMOVE MACHINE GUN (M2, .50 CAL) (M113A3, M1059A3, M1064A3, AND M58 ONLY).....	0036 00
SECURE MACHINE GUN (M2, .50 CAL) FOR TRAVEL (M113A3, M1059A3, M1064A3, AND M58 ONLY).....	0037 00
SECURE MACHINE GUN (M2, .50 CAL) TO ARMOR SHIELD FOR TRAVEL (M113A3, M1059A3, AND M1064A3 ONLY).....	0038 00
LOWER/STOW TRIM VANE.....	0039 00
REMOVE/INSTALL POWER PLANT ACCESS PANELS.....	0040 00
POSITIONING SPALL LINERS FOR ACCESS TO EQUIPMENT (M113A3 ONLY).....	0041 00
BLOCK/UNBLOCK CARRIER TRACKS.....	0042 00
INSTALL/REMOVE WATER/RATION HEATER.....	0043 00
OPERATE WATER/RATION HEATER.....	0044 00
OPERATE 5.0 KW AUXILIARY POWER UNIT (APU) (M577A3 AND M1068A3 ONLY).....	0045 00
OPEN/CLOSE COMMANDER'S HATCH (M577A3 AND M1068A3 ONLY).....	0046 00
OPERATE COMMANDER'S PLATFORM (M577A3 AND M1068A3 ONLY).....	0047 00
OPEN/CLOSE DRIVER'S HATCH (M577A3 AND M1068A3 ONLY).....	0048 00
RAISE/LOWER DROP LEAF TABLES (M577A3 ONLY).....	0049 00
INSTALL/REMOVE DRIVER'S BLACKOUT CURTAIN (M577A3 AND M1068A3 ONLY).....	0050 00
UNSTOW/STOW MAP TABLE AND BOARD (M577A3 AND M1068A3 ONLY).....	0051 00
OPEN/CLOSE MORTAR HATCH COVER (M1064A3 ONLY).....	0052 00
DELETED.....	0053 00
REMOVE/INSTALL 4.2 KW GENERATOR SET (M577A3 AND M1068A3 ONLY).....	0054 00
OPERATE 4.2 KW GENERATOR SET (M577A3 AND M1068A3 ONLY).....	0055 00
SET UP COMMAND POST TENT (COVERED EXTENSION) (M577A3 ONLY).....	0056 00
DISMANTLE/STOW MODULAR COMMAND POST SYSTEM (MCPS) (M1068A3 ONLY).....	0057 00
INSTALL/REMOVE TENT LINER FOR EXTREME COLD WEATHER (M577A3 ONLY).....	0058 00
DISMANTLE/STOW COMMAND POST TENT (COVERED EXTENSION) (M577A3 ONLY).....	0059 00

TABLE OF CONTENTS (cont)

WP Sequence No.

REFUEL GENERATOR SET (M577A3 AND M1068A3 ONLY).....	0060 00
OPERATE IN EXTREME COLD: BELOW -25° F (-31° C).....	0061 00
OPERATE ENGINE COOLANT HEATER (BELOW -25° F (-31° C)).....	0062 00
DELETED.....	0063 00
FORD WATER UP TO 40 INCHES DEEP.....	0064 00
PERFORM POST-FORDING OPERATIONS.....	0065 00
DELETED.....	0066 00
DELETED.....	0067 00
DELETED.....	0068 00
DELETED.....	0069 00
DELETED.....	0070 00
DELETED.....	0071 00
DELETED.....	0072 00
OPERATE CARRIER OVER ROUGH TERRAIN.....	0073 00
OPERATE CARRIER IN EXTREME HEAT, HUMIDITY, OR SALTY CONDITIONS.....	0074 00
BYPASS DEFECTIVE TRANSMISSION CONTROLLER.....	0075 00
SECURING INOPERABLE/UNSAFE RAMP.....	0076 00
TOWING DISABLED CARRIER.....	0077 00
TOW START DISABLED CARRIER.....	0078 00
TOWING TRAILER WITH CARRIER.....	0079 00
OPERATE NBC KIT.....	0080 00
OPERATE NBC SYSTEM.....	0081 00
OPERATE SMOKE GRENADE LAUNCHERS (ALL EXCEPT M577A3, M1064A3, AND M1068A3).....	0082 00
COVER/UNCOVER INTAKE AND EXHAUST GRILLES.....	0083 00
DELETED.....	0084 00
DELETED.....	0085 00
OPERATE GLOW PLUG COLD START SYSTEM (MANUAL OVERRIDE).....	0086 00
ASSEMBLY AND PREPARATION FOR USE MORTAR FIRE CONTROL SYSTEM (MFCS), M95.....	0086 01
 CHAPTER 3 — OPERATOR TROUBLESHOOTING PROCEDURES	
INTRODUCTION TROUBLESHOOTING.....	0087 00
TROUBLESHOOTING SYMPTOM INDEX.....	0088 00
TROUBLESHOOTING TABLE.....	0089 00
 CHAPTER 4 — MAINTENANCE INSTRUCTIONS FOR MAINTENANCE OF CARRIER	
PREVENTIVE MAINTENANCE CHECKS AND SERVICES.....	0090 00
ADJUST T130 TRACK TENSION.....	0091 00
ADJUST T150 TRACK TENSION.....	0091 01
BREAK/JOIN T130 TRACK.....	0092 00
BREAK/JOIN T150 TRACK.....	0092 01

TABLE OF CONTENTS (cont)

WP Sequence No.

REMOVE/INSTALL T130 TRACK SHOE.....	0093 00
REMOVE/INSTALL T150 TRACK SHOE.....	0093 01
TRACK SHOE WEAR LIMITS.....	0094 00
ASSEMBLE T130 TRACK SHOE SECTIONS OFF VEHICLE.....	0094 01
CHECK CARRIER BATTERIES.....	0095 00
SERVICE BILGE PUMPS.....	0096 00
CHECK/FILL COOLING SYSTEM.....	0097 00
MAINTENANCE OF AIR CLEANER.....	0098 00
CHECK/REPLACE MISSING PLUG (M113A3 ONLY).....	0099 00
SERVICE SMOKE GENERATOR FUEL CAN/FOG OIL TANK (M1059A3).....	0100 00
 CHAPTER 5 — OPERATOR SUPPORTING INFORMATION	
REFERENCES.....	0101 00
COMPONENTS OF END ITEM AND BASIC ISSUE ITEMS.....	0102 00
ADDITIONAL AUTHORIZATION LIST (AAL).....	0103 00
EXPENDABLE/DURABLE SUPPLIES AND MATERIALS LIST.....	0104 00
STOWAGE AND SIGN GUIDE.....	0105 00
STANDARD LOAD PLAN.....	0106 00
PLUG/SETSCREW GUIDE FOR ARMOR MOUNTING PROVISION HOLES.....	0107 00

HOW TO USE THIS MANUAL

HOW TO USE THIS MANUAL

This manual tells you to use the M113A3, M1059A3, M1064A3, M1068A3, M577A3, and M58 Armored Personnel Carriers. Before starting a task or procedure, read HOW TO USE THIS MANUAL and DESCRIPTION AND USE OF OPERATOR'S CONTROLS AND INDICATORS (WP 0004 00).

WHAT'S IN THE MANUAL — FRONT TO BACK

SUMMARY OF WARNINGS AND FIRST AID lists the Warnings and first aid information in this manual. The Warnings cover hazards that could kill or injure personnel. Shorter versions of these warnings may appear in the task procedures.

The TABLE OF CONTENTS lists the WPs in each chapter.

CHAPTER 1 covers General Information, Equipment Description, and Technical Principles of Operation. It briefly describes the major parts and features of the carrier.

CHAPTER 2 covers Descriptions and Use of Operator's Controls and Indicators, Operation under Usual Conditions Work Packages, Operation of Auxiliary Equipment Work Packages, and Operation under Unusual Conditions Work Packages.

CHAPTER 3 covers Troubleshooting Work Packages.

CHAPTER 4 covers Preventive Maintenance Checks and Services, including Lubrication Instructions and Maintenance Work Packages.

CHAPTER 5 provides supporting information for the TM. It includes the following WPs:

The REFERENCES WP (WP 0101 00) lists references to be used by personnel in operating and maintaining the carriers. These references include technical manuals and other publications.

The COEI/BII WP (WP 0102 00) lists Components of End Item and Basic Issue Items. Components of End Item are those items which are assembled and become a permanent part of the carrier. Basic Issue Items are items needed to put the carrier in operation, operate it, and do emergency repairs.

The AAL WP (WP 0103 00) lists additional items required to support the carrier during operation.

The EXPENDABLE/DURABLE SUPPLIES AND MATERIALS WP (WP 0104 00) lists expendable supplies and materials that will be needed to operate and maintain the carrier.

The STOWAGE AND SIGN GUIDE WP (WP 0105 00) is a stowage guide for all removable equipment carried in and on the carriers. This work package includes a guide to identification (ID) plates on the carriers.

The STANDARD LOAD PLAN WP (WP 0106 00) lists standard load plans for the M113A3 carrier.

The PLUG/SETSCREW GUIDE FOR ARMOR MOUNTING PROVISION HOLES WP (WP 0107 00) shows location of plugs and setscrews in armor mounting provisions holes on the M113A3 carrier only.

The INDEX is an alphabetical listing of all the major controls, procedures, indicators, systems, and subsystems covered in this manual. Each entry is cross-referenced to the WP number and page number.

DA FORM 2028 is used to report errors and to recommend improvements for procedures in this manual. Three blank DA Forms 2028 are in the back of this manual. A sample is provided to show you how to fill out the DA Form 2028.

The back cover includes a METRIC CONVERSION CHART that can be used to convert U.S. customary measurements to their metric equivalents. Measurements in this manual are given in U.S. customary unit with metric units in parentheses.

HOW TO USE THE WORK PACKAGES

How to find the WP you need

Pick a key word from the carrier part or system to be used. Look in the INDEX for this key word or the name of the action you will perform. Turn to the WP and page indicated.

The INDEX lists each WP under one or more headings. For example, the WP titled ADJUST DRIVER'S SEAT could be found under the two headings, "Driver," and "Seat."

HOW TO USE THIS MANUAL (cont)

How to read the WP

WPs provide either descriptive/supporting information or detailed procedures for operating and maintaining the equipment. The WPs in Chapter 1 include General Information only. Chapter 2 includes descriptive information on Controls and Indicators, and Operating Procedures. Chapter 3 includes Troubleshooting Procedures. Chapter 4 covers PMCS, including Lubrication Instructions and Maintenance Procedures. Chapter 5 includes Supporting Information.

Pay attention to all Warnings, Cautions, and Notes. These can appear in all types of procedures. They help you avoid harm to yourself, other personnel, and equipment. They also tell you things you should know about the procedure.

Before you start a procedure, get all the tools, supplies, and personnel you need to do the procedure. These items will be listed in the INITIAL SETUP of the WP.

Start with Step 1 and do each step in the order given. Numbered primary steps tell you WHAT to do. Alpha substeps tell you HOW to do it.

Look at the illustrations. Locators show you where the equipment and parts are located in the carrier. Close-up illustrations show the details you need to do the procedure.

Operator and Maintenance Instructions WPs

Operator Instructions WPs tell you how to operate the M113A3, M1059A3, M1064A3, M1068A3, M577A3, and M58 carriers and the equipment. Each operation WP gives you detailed steps which must be followed to complete the task.

Maintenance WPs tell you how to keep the carrier in operating condition. Crew members are authorized to remove, clean, inspect, lubricate, and install certain parts on the carrier.

Read the INITIAL SETUP section carefully before you start a task. Get the tools and supplies listed and the personnel needed to perform the task. Be sure that the equipment is in the condition called out under the Equipment Condition step.

Read all of the work package before starting. Follow the steps in the order. END OF TASK indicates the end of the procedure.

Preventive Maintenance Checks and Services (PMCS), Including Lubrication Instructions WP

Preventive Maintenance Checks and Services (PMCS) must be done to keep your carrier operating correctly. Do the PMCS procedures both daily and weekly as required. There are four types of PMCS:

The BEFORE (B) PMCS must be done before you operate the carrier.

The DURING (D) PMCS must be done when you operate the carrier. Monitor the carrier systems as you perform your mission. Perform DURING (D) PMCS on a system only when the system is required to complete your mission.

The AFTER (A) PMCS must be done after completing your mission.

The WEEKLY (W) PMCS must be done weekly.

The MONTHLY (M) PMCS must be done monthly.

The SEMI-ANNUALLY (S) PMCS must be done semi-annually.

Notify unit maintenance if anything seems wrong with the carrier or its systems and you cannot fix it yourself. Loose bolts or damaged welds are common things to watch for in every area. When checking hoses and fluid lines, look for wear, leaks, loose clamps, and loose fittings.

Troubleshooting WPs

Troubleshooting WPs help solve common problems and malfunctions. The Troubleshooting Symptom Index (WP 0088 00) lists malfunctions common to your carrier and the Index will guide you to the Troubleshooting Table.

DEFINITION OF WP TERMS

WARNINGS, CAUTIONS, and NOTES

Read all WARNINGS, CAUTIONS, and NOTES in the WP. WARNINGS, CAUTIONS, and NOTES are placed just before the step for which they apply. Ignoring a WARNING can cause death or injury to you or other personnel. Ignoring a CAUTION can cause damage to equipment. NOTES have facts to make the step and WP easier.

HOW TO USE THIS MANUAL (cont)

WARNINGS call attention to the things that could kill or injure personnel. WARNINGS are also listed at the front of the manual.

WARNING



Lowering ramp could injure personnel. Make sure no one is in ramp zone before you lower ramp. If tactical situation permits, sound horn before lowering ramp.

A sample WARNING is shown above.

CAUTIONS call attention to actions or material that could damage equipment.

CAUTION

Improper cable removal can cause a short circuit. Remove negative cable before you remove positive cable.

A sample CAUTION is shown above.

NOTES contain information that makes the step and WP easier to do.

NOTE

When quick release pin is removed, mirror control knob will spring back into locked position.

A sample NOTE is shown above.

Helper

Helpers are needed for WPs that require more than one person such as lifting heavy objects or acting as an observer.

If a helper is needed to perform a procedure, the INITIAL SETUP will list "Helper" under the PERSONNEL REQUIRED heading.

If helper assists with a step, the step will include: "Have helper assist."

If a helper performs the action alone, the step will start with "(H)."

Locational Terms

The terms FRONT, REAR, LEFT, and RIGHT are used to indicate where items are located on the carrier. Think of these locations as if you were standing on the ramp facing the inside of the carrier.

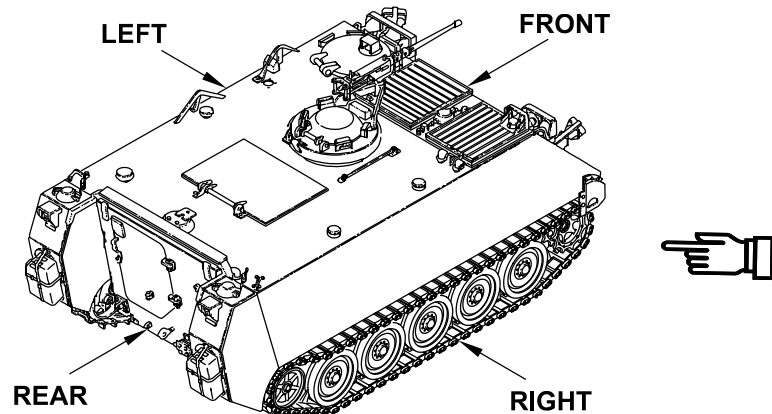

CHAPTER 1

UNIT INTRODUCTORY INFORMATION WITH THEORY OF OPERATION

WORK PACKAGE INDEX

<u>Title</u>	<u>Sequence No.</u>
GENERAL INFORMATION.....	.0001 00
EQUIPMENT DESCRIPTION.....	.0002 00
THEORY OF OPERATION.....	.0003 00

GENERAL INFORMATION

0001 00

SCOPE

This manual tells how to operate and maintain the following carriers:

M113A3 Full Tracked Armored Personnel Carrier
M577A3 Light Tracked Command Post Carrier
M1064A3 Self-propelled 120-mm Mortar Carrier
M1059A3 Full Tracked Smoke Generator Carrier
M1068A3 Standardized Integrated Command Post System
M58 Full Tracked Mechanized Smoke Obscurant Carrier

NOTE

For subordinate systems, see the following TMs:

M1064A3 120-mm Mortar — TM 9-1015-250-10.

M1059A3 Smoke System — TM 3-1040-283-10.

M1068A3 SICPS — TM 11-7010-256-12&P.

M58 Smoke System — TM 3-1040-285-10.

M1064A3 Mortar Fire Control System (MFCS) — TM 9-1220-248-10

M577A3 Mortar Fire Control System (MFCS) — TM 9-1220-249-10

MAINTENANCE FORMS, RECORDS, AND REPORTS

Department of the Army forms and procedures used for equipment maintenance will be those prescribed by DA Pamphlet 750-8, The Army Maintenance Management System (TAMMS) User's Manual.

REPORTING EQUIPMENT IMPROVEMENT RECOMMENDATIONS (EIR)

EIR can and must be submitted by anyone who is aware of an unsatisfactory condition with the equipment design or use. It is not necessary to show design or list a better way to perform a procedure, just simply tell why the design is unfavorable or why a procedure is difficult. EIR may be submitted on SF 368 (Quality Deficiency Report). Mail directly to Commander, U.S. Army Tank-automotive Command, Attn: AMSTA-TR-QCL, Warren, MI, 48397-5000.

CORROSION PREVENTION AND CONTROL (CPC)

Corrosion Prevention and Control (CPC) of Army materiel is a continuing concern. It is important that any corrosion problems with this item be reported so that the problem can be corrected and improvements can be made to prevent the problem in future items.

Corrosion specifically occurs with metals. It is an electrochemical process that causes the degradation of metals. It is commonly caused by exposure to moisture, acids, bases, or salts. An example is the rusting of iron. Corrosion damage in metals can be seen, depending on the metal, as tarnishing, pitting, fogging, surface residue, and/or cracking.

Plastics, composites, and rubbers can also degrade. Degradation is caused by thermal (heat), oxidation (oxygen), solvation (solvents), or photolytic (light, typically UV) processes. The most common exposures are excessive heat or light. Damage from these processes will appear as cracking, softening, swelling, and/or breaking.

SF Form 368, Product Quality Deficiency Report should be submitted to the address specified in DA PAM 750-8, The Army Maintenance Management System (TAMMS) User's Manual.

DESTRUCTION OF ARMY MATERIEL TO PREVENT ENEMY USE

See the following technical manuals for information on destruction of Army materiel:

TM 750-244-2 Procedures for Destruction of Electronics Materiel to Prevent Enemy Use.

TM 750-244-6 Procedures for Destruction of Tank Automotive Equipment to Prevent Enemy Use.

TM 750-244-7 Procedures for Destruction of Equipment in Federal Supply Classifications 1000, 1005, 1010, 1015, 1020, 1025, 1030, 1055, 1090, and 1095 to Prevent Enemy Use.

TM 43-0002-33 Procedures for Destruction of Conventional Ammunition and Improved Conventional Munitions (ICM) to Prevent Enemy Use.

PREPARATION FOR STORAGE OR SHIPMENT

For information about administrative storage or shipment, see the following documents:

Specification	Applicable Carriers
MIL-DTL-45360	M113A3, M1059A3, and M1064A3
ATPD 2227	M577A3 and M1068A3

NOMENCLATURE CROSS-REFERENCE

This listing includes nomenclature cross-references used in this manual.

CVC Helmet	DH-132 Helmet
Dipstick	Liquid Measure Gauge Rod
M42 Mask	Mask, Chemical-Biological: Tank, M42
Track and Sprocket	Track Tension, Track Bushing and Sprocket
Gauge	Wear Gauge
Transmission	Transmission, Cross Drive
Slave Cable	Adapter Cable Assembly
Vehicle Power Cable	Cable, Vehicle, W2

LIST OF ABBREVIATIONS / ACRONYMS

Many abbreviations are used in this manual. They are listed below. Learn what each one means. It will make your job easier.

A	After
APU	Auxiliary Power Unit
B	Before
BATT	Battery
BO	Blackout
BRT	Bright
CB	Circuit Breaker or Common Battery
CI	Commander's Interface
COEIL	Components of End Item List
CVC	Combat Vehicle Communications
CCW	Counterclockwise
CW	Clockwise
D	During
DAGR	Defense Advanced GPS Receiver
DD	Driver's Display
DVE	Driver's Vision Enhancer
ENG	Engine
FDC	Fire Direction Center

FOR	Field of Regard
FOV	Family of Vehicles
GD	Gunner's Display
GEN	Generator
HI-TEMP	High Temperature
INTERCOM	Intercommunication
IR	Infrared
KW	Kilowatt
LO	Lubrication Order
MCPS	Modular Command Post System
MFCS	Mortar Fire Control System
NBC	Nuclear, Biological and Chemical
N2	Nitrogen Gas
OVE	On Vehicle Equipment
PD	Pointing Device
PLGR	Precision Lightweight GPS Receiver
PMCS	Preventive Maintenance Checks and Services
PRESS	Pressure
SICPS	Standardized Integrated Command Post System
TEMP	Temperature
TRANS	Transmission
Vent	Ventilation
VIS	Vehicle Intercommunication System
W	Weekly

SAFETY, CARE, AND HANDLING

Hearing Protection. You must use earplugs and other approved hearing protectors while you are inside the carrier. The CVC helmet does not have enough hearing protection. Make sure you know how to use the ear plugs and hearing protectors that are issued to you. Keep them clean and ready to use. Read warning in Warning Summary (page a).

EQUIPMENT DESCRIPTION

0002 00**CARRIERS**

The carriers covered in this manual are built for tough cross-country travel and high speed driving on good roads. All carriers can ford water up to 40 inches (102 cm) deep. All carriers can be transported by cargo aircraft. All carriers except the M577A3 and M1068A3 can be parachute-dropped to troops in the field.

LOCATIONAL TERMS

The terms right, left, front, or rear are used in this manual to describe areas and parts of the carriers and their locations relative to each other. The terms are used the same way you would use them if you stood at the ramp end of the carrier and looked forward.

PECULIAR COMPONENTS

Components peculiar to a specific carrier are indicated within each title or illustration throughout this manual. All components and systems not indicated in this manner are common to all carriers.

M113A3 CARRIER — RIGHT REAR VIEW

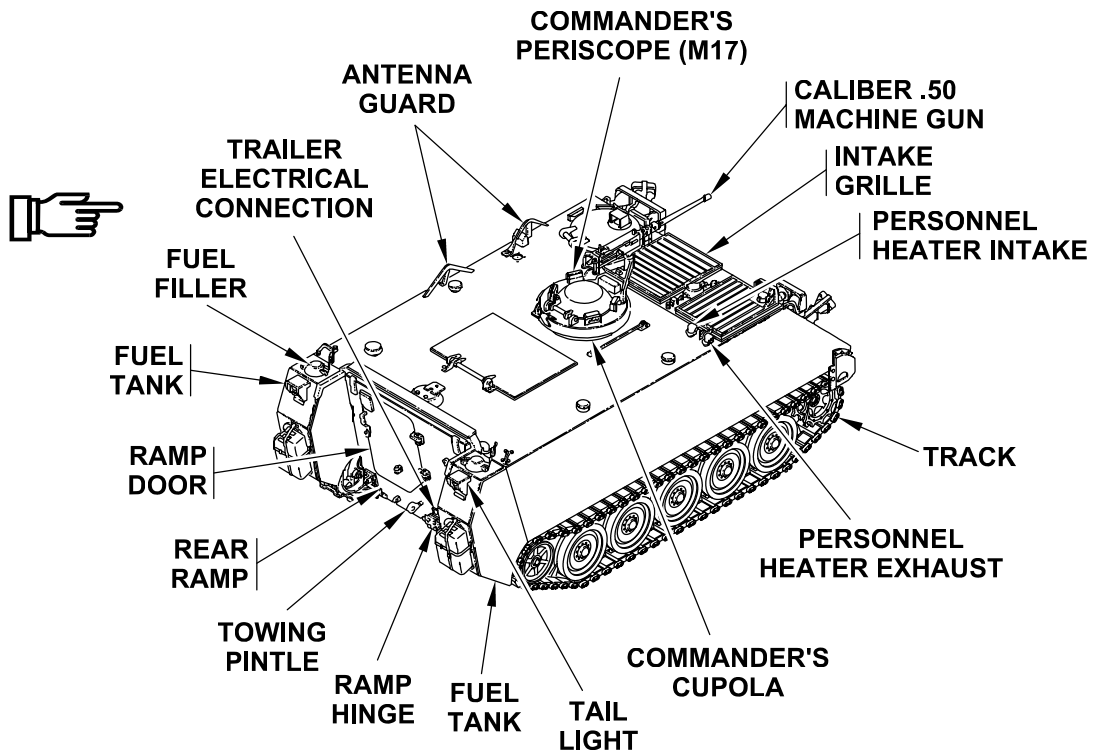

M113A3 CARRIER — REAR VIEW

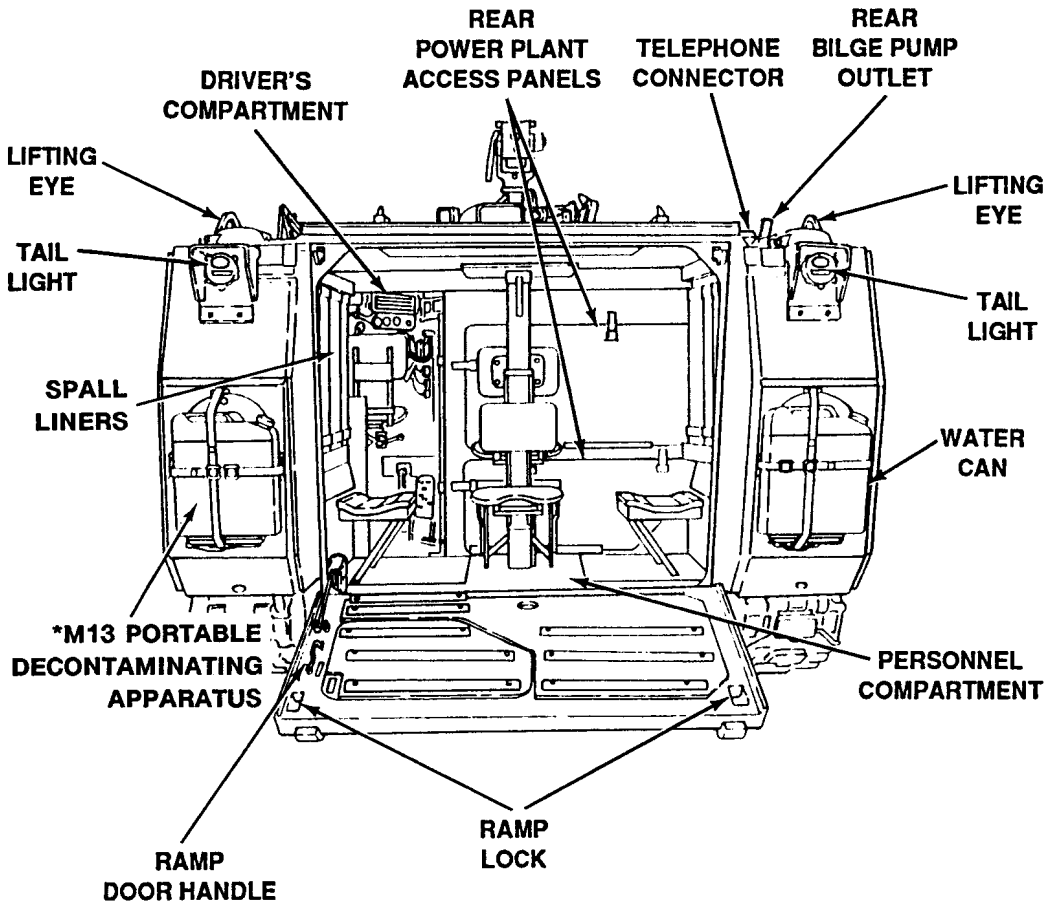

M113A3 PERSONNEL CARRIER (FOV) — INTERIOR VIEW

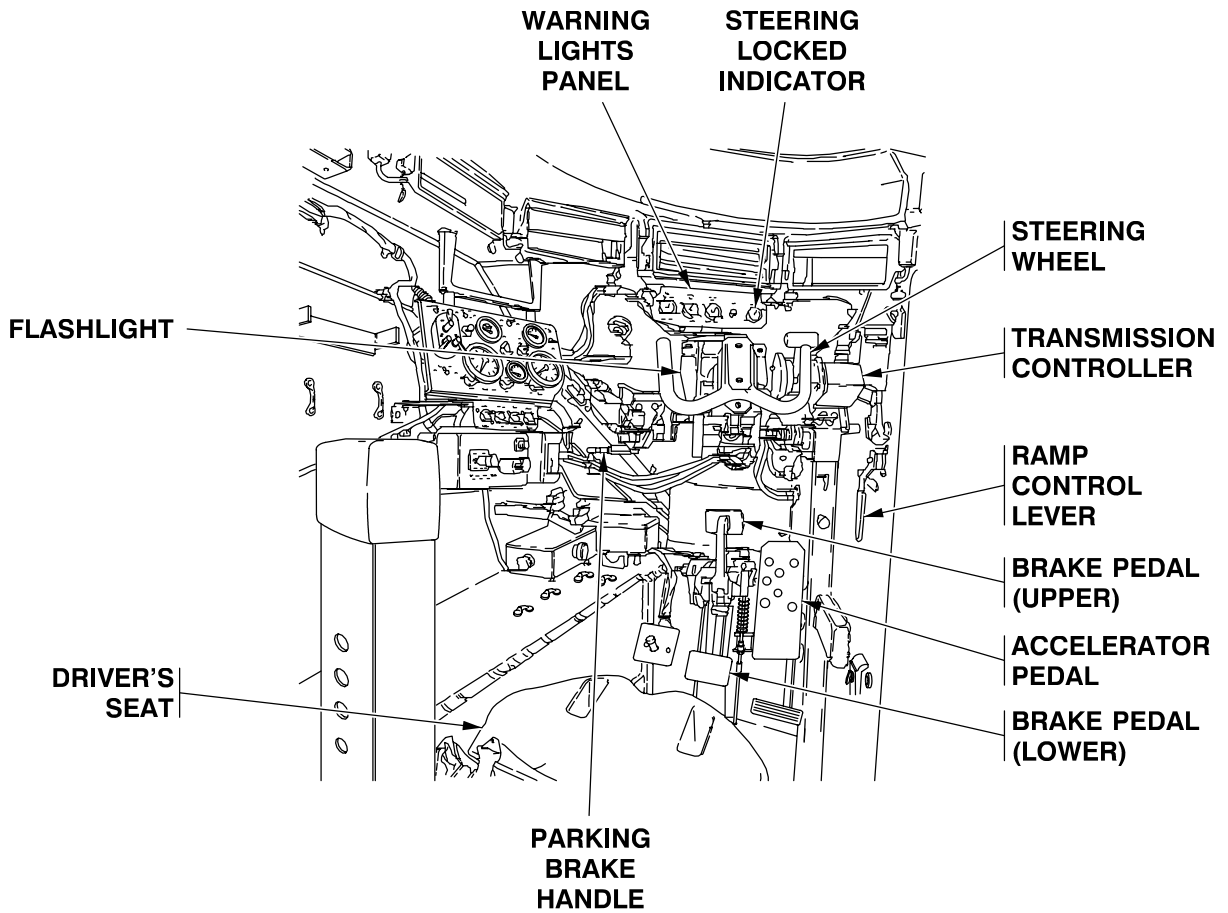

M113A3 CARRIER — PERSONNEL COMPARTMENT VIEW

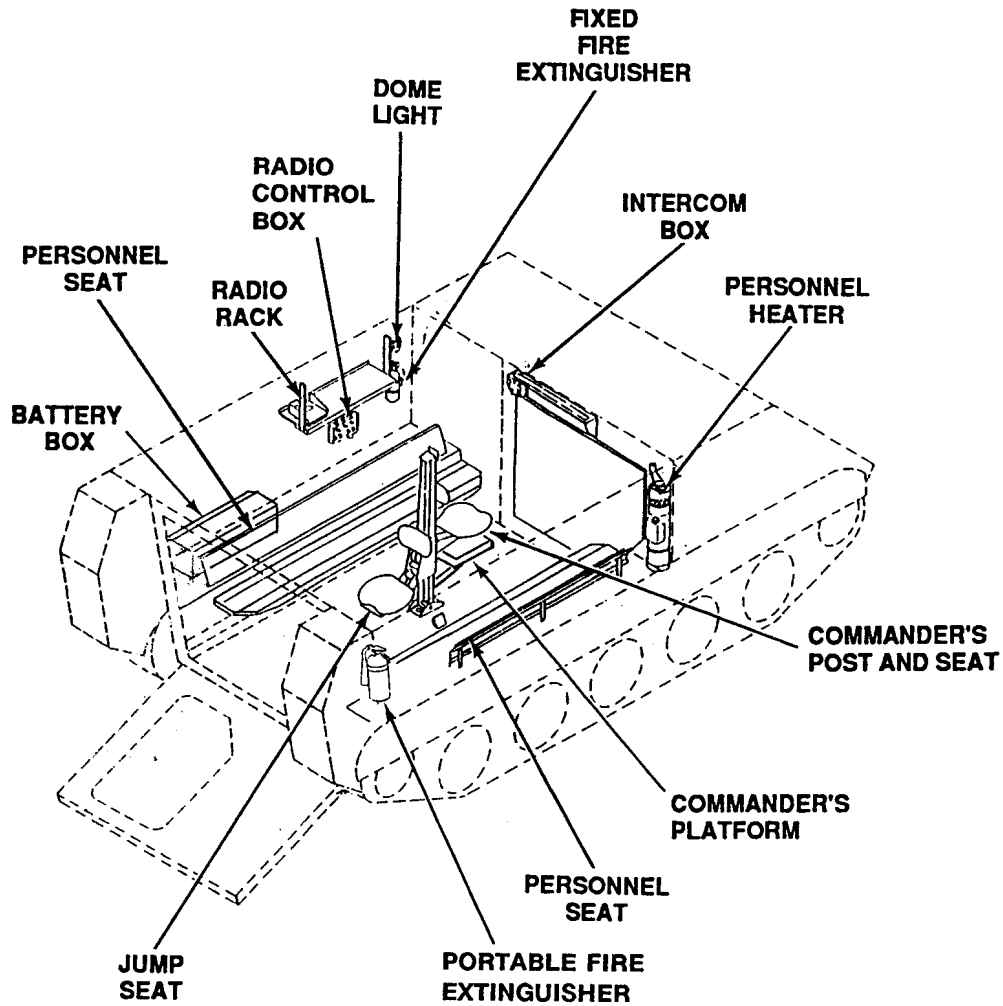

M577A3 COMMAND POST CARRIER

This carrier is designed as a command post and staff office. It has a crew of five, including the driver. The M577A3's capabilities and features are:

- It travels easily over rough terrain.
- It fords water up to 40 inches (102 cm) deep.
- It can move at high speeds on improved roads and highways.
- It is air transportable, but not air droppable.
- It provides protection for field commanders in a tactical environment.
- It has a 5.0 KW auxiliary power unit for communication and lighting power. (The 4.2 KW generator set will be used until the 5.0 KW APU is available.)
- It has a tent stowed on the rear top plate to extend the work area.
- It is propelled and steered on land and in water by tracks.
- It has M17 periscopes around the driver's hatch for vision when buttoned up.
- It has an M19A1 periscope stowed near the driver. The periscope can be installed in driver's hatch to provide night vision under blackout conditions.
- It can be equipped to carry an NBC (gas particulate filter) unit, driver's windshield kit, an engine coolant heater kit, and personnel heater kit (for cold weather operation).
- It can be equipped to carry a Mortar Fire Control System (MFCS).
- It can be equipped to carry a water/ration heater.

Maintenance and operating procedures for the 5.0 KW Auxiliary Power Unit are in TM 9-6115-664-13&P.

M577A3 COMMAND POST CARRIER — LEFT FRONT VIEW

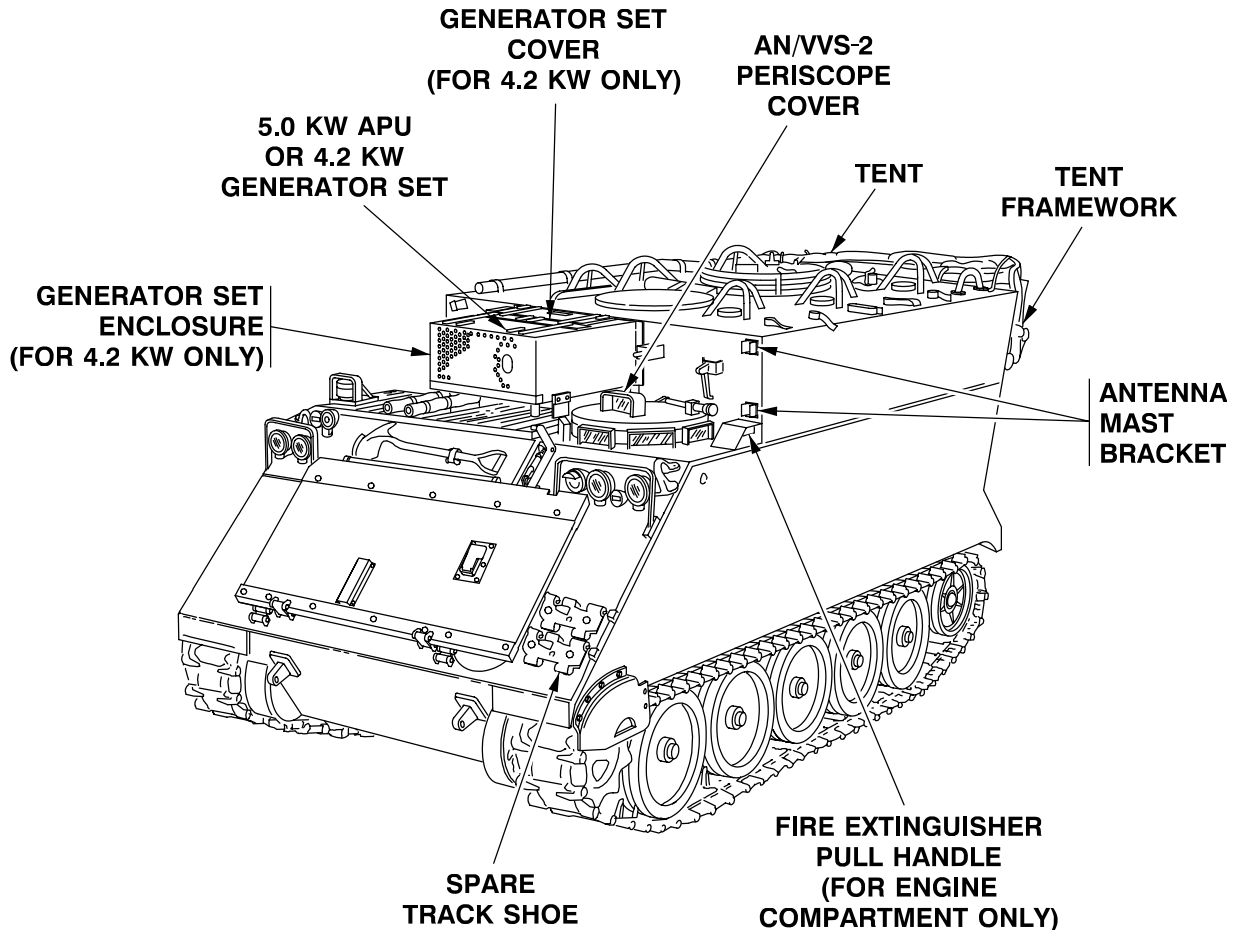

M577A3 COMMAND POST CARRIER — RIGHT REAR VIEW

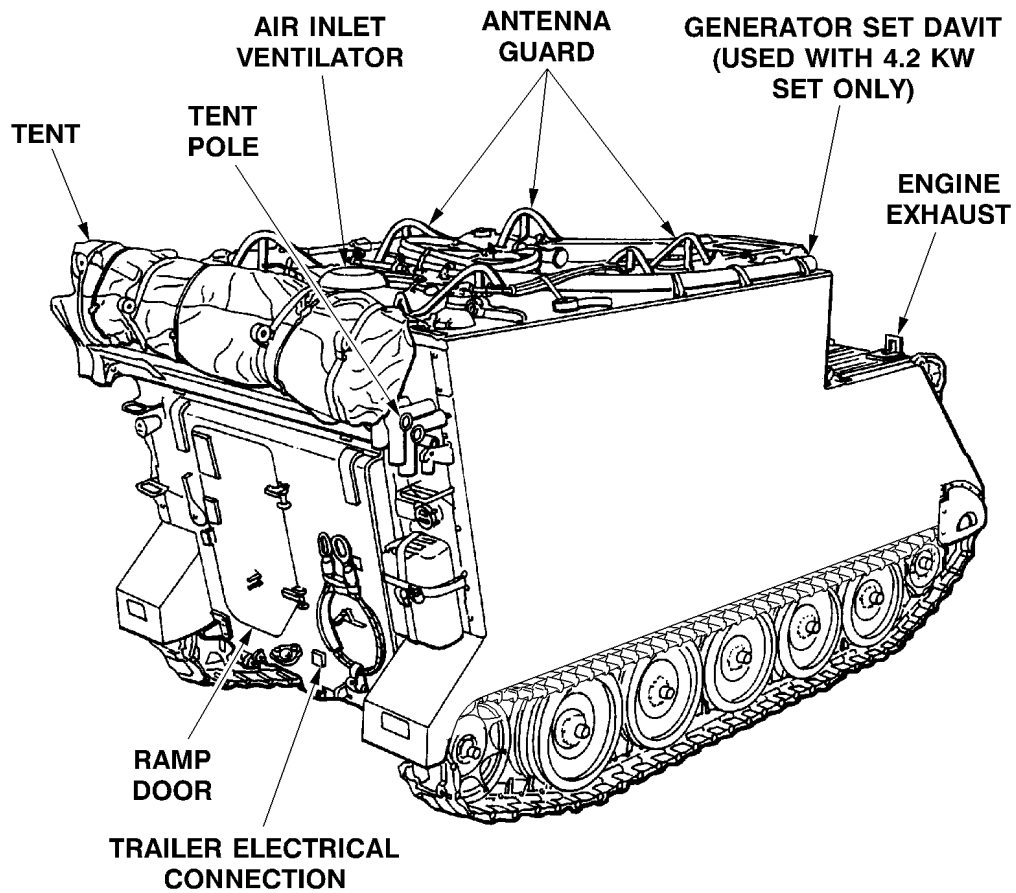

M577A3 COMMAND POST CARRIER — REAR VIEW

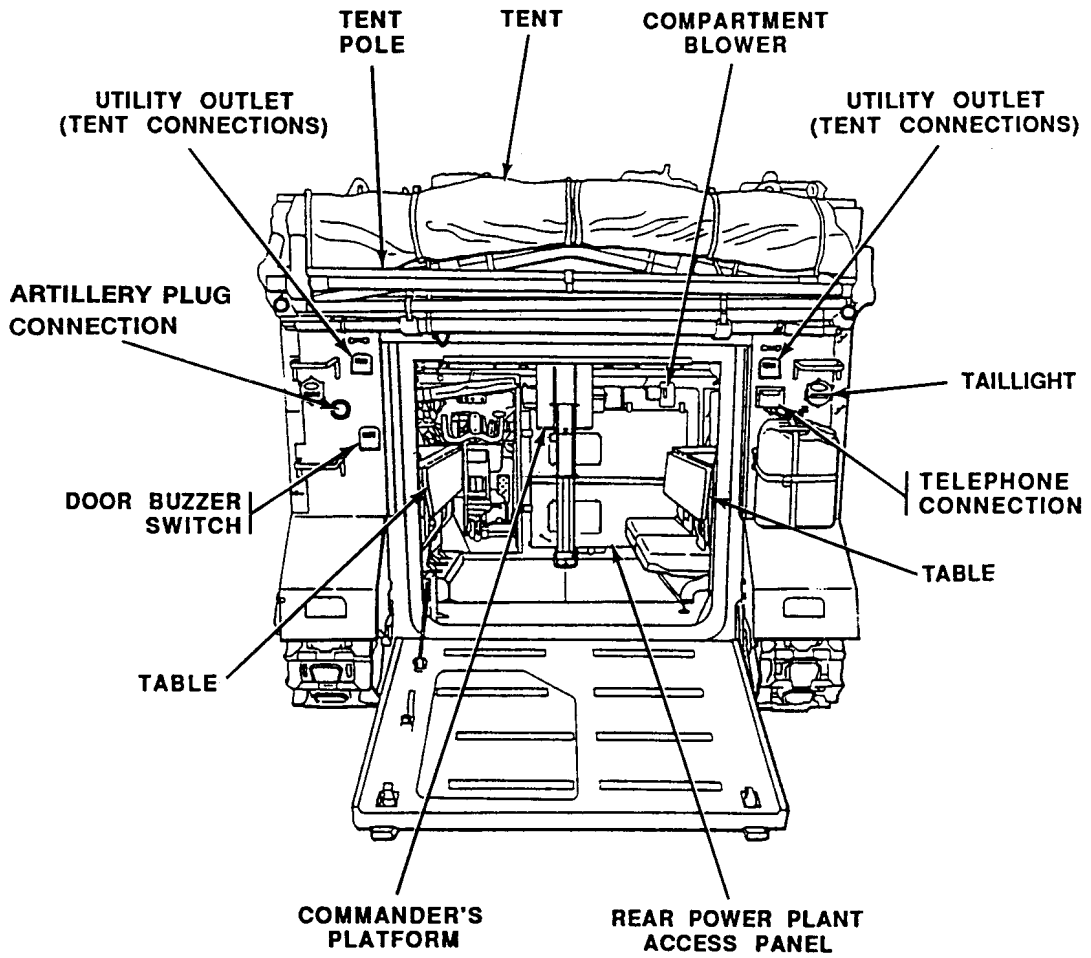

M577A3 COMMAND POST CARRIER — REAR COMPARTMENT

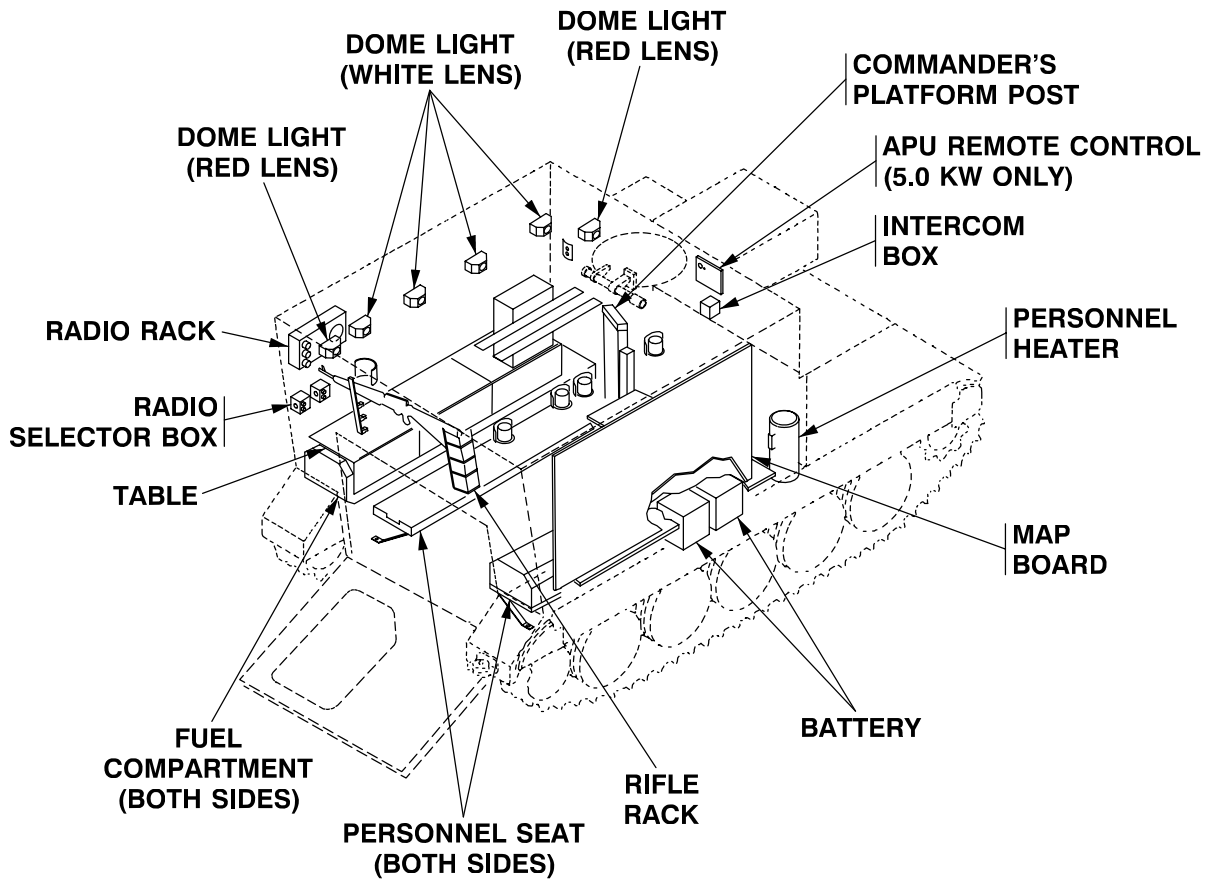

M1068A3 STANDARDIZED INTEGRATED COMMAND POST SYSTEM

This carrier is designed as a command post and staff office. It has a crew of four, including the driver. The M1068A3's capabilities and features are:

It travels easily over rough terrain.

It fords water up to 40 inches (102 cm) deep.

It can move at high speeds on improved roads and highways.

It is air transportable, but not parachute droppable.

It provides protection for field commanders in a tactical environment.

It has a 5.0 KW auxiliary power unit set for communication, lighting power, and charging carrier batteries.

It has a tent stowed on the left side top plate to extend the work area. A table, map board, and fluorescent lights are part of the modular command post system.

It is propelled and steered on land and in water by tracks.

It has M17 periscopes around the driver's hatch for vision when buttoned up.

It has an AN/VVS-2 driver's night vision periscope stowed near the driver. The periscope can be installed in driver's hatch to provide night vision under blackout conditions.

It can be equipped to carry an NBC (gas particulate filter) unit, driver's windshield kit, an engine coolant heater kit, and personnel heater kit (for cold weather operation).

It has a power enclosure panel to provide AC & DC power to outlets around the interior of the carrier.

It has an external communications entry box.

It has an external power entry box which provides the ability to receive or supply AC power and also contains a grounding lug for the surface wire grounding kit.

It has two internal fluorescent work lights.

See TM 11-7010-256-12&P Operator's Manual on Communication Hardware/Common Hardware and Software (CHS).

Operating procedures for the Modular Command Post System are in TM 10-8340-243-13&P.

Maintenance and operating procedures for the 5.0 KW Auxiliary Power Unit are in TM 9-6115-664-13&P.

M1068A3 STANDARDIZED INTEGRATED COMMAND POST SYSTEM — LEFT FRONT VIEW

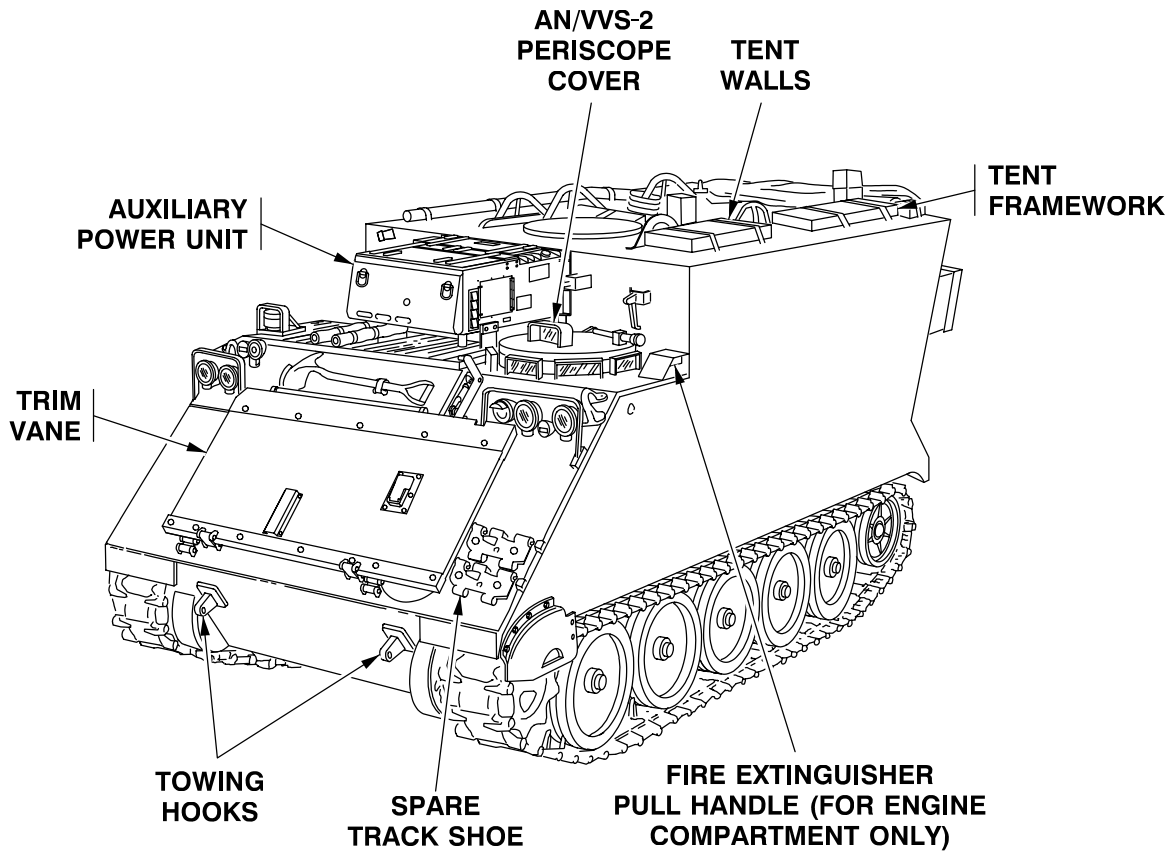

M1068A3 STANDARDIZED INTEGRATED COMMAND POST SYSTEM — RIGHT REAR VIEW

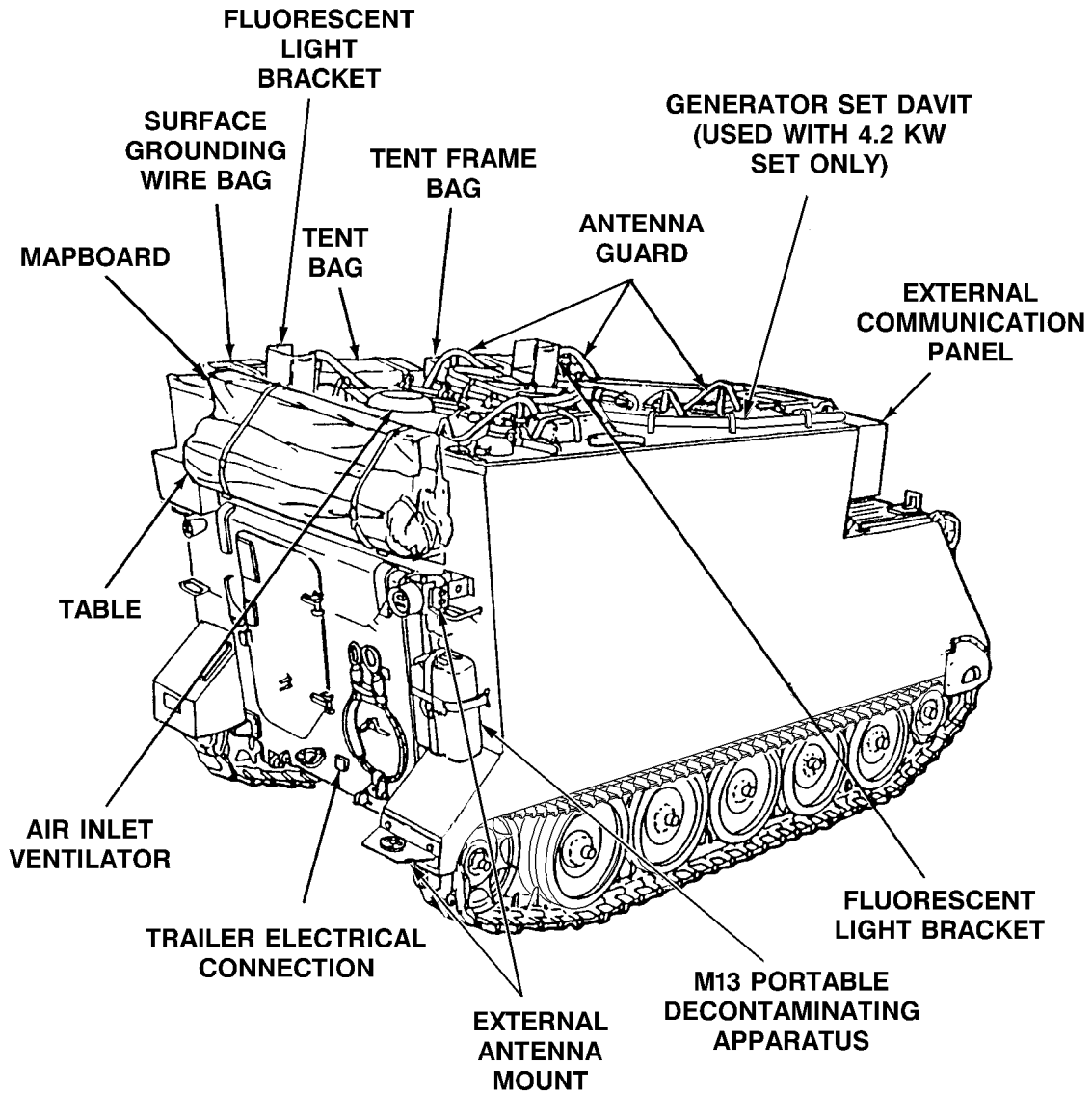

M1068A3 STANDARDIZED INTEGRATED COMMAND POST SYSTEM — REAR VIEW

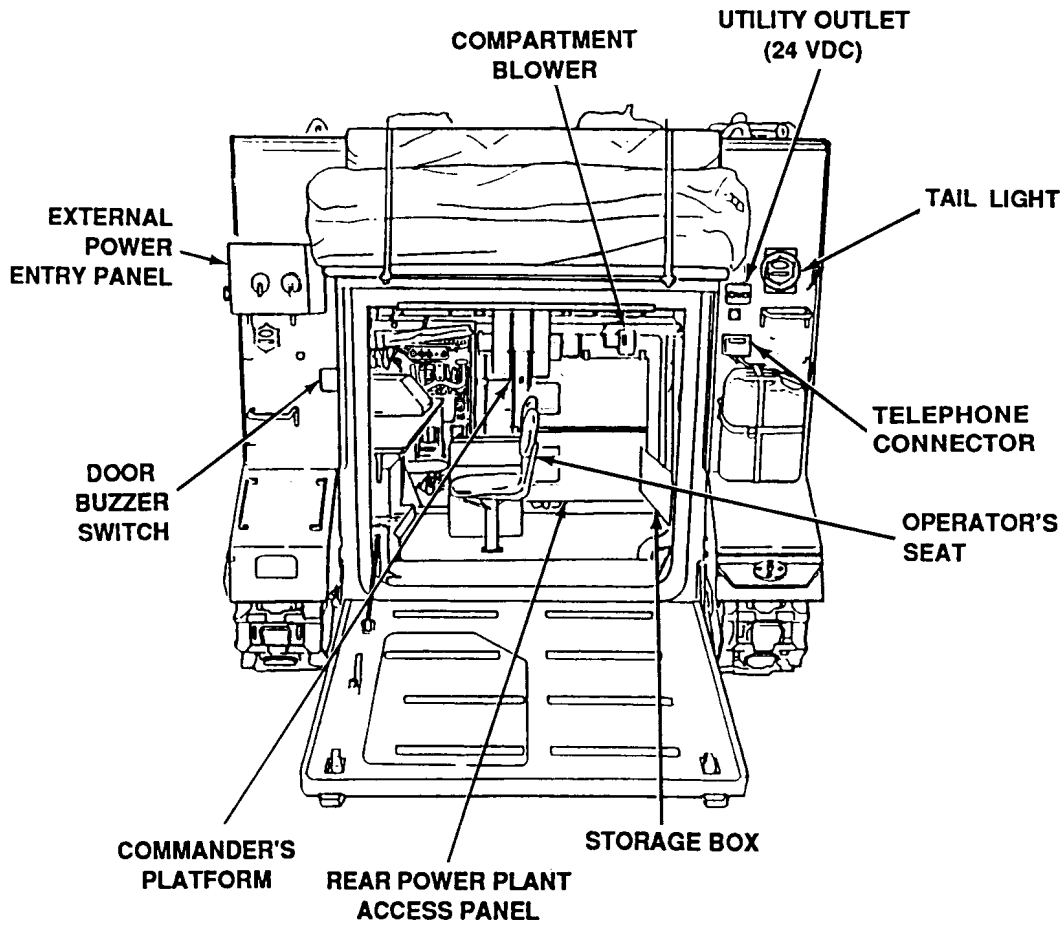

M1068A3 STANDARDIZED INTEGRATED COMMAND POST SYSTEM — REAR COMPARTMENT (LEFT SIDE)

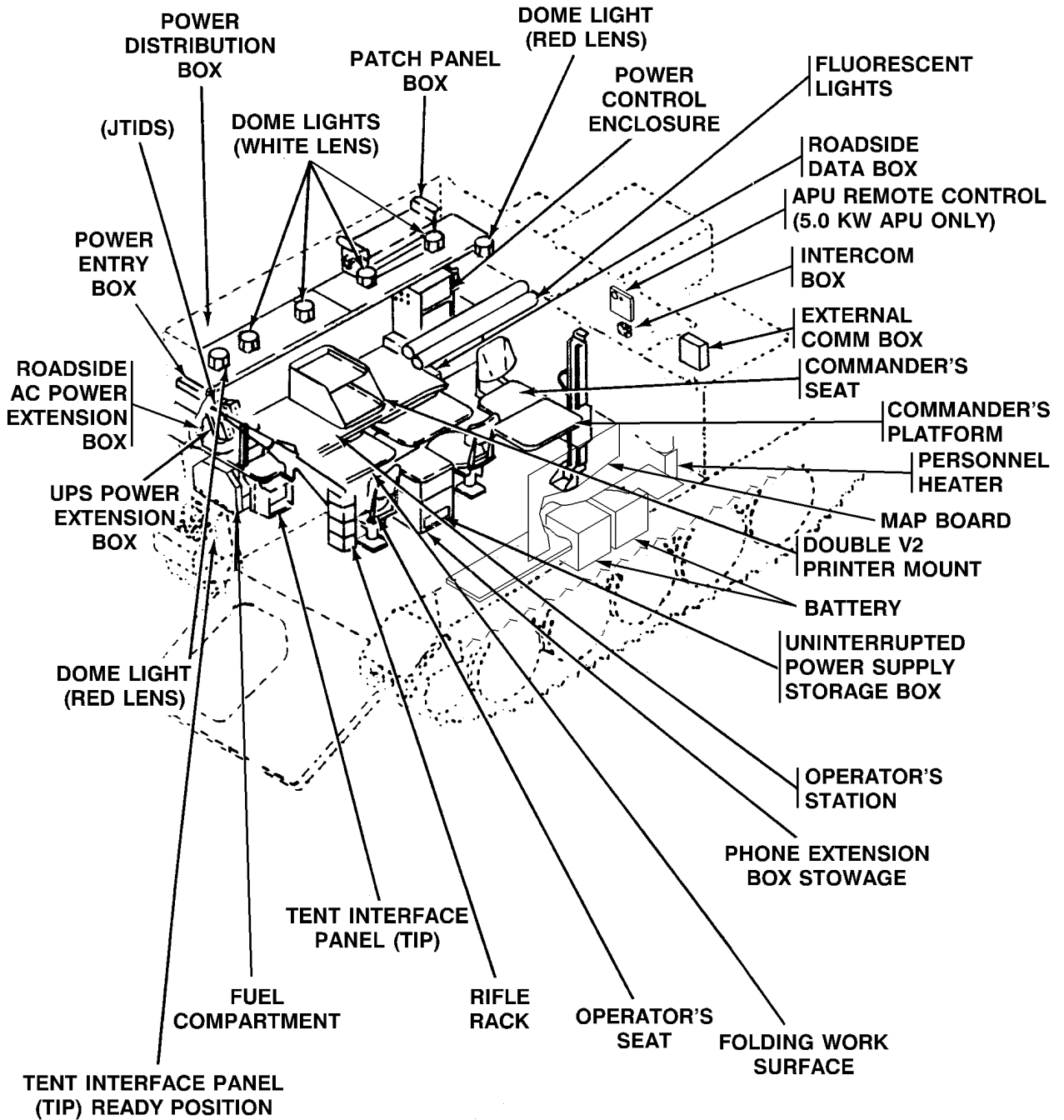

M1068A3 STANDARDIZED INTEGRATED COMMAND POST SYSTEM — REAR COMPARTMENT (RIGHT SIDE)

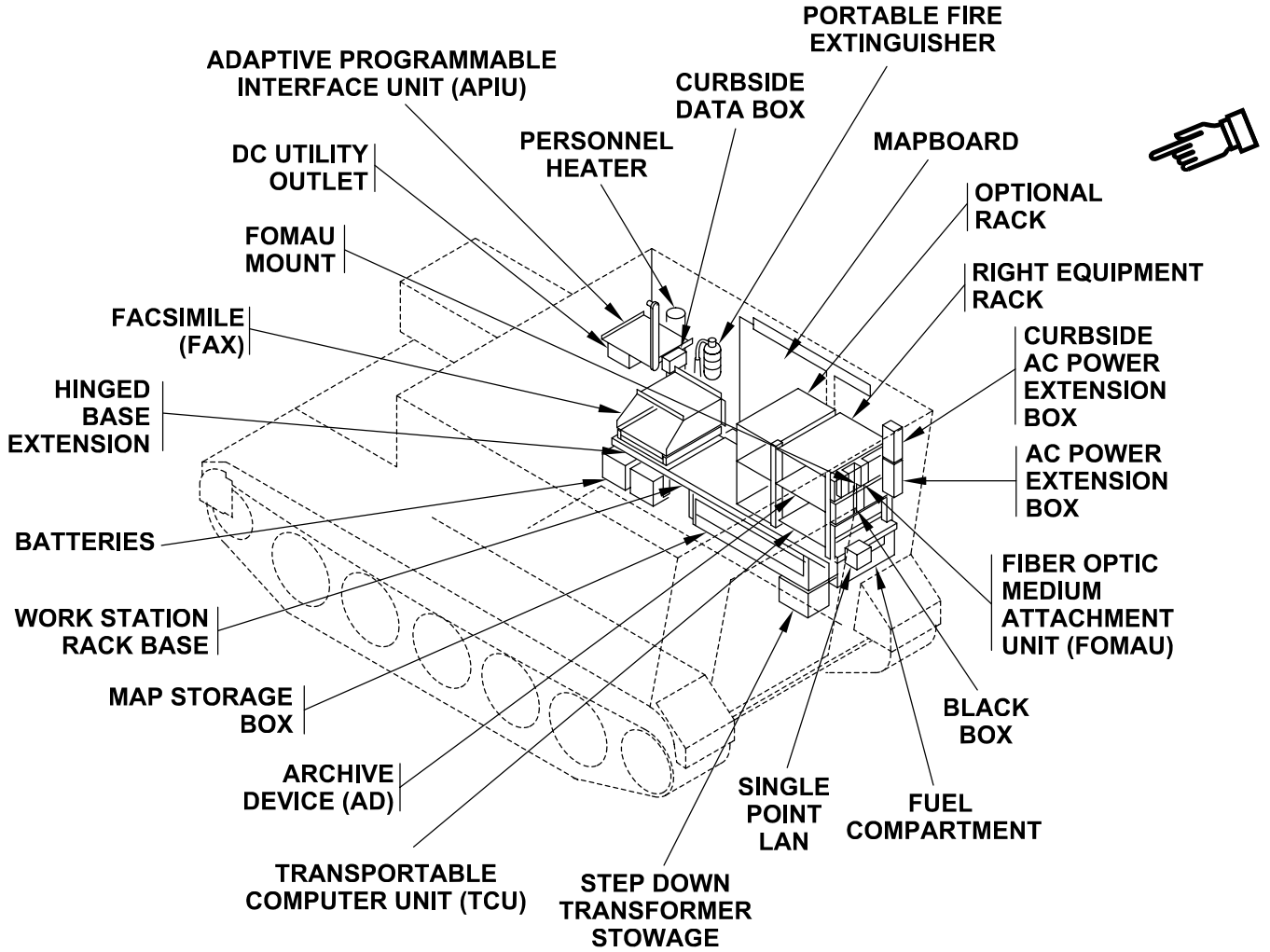

M1068A3 STANDARDIZED INTEGRATED COMMAND POST SYSTEM — UTILITY OUTLET

The utility outlet located on the right side is used to operate 24-volt accessories.

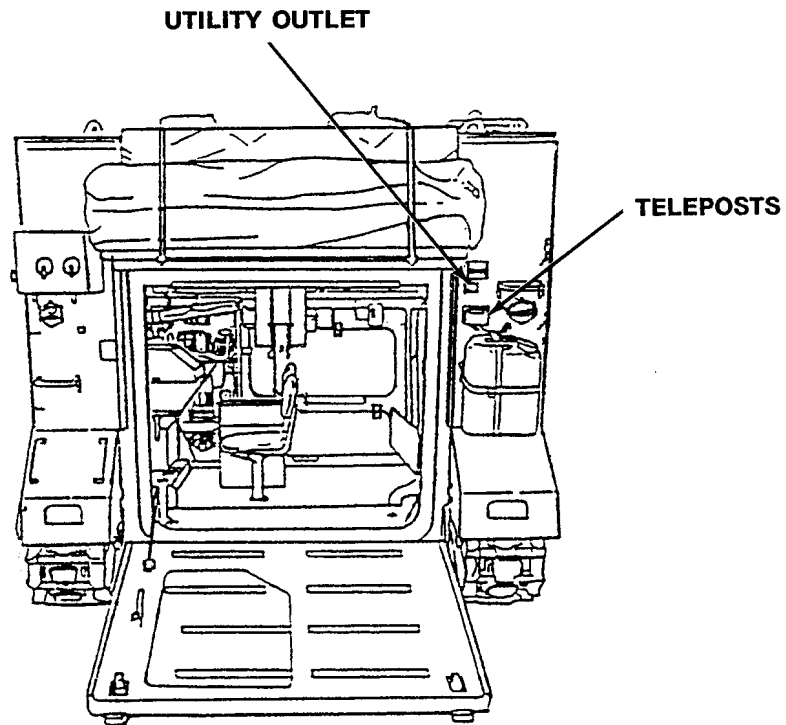

M1064A3 MORTAR CARRIER

This carrier is designed to carry the 4.7 inch (120-mm) Mortar M121. The mortar can be fired from a turntable in the carrier, or removed and fired from a ground baseplate. The carrier has a crew of four, including the driver. The M1064A3's capabilities and features are:

- It travels easily over rough terrain.
- It fords water up to 40 inches (102 cm) deep.
- It can move at high speeds on improved roads and highways.
- It is air transportable and can be dropped by parachute to troops in the field.
- It has an enlarged three-piece firing hatch. This permits mortar to be fired through an arc of 90 degrees over the rear of the carrier.
- It has a cupola with a caliber .50 machine gun.
- It is propelled and steered on land and in water by tracks.
- It has M17 periscopes around the driver's and commander's hatches for vision when buttoned up.
- It has an AN/VVS-2 driver's night vision periscope stowed near the driver. The periscope can be installed in the driver's hatch to provide night vision under blackout conditions.
- It can be equipped to carry an NBC (gas particulate filter) unit, a driver's windshield kit, an engine coolant heater kit, and personnel heater kit (for cold weather operation) and Mortar Fire Control System (MFCS).

The operation of the 4.7-inch (120-mm) Mortar M121 used on the M1064A3 Carrier is covered in TM 9-1015-250-10.

M1064A3 MORTAR CARRIER — LEFT FRONT VIEW

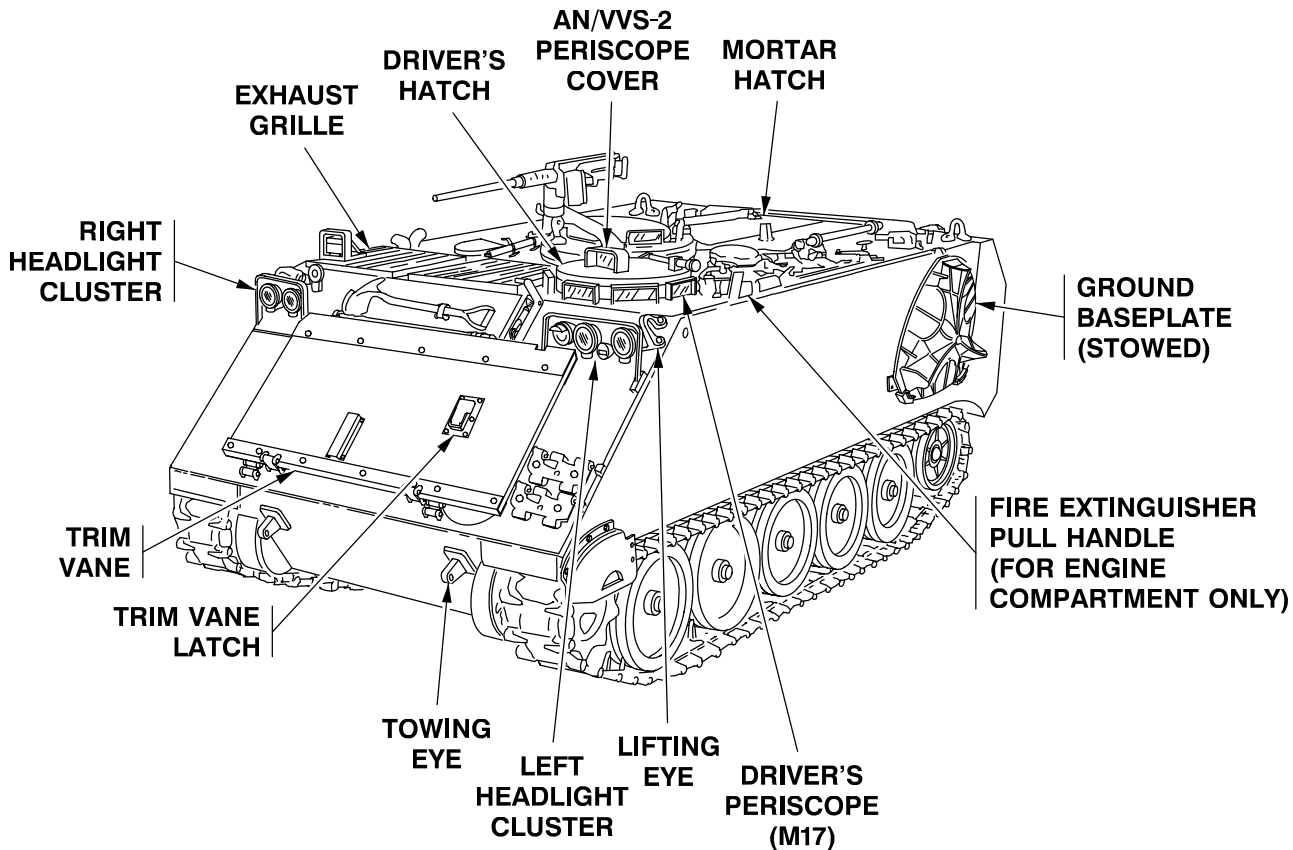

M1064A3 MORTAR CARRIER — RIGHT REAR VIEW

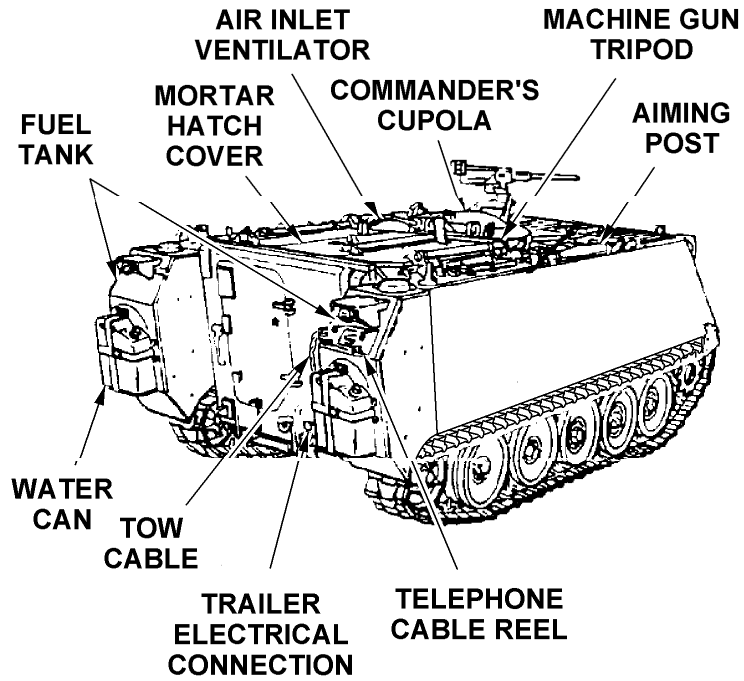

M1064A3 MORTAR CARRIER — REAR VIEW

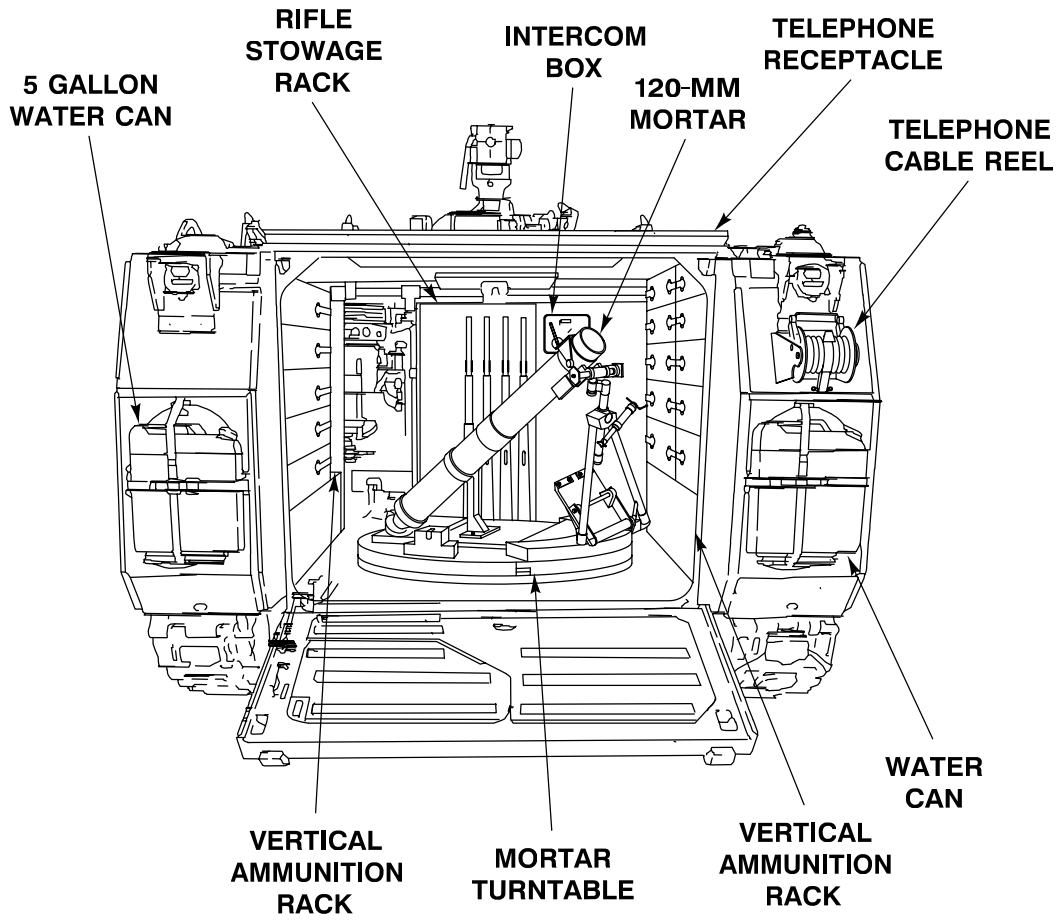

M1064A3 MORTAR CARRIER — REAR COMPARTMENT

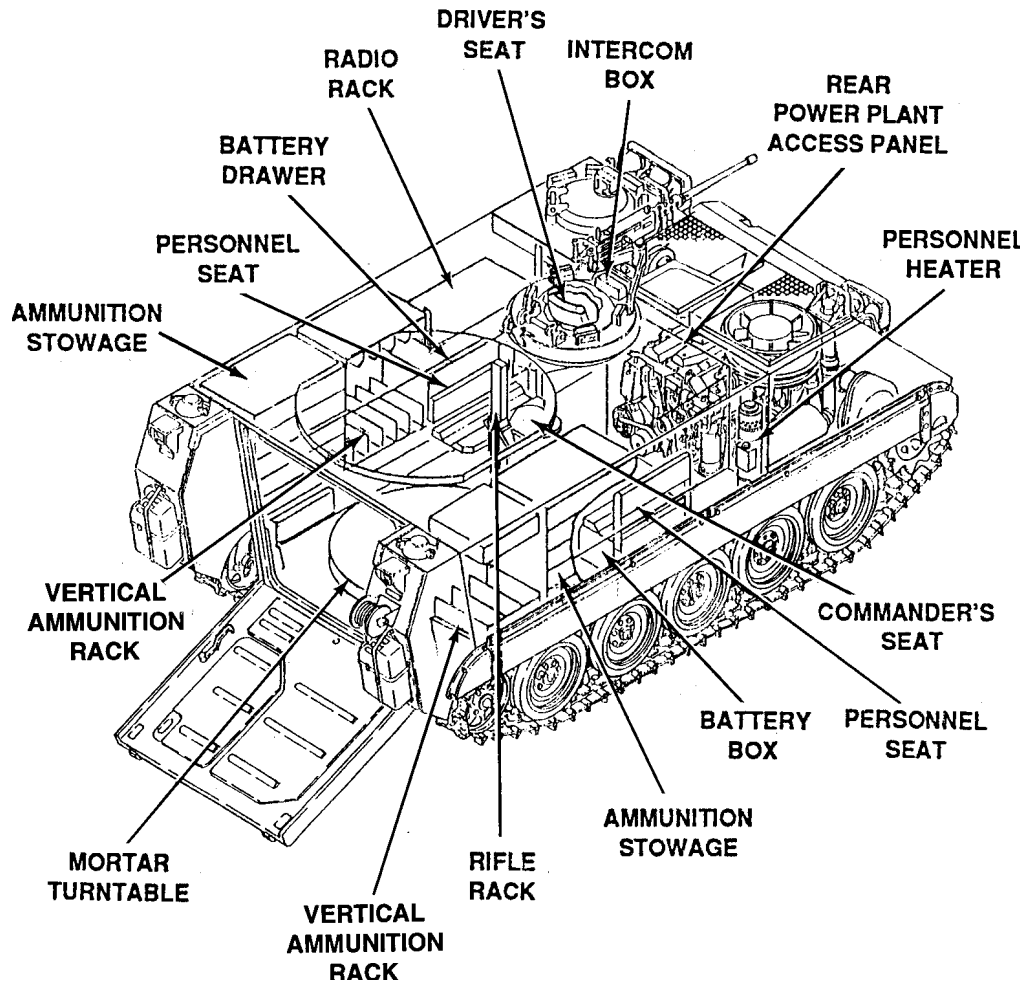

M1059A3 FULL TRACKED SMOKE GENERATOR CARRIER

This carrier is designed to generate a smoke screen in the battlefield environment. The M1059A3 carries a crew of three. A caliber .50 machine gun is mounted on a cupola on top of the carrier. The M1059A3's capabilities and features are:

- It travels easily over rough terrain.
- It fords water up to 40 inches (102 cm) deep.
- It can move at high speeds on improved roads and highways.
- It is air transportable and can be dropped by parachute to troops in the field.
- It is propelled and steered on land and in water by tracks.
- It has M17 periscopes around the driver's and commander's hatches for vision when buttoned up.
- It has an AN/VVS-2 driver's night vision periscope stowed near the driver. The periscope can be installed in the driver's hatch to provide night vision under blackout conditions.
- It is equipped with smoke grenade launchers.
- It is equipped to carry an NBC (gas particulate filter) unit, a driver's windshield kit, an engine coolant heater kit, and personnel heater kit (for cold weather operation).
- It is equipped with the M157 smoke generator system with enough fuel and fog oil for 1 hour of continuous operation.
- It can be equipped to carry a marine set kit and a capstan kit.

The M1059A3 is built from the same plans as the M113A3 except the M1059A3 has the M157A2 smoke generator system mounted. The M157A2 is a remote controlled unit which uses a pulse jet engine and fog oil to produce smoke. The system consists of six major assemblies: two M54A1E1 smoke generator assemblies, a control panel assembly, a fog oil pump/tank assembly, an air compressor assembly, and two 5-gallon fuel cans with special plugs.

M1059A3 FULL TRACKED SMOKE GENERATOR CARRIER — LEFT FRONT VIEW

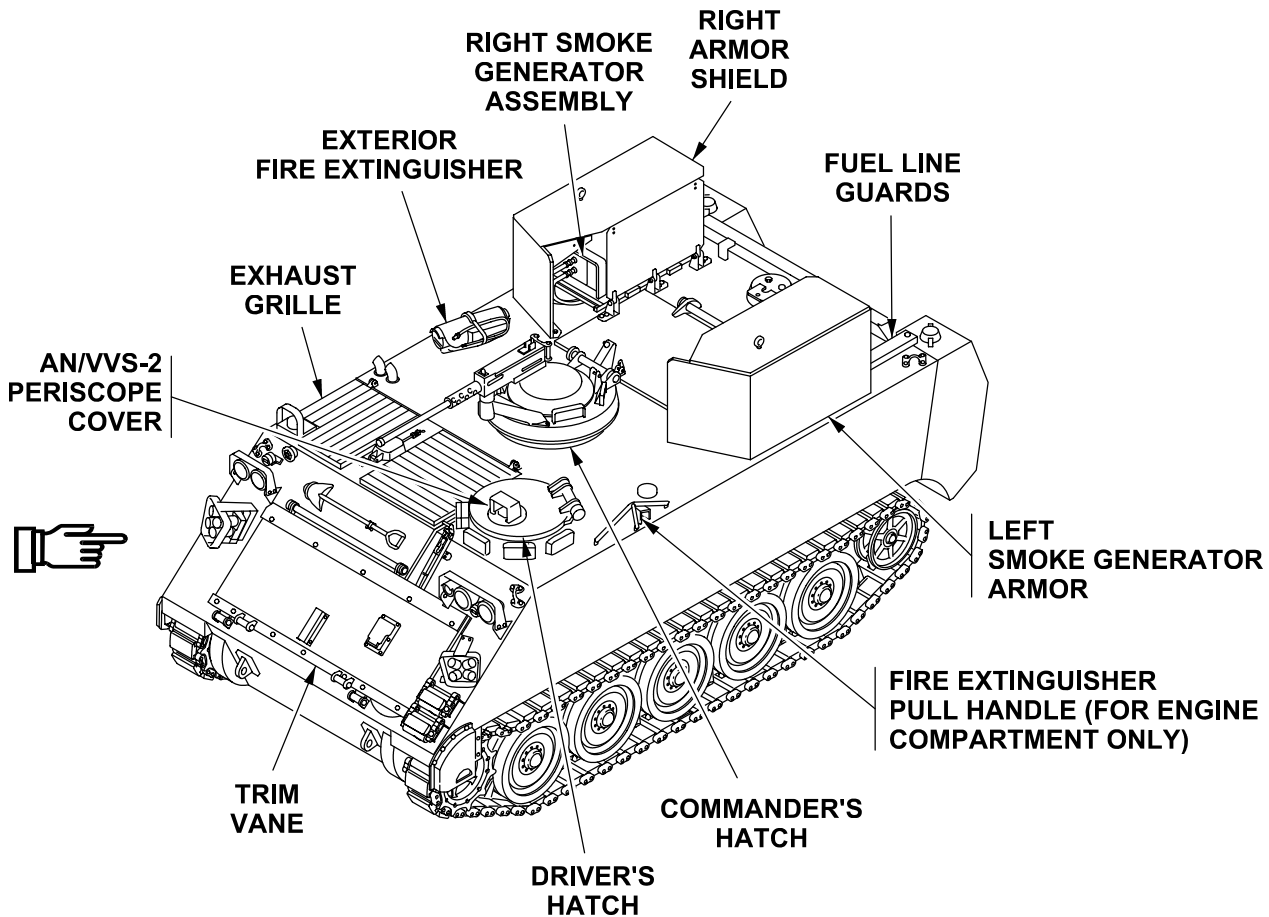

M1059A3 FULL TRACKED SMOKE GENERATOR CARRIER — RIGHT REAR VIEW

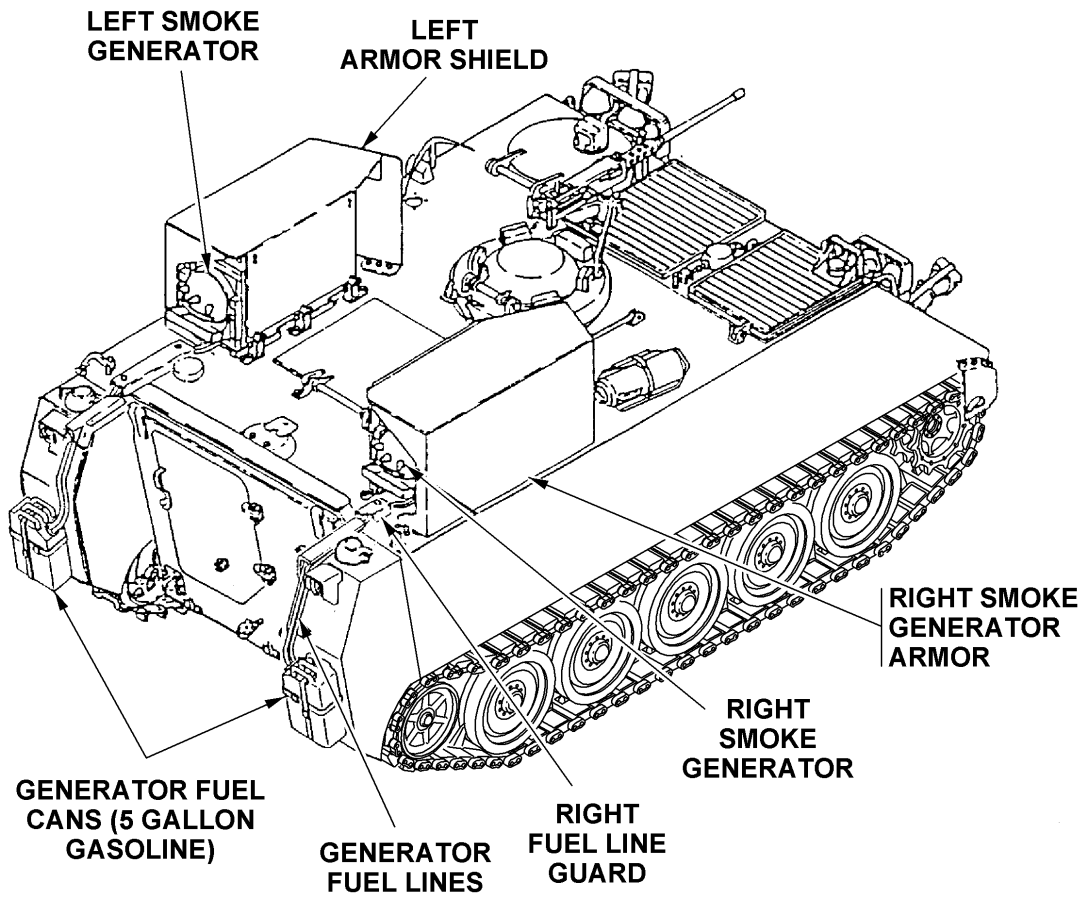

M1059A3 FULL TRACKED SMOKE GENERATOR CARRIER — INTERIOR ARRANGEMENT

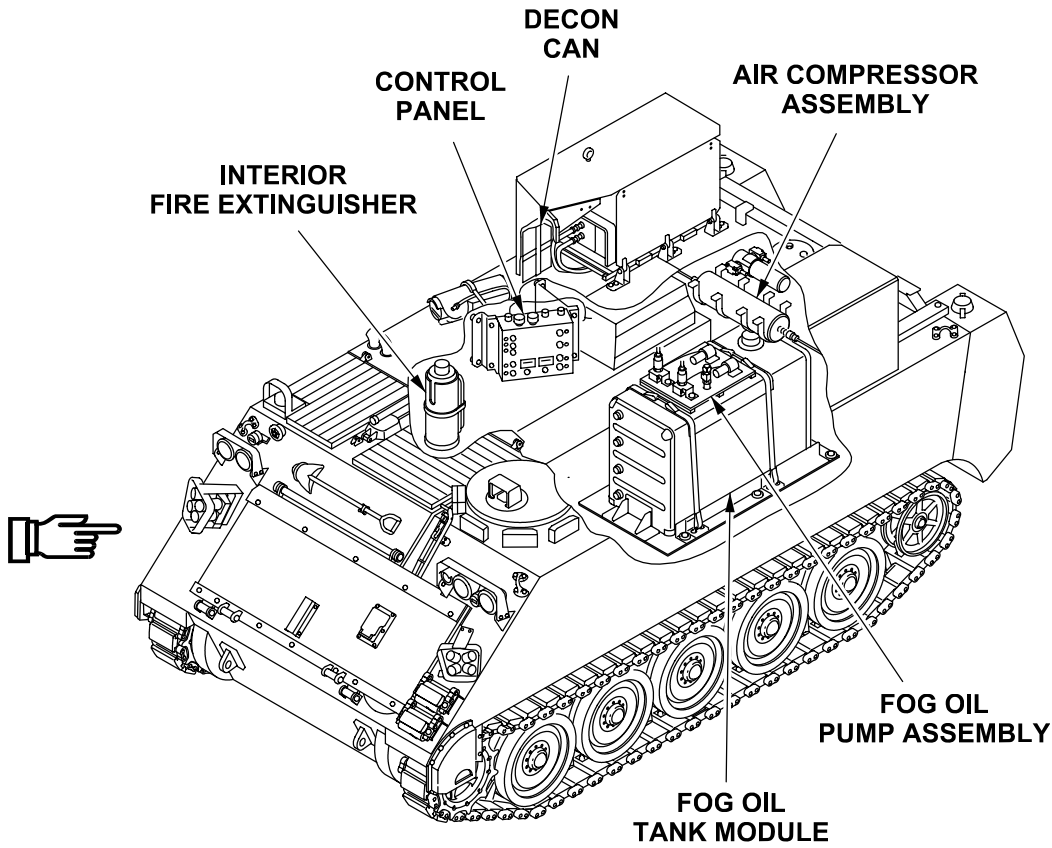

M1059A3 FULL TRACKED SMOKE GENERATOR CARRIER — SMOKE GENERATOR SYSTEM M157A2

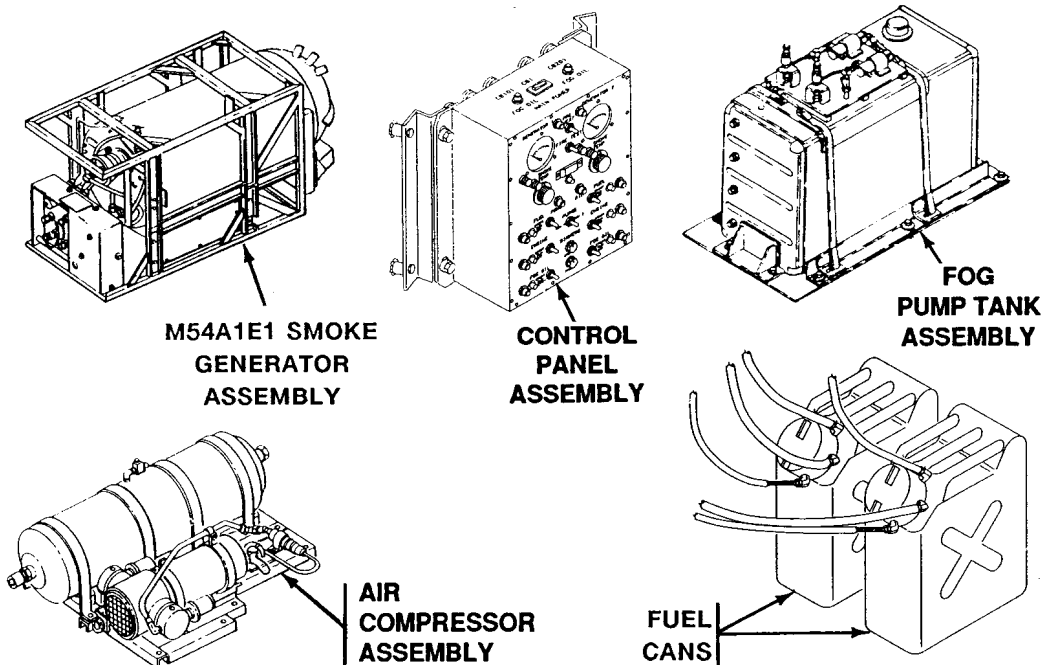

M58 MECHANIZED SMOKE OBSCURANT CARRIER

This carrier is designed to generate a smoke screen in the battlefield environment. The M58 carries a crew of three. A caliber .50 machine gun is mounted on a cupola on top of the carrier. See TM 3-1040-285-10 for operation of the Smoke Obscurant System. The M58's capabilities and features are:

- It travels easily over rough terrain.
- It fords water up to 40 inches (102 cm) deep.
- It can move at high speeds on improved roads and highways.
- It is air transportable and can be dropped by parachute to troops in the field.
- It is propelled and steered on land and in water by tracks.
- It has M17 periscopes around the driver's and commander's hatches for vision when buttoned up.
- It has a Driver's Vision Enhancer (DVE) stowed near the driver. The viewer can be installed in the driver's hatch to provide night vision under blackout conditions.
- It is equipped with smoke grenade launchers, an NBC (gas particulate filter) unit, and personnel heater kit (for cold weather operation).
- It is equipped to carry a driver's windshield kit and an engine coolant heater kit (for cold weather operation).
- It is equipped with a smoke obscurant system with enough IR for 30 minutes and fog oil for 1 1/2 hours of continuous operation.

M58 MECHANIZED SMOKE OBSCURANT CARRIER — LEFT FRONT VIEW

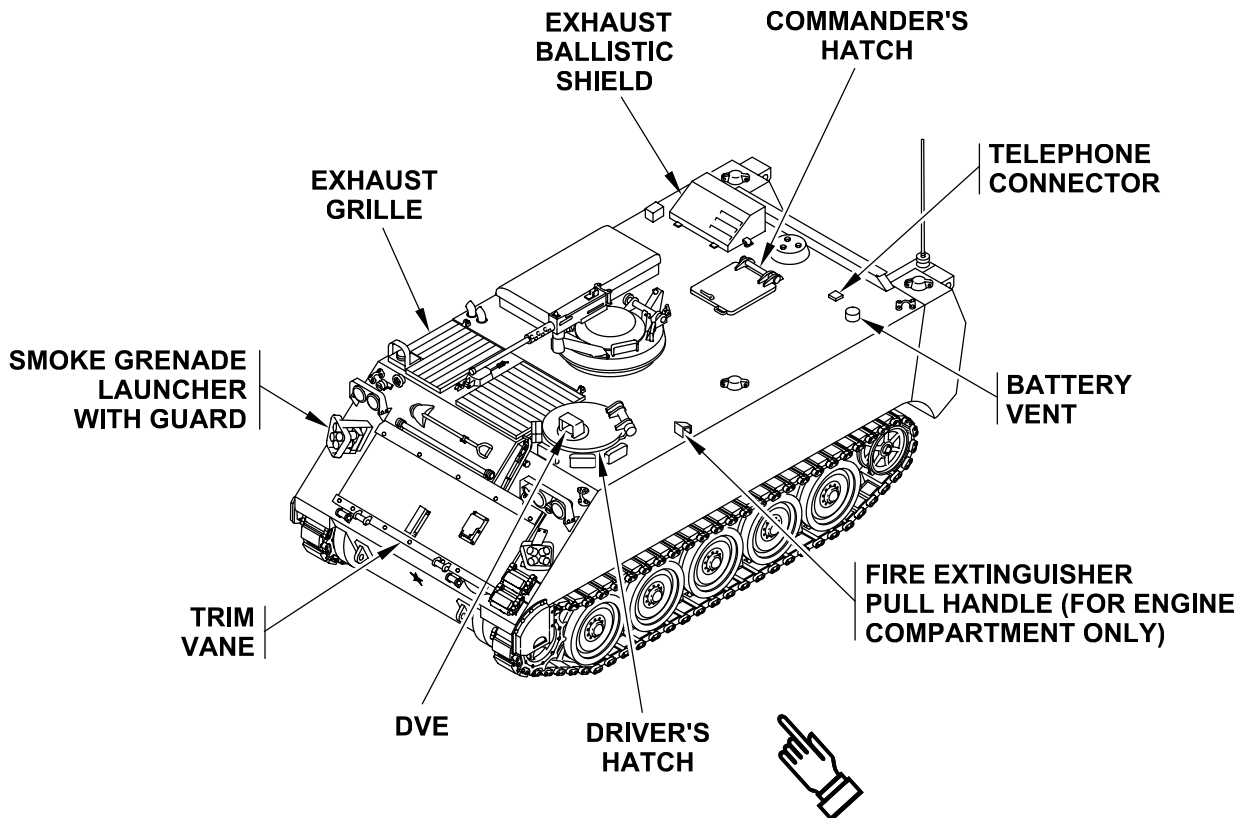

M58 MECHANIZED SMOKE OBSCURANT CARRIER — RIGHT REAR VIEW

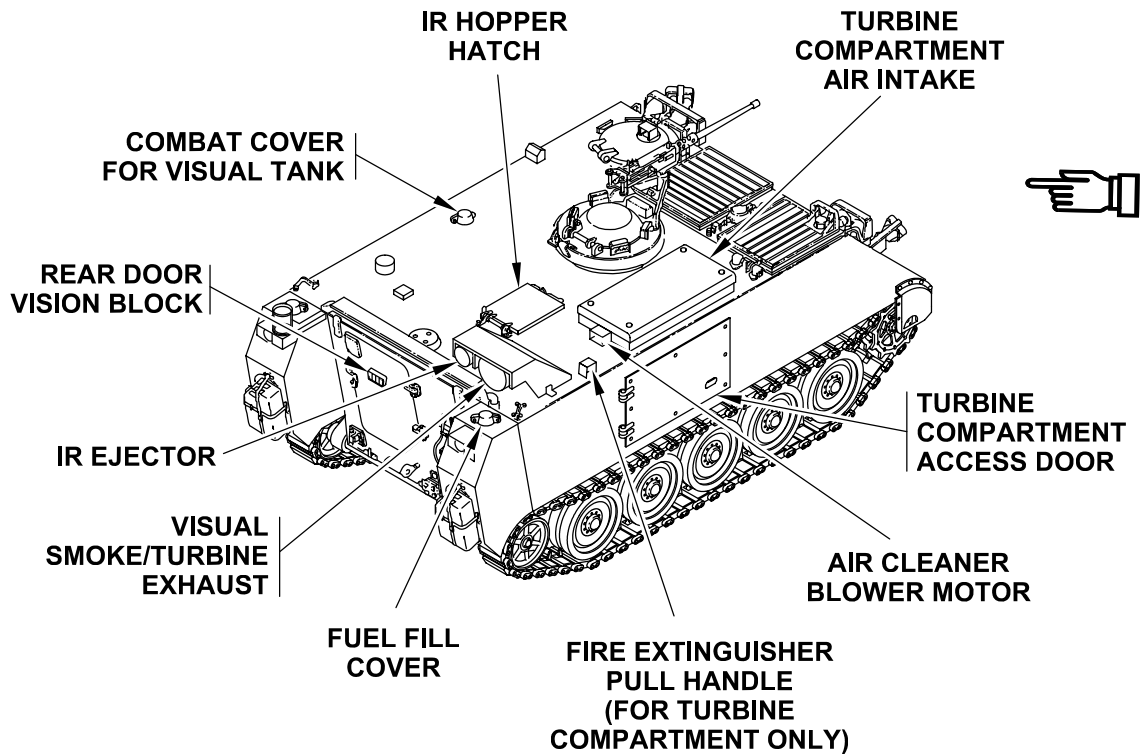

M58 MECHANIZED SMOKE OBSCURANT CARRIER — INTERIOR ARRANGEMENT

NOTE

See TM 3-1040-285-10 for full description and operation.

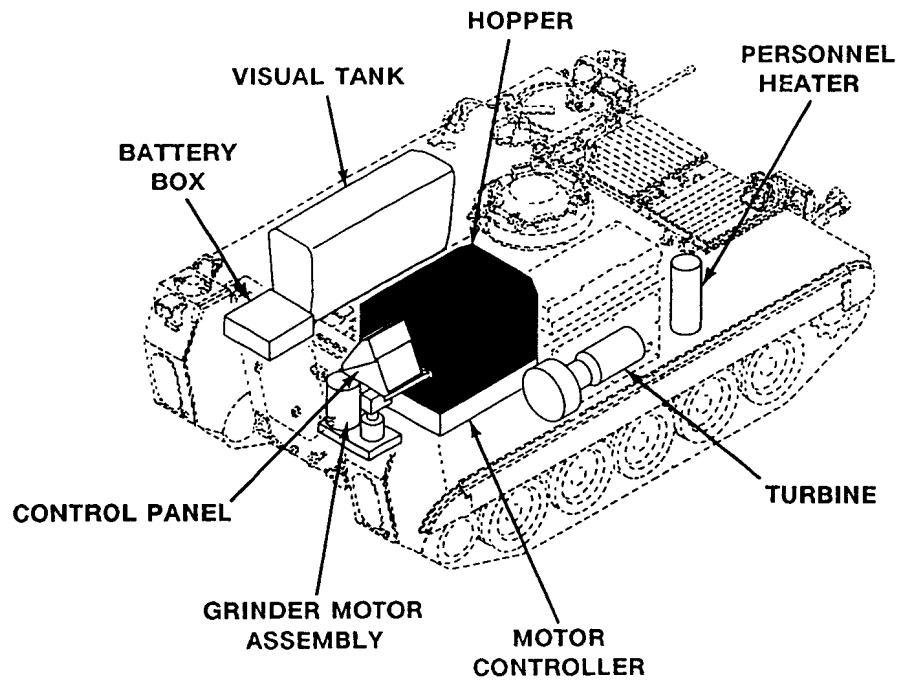

LOCATION AND DESCRIPTIONS OF MAJOR COMPONENTS**POWER PLANT COMPARTMENT — ALL CARRIERS**

The power plant compartment is located in the front of all carriers. It contains:

- Auxiliary coolant tank and fill for coolant/water to radiator
- Radiator
- Final drive dipstick and oil fill

Access to the power plant is through a front door, driver's compartment access panel, and rear compartment access panel. Access the differential, final drives, dipsticks, and oil fills by opening front access door.

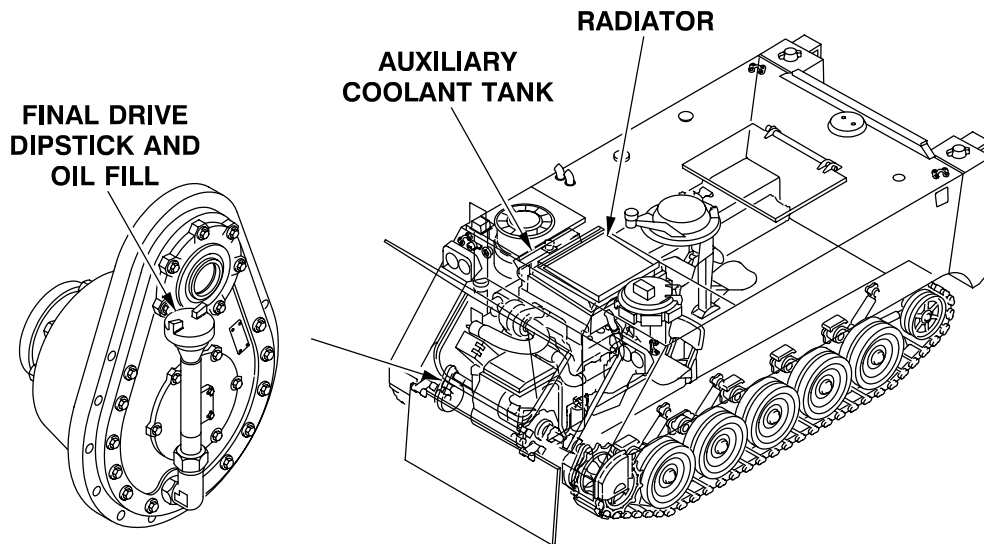

Removing the driver's compartment access panel provides access to the following:

- Engine
- Engine oil fill
- Engine oil dipstick
- Primary and secondary fuel filter drain cocks
- Transmission

The engine oil dipstick can also be reached by removing the rear access panel.

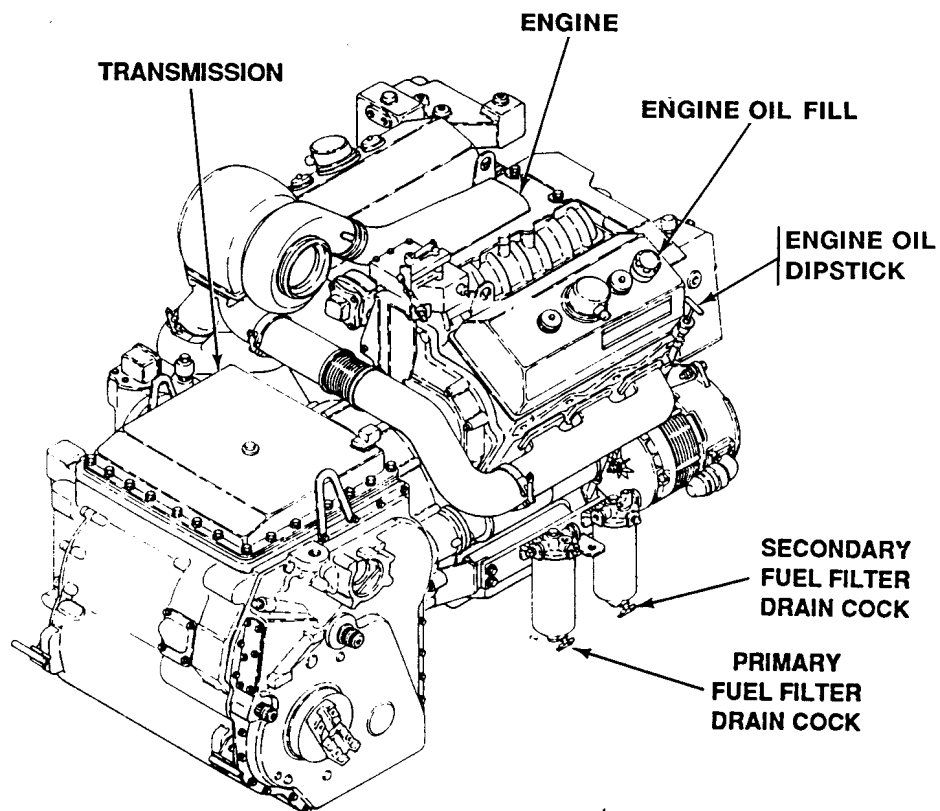

Removing the rear compartment access panel provides access to the following:

NOTE

There are two configurations for the transmissions. X200-4 is shown. X200-4A has a different dipstick configuration and a separate fill tube.

Transmission dipstick and oil fill
Ramp reservoir breather
Radiator
Fan oil sight glass
Generator drive belt
Fan drive belt
Ramp reservoir sight indicator
Engine oil filter

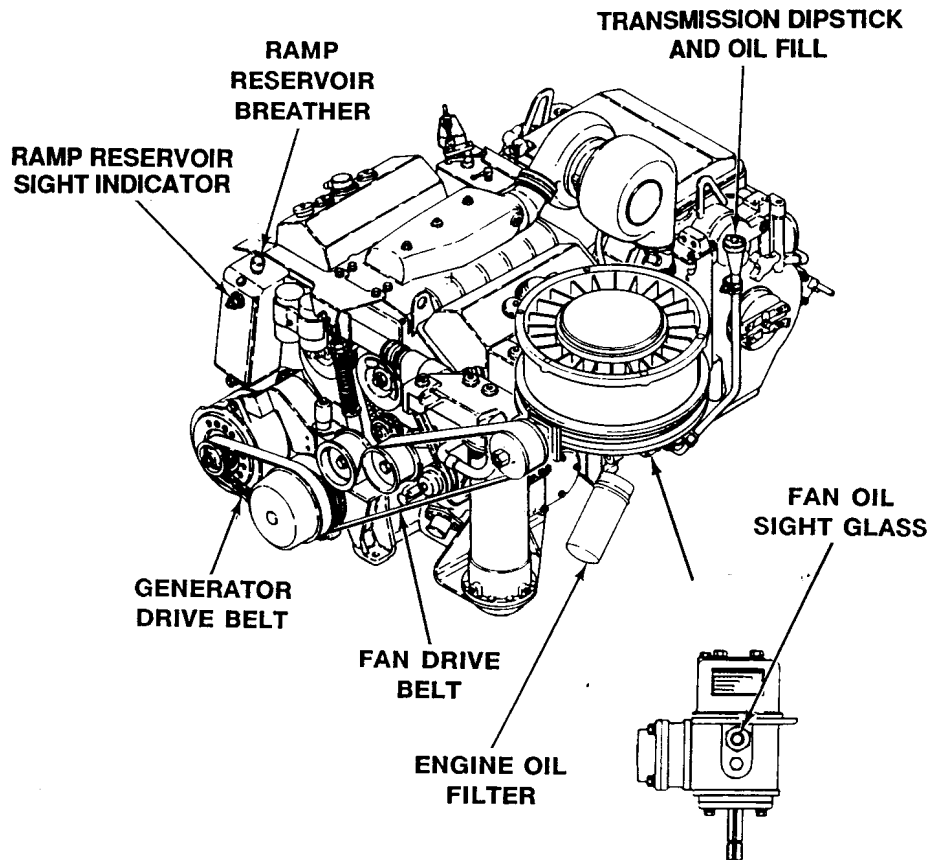

The power train consists of several major connected components. These include:

- 6V53T diesel engine — power source
- Transmission — automatically selects correct gear range
- Propeller shafts — connect final drives to transmission
- Final drives — drive the track drive sprockets
- Drive sprockets — power the tracks to move carrier

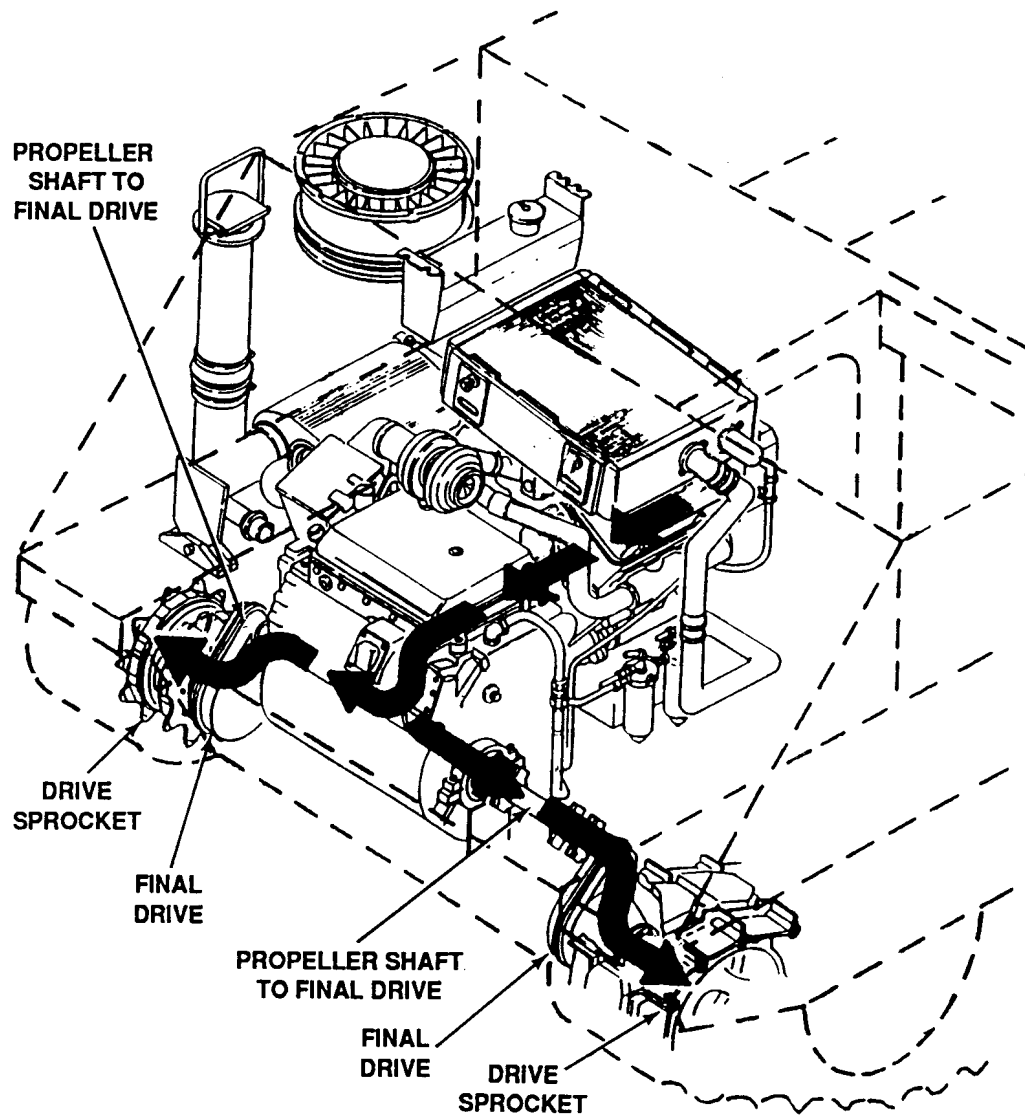

SUSPENSION SYSTEM — ALL CARRIERS

The carrier moves on its suspension system which includes the following components:

- Road wheels — ten on each side to support weight of carrier
- Road wheel arms — five on each side splined to individual torsion bars to suspend carrier
- Torsion bars — firmly anchored to carrier to keep road wheels on ground
- Tracks — on each side driven by final drive sprockets to propel carrier
- Track adjusters — secured to idler wheels to maintain track tension
- Shock absorbers — at first, second, and fifth road wheels to stabilize carrier
- Track idler wheel — adds tension to track when grease is pumped into track adjusters
- Final drive sprocket — power the tracks to move the carrier

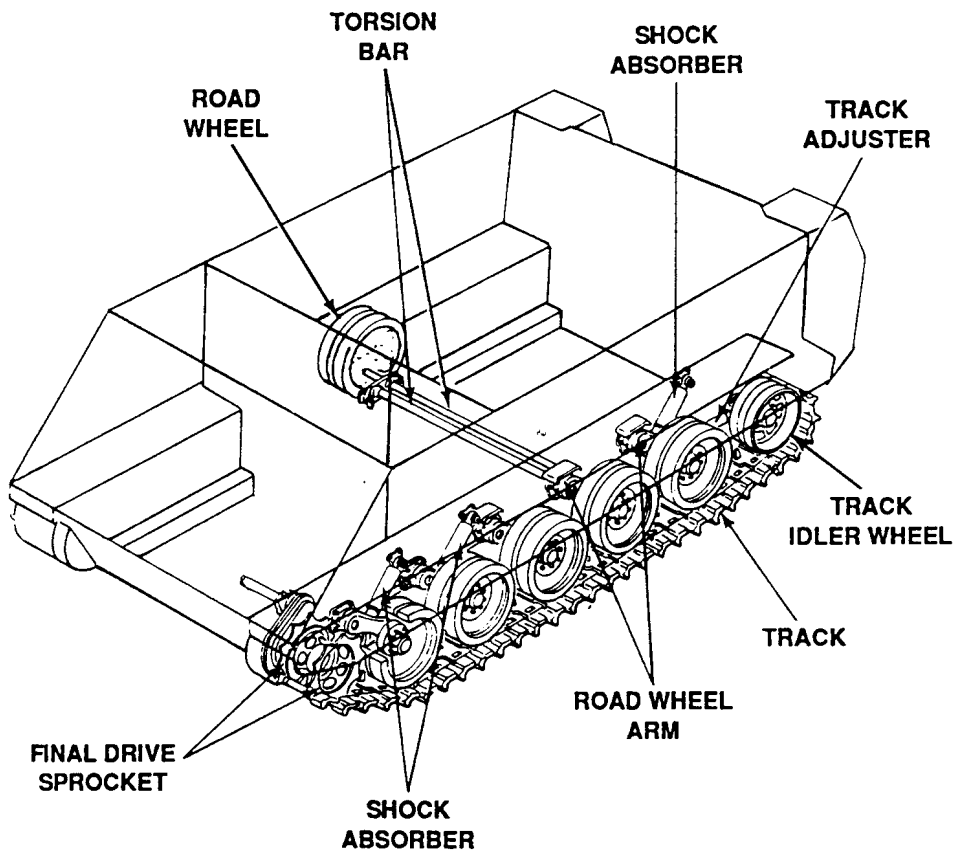

TRIM VANE

When extended, the trim vane helps stabilize the carrier during fording operations in small bodies of water.

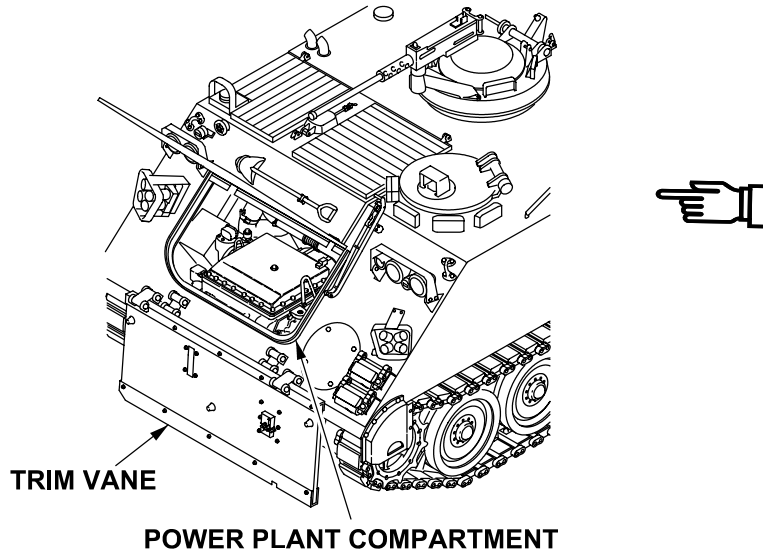

BILGE PUMPS

There are two bilge pumps. The forward pump is in the left front corner of the power plant compartment. The rear pump is under the floor plates on the right rear side of the carrier. When turned on, they remove water that may leak in during fording operations.

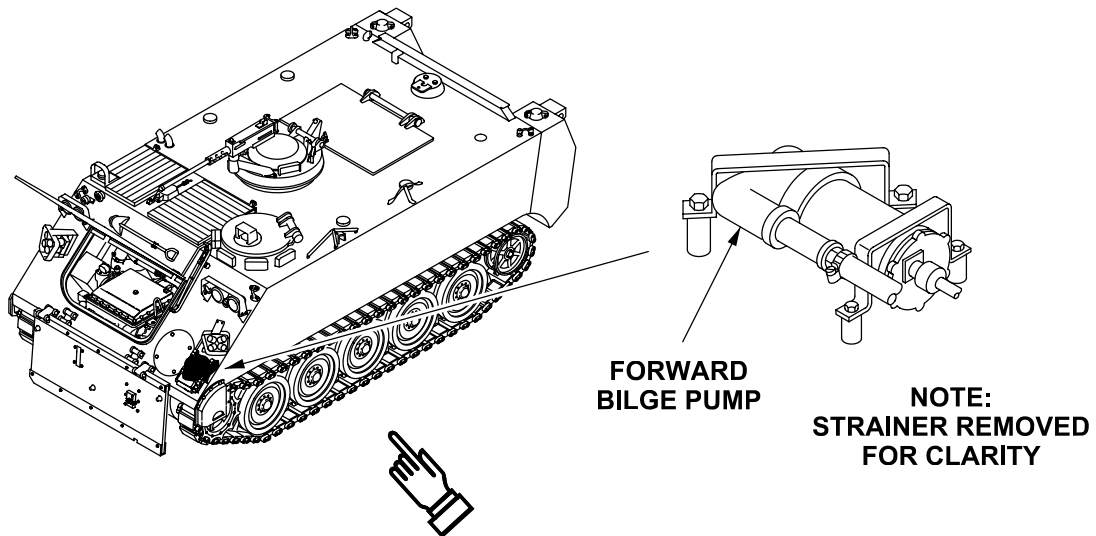

RAMP

The ramp is located at the rear of the carrier to permit rapid entry and exit.

FUEL TANK EXTERNAL

The external fuel tanks for the M113A3, M1059A3, M58, and M1064A3 carriers are mounted on the left and right rear corners of the carrier. Both tanks supply diesel fuel to the engine through a single main fuel line.

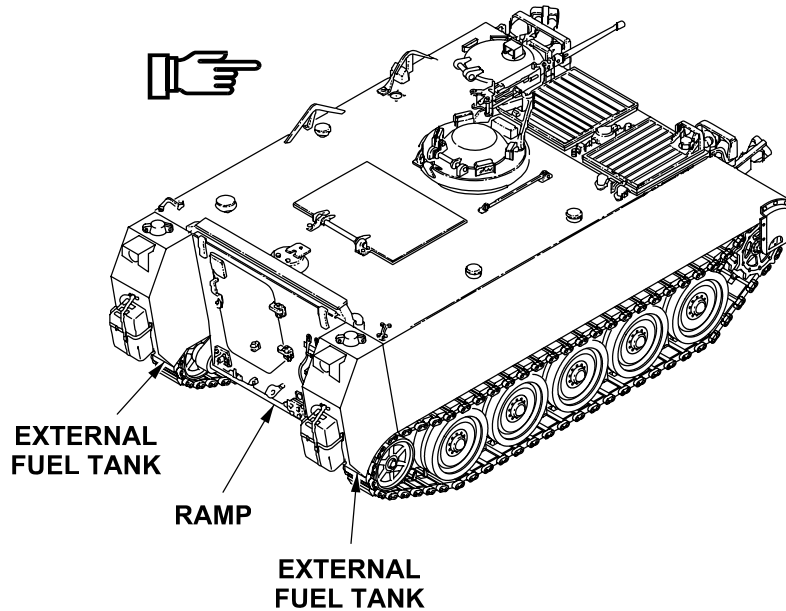

FUEL TANKS INTERNAL

The internal fuel tanks for the M577A3 and M1068A3 carriers are mounted on the left and right sponsons with tables on top of them. Both tanks supply diesel fuel to the engine through a single main fuel line. The shutoff valve is under the rear floor plate.

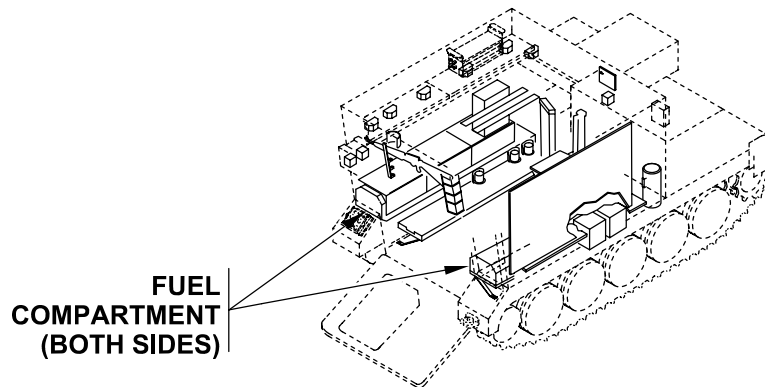

FIXED FIRE EXTINGUISHERS

The fixed fire extinguisher releases CO² to quickly put out fires in the power plant compartment. It can be manually activated by a control on the fire extinguisher bottle or by the handle on the carrier left top deck, on all M113A3 FOV vehicles. The M58 has a second fixed fire extinguisher located on the right side of the vehicle to put out fires in the turbine compartment. It can be manually activated by a control on the fire extinguisher bottle or by the handle on the carrier right top deck.

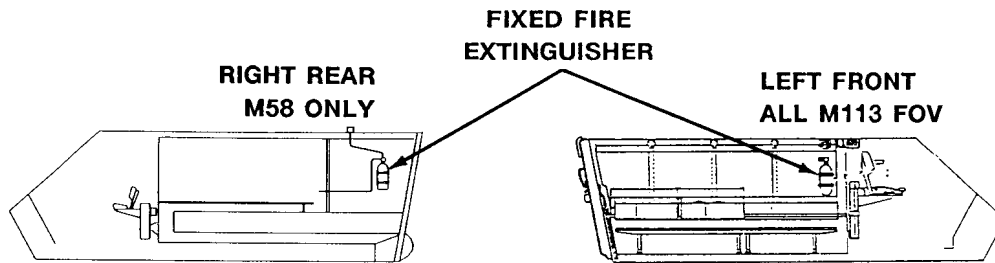

EXTERIOR LIGHTING

Exterior lights include service headlights, infrared headlights, blackout marker lights, blackout headlight, and taillight-stoplight.

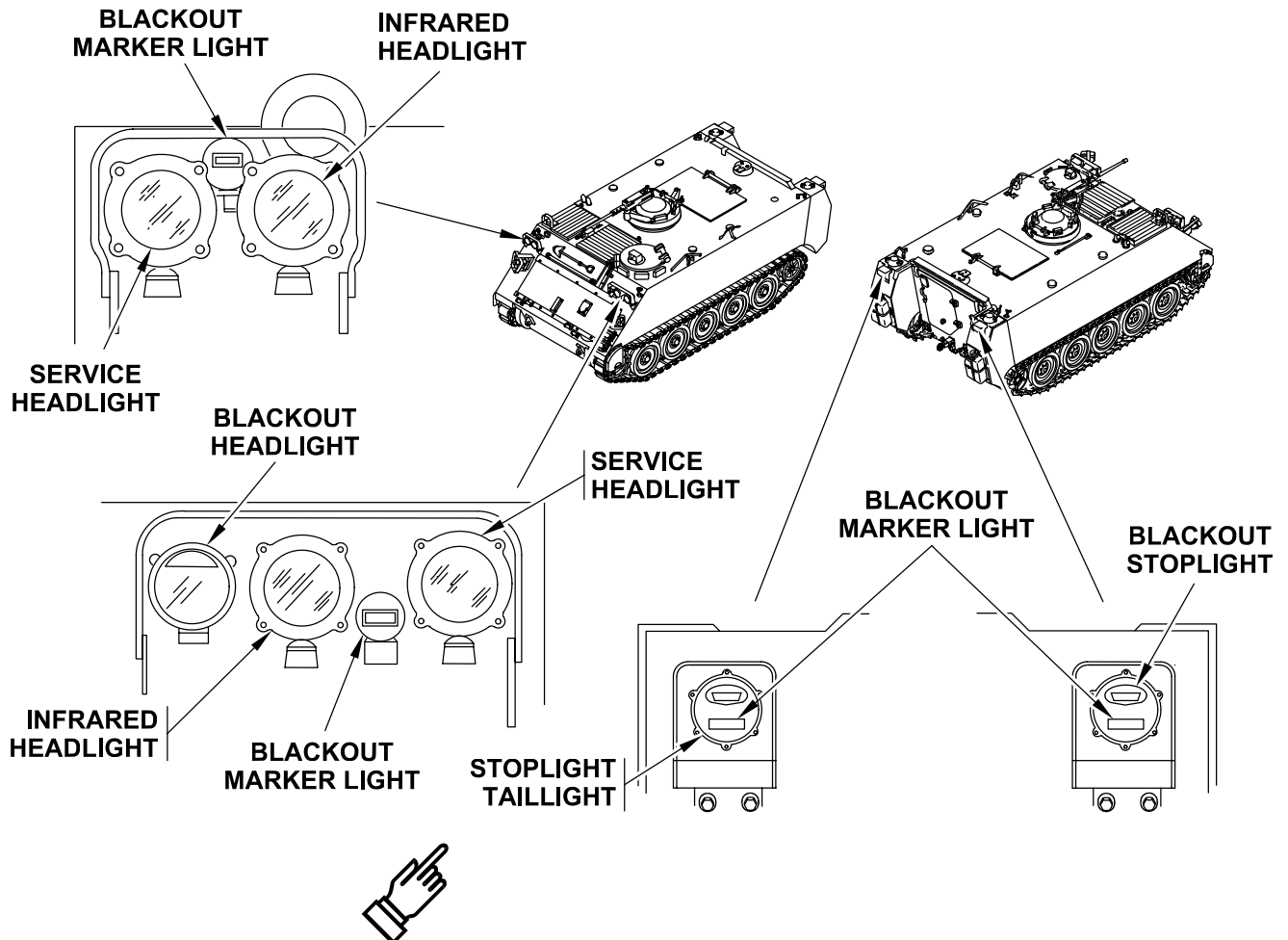

SEATS

The M113A3 is equipped with separate seats for the driver and the commander. A jump seat is located adjacent to the commander's seat. Personnel seats located on either side of the personnel compartment provide seating for 10 combat equipped soldiers.

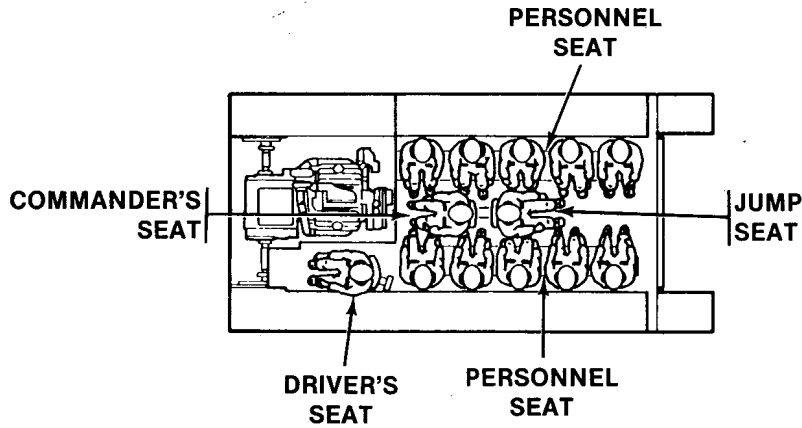

SPALL LINERS

The M113A3 only is equipped with spall liners to protect against the effects of armor piercing rounds that may penetrate the exterior armor plate. Acting as a barrier against flying metallic chips, the liners improve the survivability of the personnel and the carrier.

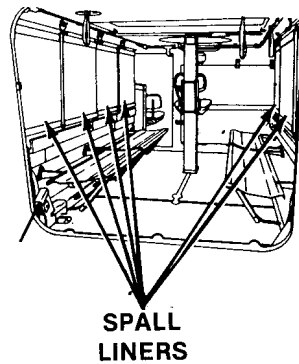

ENGINE COOLING AND AIR INDUCTION — ALL CARRIERS

Air for engine combustion and cooling is drawn through the intake grille and radiator. Air sweeps down around the power plant and out through the exhaust grille above the fan. Fresh air is drawn through the intake grille for the air cleaner. Keep the intake grille clear of debris to help the radiator get all the air it can get. The same applies for the air cleaner which supplies fresh clean air to the engine. The air cleaner is equipped with a restriction indicator to inform the driver when the air cleaner element needs cleaning.

WARNING

Failure to open ventilator, when operating carrier with all hatches closed, will result in a serious lack of oxygen.

CAUTION

Avoid overheating of components during operation. Keep power plant door, access plates, and panels closed tightly for correct air flow.

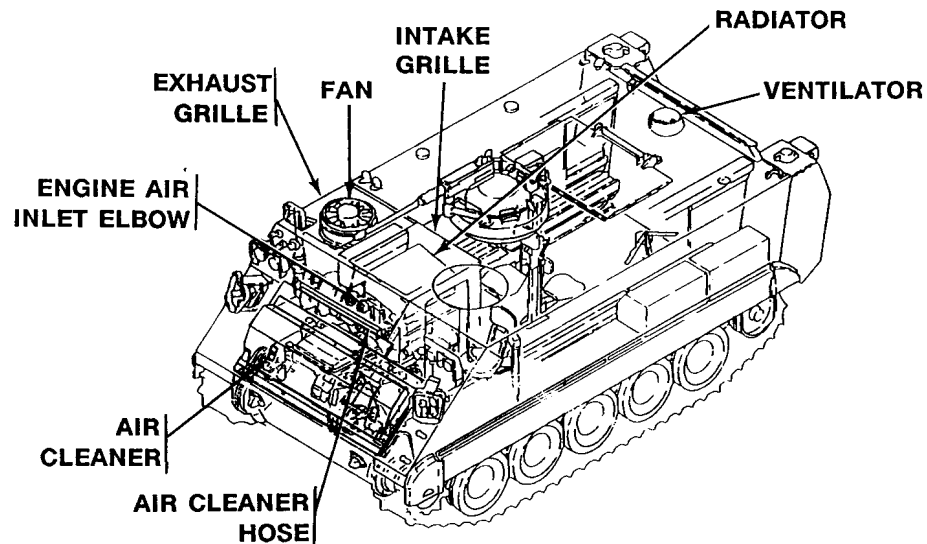

AUXILIARY POWER RECEPTACLE (M577A3 AND M1068A3 ONLY)

The auxiliary power receptacle, on top deck next to driver's hatch, provides for use of 24-volt DC power from an outside source to start engine, charge batteries, and operate electrical equipment (WP 0022 00).

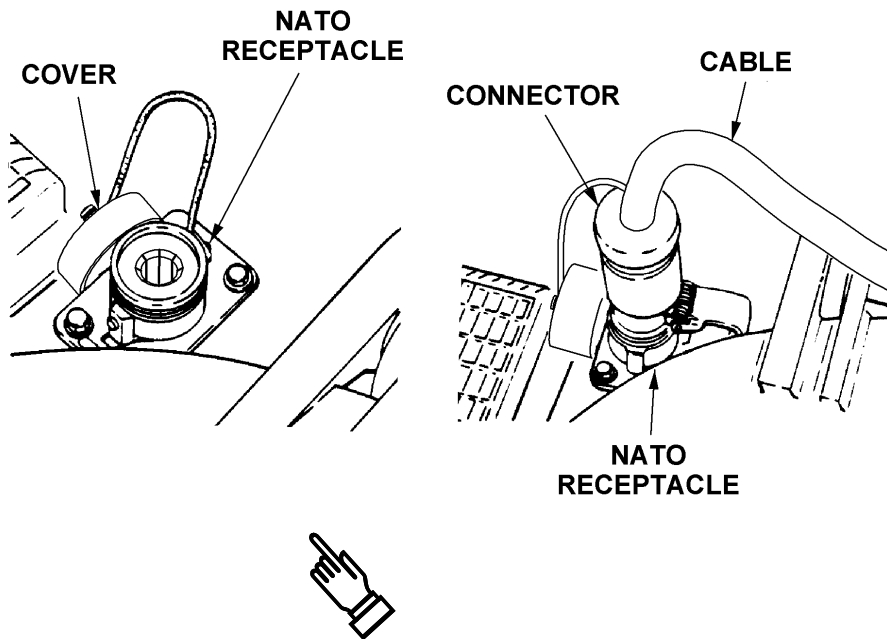
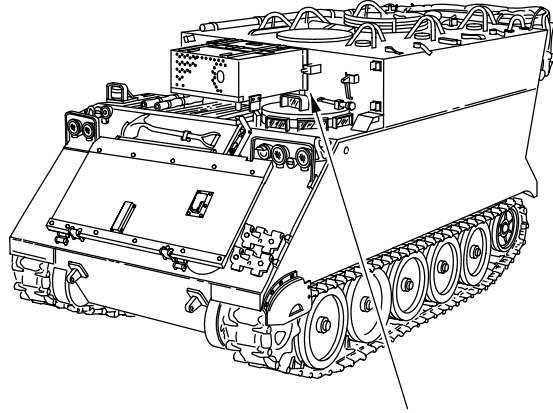

MASTER SWITCH PANEL (M577A3 AND M1068A3 ONLY)

The master switch panel is located below the instrument panel and mounts the master switch, infrared (I.R.) stowage receptacle, utility outlet, fuel tank selector switch, compartment blower ON-OFF switch, and front dome light switch.

The fuel selector switch is set left or right to read the quantity of fuel in either tank. The compartment blower ON-OFF switch controls the compartment blower. The front dome light switch controls the dome lights.

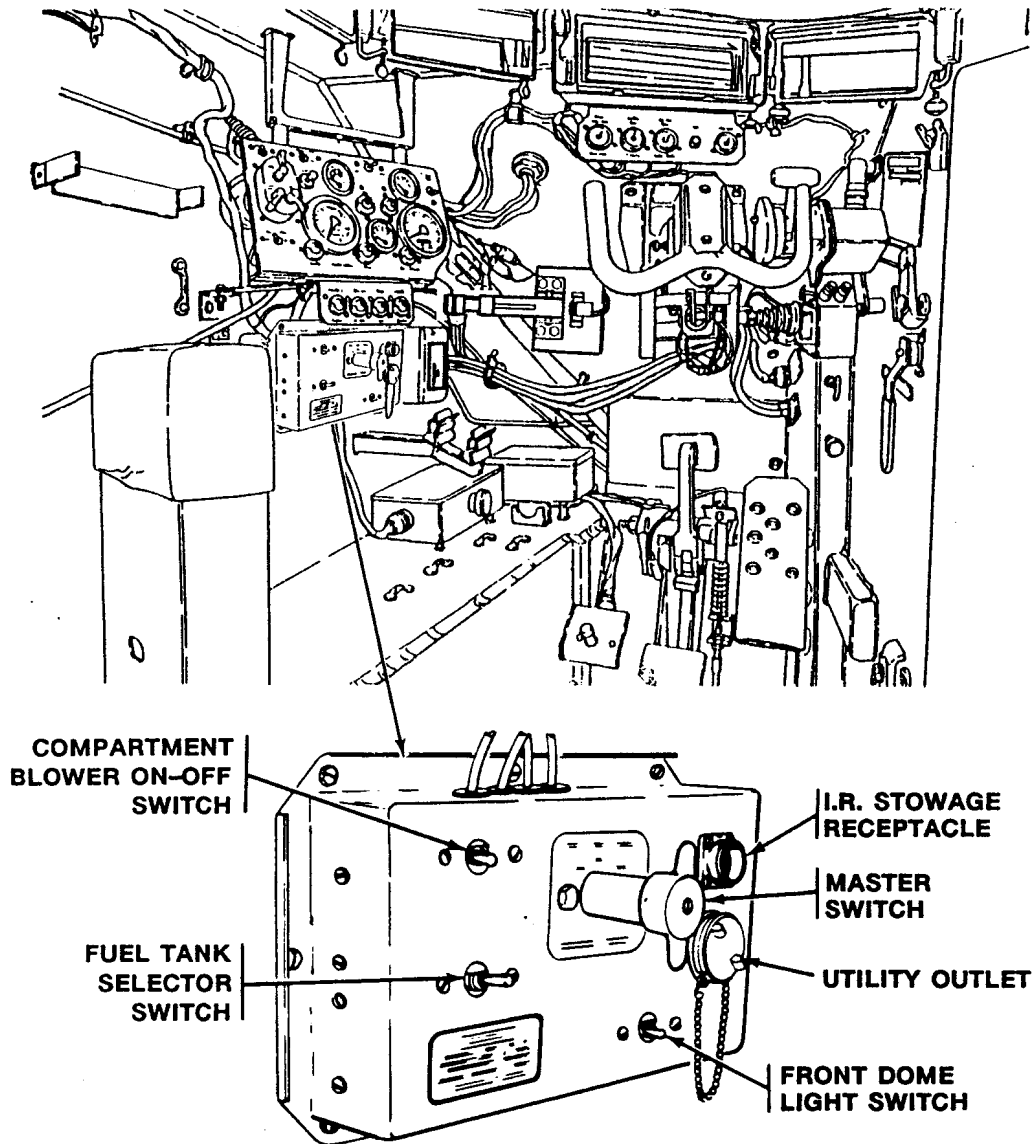

DOMES LIGHTS AND SWITCHES (M577A3 AND M1068A3 ONLY)

The command post has nine dome lights (white lens) and two blackout dome lights (red lens) mounted on the ceiling. Each light can be adjusted individually.

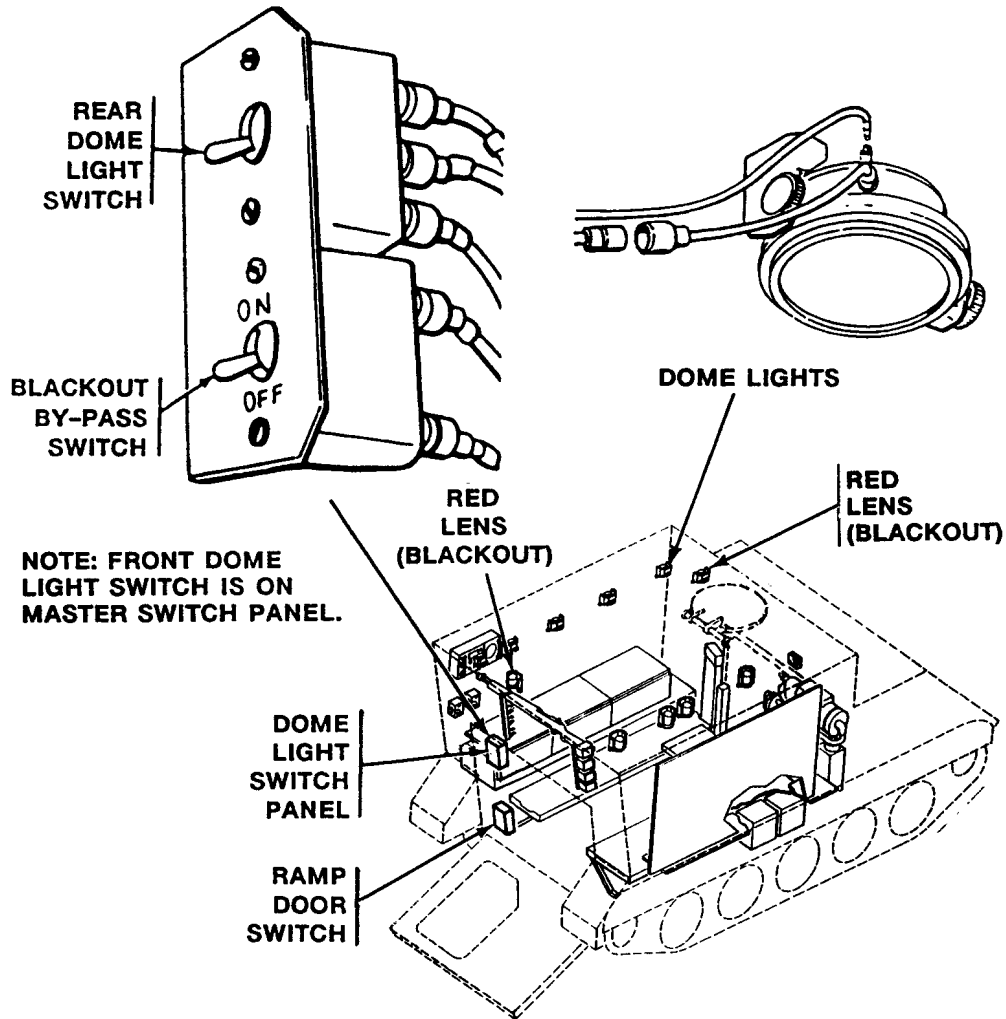

Turn on dome lights from either the front dome light switch (on master switch panel) or at the rear dome light switch near the ramp. To do this, the blackout by-pass switch must be OFF, the ramp up, and the rear door closed.

If the rear door is open, the ramp door switch automatically cuts off current to the nine dome lights (white lens) and directs current to the two blackout dome lights (red lens). The two blackout dome lights will then turn on or off depending upon the position of the dome light switch.

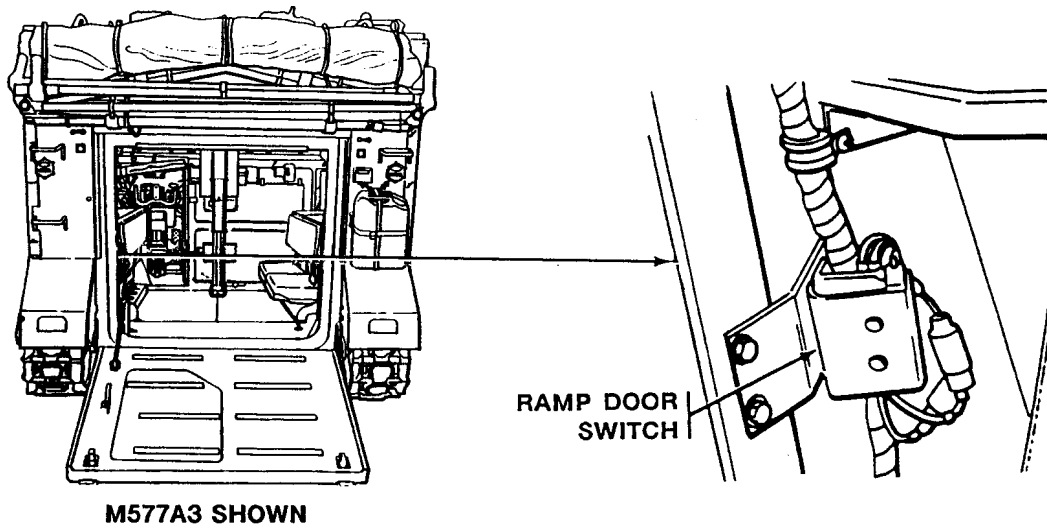

ADMITTANCE BUZZER SWITCH (M577A3 AND M1068A3 ONLY)

Press the admittance buzzer switch to alert personnel inside the carrier so they can make sure the blackout lights are on before you enter the carrier.

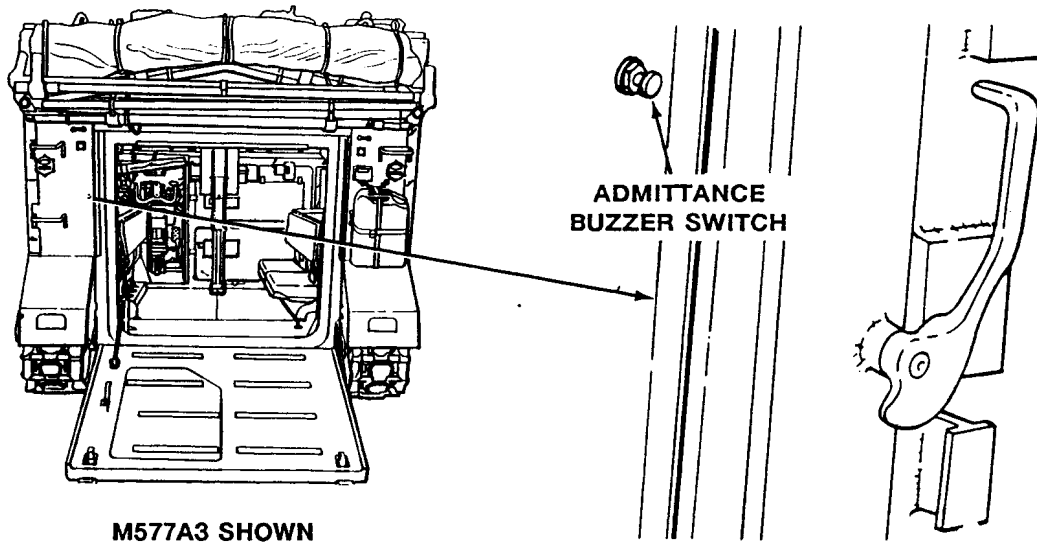

ARTILLERY COMMUNICATION CABLES (M577A3 ONLY)

When the M577A3 is operated as an artillery command post, the artillery communication cable plug on left rear hull plate is removed. Two cables (one inside carrier, one outside) connect with terminal boards to complete the communication network.

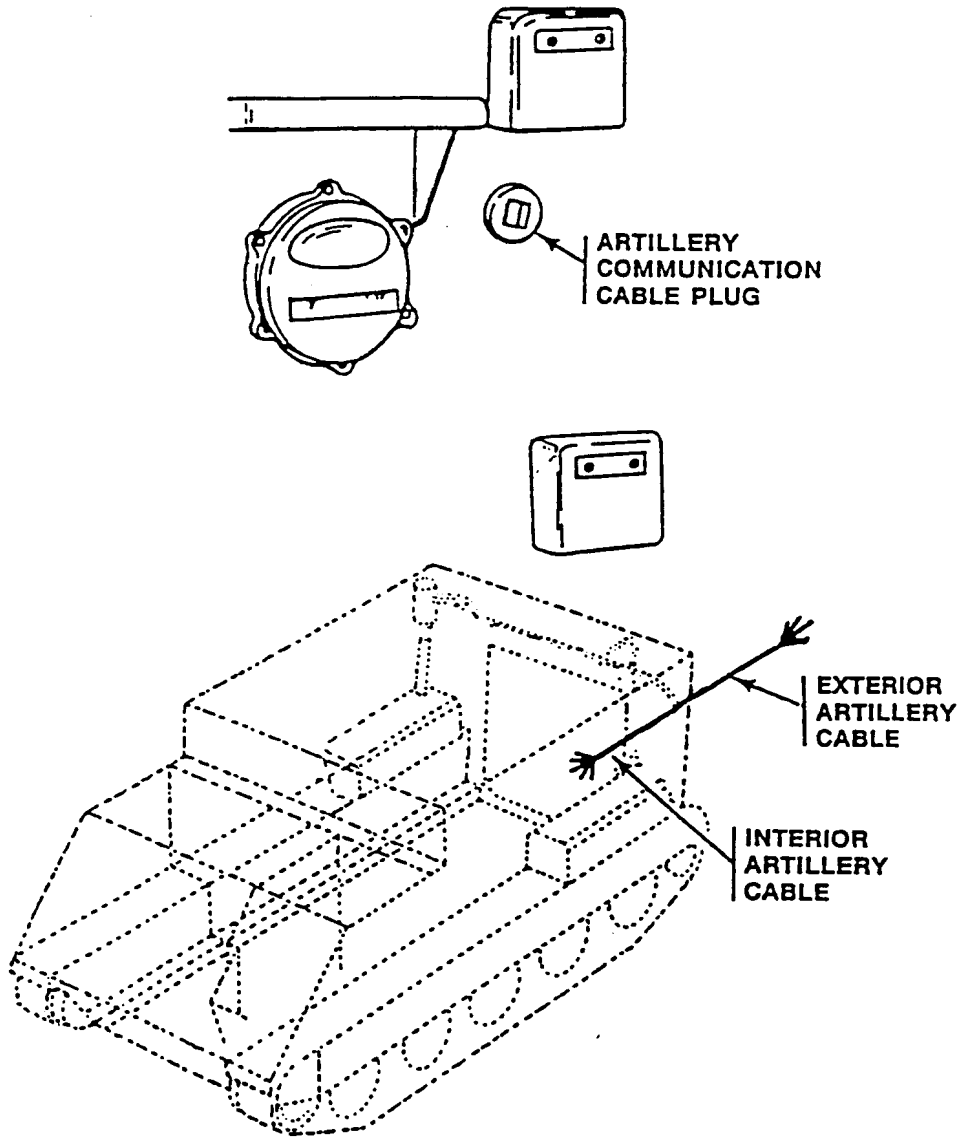

COMMUNICATION RECEPTACLES AND UTILITY OUTLETS (M577A3 ONLY)

Seven communication receptacles, three forward, one center, two rear, and one near the right radio rack, are used to hook up the radio and telephone lines.

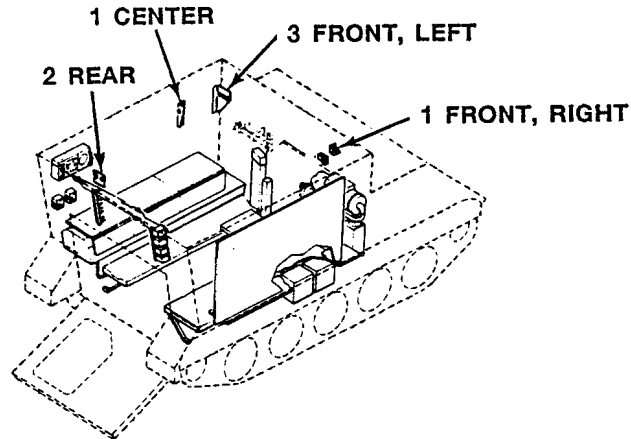

Two utility outlets, one on each side of the ramp, are used to operate 24-volt accessories or to light the tent.

**UTILITY OUTLETS
(TENT ELECTRICAL CONNECTIONS)**

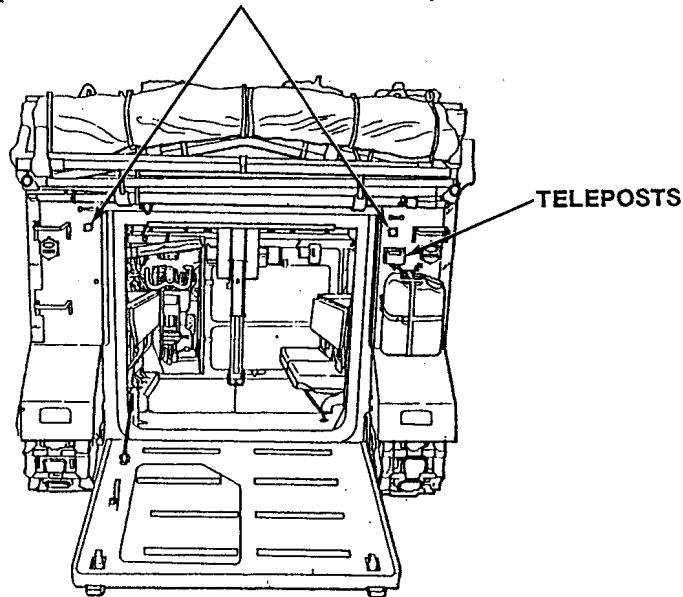

ANTENNA MAST BRACKETS (M577A3 AND M1068A3 ONLY)

The antenna mast brackets mounted behind the driver's hatch are used to mount the RC292 antenna. The RC292 is a ground plane whip antenna that will increase the communication range of the radio sets. It consists of a 30-foot (9 m) mast, a 68-foot (21 m), 50-ohm lead-in cable, and antenna sections.

WARNING



If antennas touch electric power lines, you could be electrocuted. Make sure radio antennas have clearance when carrier is operating near electric power lines.

Place antenna in mounting brackets. Remove and stow pipe plug from top deck, and insert antenna lead through hole. Connect lead to radio as shown in TM 11-5820-348-15.

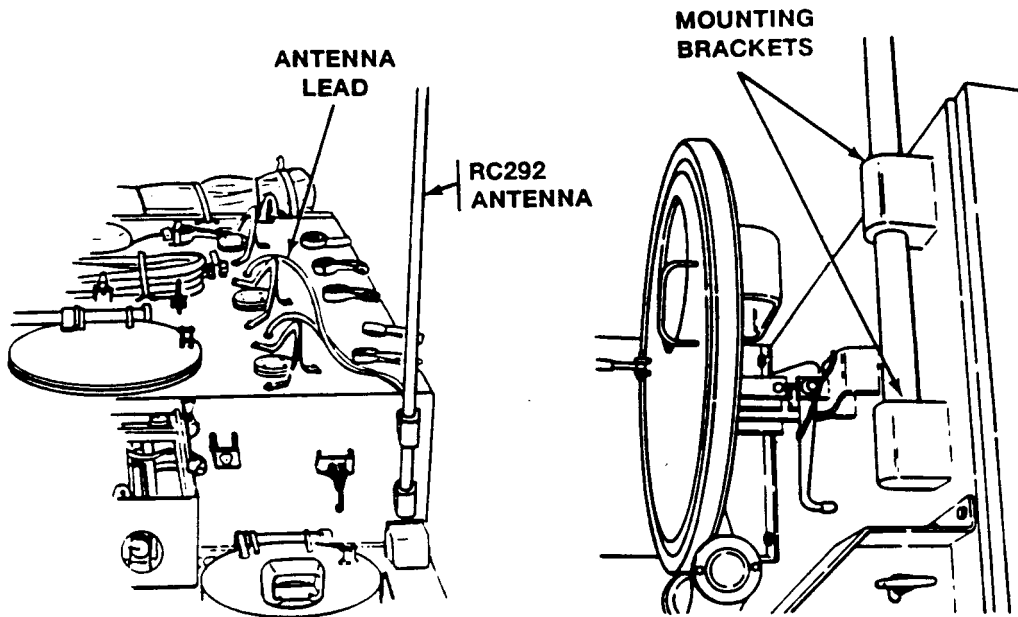

POWER ENTRY BOX ASSEMBLY — M1068A3 ONLY**WARNING**

When using external power, ensure proper grounding procedures are followed. Failure to do so may result in personal injury and/or damage to the equipment. See TM 11-7010-256-12&P for installing surface wire grounding system.

WARNING

HIGH VOLTAGE is used in the operation of this equipment.

DEATH ON CONTACT may result if personnel fail to observe safety precautions.

NEVER work on equipment unless at least one other person familiar with the operation and hazards of the equipment is nearby. That person should also be competent in giving first aid. When an operator helps a technician, that operator must be warned about dangerous areas.

SHUT OFF POWER supply to equipment before beginning work. When working inside equipment with power off, take special care to ground every capacitor likely to hold a dangerous potential.

BE CAREFUL not to contact high-voltage connections when installing or operating this equipment.

KEEP one hand away from the equipment to reduce the hazard of current flowing through life-sustaining organs of the body.

The power entry box assembly, located at the upper rear roadside exterior corner of the carrier, along with cable W1 (external power input pigtail), and cable W2 (external AC power cable), provides the ability to receive or supply AC power. A workstation can be powered by using the on-board generator, external power source, or the carrier's charging system.

The assembly has connections for AC power out and external power in. By connecting either cable W1 or W2 to the assembly connections, the carrier can act as an alternate power source or receive power from some other alternate power source.

Cable W1 and W2 are located just behind the generator on top of the carrier. Cable W2 has connectors on both ends which allow it to be connected between other systems. Cable W1 has a connector on one end and pigtails (loose wires) on the other end. This allows connection to power sources other than a common system. Cables W1 and W2 can also be connected in series when additional length is required.

Connections for cable W1 pigtails are:

Items in parenthesis identify labels on each wire.

- Circuit 1 to HOT (Power)
- Circuit 2 to Neutral (Neutral)
- Circuit 3 to Ground 1 (GND 1)
- Circuit 3 to Ground 2 (GND 2)

When operating on carrier power, only essential systems should be operated to avoid overloading the power requirements.

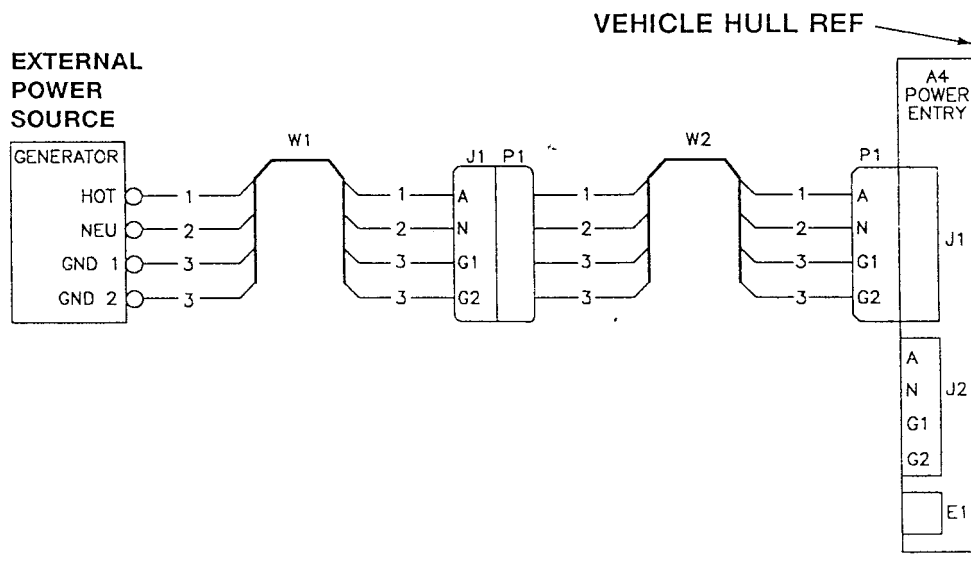

MATERIAL USED WITH CARRIERS

Various kits can be applied to your carrier to prepare it for particular missions or operating conditions. Each kit is described and illustrated on the following pages. If you have one or more of these kits on board, be sure to check the PREVENTIVE MAINTENANCE CHECKS AND SERVICES (WP 0090 00). These kits include:

- Personnel Heater Kit — All Carriers
- Engine Coolant Heater Kit — All Carriers
- Hospital Litter Kit — M113A3 Only
- Windshield Kit — All Carriers
- Gas Particulate Filter Unit M8A3 (NBC Kit) — All Carriers
- Capstan and Anchor Kits — M1059A3
- Smoke Grenade Launcher Kit — M113A3, M1059A3, and M58
- Water/Ration Kit — M113A3 and M577A3

PERSONNEL HEATER KIT — ALL CARRIERS. Provides heat to the rear compartment and driver's compartment during cold weather. It circulates warm air from the fresh air heater mounted in the right front corner of the rear compartment. A heat duct along the front floor is manually controlled to direct the heat. Heater intake air is drawn from outside. The exhaust is vented through the top deck. The heater control box is mounted to the left of the driver. It has a three-position RUN-OFF-START switch, HI-LO switch, and indicator light. Location of the fuel pump for the personnel heater varies with each vehicle (see illustration).

Heaters with part numbers D55350-F1 and 10560M24B1 are covered in this manual. For description, operation, and troubleshooting of personnel heater, model A20, with part number 5000-30178, see TM 9-2540-207-14&P.

WARNING



Inspect heater fuel lines for leaks. **DO NOT** operate heater with a bad fuel line. You could be badly burned.

WARNING

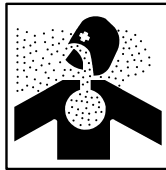

Heater exhaust fumes contain deadly poisonous gases. Severe exposure can cause death or permanent brain damage. Turn heater off if you smell or suspect exhaust gas inside personnel compartment.

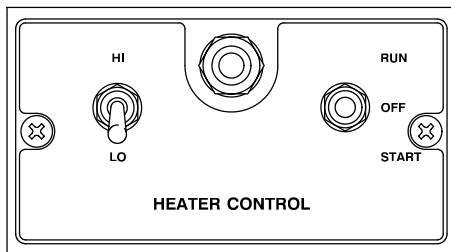

HEATER CONTROL BOX

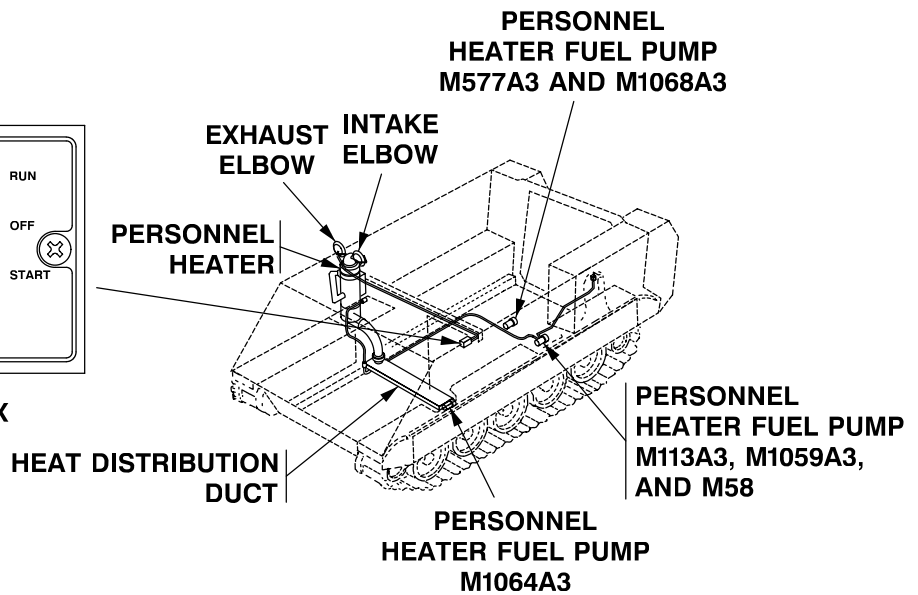

ENGINE COOLANT HEATER KIT — ALL CARRIERS. Heats and circulates coolant through the engine and battery box heat exchanger. After stopping a warm engine, the heater is started. It will keep engine oil, engine block, and batteries warm for 12 hours and permit restarting engine. The coolant heater is mounted in the power plant compartment. A coolant pump circulates coolant through tubing to the engine and battery box heat exchanger. The control box is mounted to the left of the driver. It has a three-position RUN-OFF-START switch, HI-LO switch, and indicator light. Coolant shutoff valves, at heater and engine block, control flow of coolant into heater.

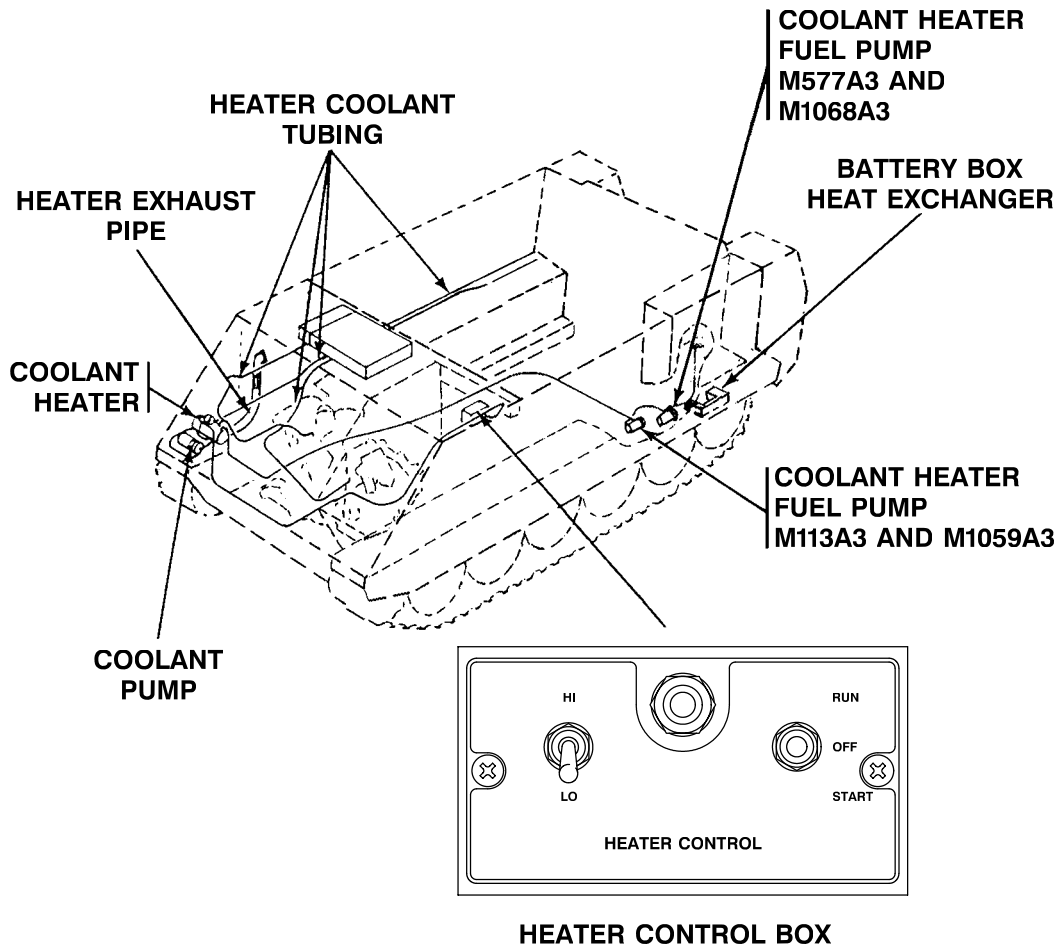

HOSPITAL LITTER KIT — M113A3 ONLY. Converts the M113A3 carrier into an ambulance to carry sick or wounded personnel. The kit has four support post and four chains. These can be attached to brackets and eyes in the rear compartment. When in place, the posts support two litters on each side above the personnel seats.

NOTE

Remove machine gun and all ammunition when operating M113A3 as litter carrier. It is also recommended that the commander's seat and platform be removed. Display a red cross symbol on outside of carrier.

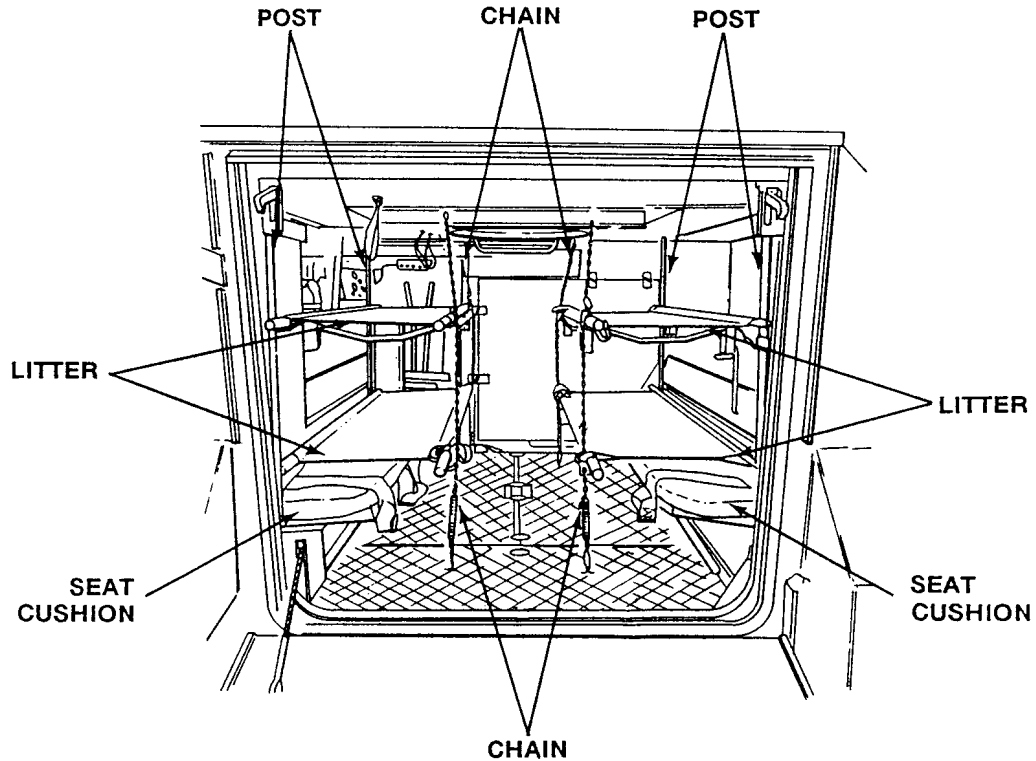

WINDSHIELD KIT — ALL CARRIERS. Provides driver with protection from cold winds when driving with hatch open. It has five windows curved around the driver's hatch and is removable. When not in use, kit is placed in stowage bag and stowed in carrier. See stowage diagrams (WP 0105 00).

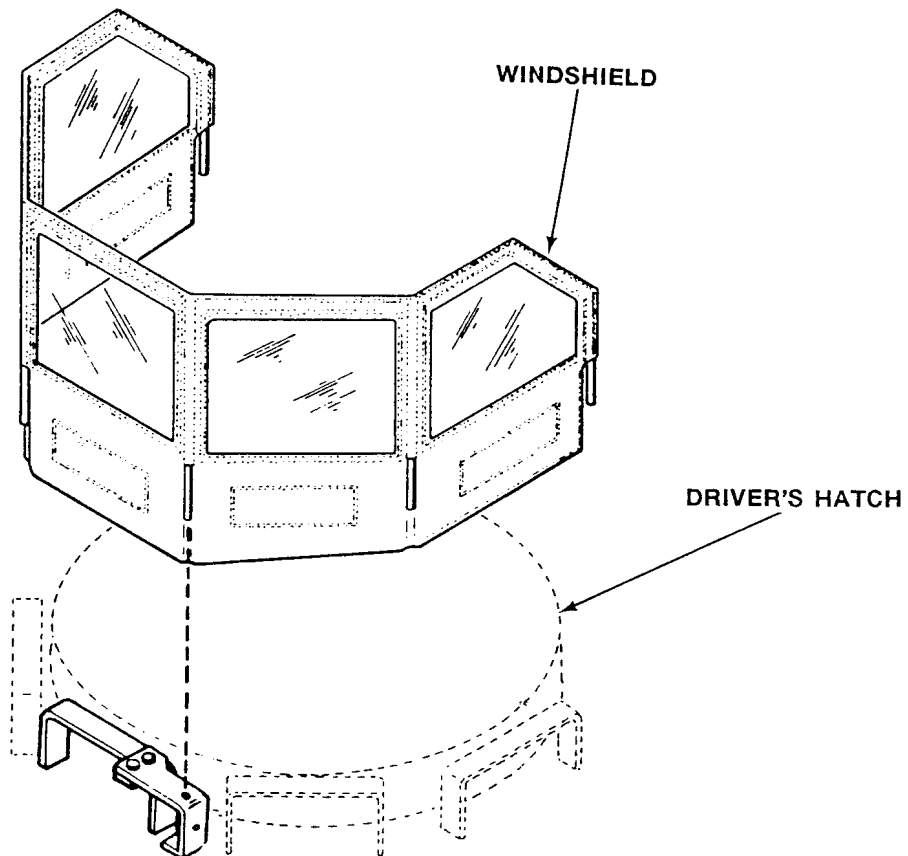

GAS PARTICULATE FILTER UNIT (NBC KIT) — ALL CARRIERS. Provides a filter unit and gas masks for protection against Nuclear, Biological, and Chemical attacks. All carriers except M577A3 have resilient rubber mounts on which to mount the purifier unit. The M577A3 purifier unit is mounted to the blackout curtain frame. The NBC filter kit consists of an M2A2 air purifier and four hose assemblies that carry purified air to the gas mask (or hospital hood protector headpiece for M113A3 only). The circuit breaker and switch assembly are connected between the carrier power source and the motor in the air purifier. For further information, see TM 3-6680-316-10.

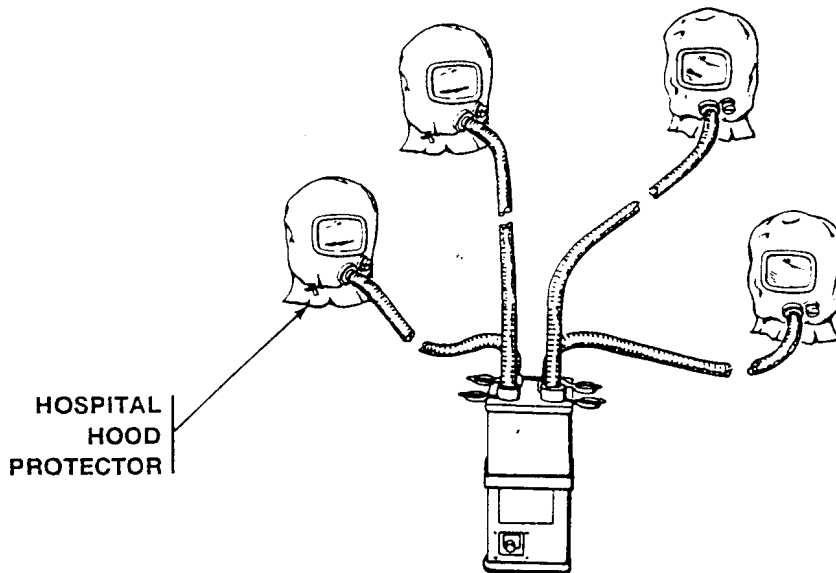
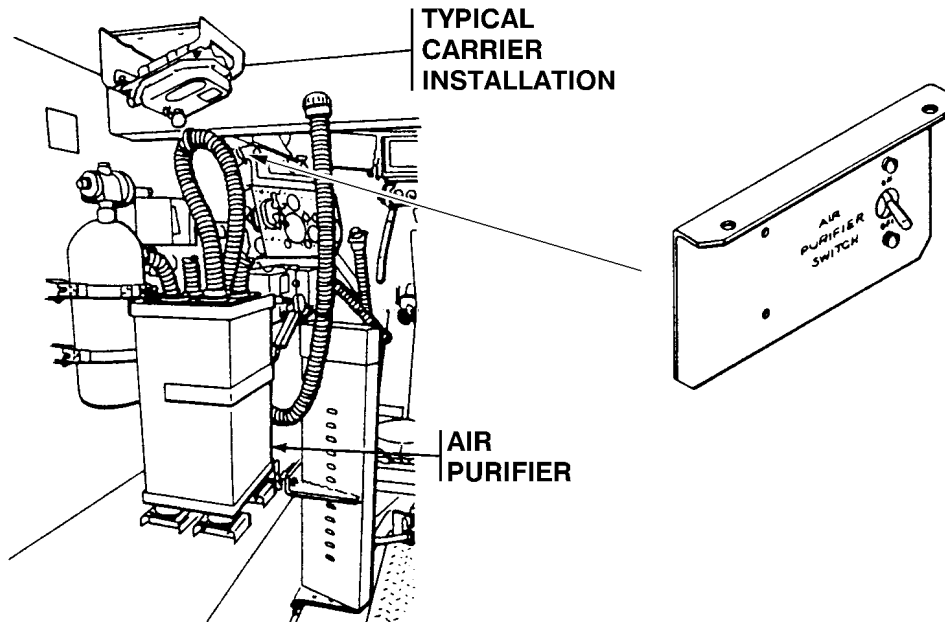

TYPICAL LITTER KIT
INSTALLATION
(M113A3 ONLY)

CAPSTAN AND ANCHOR KITS — M1059A3. Provide a system to pull carriers out of mud, soft dirt, or swampy areas. Act as self-recovery system for the personnel carrier. The Capstan Kit has two drums that attach to the final drives. The Anchor Kit anchors are placed in the ground, then attached to nylon ropes which are wound onto the capstan drums to pull the carrier free. When not in use, the kits are stowed on the top deck and on the left side of the carrier.

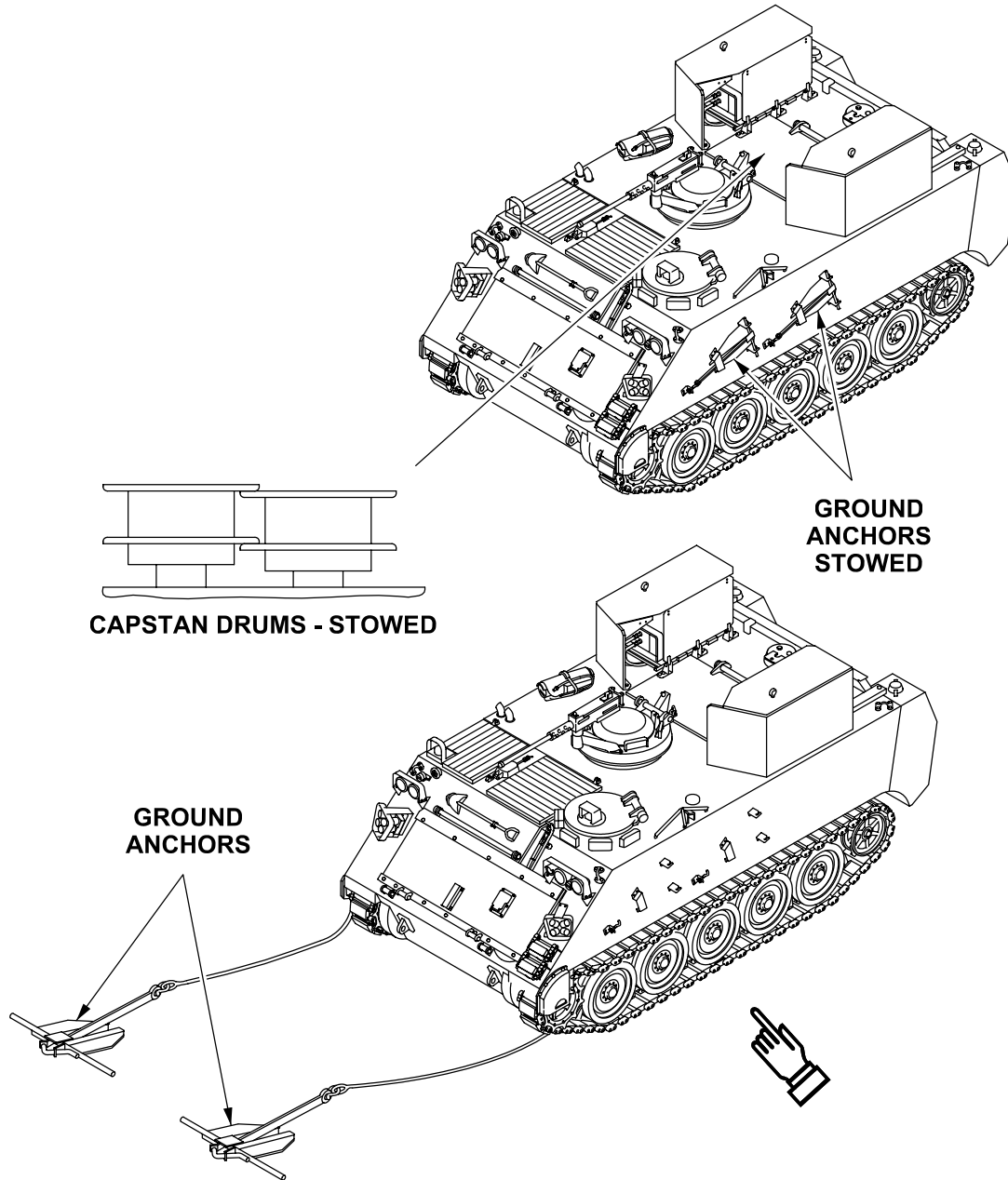

SMOKE GRENADE LAUNCHER — M113A3, M1059A3, AND M58. This kit allows installation of two smoke grenade launchers on the front of the carrier below the headlights. The smoke grenade launchers enable the carrier to generate a smoke screen to conceal the carrier from enemy observation. Each launcher contains a discharger with four launch tubes that hold one grenade each. The arming firing unit (control box) is mounted on the firewall in the crew compartment.

NOTE

The M113A3 carrier is shown.

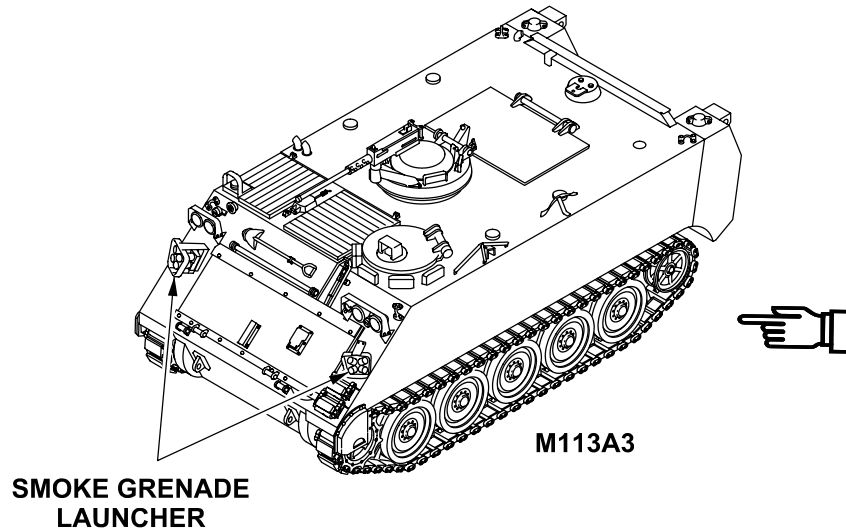

TOW PINTLE EXTENDER KIT — M113A3. This kit reduces contact between the M113A3's external fuel tanks and the trailer frame when the carrier is used to tow M105 or M200 trailers.

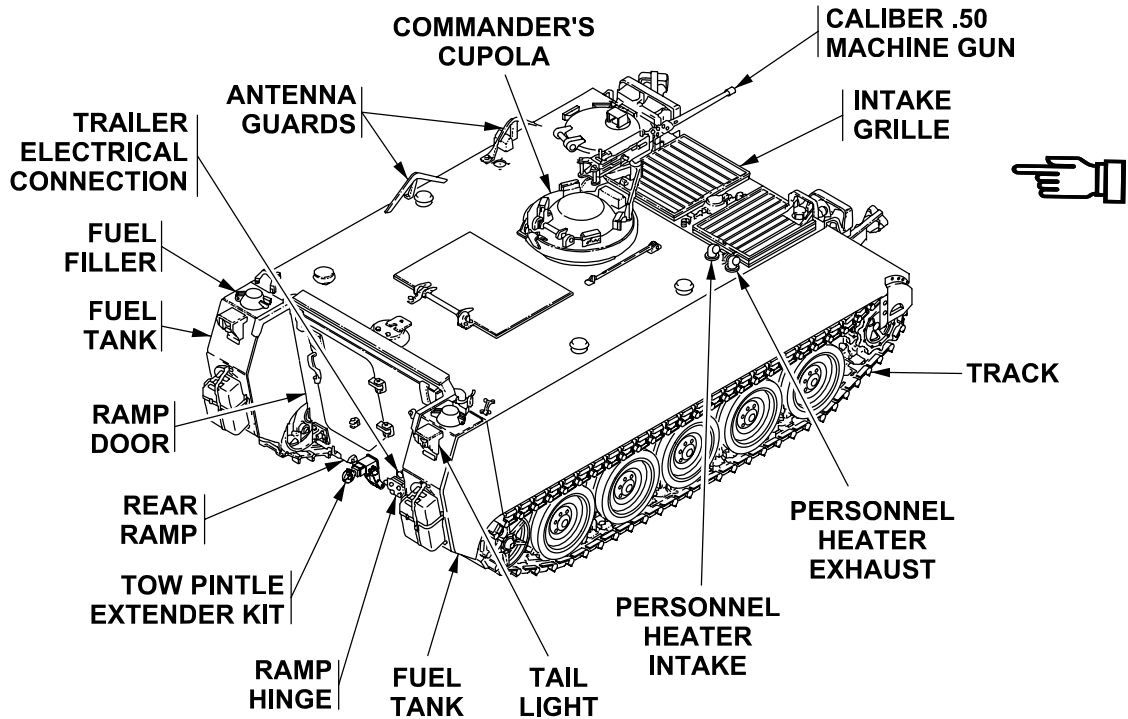

MORTAR FIRE CONTROL SYSTEM (MFCS), M95

Commander's Interface (a) — M1064A3 Only.

- Manages information flow between the gun and FDC.
- Provides interface between other MFCS components and the radios.
- Computes technical fire control solution for weapons operations.
- Provides text and graphics, using a Windows-style interface system.

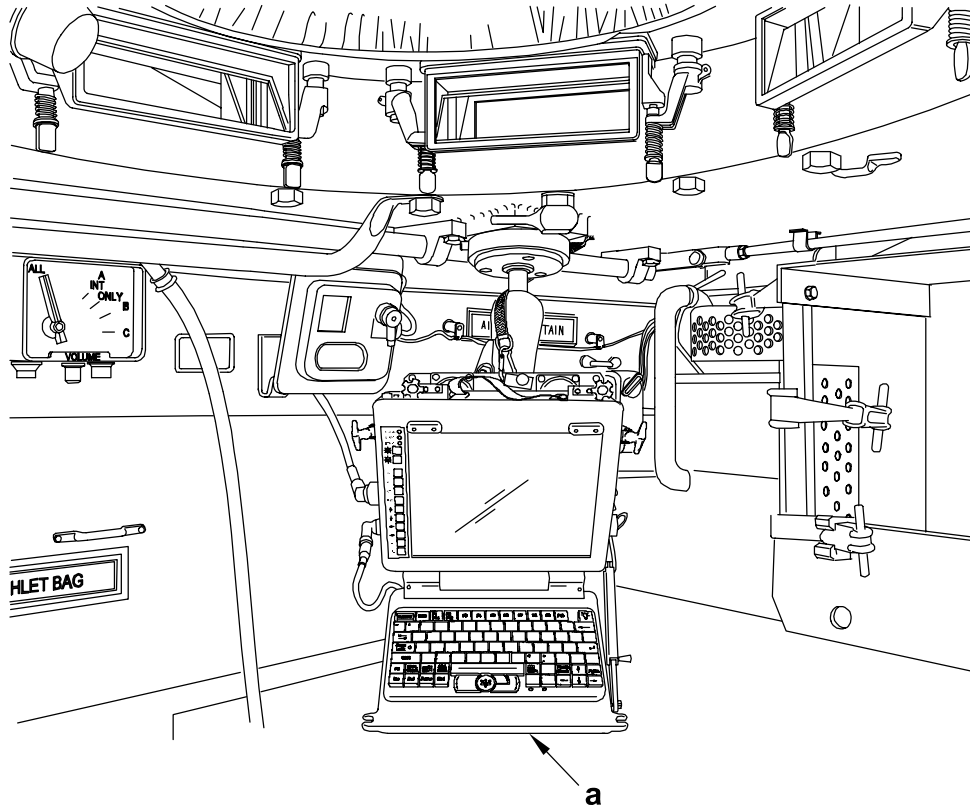

Power Distribution Assembly (b) — M1064A3 Only.

Accepts vehicle direct current (DC) and alternating current (AC) power. See TM 9-1220-248-10 for connections. Filters vehicle power through a DC to DC power system that isolates MFCS components from fluctuations in vehicle power.

Provides protection against reverse polarity and power surges to MFCS components. Each toggle switch acts as a circuit breaker. To reset tripped circuit, move toggle switch to OFF/ON position.

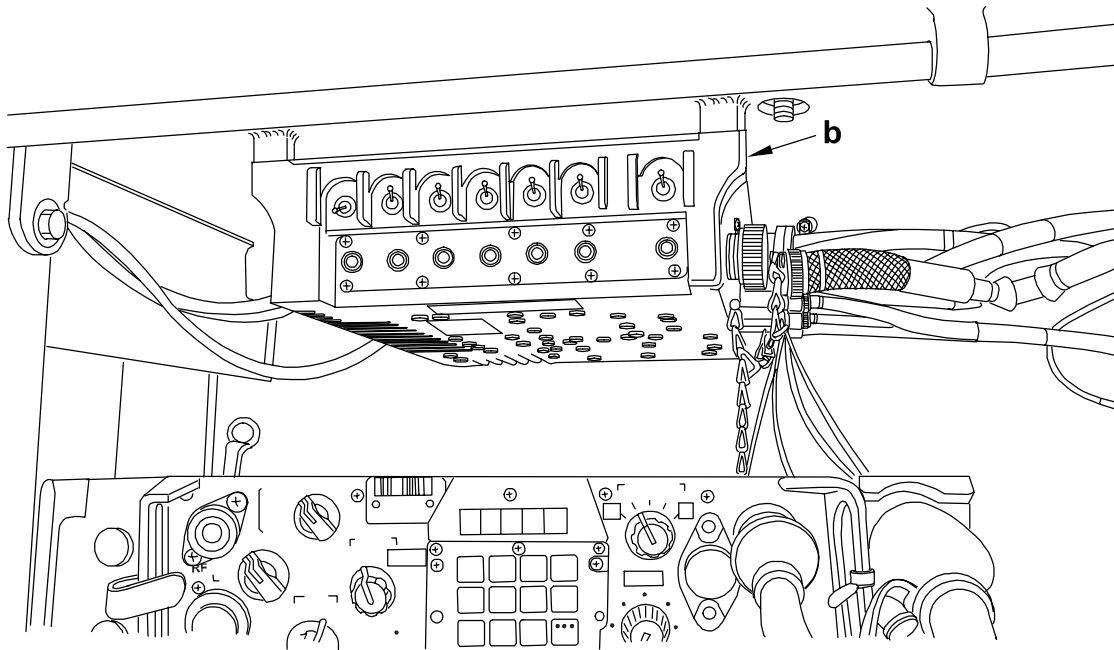

Gunner's Display (c) — M1064A3 Only.

Provides information necessary for the gunner to aim and fire the M121 mortar.
 Receives deflection and elevation orders.
 Provides Check Fire and Call for Fire capability.

Pointing Device (d) — M1064A3 Only.

Aligns M121 mortar and maintains alignment with accuracy within 3 mils azimuth and 1 mil elevation in all conditions.
 Provides pointing and position performance at operational range of 80° South to 84° North latitude.

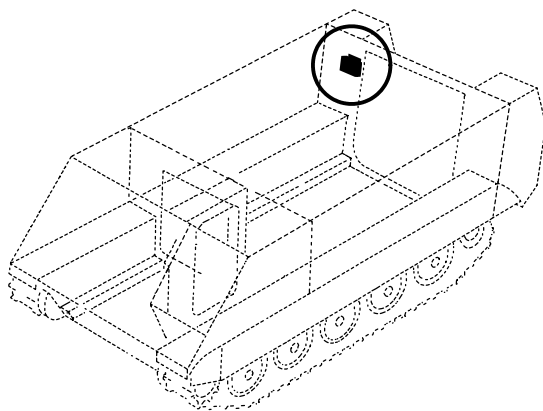
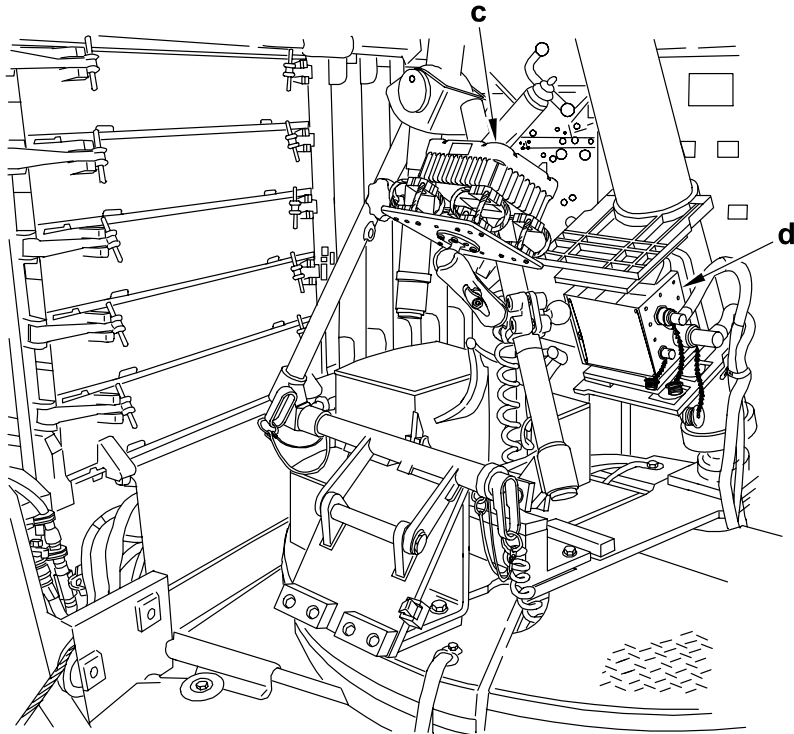

ALTERNATE LOCATION

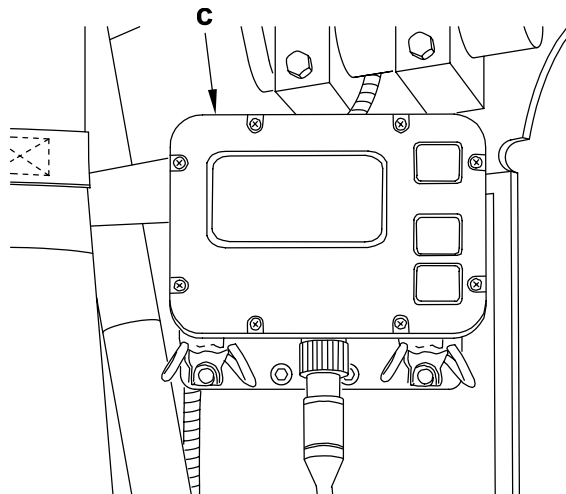

Driver's Display (e) — M1064A3 Only.

Provides driver with information necessary to orient vehicle during emplacement and to assist in driving to the next commanded coordinates.

Provides steering directions and compass orientation in graphical form.

Provides distance and heading information in numeric form.

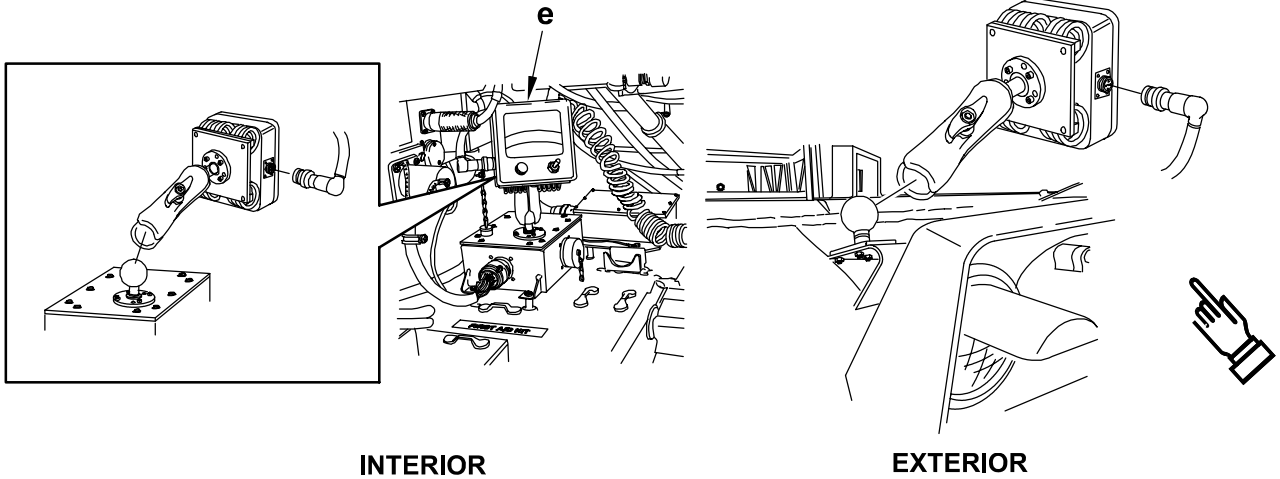

INTERIOR

EXTERIOR

Vehicle Motion Sensor (f) — M1064A3 Only.

Attached in-line between the prime mover and the odometer.

Provides pointing device with velocity data to damp the vertical position error to improve location accuracy.

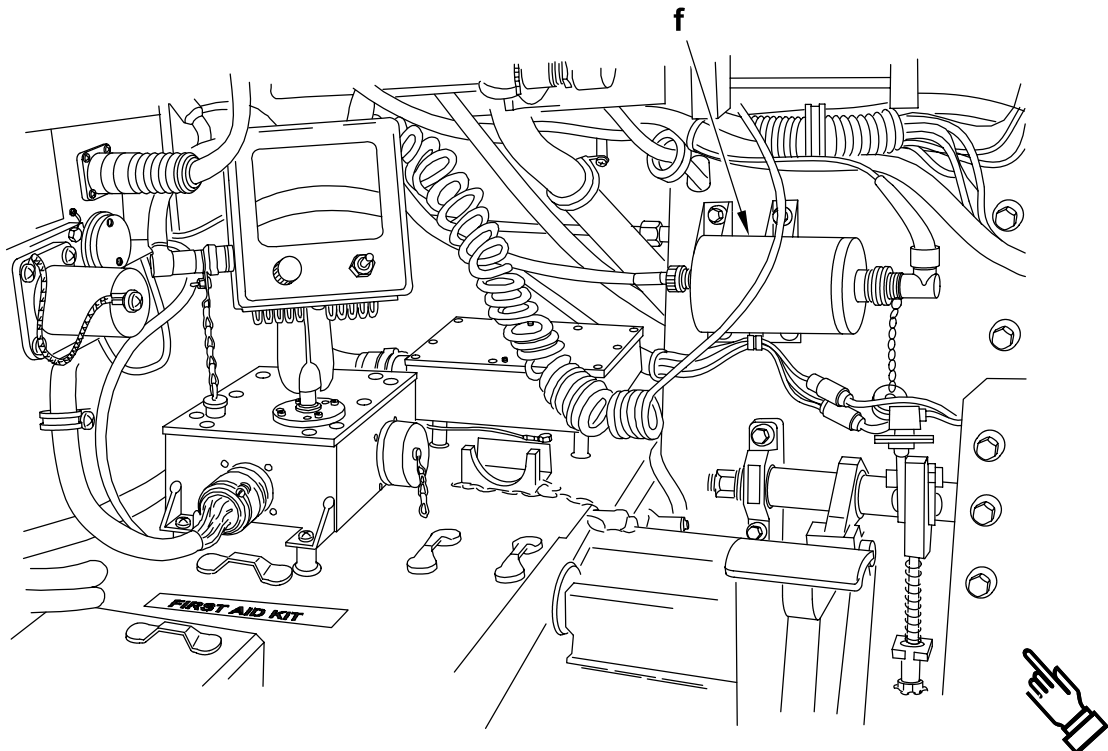

Commander's Interface (g) — M577A3 Only

NOTE

Components are illustrated in approximate locations. System locations may vary according to configuration of particular vehicle.

- Manages information flow between the gun, FDC, and Battalion.
- Provides interface between other MFCS components and the radios.
- Computes technical fire control solution for weapons operations.
- Provides text and graphics, using a Windows-style interface system.

Power Distribution Assembly (h) — M577A3 Only

- Accepts vehicle direct current (DC) and alternating current (AC) power. See TM 9-1220-249-10 for connections.
- Filters vehicle power through a DC to DC power system that isolates MFCS components from fluctuations in vehicle power.
- Provides protection against reverse polarity and power surges to MFCS components. Each toggle switch acts as a circuit breaker. To reset tripped circuit, move toggle switch to OFF/ON position.

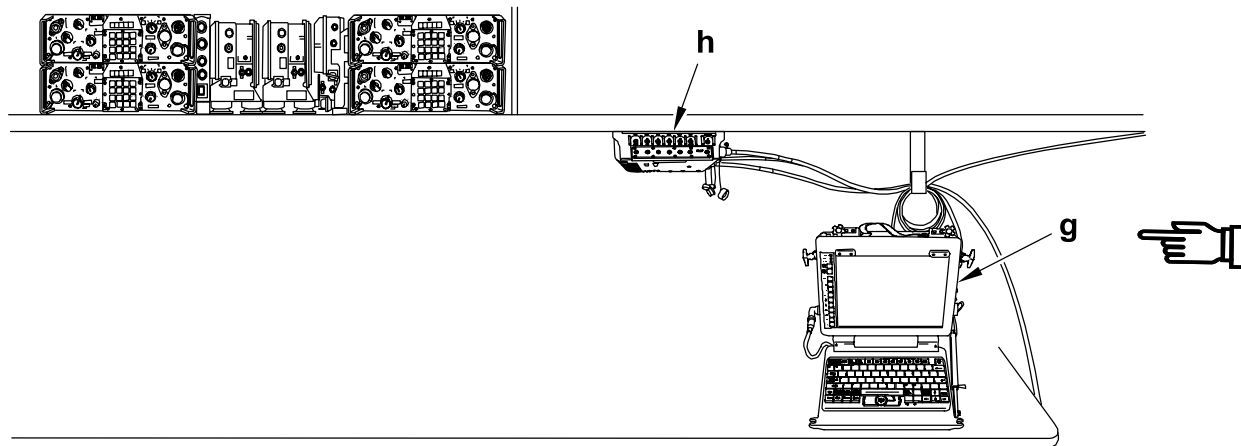

DIFFERENCES BETWEEN CARRIERS

The following table lists the major differences between carriers.

Table 1. DIFFERENCES BETWEEN CARRIERS

Difference	M113A3	M577A3	M1059A3	M1064A3	M1068A3	M58
<u>Carrier Function</u>						
Command Post		X			X	
Mortar				X		
Personnel/Cargo Carrier	X					
Smoke Generator			X			X
<u>Armament</u>						
Machine Gun .50 Caliber	X		X	X		X
Mortar 120-mm				X		
<u>Vision Devices</u>						
Drv's Vision Enhancer						X
Driver's Night Vision	X	X	X	X	X	
Periscope M17	X	X	X	X	X	X
<u>Mission Equipment</u>						
5.0 KW Auxiliary Power Unit		X			X	
4.2 KW Generator Set & Cover		X			X	
Modular Cmd Post Sys					X	
Smoke Generator			X			X
Tent (Covered Extension)		X				
NBC M8A3	X					
MFCS, M95				X		
MFCS, M96		X				
<u>Kits</u>						
Capstan			X			
Cupola Lock	X		X			
Driver's Windshield	X	X	X	X	X	X

Difference	M113A3	M577A3	M1059A3	M1064A3	M1068A3	M58
Engine Coolant Heater	X	X	X	X	X	X
Hospital Litter	X					
Machine Gun Stowage	X					
Marine Recovery			X			
NBC		X	X	X	X	X
Personnel Heater	X	X	X	X	X	X
Smoke Grenade Launcher	X		X			X
Tow Pintle Extender	X		X	X		X
Water/Ration Heater	X	X				

Table 2. GENERAL

Crew (including driver):

M113A3	2 plus 11 Troops
M577A3	5
M1059A3	3
M1064A3	4
M1068A3	4
M58	3

Table 3. SIZE

Length:

All carriers except M577A3 and M1068A3	209-3/8 in. (531.83 cm)
M577A3	191 in. (435.14 cm)
M1068A3	202 in. (513.08 cm)

Width:

Widest (overall)	105-3/4 in. (268.61 cm)
Narrowest (track cover off)	100 in. (254 cm)

Height:

To top of machine gun pintle M113A3 and M1064A3	87-1/2 in. (222.25 cm)
To top of antenna guards M577A3 and M1068A3	106-1/2 in. (270.51 cm)
To top of smoke generator M1059A3	100-3/4 in. (255.91 cm)

To top of smoke guard M58	91 in. (231.14 cm)
Clearance above ground	17-1/8 in. (43.48 cm)

Table 4. WEIGHT

With full load (gross):

M113A3	27,200 lb (12,349 kg)
M577A3	26,000 lb (11,804 kg)
M1059A3	26,600 lb (12,076 kg)
M1064A3	28,240 lb (12,821 kg)
M1068A3	27,000 lb (12,258 kg)
M58	27,200 lb (12,349 kg)

Ground pressure (at gross):

M113A3 and M58	8.67 psi (59.8 kPa)
M577A3	8.26 psi (57 kPa)
M1059A3	7.34 psi (50.6 kPa)
M1064A3	14.0 psi (96.5 kPa)
M1068A3	9.38 psi (64.7 kPa)

Bridge weight classification:

Combat loaded	13
Empty	12

Table 5. CENTER OF GRAVITY

Above ground:

M113A3	40-13/16 in. (104.7 cm)
M577A3	43-1/2 in. (110.5 cm)
M1064A3	40 in. (102 cm)
M1059A3	40-13/16 in. (104.7 cm)
M1068A3	43-5/8 in. (110.8 cm)
M58	39-35/64 in. (100.5 cm)

Distance behind center of sprockets:

M113A3	95-5/16 in. (242.1 cm)
M577A3	79-1/4 in. (201.3 cm)
M1059A3	95-13/32 in. (242.3 cm)
M1064A3	85-3/4 in. (217.8 cm)
M1068A3	78-7/8 in. (200.3 cm)
M58	83-35/64 in. (212.2 cm)

Table 6. PERFORMANCE (LAND)

Fastest forward speed	40 mph (65.5 kph)
Fastest reverse speed	6 mph (9.7 kph)
Number of road wheels	5 pairs per side
Cruising range at 25 mph average:	
M113A3, M1059A3, M1064A3, and M58	300 m (480 km)
M577A3 and M1068A3	425 m (680 km)
Steepest grade	60 percent
Steepest side slope	30 percent
Highest wall climb	2 ft. (0.7 m)
Widest trench	5-1/2 ft (1.67 m)
Maximum towed load	14,500 lb (6583 kg)
Track width	21 in. (53.3 cm)

Table 7. PERFORMANCE (WATER)

Fastest forward speed	3.6 mph (5.79 km/h)
Fording depth (all carriers)	40 in. (101.6 cm)

Table 8. ENGINE

Type	6 cylinder, V-type turbocharged, 2 cycle diesel
Horsepower	275 at 2800 RPM
Idle speed	650-700 RPM
Maximum governed speed:	
Full load	2800 RPM
No load	2950-3000 RPM
Normal operating temperature range	190° to 230°F (87.8° to 110°C)
Cooling	liquid cooled w/radiator and fan
Lubrication	forced feed
Fuel:	
DF-2 (VV-F-800)	only at temperatures above 32°F (0°C)
DF-1 (VV-F-800)	only at temperatures above -10°F (-23°C)
DF-A (VV-F-800)	any temperature
CITE (MIL-F-46005)	any temperature

Table 9. REFILL CAPACITIES

Coolant	13.3 gal (50.34 liter)
Radiator cap pressure rating	13-18 psi (89.63-124.11 kPa)
Oil:	
Engine	22 qt (20.8 liter)
Transmission	36 qt (34.1 liter)
Final drive (each)	3-1/2 qt (3.3 liter)
Fan gearbox	18 oz (0.53 liter)
Diesel fuel:	
Capacity: M113A3, M1059A3, M1064A3, and M58	95 gal (359.6 liter)
M577A3 and M1068A3	120 gal (456 liter)
Maximum filling rate	50 gpm (189.3 liter/m)
Ramp hydraulic system	2 qt (1.9 liter)

Table 10. M157 SMOKE GENERATOR (M1059A3 ONLY)

Fuel	gasoline (MIL-G-3056)
Capacity	10 gal (36.5 liter)
Consumption	6 gal/h (15 liter/h)
Fog oil	SGF-2 (MIL-F-12070)
Capacity	120 gal (438 liter)
Consumption	60-100 gal/h (113 liter/h)
Operational temperature range	-25° to +140°F (-32° to +60°C)

Table 11. M58 SMOKE OBSCURANT SYSTEM (M58 ONLY)

For Equipment Data, see TM 3-1040-285-10.

Table 12. TRACKS

Track shoes, left (when new)	63
Track shoes, right (when new)	64

Table 13. MFCS - M577A3 Only

Brackets

Commander's Interface Bracket

Length x width x depth	12.0 in. x 16.0 in. x 3.0 in. (30.5 cm x 40.6 cm x 7.6 cm)
------------------------	--

Weight	12.0 lb (5.4 kg)
--------	------------------

CI Cable Bracket

Length x width x depth	8.0 in. x 7.0 in. x 2.0 in. (20.3 cm x 17.8 cm x 5.1 cm)
------------------------	--

Weight	0.4 lb (0.2 kg)
--------	-----------------

Cables

MFCS Cables (4W6, 44W7, and 34W10 or 35W30 and 34W13)

Weight	20.0 lb (9.1 kg)
--------	------------------

AC Cable (34W4)

Weight	0.8 lb (0.3 kg)
--------	-----------------

Mounting Hardware

Weight	6.0 lb (2.7 kg)
--------	-----------------

Table 14. MFCS - M1064A3 Only

Commander's Interface (CI)

Length x width x depth (with keyboard open)	20.0 in. x 13.0 in. x 5.0 in. (50.8 cm x 33.0 cm x 12.7 cm)
---	---

Weight, with two batteries	16.5 lb (7.5 kg)
----------------------------	------------------

Required voltage	18 to 30 Vdc
------------------	--------------

Power in watts	65
----------------	----

Power Distribution Assembly (PDA)

Length x width x depth	13.3 in. x 9.3 in. x 2.8 in. (33.8 cm x 23.6 cm x 7.1 cm)
------------------------	---

Weight	11.9 lb (5.4 kg)
--------	------------------

Required voltage	18 to 30 Vdc
------------------	--------------

	115/220 Vac
--	-------------

Power in watts	35
----------------	----

Gunner's Display (GD)

Length x width x depth	6.5 in x 5.0 in. x 2.5 in. (16.5 cm x 12.7 cm x 6.4 cm)
------------------------	---

Weight	8.0 lb (3.6 kg)
--------	-----------------

Required voltage	18 to 30 Vdc
------------------	--------------

Power in watts	24
----------------	----

Pointing Device (PD)

Length x width x depth	9.5 in x 9.0 in. x 6.0 in. (24.1 cm x 22.9 cm x 15.2 cm)
------------------------	--

EQUIPMENT DESCRIPTION — Continued**0002 00**

Weight	12.8 lb (5.8 kg)
Required voltage	16 to 30 Vdc
Power in watts	28
Driver's Display (DD)	
Length x width x depth	5.0 in x 5.3 in. x 2.4 in. (12.7 cm x 13.5 cm x 6.1 cm)
Weight	2.1 lb (1.0 kg)
Required voltage	16 to 30 Vdc
Power in watts	15
Vehicle Motion Sensor (VMS)	
Length x width x depth	8.0 in x 5.5 in. x 4.0 in. (20.3 cm x 14.0 cm x 10.2 cm)
Weight	3.5 lb (1.6 kg)
Required voltage	5 Vdc
Power in watts	2.5
Auxiliary Devices	
Precision Lightweight GPS Receiver (PLGR)	
Length x width x depth	9.5 in x 6.4 in. x 2.6 in. (24.1 cm x 16.3 cm x 6.6 cm)
Weight	2.2 lb (1.0 kg)
Required voltage	9 to 32 Vdc
Power in watts	4
PLGR Antenna	
Length x width x depth	3.0 in x 3.0 in. x 0.5 in. (7.6 cm x 7.6 cm x 1.3 cm)
Weight	0.3 lb (0.1 kg)
PLGR Antenna Plate	
Length x width x depth	9.0 in x 6.0 in. x 1.0 in. (22.9 cm x 15.2 cm x 2.5 cm)
Weight	2.6 lb (1.2 kg)
Brackets	
Commander's Interface Brackets	
Length x width x depth	12.0 in x 16.0 in. x 3.0 in. (30.5 cm x 40.6 cm x 7.6 cm)
Weight	12.0 lb (5.4 kg)
Power Distribution Assembly Welded Standoffs	
Length x width x depth	1.0 in x 1.0 in. x 1.0 in. (2.5 cm x 2.5 cm x 2.5 cm)
Weight	0.1 lb (0.1 kg)
Pointing Device Mounting Assembly	
Length x width x depth	13.8 in x 13.5 in. x 10.0 in. (35.1 cm x 34.3 cm x 25.4 cm)
Weight	24.8 lb (11.2 kg)

EQUIPMENT DESCRIPTION — Continued

0002 00

Gunner's Display Bracket	
Length x width x depth	9.0 in x 6.0 in. x 3.0 in. (22.9 cm x 15.2 cm x 7.6 cm)
Weight	4.5 lb (2.0 kg)
Driver's Display Bracket	
Length x width x depth	6.0 in x 4.5 in. x 2.0 in. (15.2 cm x 11.4 cm x 5.1 cm)
Weight	3.8 lb (1.7 kg)
Driver's Display External Post	
Length x width x depth	3.0 in x 1.5 in. x 1.5 in. (7.6 cm x 3.8 cm x 3.8 cm)
Weight	0.2 lb (0.1 kg)
PLGR Bracket	
Length x width x depth	9.3 in x 4.0 in. x 4.3 in. (23.6 cm x 10.2 cm x 10.9 cm)
Weight	0.8 lb (0.4 kg)
3W5/3W7 "L" Cable Bracket	
Length x width x depth	3.0 in x 2.5 in. x 2.5 in. (7.6 cm x 6.4 cm x 6.4 cm)
Weight	0.1 lb (0.1 kg)
Cables	
MFCS Cables (3W5, 3W6, 3W7, 3W17)	
Weight	20.3 lb (9.2 kg)
PLGR Antenna Cable (34W18)	
Weight	0.2 lb (0.1 kg)
AC Cable (34W4)	
Weight	0.8 lb (0.3 kg)
Miscellaneous Items	
VMS 90° Adapter	
Weight	0.6 lb (0.3 kg)
VMS Mechanical Odometer Cable	
Weight	0.4 lb (0.2 kg)
Mounting Hardware	
Weight	11.0 lb (5.0 kg)
Travel Lock Adapter	
Length x width x depth	16.0 in x 6.0 in. x 6.0 in. (40.6 cm x 15.2 cm x 15.2 cm)
Weight	15.0 lb (6.8 kg)

THEORY OF OPERATION

0003 00**HULL****STEERING AND BRAKING SYSTEM**

The steering and braking systems are an integral part of the crossdrive transmission. The main controls are located in the driver's compartment. Center the steering wheel and set the transmission controller to the SL (steering lock) position whenever the carrier is being started, idling, or shutdown. When the steering wheel is centered and locked, the STEERING LOCKED indicator will light. If the steering wheel is not centered and locked, the carrier will turn (pivot) regardless of the position of the transmission controller. To pivot the carrier, the transmission controller should be set to PV (pivot vehicle) position. The service brakes are operated similar to any automobile. The lower pedal is for normal operations, the upper pedal is used when driving with the seat in the raised position. To operate the parking brake, apply pressure to the service brake and then pull up on parking brake handle.

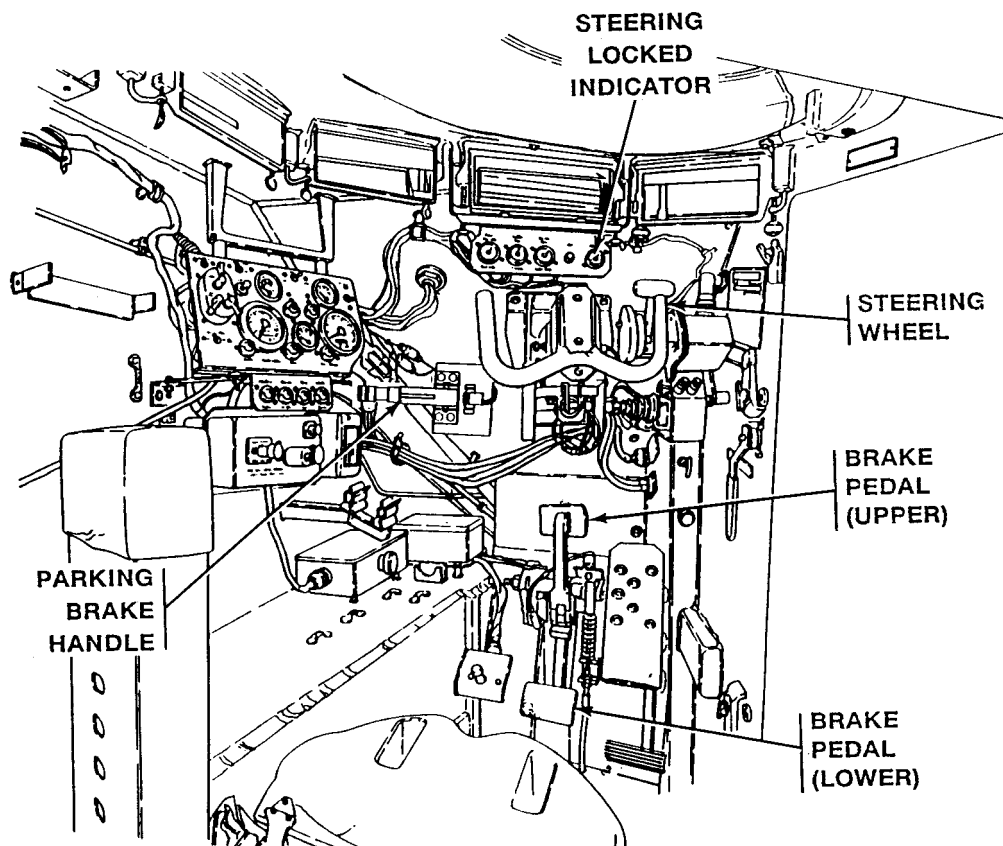

DRIVER'S CONTROLS

The engine, transmission, steering system, and braking system are driver controlled. Engine startup and shutdown are controlled by electrical signals and mechanical linkages connected to the accelerator pedal, the fuel shutoff cable, and the hand throttle cable. Steering and braking are controlled through linkages connected to the transmission. The hand brake is hand controlled.

ENGINE AND DRIVE TRAIN

The engine converts air and diesel fuel into energy. The engine delivers this power to the transmission and variable speed fan drive. The variable speed fan drive drives the alternator and cooling fan. Air for combustion flows through the air cleaner, turbocharger, and the engine. Fuel flows from the fuel tanks to fuel injectors which inject the fuel into the combustion chambers. A drive train transfers power from the engine to the carrier tracks. The drive train consists of the engine, transmission, drive lines, final drive assemblies, and drive sprockets.

COOLING SYSTEM

The engine and transmission generate heat during normal operation. The cooling system transfers some of the heat to the outside to maintain a safe operating temperature. A mixture of antifreeze and water is pumped through the cooling system to cool the engine and transmission. The engine cooling system has a capacity of 13.3 gallons (50.3 liters).

HULL ELECTRICAL SYSTEM

The electrical system operates on four wet cell batteries connected in series/parallel arrangement. Electrical power flows from the batteries through the distribution box, cables, subsystems assemblies, and to the hull. The hull is a ground.

RAMP

The ramp is located at the rear of the carrier to permit rapid entry and exit. The ramp is hinged at the bottom and has two locks at the top. The ramp is raised or lowered by a hydraulic system. This system consists of a pump attached to the engine, a single action cylinder, and a fluid reservoir.

The M58 has a direct vision port in the ramp door.

NBC SYSTEM

NOTE

Other carriers use the same parts but in different locations. Also, kits are added as required. The quantity of orifice connectors is dependent on quantity of crew for each vehicle.

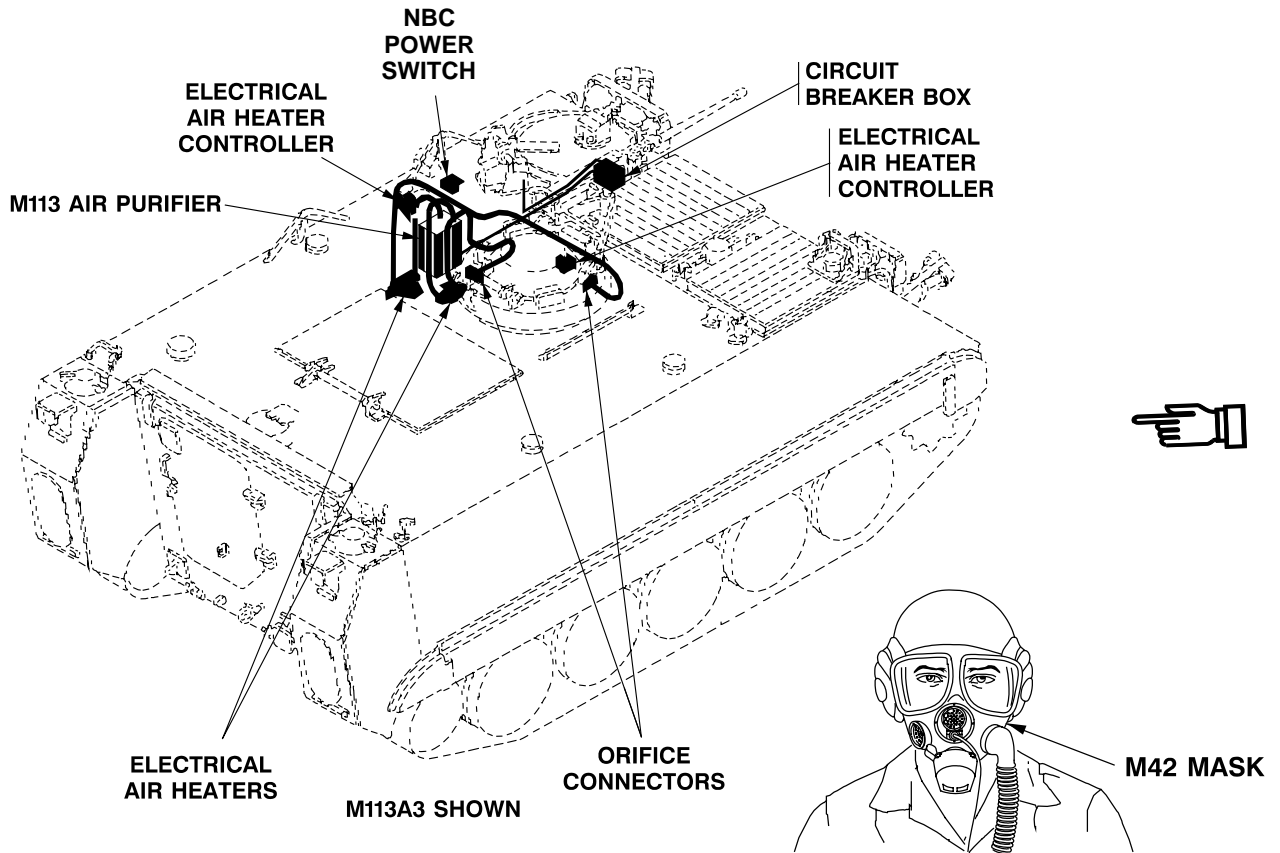

NBC POWER SWITCH turns on blower that draws contaminated air into the system.

M1A1-19 PRECLEANER AND PARTICULATE FILTER remove dust and chemical/biological particles.

GAS FILTERS remove chemical agent gases (M577A3 and M106A3 only).

ELECTRICAL AIR HEATERS allow the individual to electrically heat purified air entering his mask.

ORIFICE CONNECTORS are connectors for masks that also control air flow and closes, when not in use, to keep out dirt.

M42 MASK connects to orifice and is worn by crewmembers.

CIRCUIT BREAKER BOX provides electrical power to the NBC system.

GENERATOR

The generator provides electrical power for all electrical loads and charging the battery. The generator is driven by a drive pulley located on the engine.

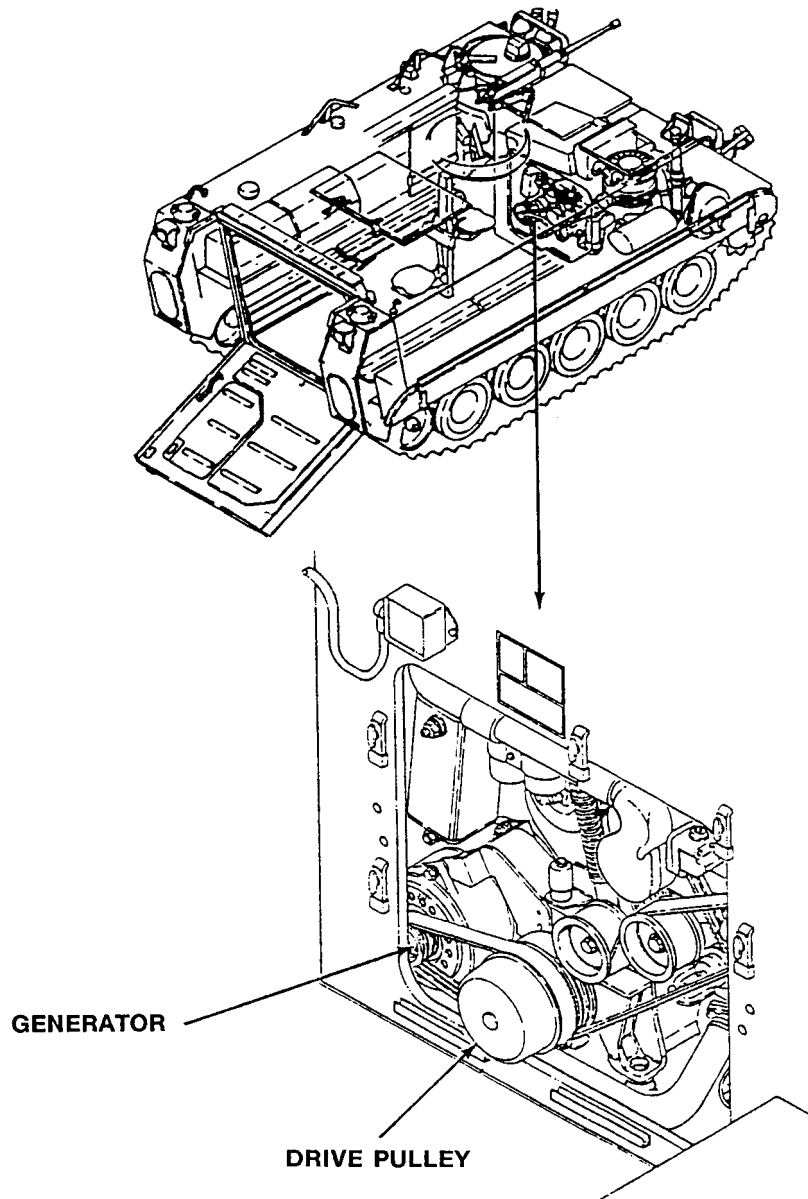

MASTER SWITCH PANEL

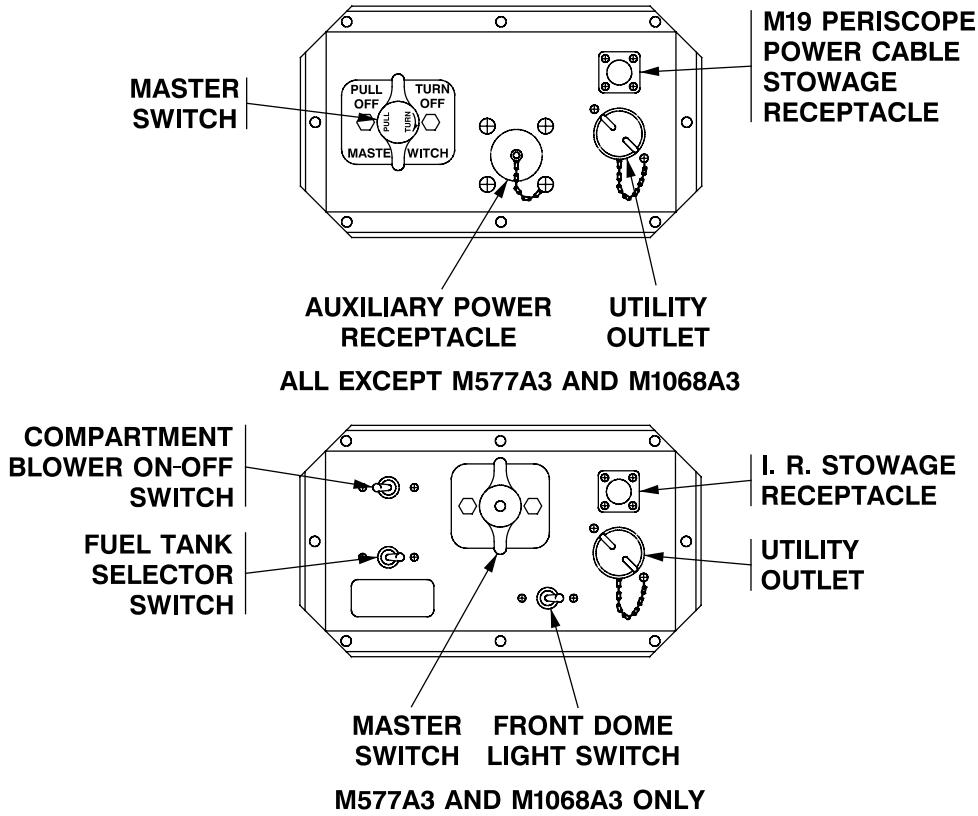

MASTER SWITCH allows electrical power to flow from the batteries through the distribution box, cables, subsystems assemblies, and to the hull.

AUXILIARY POWER RECEPTACLE is used with a slave cable to start carrier engine using an outside power source.

AN/VVS-2 DRIVER'S NIGHT VISION POWER CABLE STORAGE RECEPTACLE is used to stow DNV periscope power cable when driver's night vision is not in use.

UTILITY OUTLET provides power for 24-volt accessories.

COMPARTMENT BLOWER SWITCH (M577A3 and M1068A3 ONLY) controls the compartment blower.

FUEL TANK SELECTOR SWITCH (M577A3 and M1068A3 ONLY) when moved left or right reads quantity of fuel in selected tank.

FRONT DOME LIGHT SWITCH (M577A3 and M1068A3 ONLY) controls the dome lights.

HULL ELECTRICAL SYSTEM

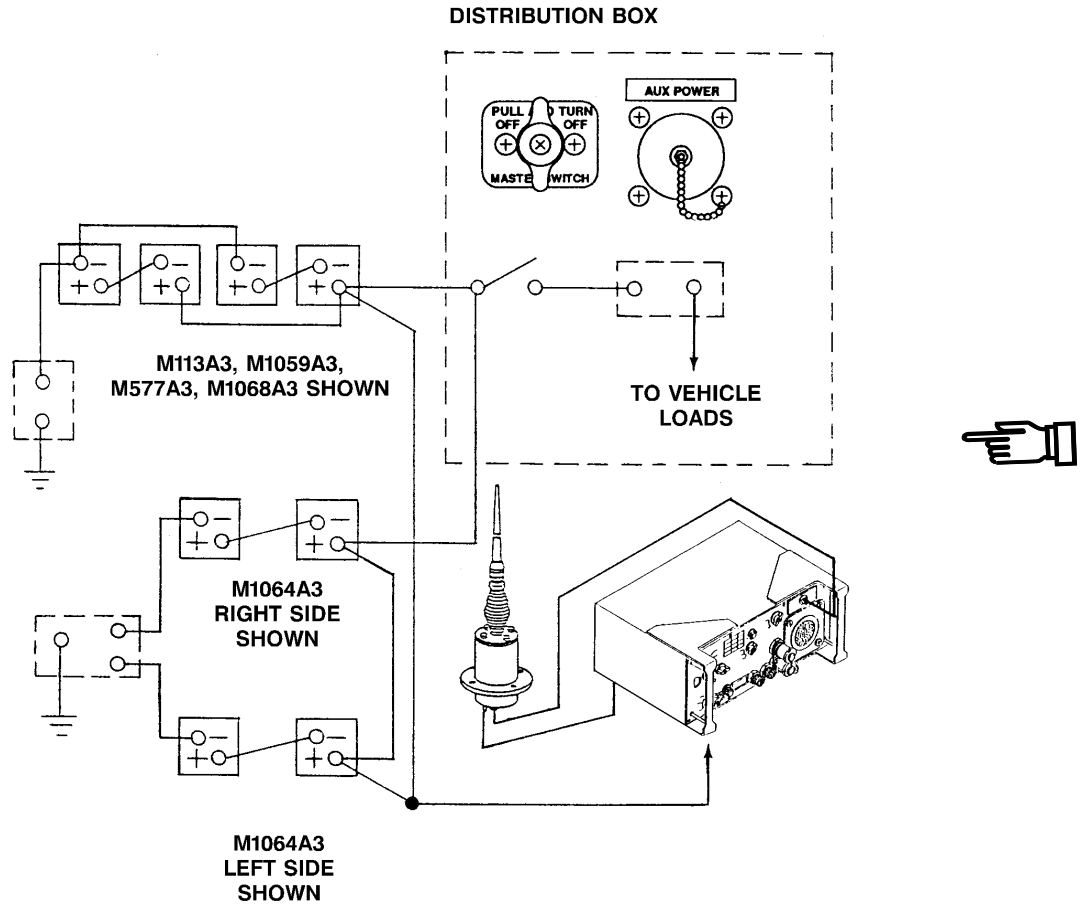

CHAPTER 2
OPERATOR INSTRUCTIONS

WORK PACKAGE INDEX

<u>Title</u>	<u>Sequence No.</u>
DESCRIPTION AND USE OF OPERATOR'S CONTROLS AND INDICATORS.....	.0004 00
OPEN/CLOSE RAMP ACCESS DOOR.....	.0005 00
OPEN/CLOSE DRIVER'S HATCH COVER (M113A3, M1059A3, M1064A3, AND M58 ONLY).....	.0006 00
DELETED.....	.0007 00
OPEN/CLOSE CARGO HATCH COVER (M113A3 AND M1059A3 ONLY).....	.0008 00
OPEN/CLOSE COMMANDER'S HATCH COVER (M113A3, M1059A3, M1064A3, AND M58 ONLY).....	.0009 00
OPERATE COMMANDER'S CUPOLA (M113A3, M1059A3, M1064A3, AND M58 ONLY).....	.0010 00
OPEN/CLOSE POWER PLANT ACCESS DOOR.....	.0011 00
LOWER/RAISE RAMP.....	.0012 00
ADJUST DRIVER'S SEAT.....	.0013 00
ADJUST DRIVER'S LAP SEAT BELT AND SHOULDER HARNESS.....	.0014 00
ADJUST COMMANDER'S SEAT (M113A3, M1059A3, M1064A3, AND M58 ONLY).....	.0015 00
STOW/UNSTOW COMMANDER'S SEAT (M113A3, M1059A3, M1064A3, AND M58 ONLY).....	.0016 00
STOW/UNSTOW JUMP SEAT (M113A3 AND M1059A3).....	.0017 00
CONNECT CVC HELMET TO INTERCOM CONTROL BOX.....	.0018 00
CONNECT CVC HELMET TO VEHICLE INTERCOMMUNICATIONS SYSTEM (VIS).....	.0019 00
SET/RELEASE PARKING BRAKE.....	.0020 00
START ENGINE.....	.0021 00
START ENGINE WITH OUTSIDE POWER SOURCE.....	.0022 00
DRIVE CARRIER.....	.0023 00
STOP ENGINE.....	.0024 00
FUEL CARRIER.....	.0025 00
REFUEL CARRIER (M577A3 AND M1068A3 ONLY).....	.0026 00
INSTALL/REMOVE WINDSHIELD.....	.0027 00
OPERATE PERSONNEL HEATER.....	.0028 00
OPERATE PERSONNEL COMPARTMENT VENTILATOR.....	.0029 00
OPERATE CARRIER LIGHTS.....	.0030 00
OPERATE FIXED FIRE EXTINGUISHER SYSTEM.....	.0031 00
OPERATE PORTABLE FIRE EXTINGUISHER.....	.0032 00
INSTALL/REMOVE M17 PERISCOPES.....	.0033 00
INSTALL/REMOVE AN/VVS-2(V)1A DRIVER'S NIGHT VISION (ALL EXCEPT M58).....	.0034 00
OPERATE AN/VVS-2(V)1A DRIVER'S NIGHT VISION (ALL EXCEPT M58).....	.0035 00
INSTALL/REMOVE AN/VAS-5 DRIVER'S VISION ENHANCER (DVE) (M58 ONLY).....	.0035 01
OPERATE AN/VAS-5 DRIVER'S VISION ENHANCER (DVE) (M58 ONLY).....	.0035 02

CHAPTER 2
OPERATOR INSTRUCTIONS

WORK PACKAGE INDEX (Continued)

<u>Title</u>	<u>Sequence No.</u>
REPLACE DRIVER'S/COMMANDER'S DISPLAY (DVE) (M58 ONLY).....	0035 03
INSTALL/REMOVE MACHINE GUN (M2, .50 CAL) (M113A3, M1059A3, M1064A3, AND M58 ONLY).....	0036 00
SECURE MACHINE GUN (M2, .50 Cal) FOR TRAVEL (M113A3, M1059A3, M1064A3, AND M58 ONLY).....	0037 00
SECURE MACHINE GUN (M2, .50 Cal) TO ARMOR SHIELD FOR TRAVEL (M113A3, M1059A3, AND M1064A3 ONLY).....	0038 00
LOWER/STOW TRIM VANE.....	0039 00
REMOVE/INSTALL POWER PLANT ACCESS PANELS.....	0040 00
POSITIONING SPALL LINERS FOR ACCESS TO EQUIPMENT (M113A3 ONLY).....	0041 00
BLOCK/UNBLOCK CARRIER TRACKS.....	0042 00
INSTALL/REMOVE WATER/RATION HEATER.....	0043 00
OPERATE WATER/RATION HEATER.....	0044 00
OPERATE 5.0 KW AUXILIARY POWER UNIT (APU) (M577A3 AND M1068A3 ONLY).....	0045 00
OPEN/CLOSE COMMANDER'S HATCH (M577A3 AND M1068A3 ONLY).....	0046 00
OPERATE COMMANDER'S PLATFORM (M577A3 AND M1068A3 ONLY).....	0047 00
OPEN/CLOSE DRIVER'S HATCH (M577A3 AND M1068A3 ONLY).....	0048 00
RAISE/LOWER DROP LEAF TABLES (M577A3 ONLY).....	0049 00
INSTALL/REMOVE DRIVER'S BLACKOUT CURTAIN (M577A3 AND M1068A3 ONLY).....	0050 00
UNSTOW/STOW MAP TABLE AND BOARD (M577A3 AND M1068A3 ONLY).....	0051 00
OPEN/CLOSE MORTAR HATCH COVER (M1064A3 ONLY).....	0052 00
DELETED.....	0053 00
REMOVE/INSTALL 4.2 KW GENERATOR SET (M577A3 AND M1068A3 ONLY).....	0054 00
OPERATE 4.2 KW GENERATOR SET (M577A3 AND M1068A3 ONLY).....	0055 00
SET UP COMMAND POST TENT (COVERED EXTENSION) (M577A3 ONLY).....	0056 00
DISMANTLE/STOW MODULAR COMMAND POST SYSTEM (MCPS) (M1068A3 ONLY).....	0057 00
INSTALL/REMOVE TENT LINER FOR EXTREME COLD WEATHER (M577A3 ONLY).....	0058 00
DISMANTLE/STOW COMMAND POST TENT (COVERED EXTENSION) (M577A3 ONLY).....	0059 00
REFUEL GENERATOR SET (M577A3 AND M1068A3 ONLY).....	0060 00
OPERATE IN EXTREME COLD: BELOW -25° F (-31° C).....	0061 00
OPERATE ENGINE COOLANT HEATER (BELOW -25° F (-31° C)).....	0062 00
DELETED.....	0063 00
FORD WATER UP TO 40 INCHES DEEP.....	0064 00
PERFORM POST-FORDING OPERATIONS.....	0065 00
DELETED.....	0066 00
DELETED.....	0067 00
DELETED.....	0068 00

CHAPTER 2
OPERATOR INSTRUCTIONS

WORK PACKAGE INDEX (Continued)

<u>Title</u>	<u>Sequence No.</u>
DELETED.....	.0069 00
DELETED.....	.0070 00
DELETED.....	.0071 00
DELETED.....	.0072 00
OPERATE CARRIER OVER ROUGH TERRAIN.....	.0073 00
OPERATE CARRIER IN EXTREME HEAT, HUMIDITY, OR SALTY CONDITIONS.....	.0074 00
BYPASS DEFECTIVE TRANSMISSION CONTROLLER.....	.0075 00
SECURING INOPERABLE/UNSAFE RAMP.....	.0076 00
TOWING DISABLED CARRIER0077 00
TOW START DISABLED CARRIER.....	.0078 00
TOWING TRAILER WITH CARRIER.....	.0079 00
OPERATE NBC KIT.....	.0080 00
OPERATE NBC SYSTEM.....	.0081 00
OPERATE SMOKE GRENADE LAUNCHERS (ALL EXCEPT M577A3, M1064A3, AND M1068A3).....	.0082 00
COVER/UNCOVER INTAKE AND EXHAUST GRILLES.....	.0083 00
DELETED.....	.0084 00
DELETED.....	.0085 00
OPERATE GLOW PLUG COLD START SYSTEM (MANUAL OVERRIDE).....	.0086 00
ASSEMBLY AND PREPARATION FOR USE MORTAR FIRE CONTROL SYSTEM (MFCS), M95 ONLY.....	.0086 01

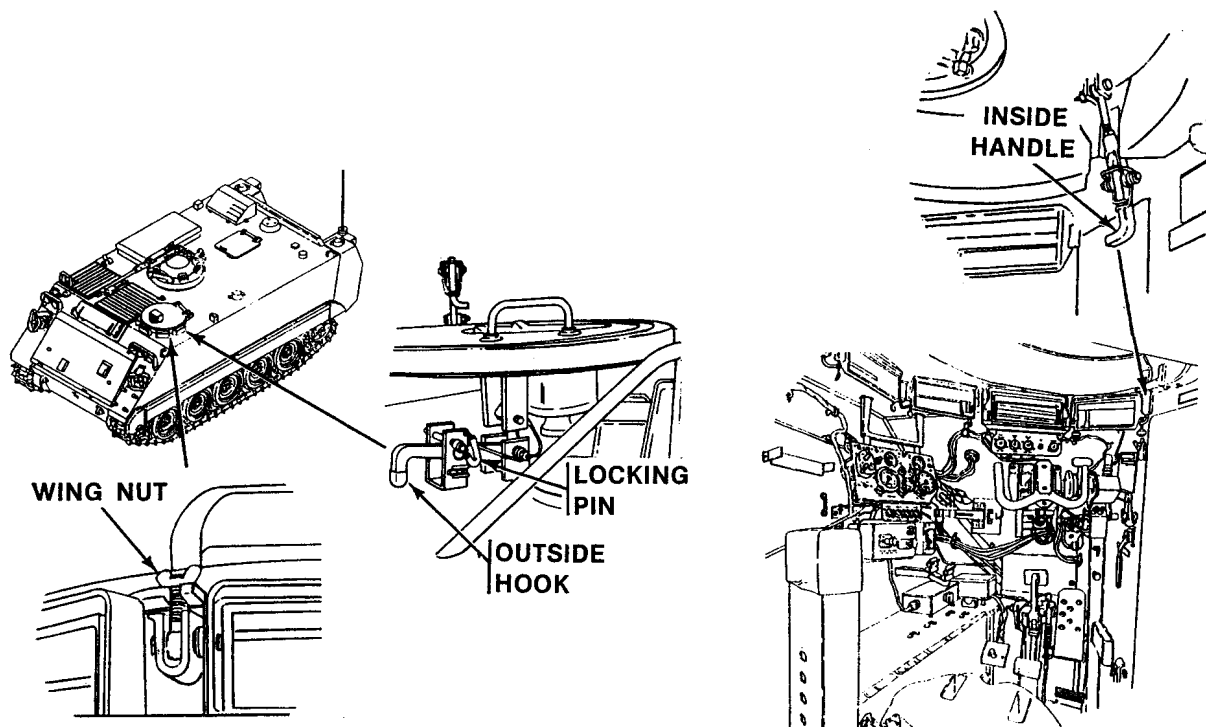

Table 1. DRIVER'S HATCH CONTROLS (M113A3, M1059A3, M1064A3, AND M58 ONLY)

KEY	CONTROL OR INDICATOR	FUNCTION
	OUTSIDE HOOK AND LOCKING PIN	Locks hatch cover in fully open position. Locking pin is provided to secure hook and prevent accidental release of hatch cover.
	INSIDE HANDLE	Locks and unlocks driver's hatch cover from inside the carrier. Driver's hatch cover opens slightly when unlocked.
	WING NUT	Locks and unlocks driver's hatch cover from outside the carrier. Used when carrier is not being operated.

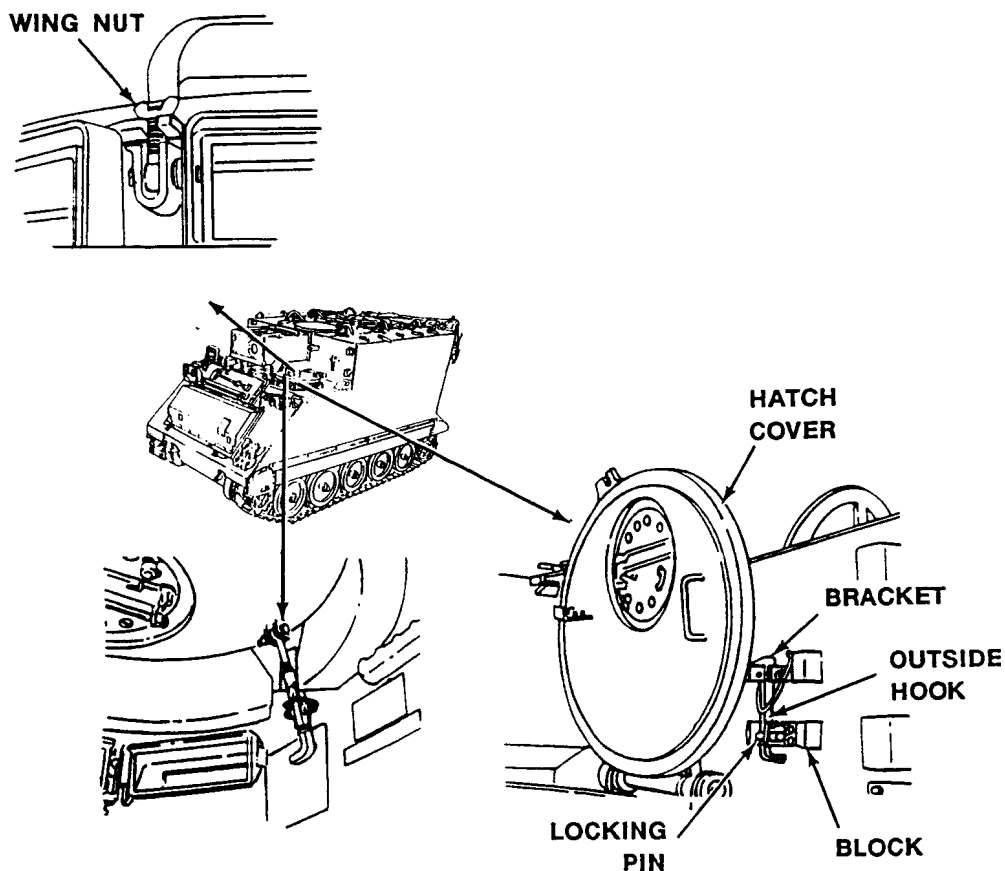

Table 2. DRIVER'S HATCH CONTROLS (M577A3 AND M1068A3 ONLY)

KEY	CONTROL OR INDICATOR	FUNCTION
	OUTSIDE HOOK AND LOCKING PIN	Locks hatch cover in fully open position. Locking pin is provided to secure hook and prevent accidental release of hatch cover.
	WING NUT	Locks and unlocks driver's hatch cover from outside the carrier. Used when carrier is not being operated.

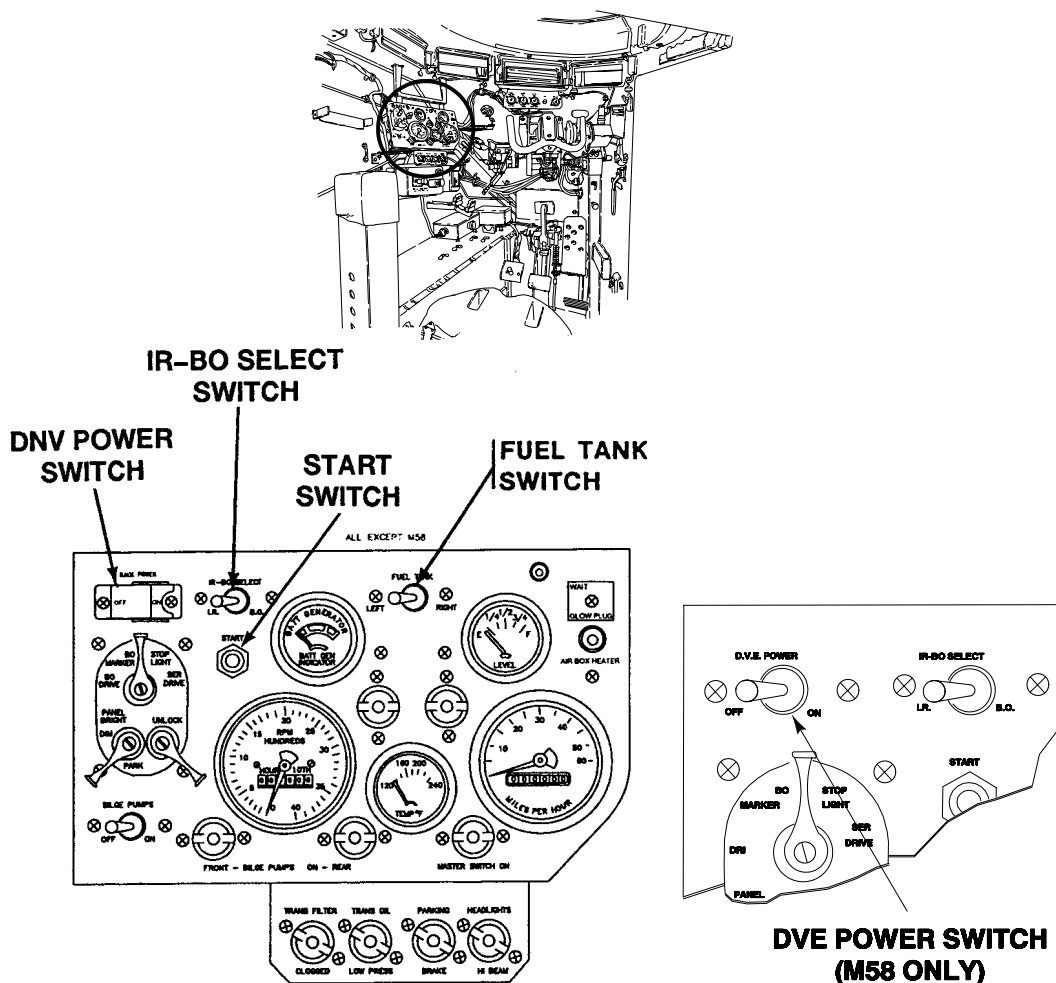
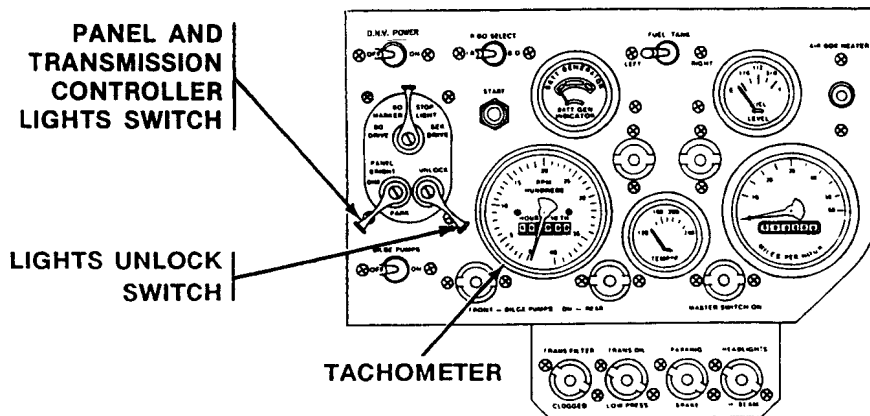
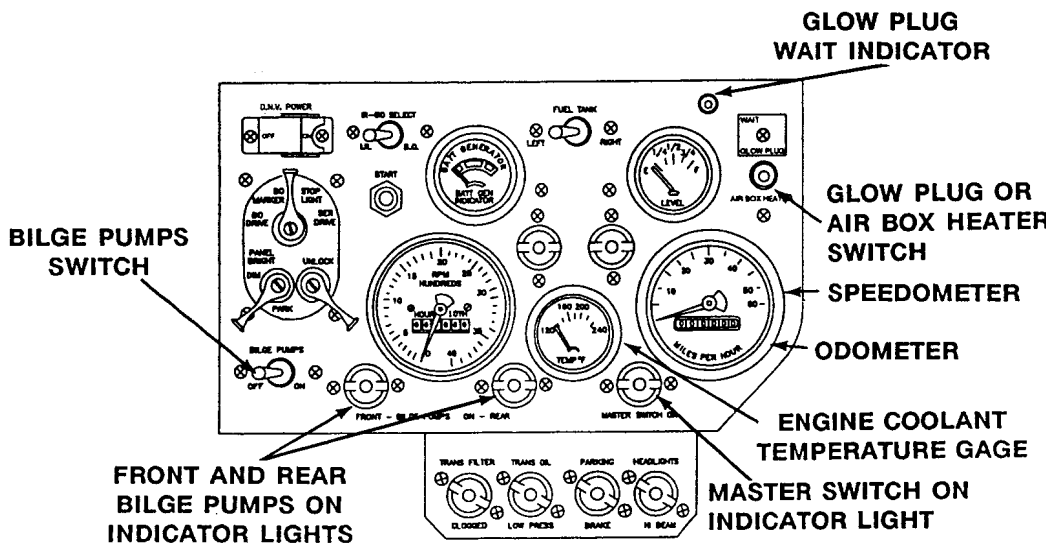

Table 3. DRIVER'S INSTRUMENT PANEL

KEY	CONTROL OR INDICATOR	FUNCTION
	DVE POWER SWITCH (M58 ONLY)	Two position toggle switch to turn power to the DRIVER'S VISION ENHANCER on or off.
	DNV POWER SWITCH (ALL EXCEPT M58)	Two position toggle switch to turn power to the AN/VVS-2 periscope on or off. Late model vehicles have a guard on DNV (driver's night vision) power switch.
	IR-BO SELECT SWITCH	Two position toggle switch to select IR or BO (blackout) mode of lights operation.
	START SWITCH	Engages engine starter.
	FUEL TANK SWITCH	Two position toggle switch allows driver to read fuel level in LEFT and RIGHT external fuel tanks.



KEY	CONTROL OR INDICATOR	FUNCTION
	<p>TACHOMETER</p> <p>LIGHTS UNLOCK SWITCH</p> <p>PANEL AND TRANSMISSION CONTROLLER LIGHTS SWITCH</p>	<p>Indicates engine speed in revolutions per minute (RPM) and accumulated hours of engine operation.</p> <p>Spring-loaded, two-position lever. Must be held in UNLOCK position when setting driving light switch to any position other than BO MARKER. Returns to locking position when released.</p> <p>Four position rotary switch controls panel and transmission controller lights as follows:</p> <p>PANEL BRIGHT - Turns panel and transmission controller lights to bright.</p> <p>DIM - Turns panel and transmission controller lights to dim.</p> <p>OFF - Turns off panel and transmission controller light system.</p> <p>PARK - Turns on stoplight-taillight.</p>



KEY	CONTROL OR INDICATOR	FUNCTION
	AIR BOX HEATER SWITCH	Used while starting engine during cold weather -25°F to +40°F (-31°C to +4°C). Switch is spring loaded to the off position.
	GLOW PLUG SWITCH	Used while starting engine during cold weather -25°F to +40°F (-31°C to +4°C). Switch is spring loaded to the off position.
	SPEEDOMETER	Indicates carrier speed in miles per hour.
	ODOMETER	Indicates total carrier distance traveled in miles.
	MASTER SWITCH ON INDICATOR LIGHT	Light comes on when MASTER SWITCH is ON.
	ENGINE COOLANT TEMPERATURE GAUGE	Indicates engine operating temperature in degrees Fahrenheit.
	FRONT AND REAR BILGE PUMPS ON INDICATOR LIGHTS	Indicator lights come on when BILGE PUMPS switch is moved to ON.
	BILGE PUMPS SWITCH	Turns front and rear bilge pumps ON and OFF.
	GLOW PLUG WAIT INDICATOR	Indicates both glow plug controller operation and 35-second warm-up period.

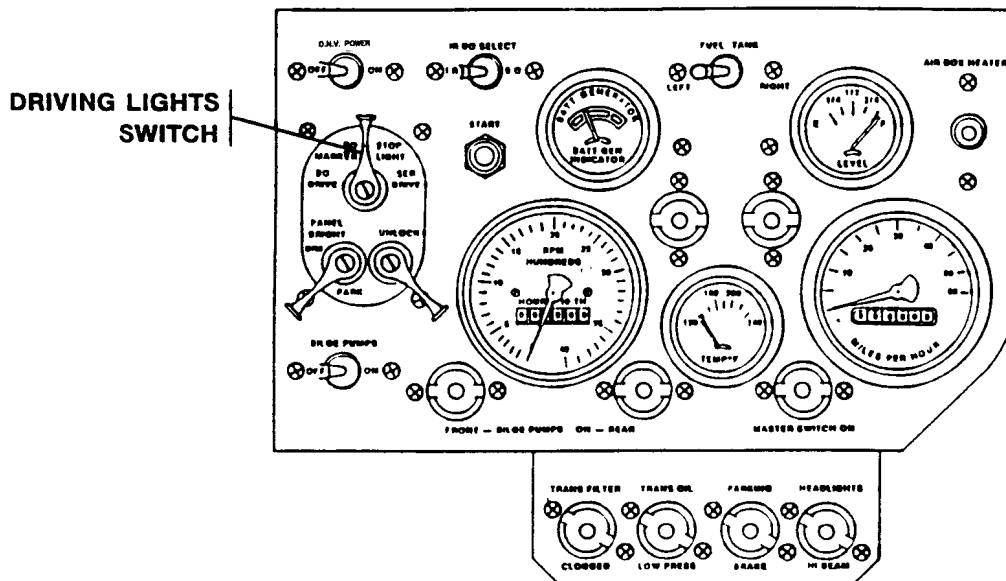

KEY	CONTROL OR INDICATOR	FUNCTION
	DRIVING LIGHTS SWITCH	<p>Five position rotary switch controls outside carrier lights as follows:</p> <p style="text-align: center;">CAUTION</p> <p>Damage can occur to DNV power supply if DNV periscope is not connected.</p> <p>BO DRIVE - with IR-BO SELECT switch in BO, blackout headlight and four blackout marker lights are on. When brakes are applied, blackout stop light will come on. With IR-BO SELECT switch in IR, and DNV POWER switch on, two infrared headlights and four blackout marker lights are on. When brakes are applied, blackout stop light will come on.</p> <p>BO MARKER - Turns on four blackout marker lights. When brakes are applied, blackout stop light will come on.</p> <p>OFF - Turns off all exterior lights.</p> <p>STOPLIGHT - Allows stop light-tail light to function during daytime operation without headlights.</p> <p>SER DRIVE - Turns on headlights and allows stoplight-tail light to function.</p>

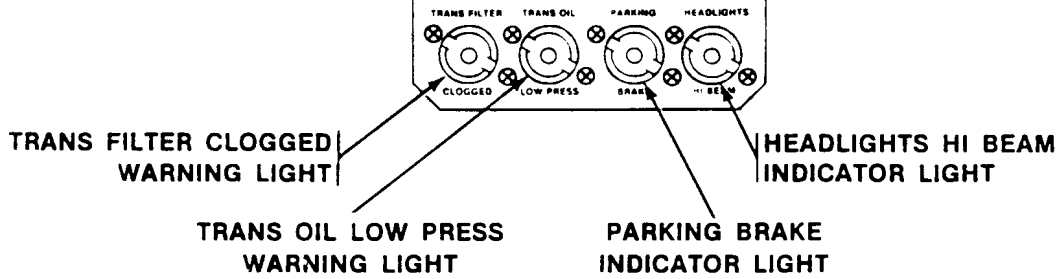
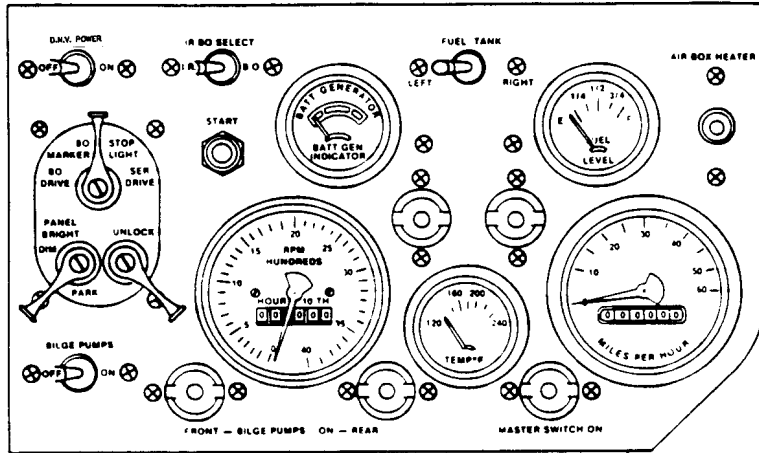

ALL EXCEPT M58

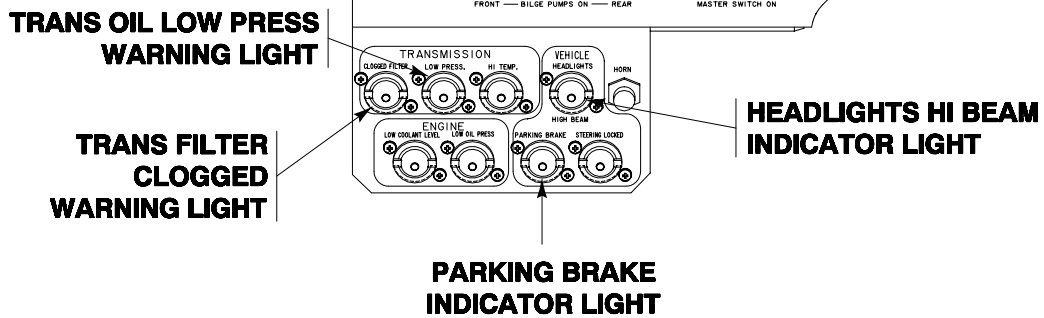
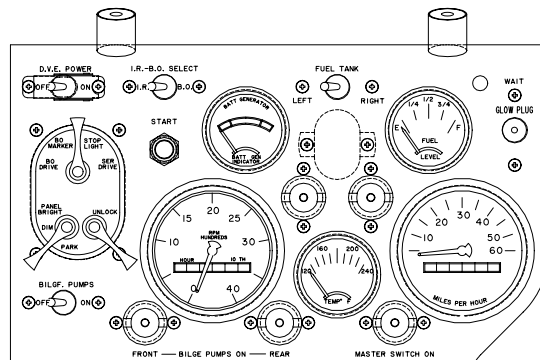

M58 ONLY



DESCRIPTION AND USE OF OPERATOR'S CONTROLS AND INDICATORS — Continued

0004 00

KEY	CONTROL OR INDICATOR	FUNCTION
	TRANS FILTER CLOGGED WARNING LIGHT	Light comes on when transmission filter is clogged and engine is running.
	TRANS OIL LOW PRESS WARNING LIGHT	Light comes on when transmission oil pressure is low.
	PARKING BRAKE INDICATOR LIGHT	Light comes on when parking brake is set.
	HEADLIGHTS HI BEAM INDICATOR LIGHT	Light comes on when headlight high beams are on.

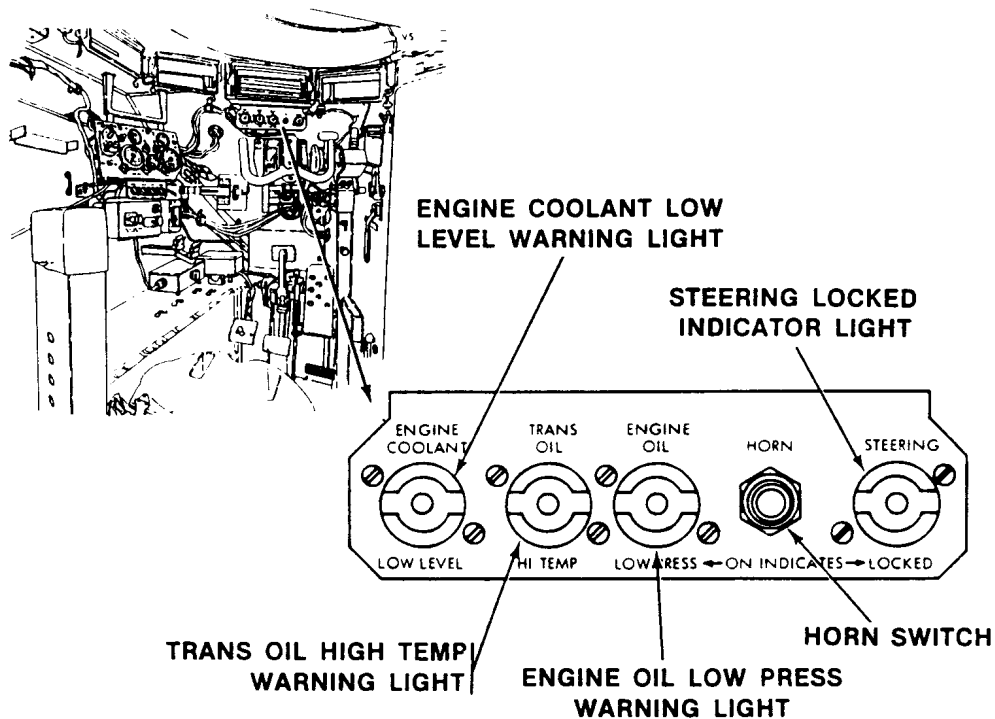

(ALL EXCEPT M58)

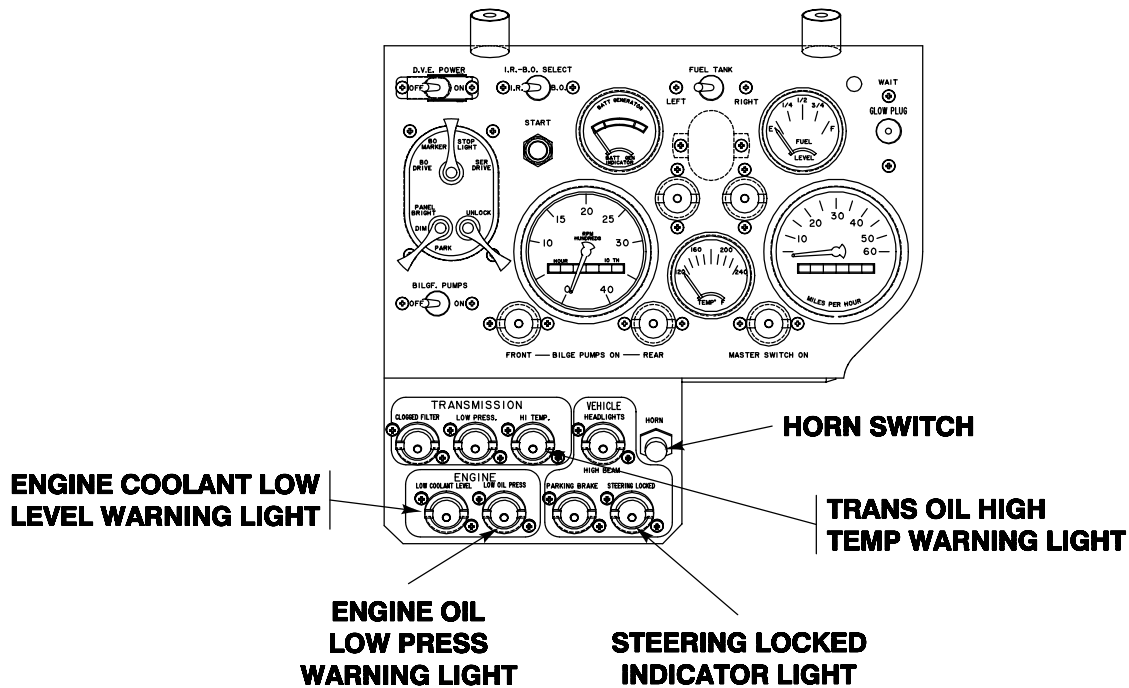

(M58 ONLY)

Table 4. WARNING LIGHT PANEL

KEY	CONTROL OR INDICATOR	FUNCTION
	ENGINE COOLANT LOW LEVEL WARNING LIGHT	Light comes on when coolant level is too low for safe operation.
	TRANS OIL HIGH TEMP WARNING LIGHT	Light comes on when transmission oil temperature is too high for safe operation.
	ENGINE OIL LOW PRESS WARNING LIGHT	Light comes on when oil pressure is too low for safe operation. Light should go off 10 seconds after engine starts.
	HORN SWITCH	Press switch to sound carrier horn.
	STEERING LOCKED INDICATOR LIGHT	Light comes on when steering wheel is locked in center position. To lock steering wheel, center wheel to engage locking pin. Move transmission controller to SL position and place MASTER SWITCH to ON.

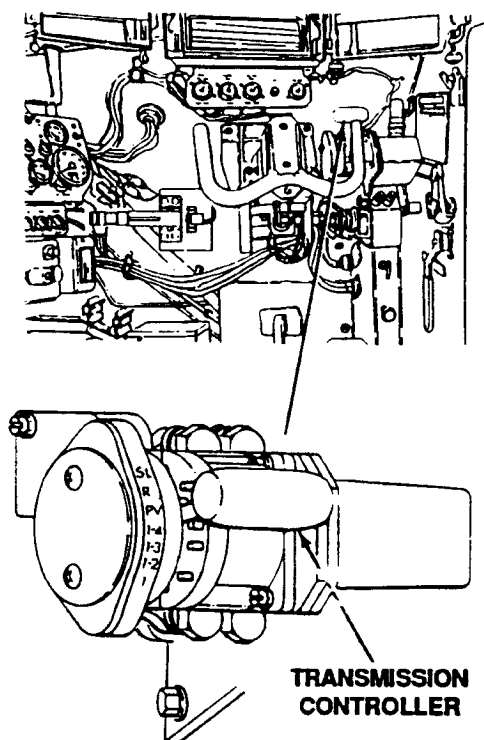

Table 5. ELECTRICAL TRANSMISSION CONTROLLER

KEY	CONTROL OR INDICATOR	FUNCTION
	TRANSMISSION CONTROLLER	<p>Selects driving RANGE of automatic transmission.</p> <p>RANGE 1 - Used when climbing or going down steep grades, and when entering or leaving water. This range provides maximum traction, low speed maneuvering, and engine braking.</p> <p>RANGE 1-2 - Used when climbing or going down medium grades, driving cross country at slow speeds, and while in the water.</p> <p>RANGE 1-3 - Used when climbing or going down slight grades, driving cross country at high speeds, and driving on roads at moderate speeds.</p> <p>RANGE 1-4 - Used to drive carrier in normal forward operation.</p> <p>PV (PIVOT VEHICLE) POSITION - Used to turn carrier on its own center.</p> <p>R (REVERSE) POSITION - Used for backing the carrier on land or in the water.</p> <p>SL (STEERING LOCK) POSITION - Locks steering wheel in center position. Used during starting, idling, and engine shut down.</p>

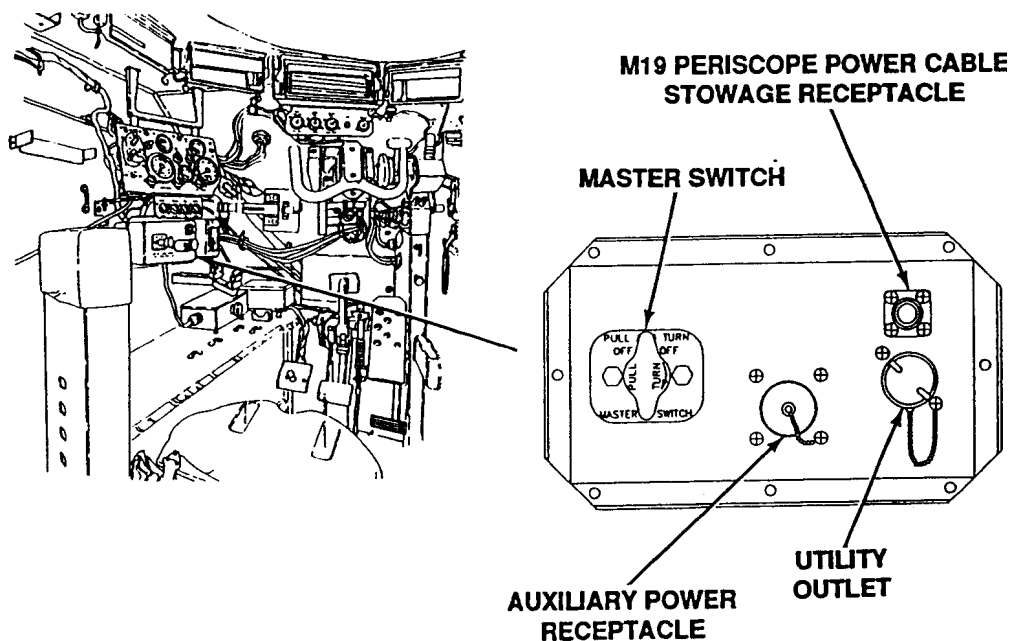

Table 6. MASTER SWITCH PANEL (M113A3, M1059A3, M1064A3, AND M58 ONLY)

KEY	CONTROL OR INDICATOR	FUNCTION
	MASTER SWITCH	Turns carrier electrical power on or off.
	AUXILIARY POWER RECEPTACLE	Used with a slave cable to start carrier engine using an outside power source.
	M19 PERISCOPE POWER CABLE STOWAGE RECEPTACLE	Used to stow M19 periscope power cable when periscope is not in use.
	UTILITY OUTLET	Provides power for 24-volt accessories.

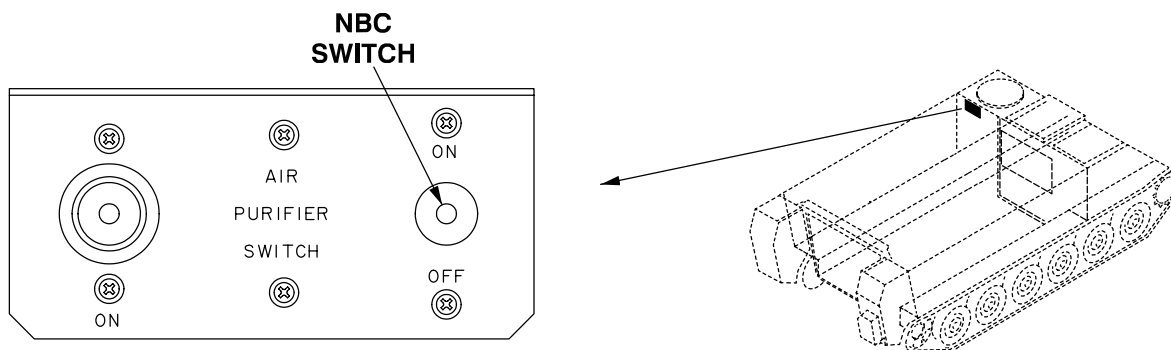

Table 7. NBC SWITCH ASSEMBLY

KEY	CONTROL OR INDICATOR	FUNCTION
	NBC POWER SWITCH	Turns blower in precleaner and particulate filter assembly on and off.

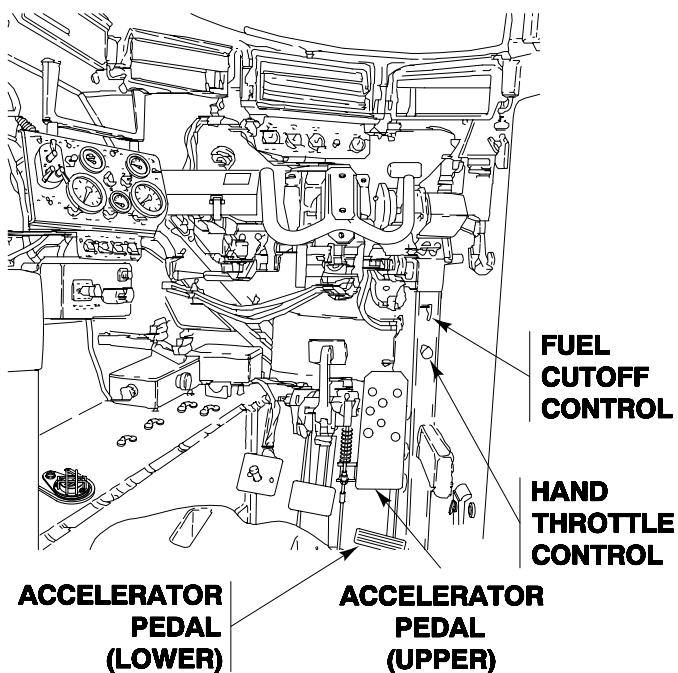

Table 8. FUEL AND THROTTLE CONTROLS

KEY	CONTROL OR INDICATOR	FUNCTION
	FUEL CUTOFF CONTROL	Starts and stops fuel flow to engine.
	HAND THROTTLE CONTROL	Allows engine speed to be controlled by hand.
	ACCELERATOR PEDAL (UPPER)	Controls engine speed. Used with driver's seat in raised position.
	ACCELERATOR PEDAL (LOWER)	Controls engine speed. Used with driver's seat in lowered position.

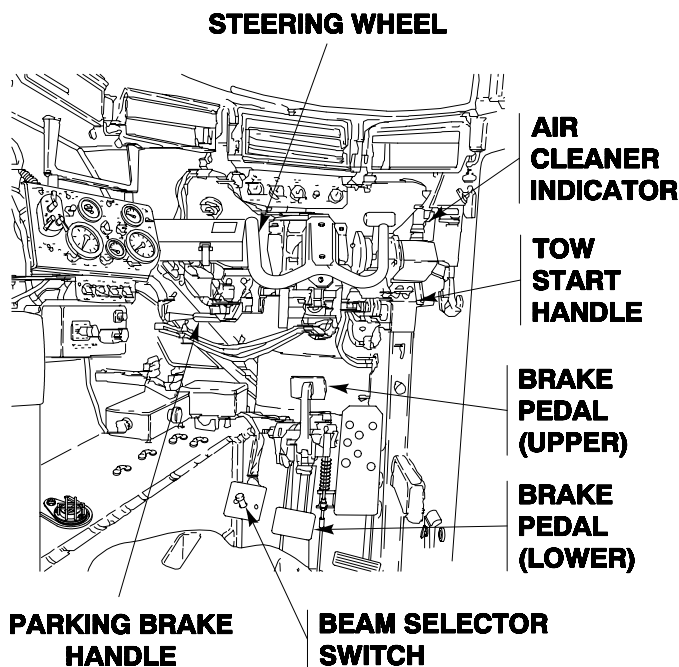

Table 9. DRIVER'S CONTROLS AND INDICATORS

KEY	CONTROL OR INDICATOR	FUNCTION
	STEERING WHEEL	Steers carrier.
	AIR CLEANER INDICATOR	Indicates condition of air cleaner element. With engine off, indicator should show all green in the window. With engine running, green sleeve should go part way up. If at any time only red is seen in the window, notify unit maintenance.
	TOW START HANDLE	Used only when attempting to start the engine by towing the carrier.
	BRAKE PEDAL (UPPER)	Slows and stops carrier. Used with driver's seat in raised position.
	BRAKE PEDAL (LOWER)	Slows and stops the carrier. Used with driver's seat in lowered position.
	BEAM SELECTOR SWITCH	Selects high or low headlight beams.
	PARKING BRAKE HANDLE	Engages parking brake.

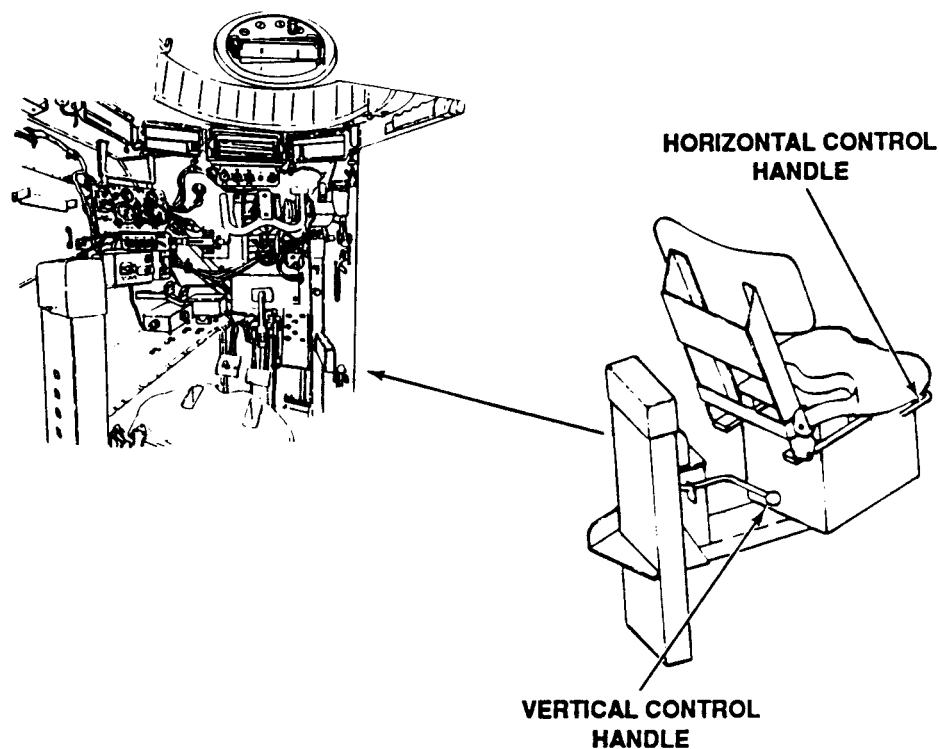

Table 10. DRIVER'S SEAT CONTROLS

KEY	CONTROL OR INDICATOR	FUNCTION
	HORIZONTAL CONTROL HANDLE	Locks and releases driver's seat. Allows seat to be moved to the front or rear.
	VERTICAL CONTROL HANDLE	Locks and releases driver's seat. Allows seat to be raised or lowered.

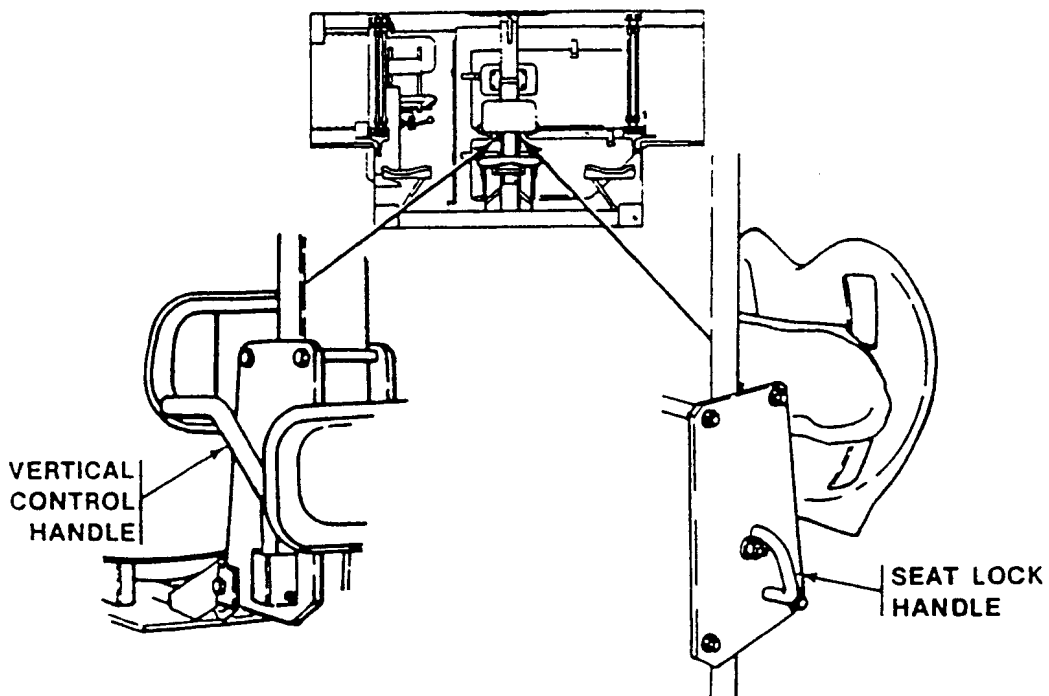
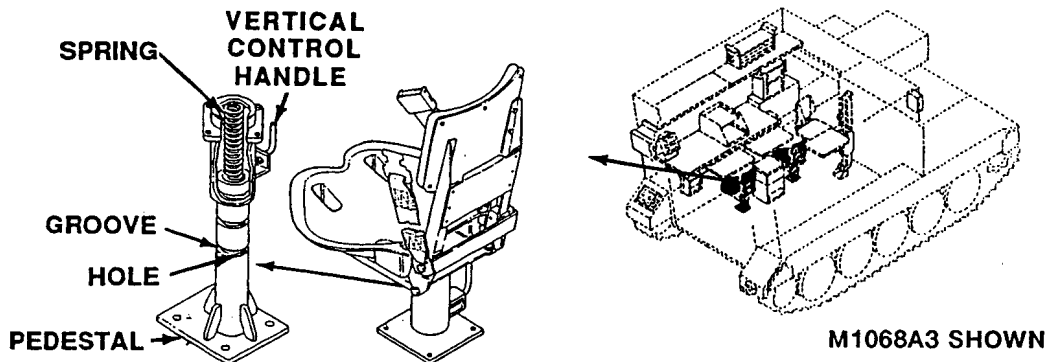

Table 11. COMMANDER'S SEAT CONTROLS (M113A3, M1059A3, M1064A3 AND M58 ONLY)

KEY	CONTROL OR INDICATOR	FUNCTION
	VERTICAL CONTROL HANDLE	Allows seat to be raised or lowered.
	SEAT LOCK HANDLE	Releases seat from stowed position.



WARNING



Do not apply full body weight to seat unless vertical control handle is engaged in one of the holes in the pedestal. If vertical control handle is not properly engaged, seat could fall and personnel could be injured.

Table 12. RADIO/SMOKE OPERATOR'S SEAT (M1068A3 AND M58 ONLY)

KEY	CONTROL OR INDICATOR	FUNCTION
	VERTICAL CONTROL HANDLE	Allows seat to be locked in three heights and two viewing angles (seat facing front or right side of vehicle). To raise seat, partially remove body weight from seat and pull out handle allowing spring to raise seat. To lower seat, pull out handle and use body to force seat down. When seat is near desired height, release handle and continue moving seat until spring-loaded handle engages groove in pedestal. Then, turn seat right or left until handle engages hole in pedestal to lock seat in place. To change viewing angle, reduce body weight exerted on seat, pull out handle, and turn seat toward the viewing angle desired. Release handle when seat is near desired viewing angle and continue turning seat until handle engages hole in pedestal.
	HORIZONTAL CONTROL HANDLE	Allows horizontal adjustment of seat. To operate, push up handle and slide seat forward or rearward as necessary. To lock in position, release handle and slide seat slightly forward or rearward until spring-loaded handle engages detent nearest desired position.

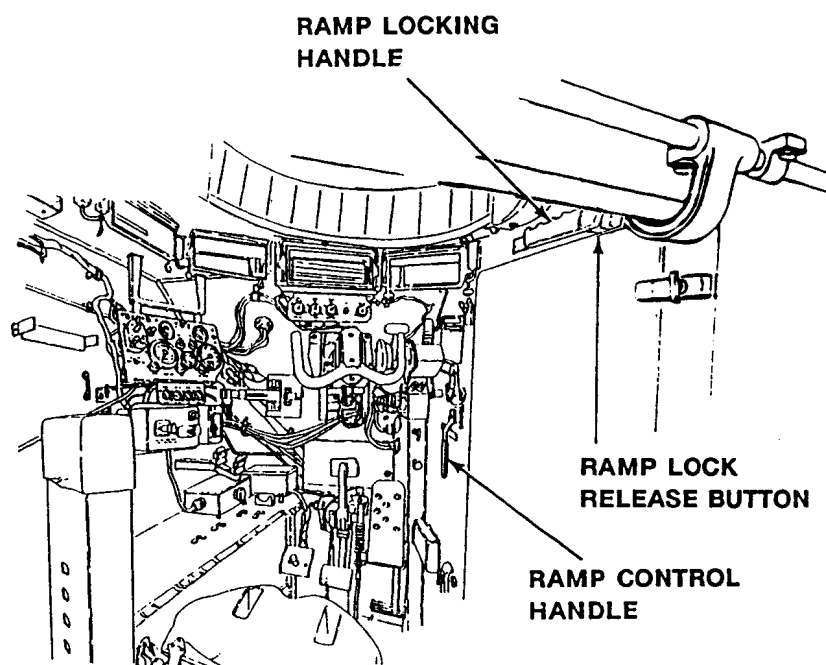

Table 13. RAMP CONTROLS

KEY	CONTROL OR INDICATOR	FUNCTION
	RAMP LOCK RELEASE BUTTON	Releases ramp locking handle.
	RAMP LOCKING HANDLE	Locks ramp in raised position and unlocks ramp for lowering.
	RAMP CONTROL HANDLE	Used to raise and lower ramp.

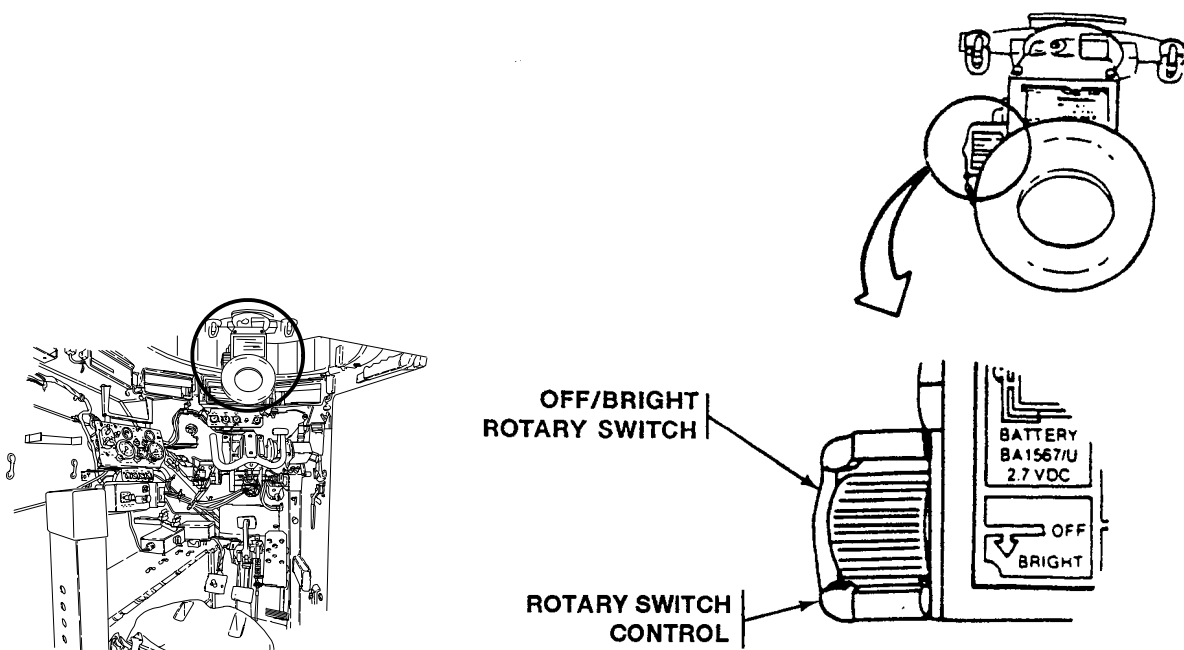

Table 14. AN/VVS-2 DRIVER'S NIGHT VISION

KEY	CONTROL OR INDICATOR	FUNCTION
	ROTARY SWITCH CONTROL	Used to adjust image brightness and to turn power on/off.

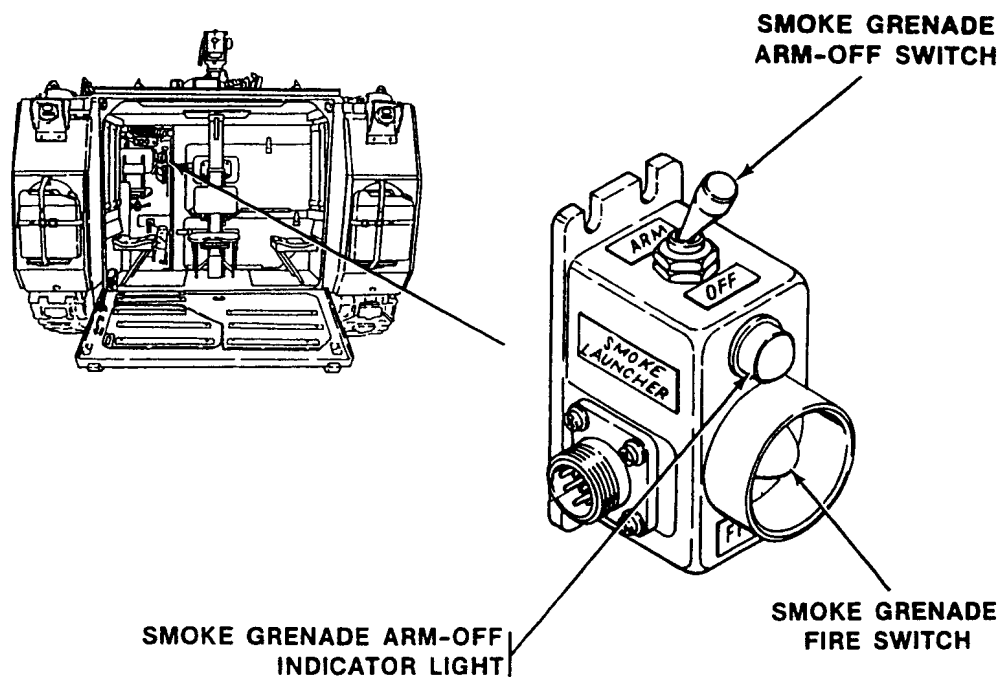

Table 15. SMOKE GRENADE ARMING FIRING UNIT (M113A3, M1059A3, AND M58 ONLY)

KEY	CONTROL OR INDICATOR	FUNCTION
	SMOKE GRENADE ARM - OFF SWITCH	Two-position toggle switch to arm and disarm smoke grenade FIRE switch.
	SMOKE GRENADE ARM - OFF INDICATOR LIGHT	Light comes on when smoke grenade FIRE switch is armed.
	SMOKE GRENADE FIRE SWITCH	Fires smoke grenades from discharger tubes when pushed.

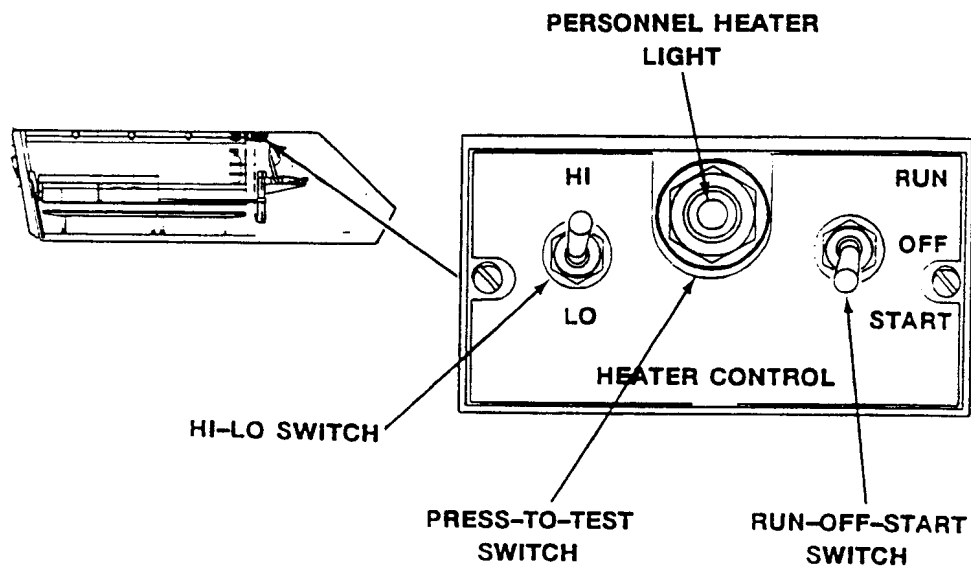

Table 16. PERSONNEL HEATER CONTROL BOX

KEY	CONTROL OR INDICATOR	FUNCTION
	HI-LO SWITCH	Controls personnel heater output.
	RUN-OFF-START SWITCH	Controls operation of personnel heater.
	PERSONNEL HEATER LIGHT	Indicates that personnel heater is on.
	PRESS-TO-TEST SWITCH	Test PERSONNEL HEATER light. When switch is pressed, light will come on if light bulb is good and if power is coming into control box.

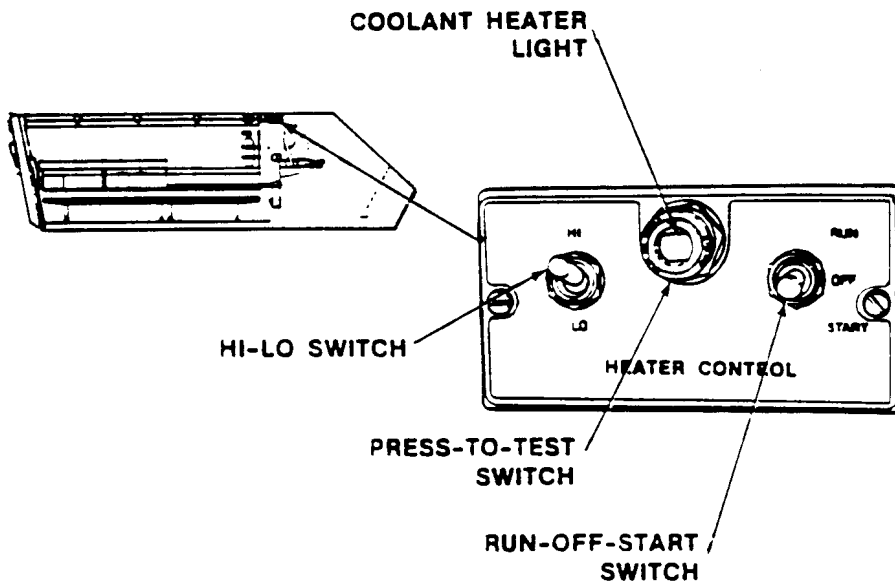

Table 17. ENGINE COOLANT HEATER CONTROL BOX

KEY	CONTROL OR INDICATOR	FUNCTION
	HI-LO SWITCH	Controls engine coolant heater output.
	COOLANT HEATER LIGHT	Indicates that coolant heater is on.
	PRESS-TO-TEST SWITCH	When switch is pressed, light will come on if light bulb is good and if power is coming into the control box.
	RUN-OFF-START SWITCH	Controls operation of coolant heater.

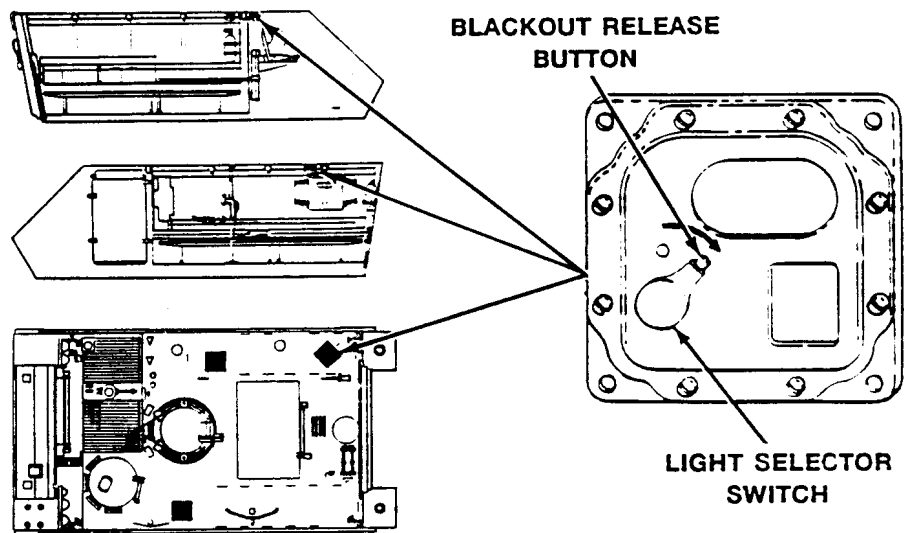

Table 18. DOME LIGHTS (ALL EXCEPT M577A3 AND M1068A3)

KEY	CONTROL OR INDICATOR	FUNCTION
	LIGHT SELECTOR SWITCH	Selects blackout or white light.
	BLACKOUT RELEASE BUTTON	Releases light selector switch from blackout position.

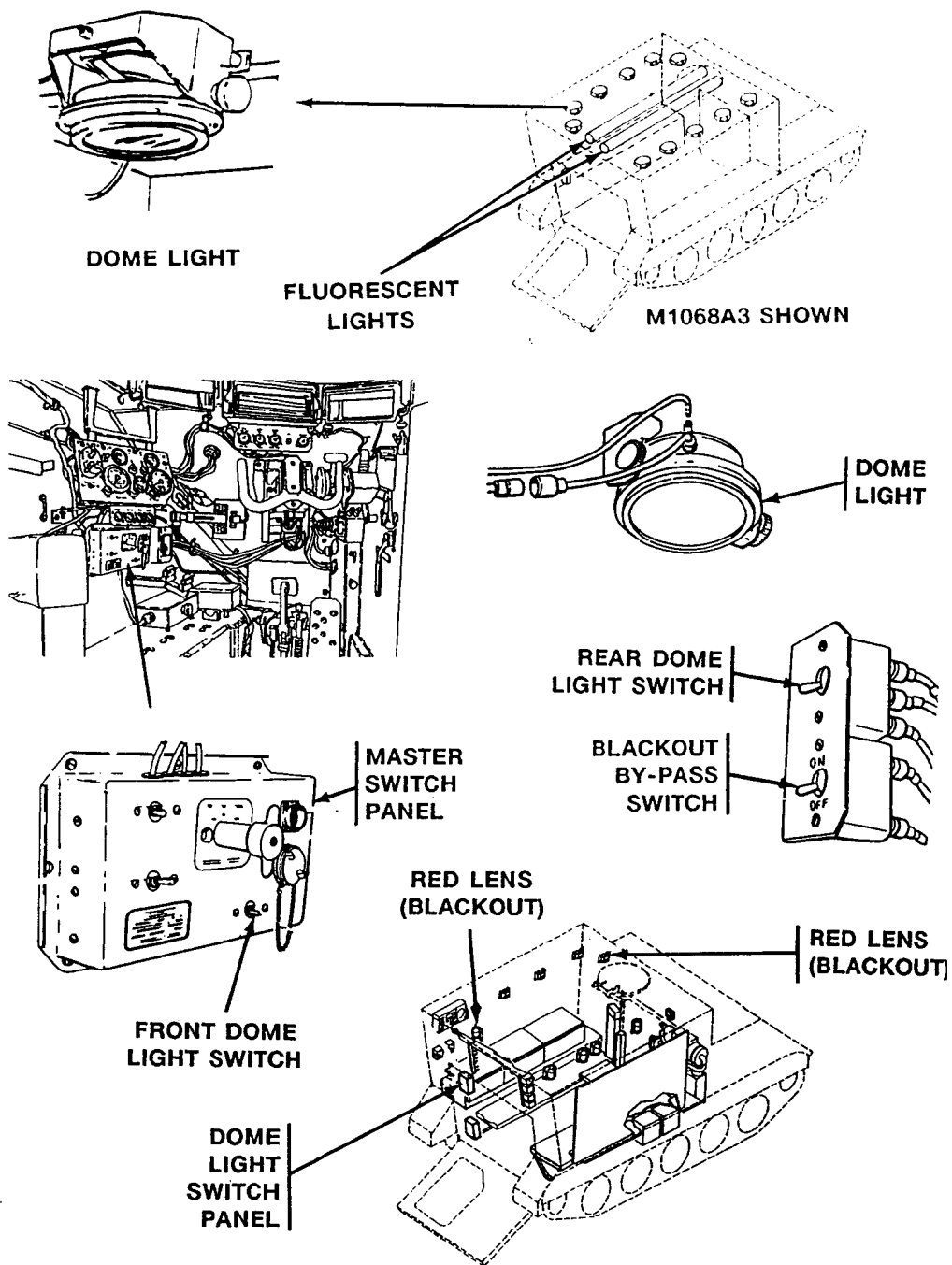
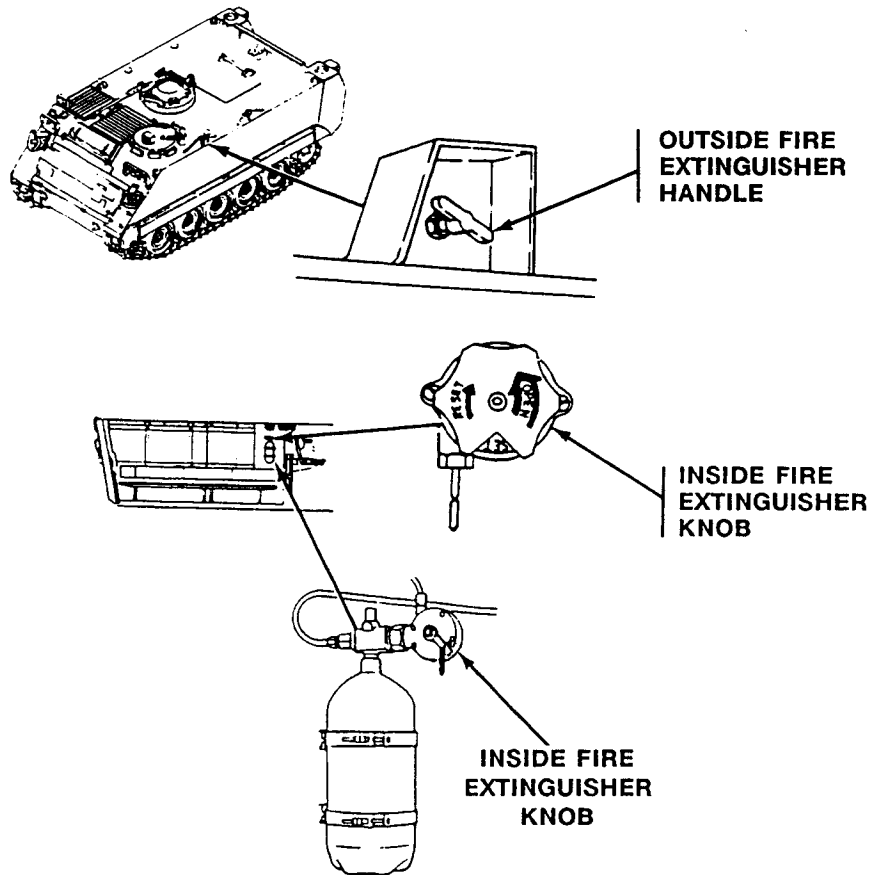

Table 19. DOME AND FLUORESCENT LIGHTS (M577A3 AND M1068A3 ONLY)

KEY	CONTROL OR INDICATOR	FUNCTION
	DOME LIGHT FRONT DOME LIGHT SWITCH REAR DOME LIGHT SWITCH BLACKOUT BY-PASS SWITCH	Is mounted on ceiling. There are nine dome lights (white lens) and two blackout dome lights (red lens). Controls the dome lights from the master switch panel. Controls the dome lights from the rear dome light switch panel near the ramp. Located on rear dome light switch panel. Must be in OFF position to control dome lights. See WP 0030 00 for operation.



NOTE

Fixed fire extinguisher located behind driver discharges into the engine compartment only.

Table 20. FIXED FIRE EXTINGUISHER SYSTEM

KEY	CONTROL OR INDICATOR	FUNCTION
	OUTSIDE FIRE EXTINGUISHER HANDLE	Discharges fixed fire extinguisher manually from outside carrier.
	INSIDE FIRE EXTINGUISHER KNOB	Discharges fixed fire extinguisher manually from inside carrier.

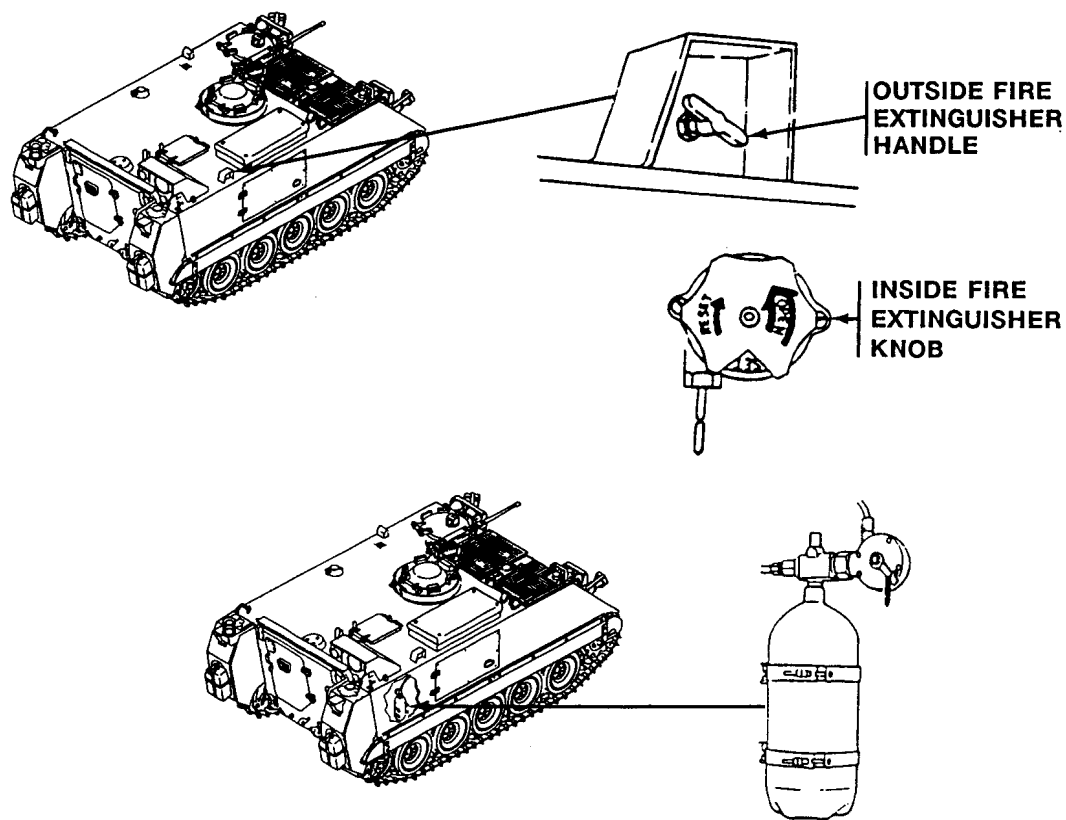

NOTE

Fixed fire extinguisher located on right side discharges into the turbine compartment only.

Table 21. FIXED FIRE EXTINGUISHER SYSTEM (M58 ONLY)

KEY	CONTROL OR INDICATOR	FUNCTION
	OUTSIDE FIRE EXTINGUISHER HANDLE	Discharges fixed fire extinguisher manually from outside carrier.
	INSIDE FIRE EXTINGUISHER KNOB	Discharges fixed fire extinguisher manually from inside carrier.

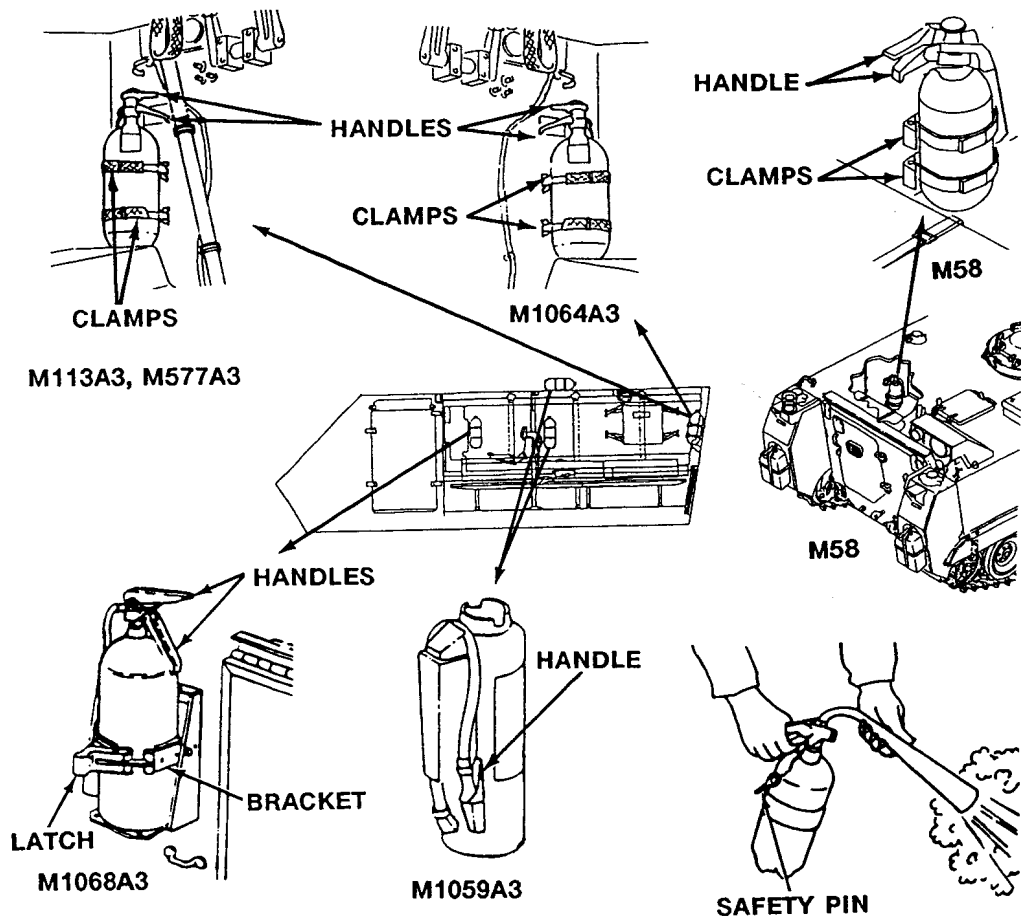

NOTE

M1064A3 portable fire extinguisher is located on left rear wall. M58 portable fire extinguisher is located on left side wall.

Table 22. PORTABLE FIRE EXTINGUISHER

KEY	CONTROL OR INDICATOR	FUNCTION
	CLAMPS (M113A3, M577A3, M1064A3, M1059A3, and M58)	Hold portable fire extinguisher in right rear of personnel compartment.
	LATCH AND BRACKET (M1068A3)	Hold portable fire extinguisher in front of personnel compartment.
	SAFETY PIN	Keep fire extinguisher from accidentally discharging while stowed.
	HANDLES	Discharges fire extinguisher when squeezed together.

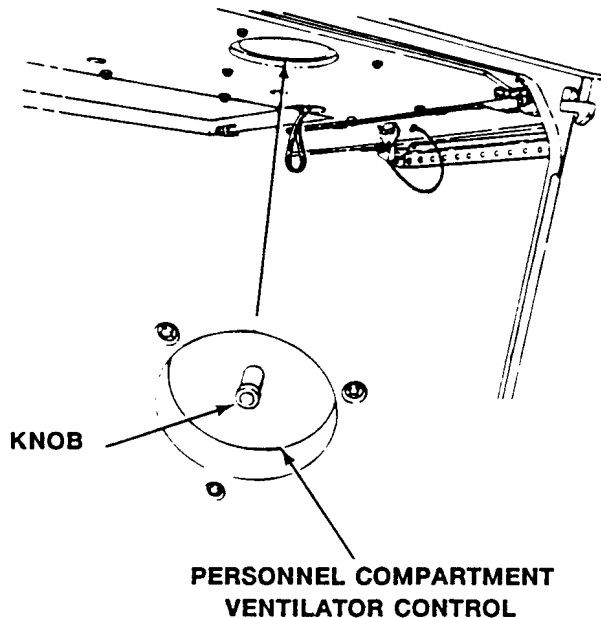

NOTE

This ventilator is located in the ceiling of the personnel compartment and is used with the front ventilator and the ventilating fan to let fresh air into the personnel compartment.

Table 23. PERSONNEL COMPARTMENT VENTILATOR CONTROL

KEY	CONTROL OR INDICATOR	FUNCTION
	KNOB	Push knob up to ventilate; pull knob down to close ventilator valve.

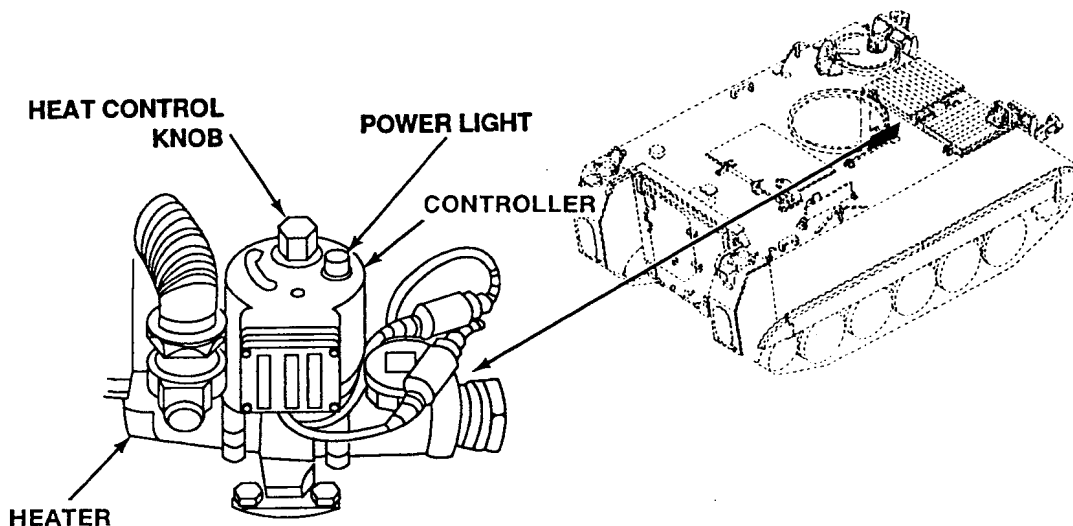

NOTE

In some vehicles the electric air heater's controller is located separate from the heater.

Table 24. ELECTRIC AIR HEATER

KEY	CONTROL OR INDICATOR	FUNCTION
	HEAT CONTROL KNOB	Allows operator to turn heater on and off and select desired amount of heat.
	POWER LIGHT	Lights when heating element is on.

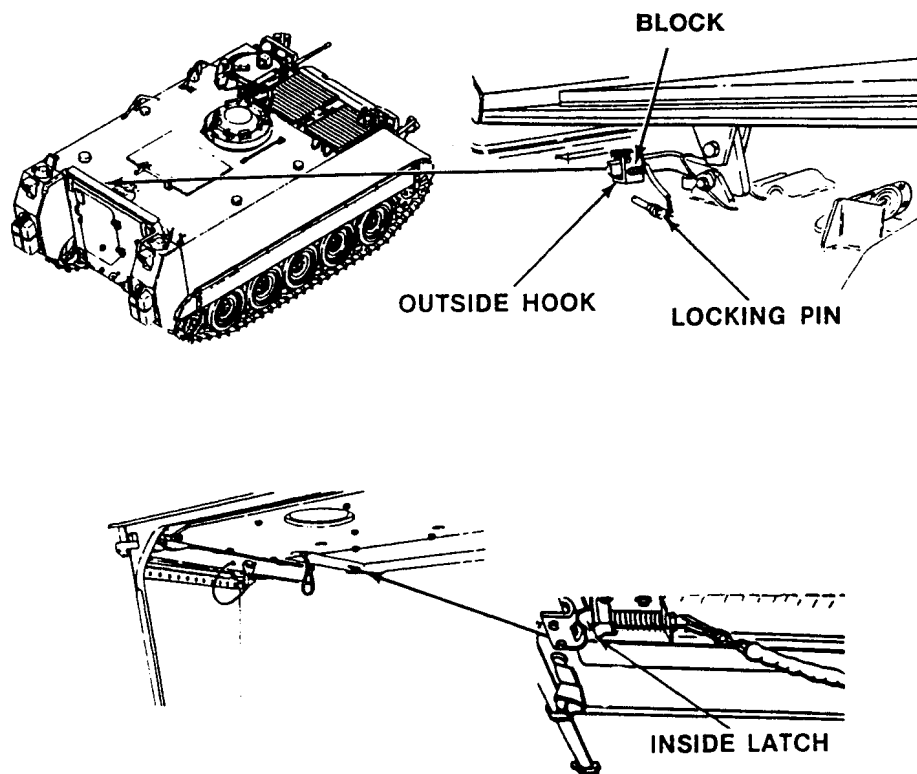

Table 25. CARGO HATCH CONTROLS (M113A3 AND M1059A3 ONLY)

KEY	CONTROL OR INDICATOR	FUNCTION
	OUTSIDE HOOK AND LOCKING PIN INSIDE LATCH BLOCK	Locks cargo hatch cover in fully open position. Locking pin is provided to secure hook and prevent accidental release of hatch cover. Locks and unlocks cargo hatch cover from inside carrier. Stowed location for locking pin when cargo hatch is closed. Block prevents pin from breaking away from chain.

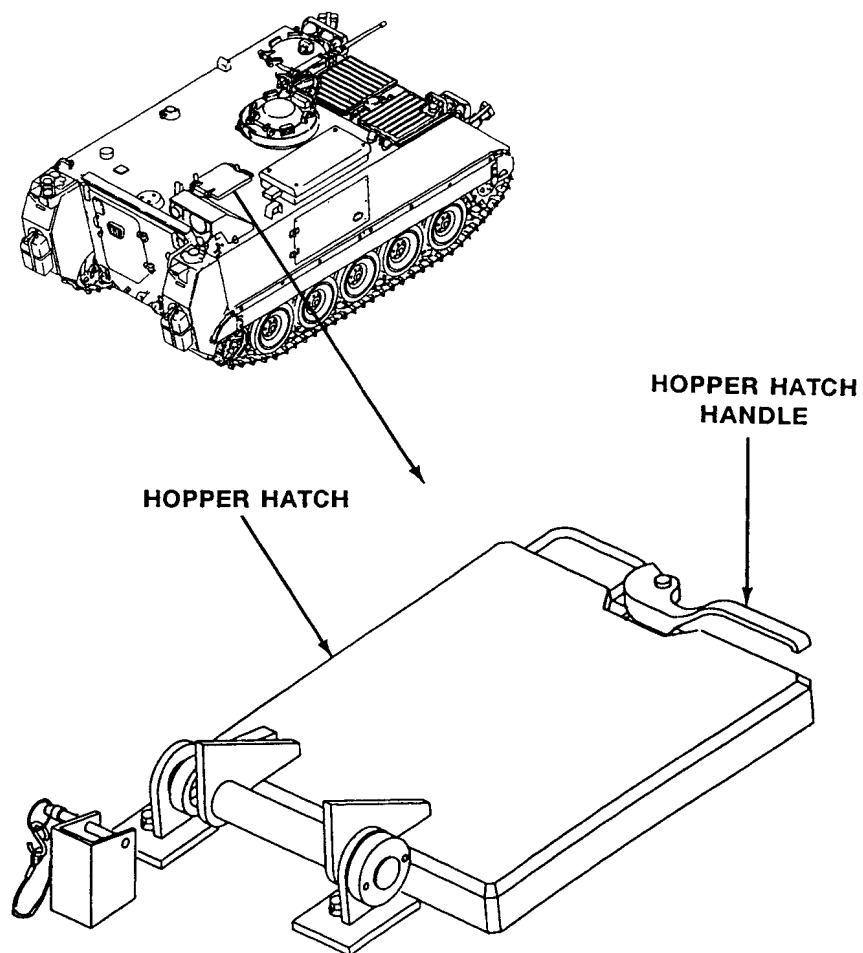

Table 26. HOPPER HATCH CONTROLS (M58 ONLY)

KEY	CONTROL OR INDICATOR	FUNCTION
	HOPPER HATCH HANDLE	Latches and unlatches hopper hatch from top of carrier.

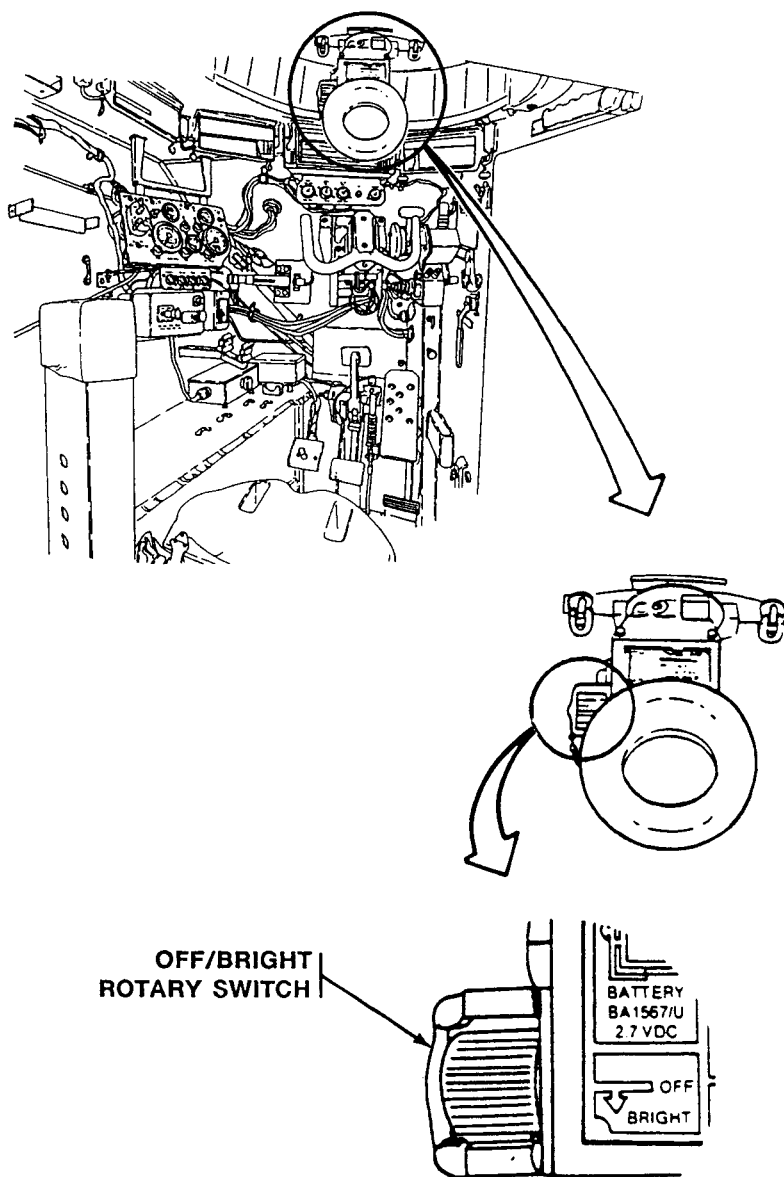

Table 27. DRIVER'S NIGHT VIEWER (ALL EXCEPT M58)

KEY	CONTROL OR INDICATOR	FUNCTION
	OFF/BRIGHT ROTARY SWITCH	Turns on driver's night viewer and adjusts brightness of view.

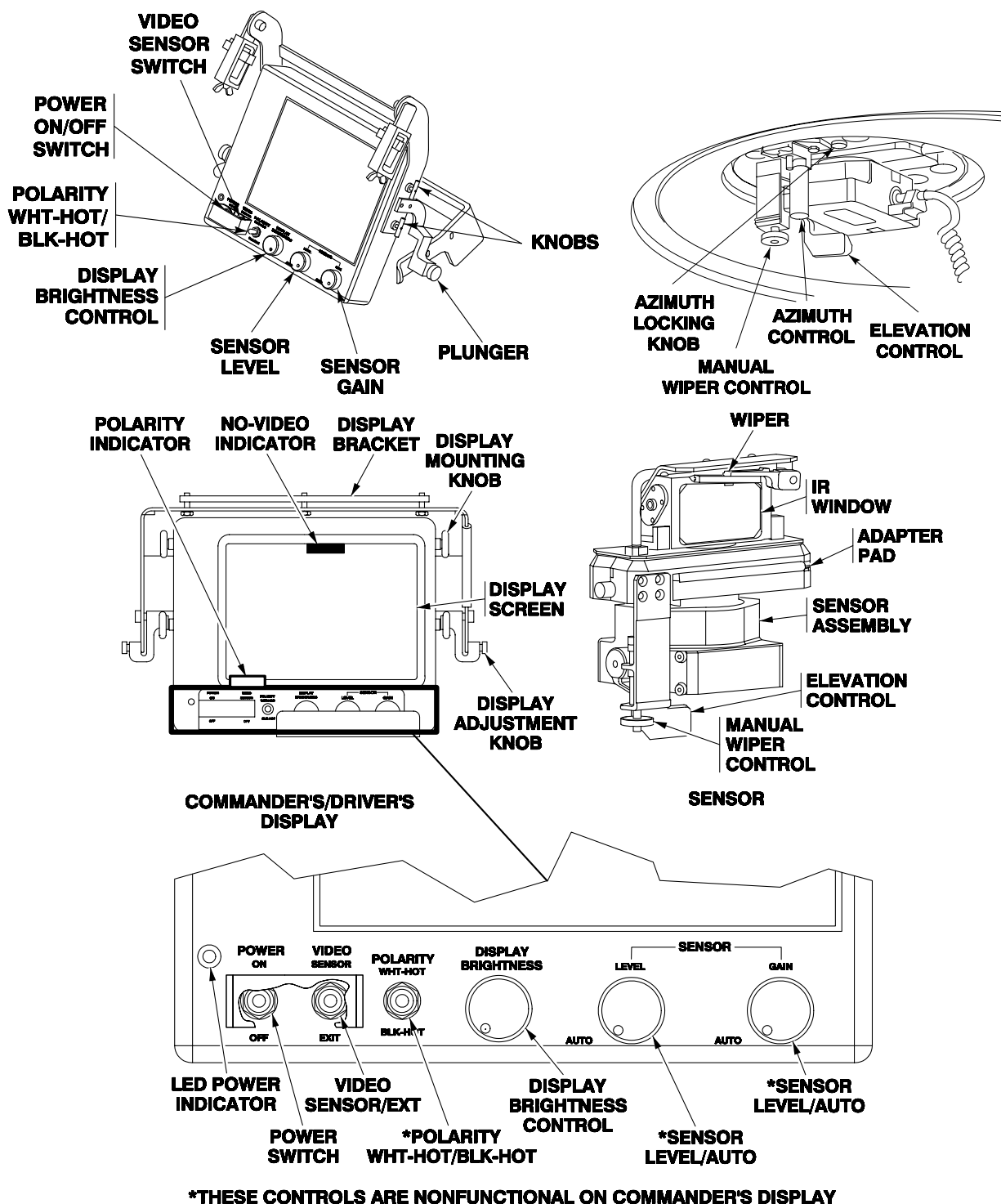

Table 28. AN/VAS-5 DRIVER'S/COMMANDER'S VISION ENHANCER (M58 ONLY)

KEY	CONTROL OR INDICATOR	FUNCTION
	POWER ON/OFF SWITCH	Applies power to DVE when set to ON (up position). When power is applied, LED power indicator is illuminated.
	VIDEO SENSOR/EXT SWITCH	In SENSOR position, selects sensor video in DVE. In EXT position, selects an external video input.
	POLARITY WHT-HOT/BLK-HOT	Reverses scene polarity. WHT-HOT (up position) displays hot objects as lighter than cooler objects. BLK-HOT (down position) displays hot objects as darker than cooler objects.
	DISPLAY BRIGHTNESS CONTROL	Increases background lighting on display with clockwise (CW) rotation or control and decreases background lighting on display with counterclockwise (CCW) rotation of control.
	SENSOR CONTROLS	Dual-action controls for choice of video dynamic range control - Automatic (full CCW detent position) or Manual (CW out of detent position).
	SENSOR LEVEL — MANUAL OR AUTO	Manual adjustment of video level or AUTO for automatic adjustment of video level.
	SENSOR GAIN	Manual adjustment of video gain or AUTO for automatic adjustment of video gain.
	MANUAL WIPER CONTROL	Allows manual operation of window wiper by pulling down and releasing control knob.
	ELEVATION CONTROL	Adjusts Head Mirror elevation Field of Regard (FOR) +10 degrees. A single detent (handle full forward) is provided at level 0 degrees position to assist driver in returning to normal driving level position.
	AZIMUTH CONTROL	Rotates Head Mirror FOR ± 30 degrees.
	AZIMUTH LOCK KNOB	Locks Head Mirror at 0 degrees azimuth position when AZIMUTH LOCK is released. Press AZIMUTH LOCK to unlock Head Mirror.
	DISPLAY TILT CONTROLS HOLD DOWN BRACKET ASSEMBLY	Knobs on both sides of DISPLAY MODULE and plunger on hold down assembly permit viewing angle adjustment of display.

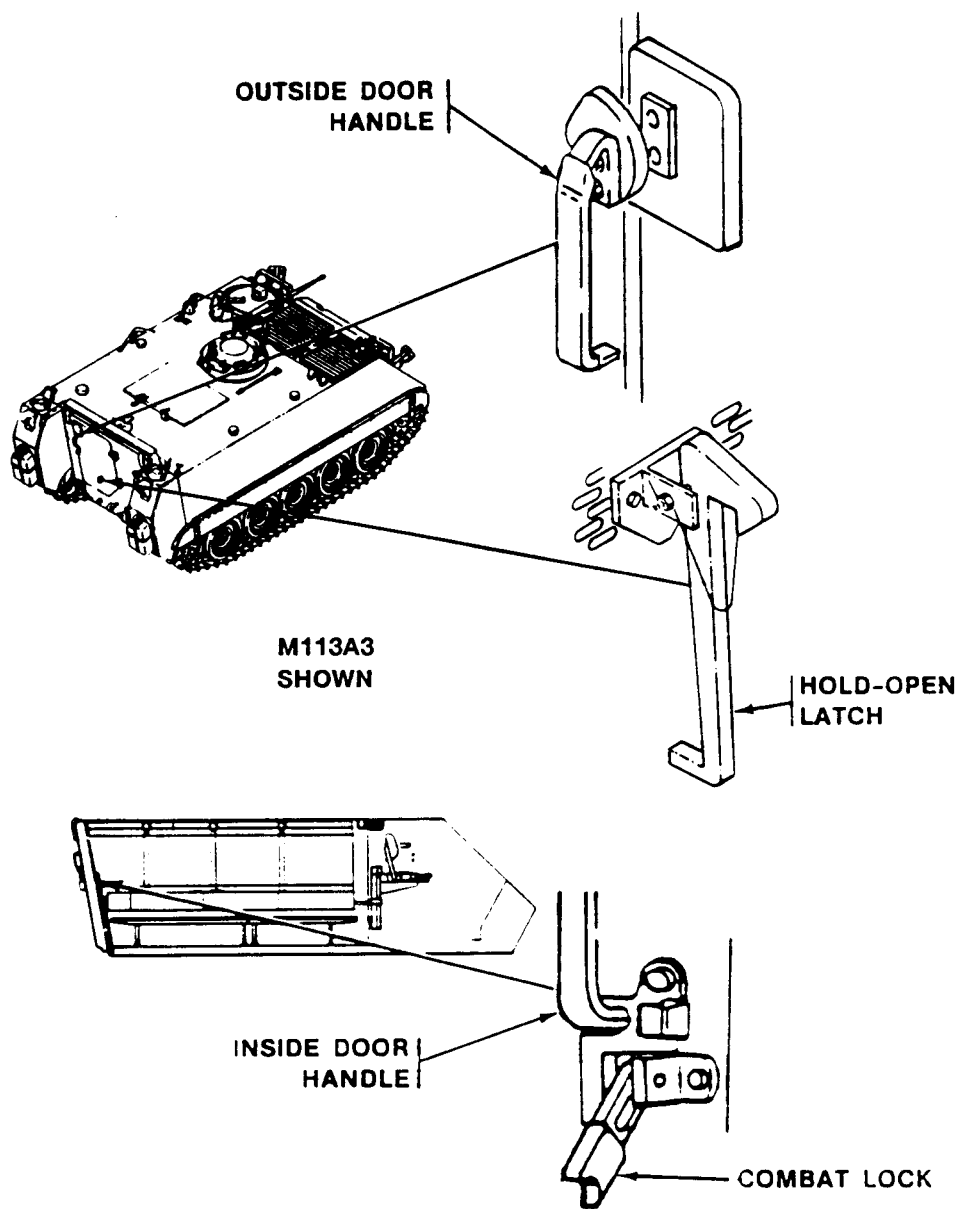

Table 29. RAMP ACCESS DOOR CONTROLS

KEY	CONTROL OR INDICATOR	FUNCTION
	OUTSIDE DOOR HANDLE	Latches and unlatches ramp access door from outside carrier.
	HOLD-OPEN LATCH	Secures ramp access door in open position.
	INSIDE DOOR HANDLE	Latches and unlatches ramp access door from inside carrier.
	COMBAT LOCK	Locks ramp access door from inside carrier.

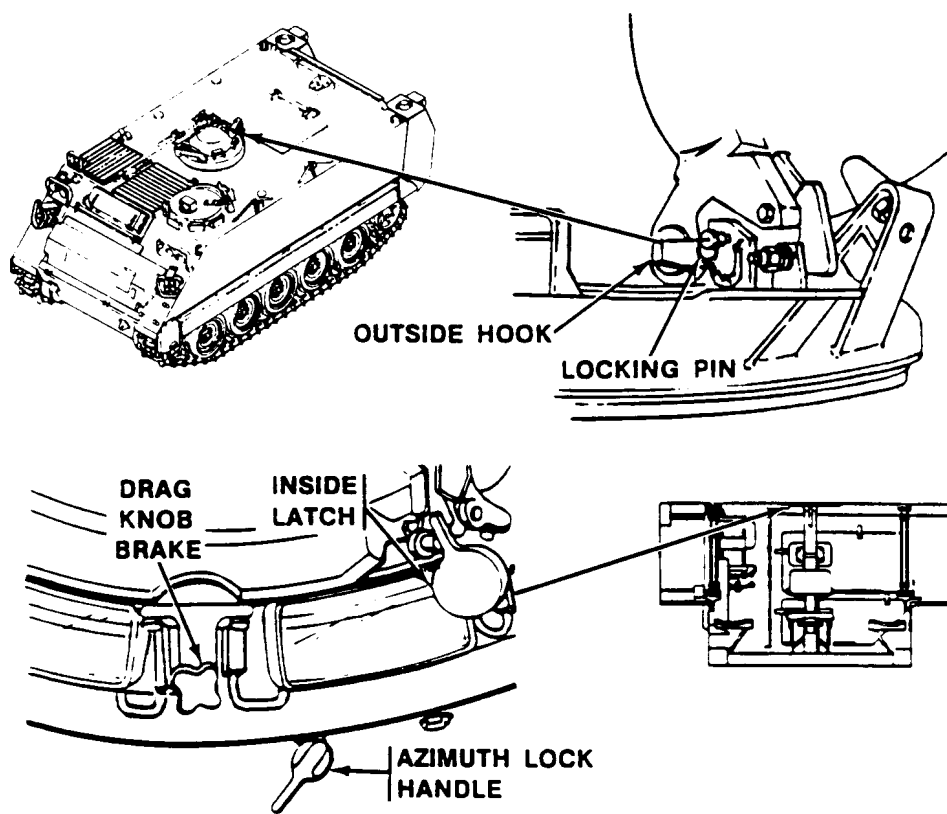

Table 30. COMMANDER'S CUPOLA CONTROLS (M113A3, M1059A3, AND M1064A3 ONLY)

KEY	CONTROL OR INDICATOR	FUNCTION
	OUTSIDE HOOK AND LOCKING PIN	Locks commander's hatch cover in fully open position. Locking pin is provided to secure hook and prevent accidental release of hatch cover.
	AZIMUTH LOCK HANDLE	Locks the cupola at any desired position.
	INSIDE LATCH	Locks and unlocks commander's hatch cover from inside carrier.
	DRAG BRAKE KNOB	Controls drag brake to slow and stop cupola movement.

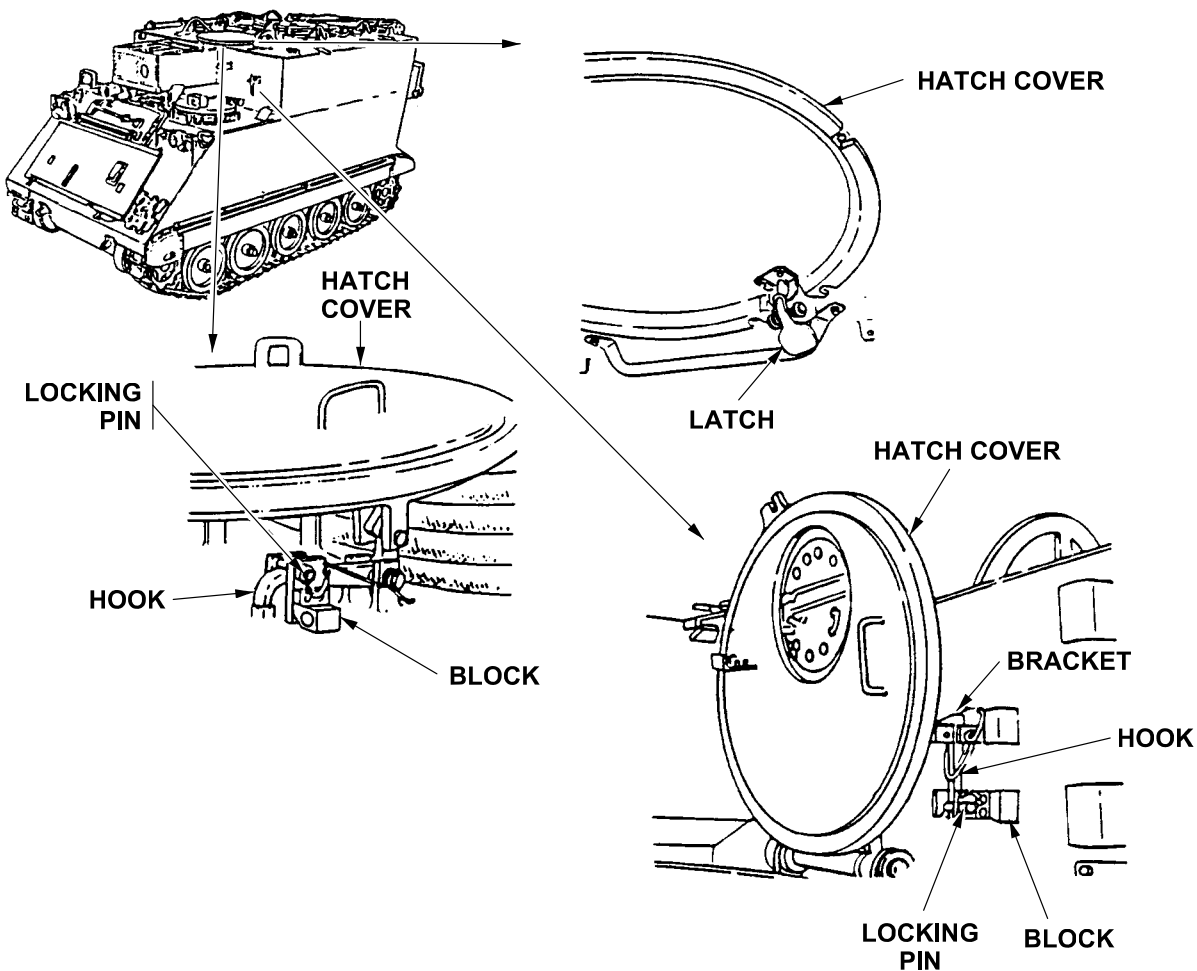

Table 31. COMMANDER'S HATCH CONTROLS (M577A3 AND M1068A3 ONLY)

KEY	CONTROL OR INDICATOR	FUNCTION
	LOCKING PIN	Locks commander's hatch cover in fully open position. Locking pin is provided to secure hook and prevent accidental release of hatch cover. Stored in block to prevent getting lost.
	BLOCK	Stores locking pin when commander's hatch cover is closed.
	LATCH	To open and secure closed the commander's hatch cover.
	OUTSIDE LATCH HOOK	To secure commander's hatch cover open, the locking pin ensures it stays locked.

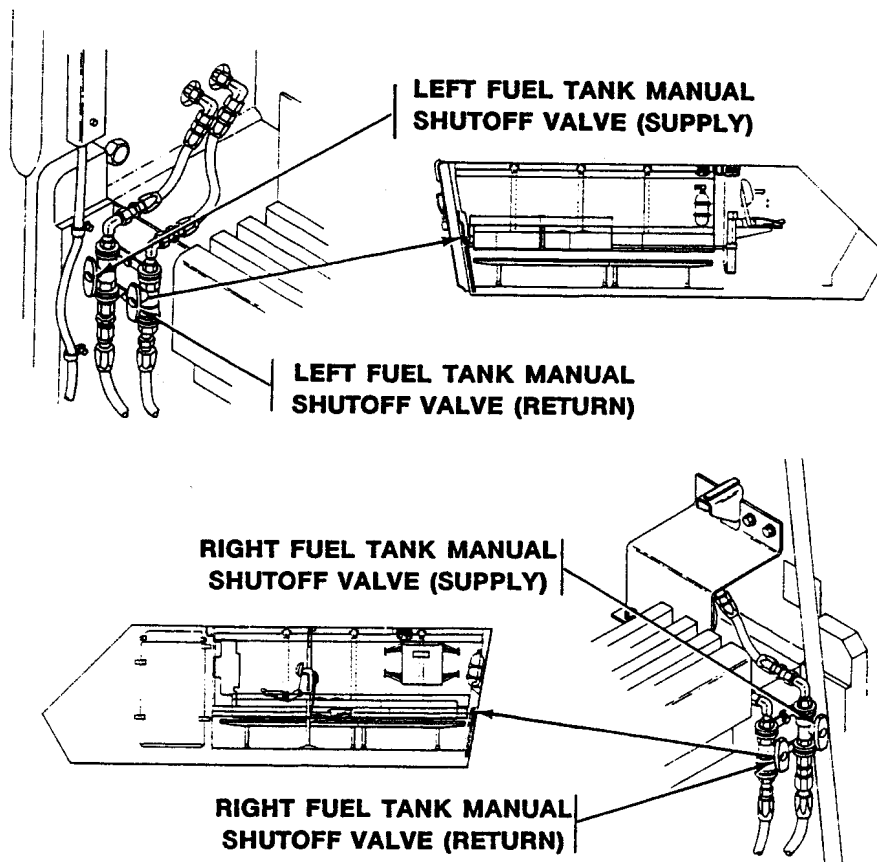

Table 32. FUEL TANKS MANUAL SHUTOFF VALVES (ALL EXCEPT M577A3 AND M1068A3)

KEY	CONTROL OR INDICATOR	FUNCTION
	LEFT FUEL TANK MANUAL SHUTOFF VALVE (SUPPLY)	Starts and stops fuel flow from left fuel tank to engine.
	LEFT FUEL TANK MANUAL SHUTOFF VALVE (RETURN)	Starts and stops fuel flow from engine to left fuel tank.
	RIGHT FUEL TANK MANUAL SHUTOFF VALVE (SUPPLY)	Starts and stops fuel flow from right fuel tank to engine.
	RIGHT FUEL TANK MANUAL SHUTOFF VALVE (RETURN)	Starts and stops fuel flow from engine to right fuel tank.

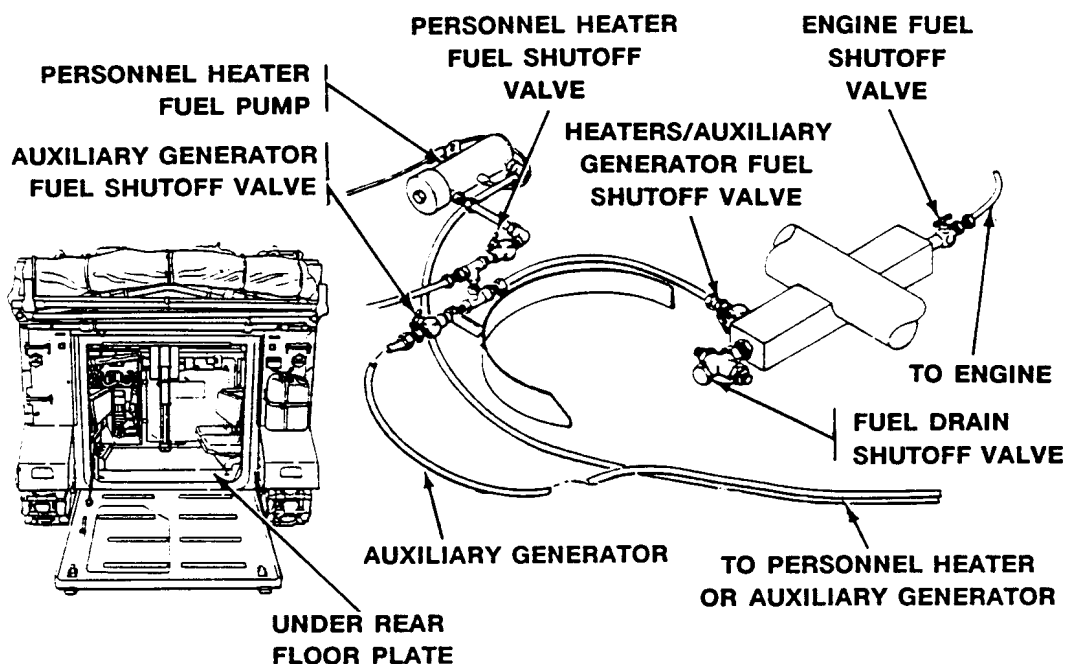

Table 33. FUEL TANKS MANUAL SHUTOFF VALVES (M577A3 AND M1068A3 ONLY)

KEY	CONTROL OR INDICATOR	FUNCTION
	ENGINE FUEL SHUTOFF VALVE (SUPPLY)	Starts and stops fuel flow from both fuel tanks to engine.
	HEATER/AUXILIARY GENERATOR FUEL SHUTOFF VALVE	Starts and stops fuel flow from both fuel tanks to personnel heater, auxiliary generator, and coolant heater.
	PERSONNEL HEATER FUEL SHUTOFF VALVE	Starts and stops fuel flow to personnel heater fuel pump.
	AUXILIARY GENERATOR FUEL SHUTOFF VALVE	Starts and stops fuel flow to auxiliary generator.
	FUEL DRAIN SHUTOFF VALVE	Allows for hose to be connected and draining fuel into proper container for reuse or proper disposal.

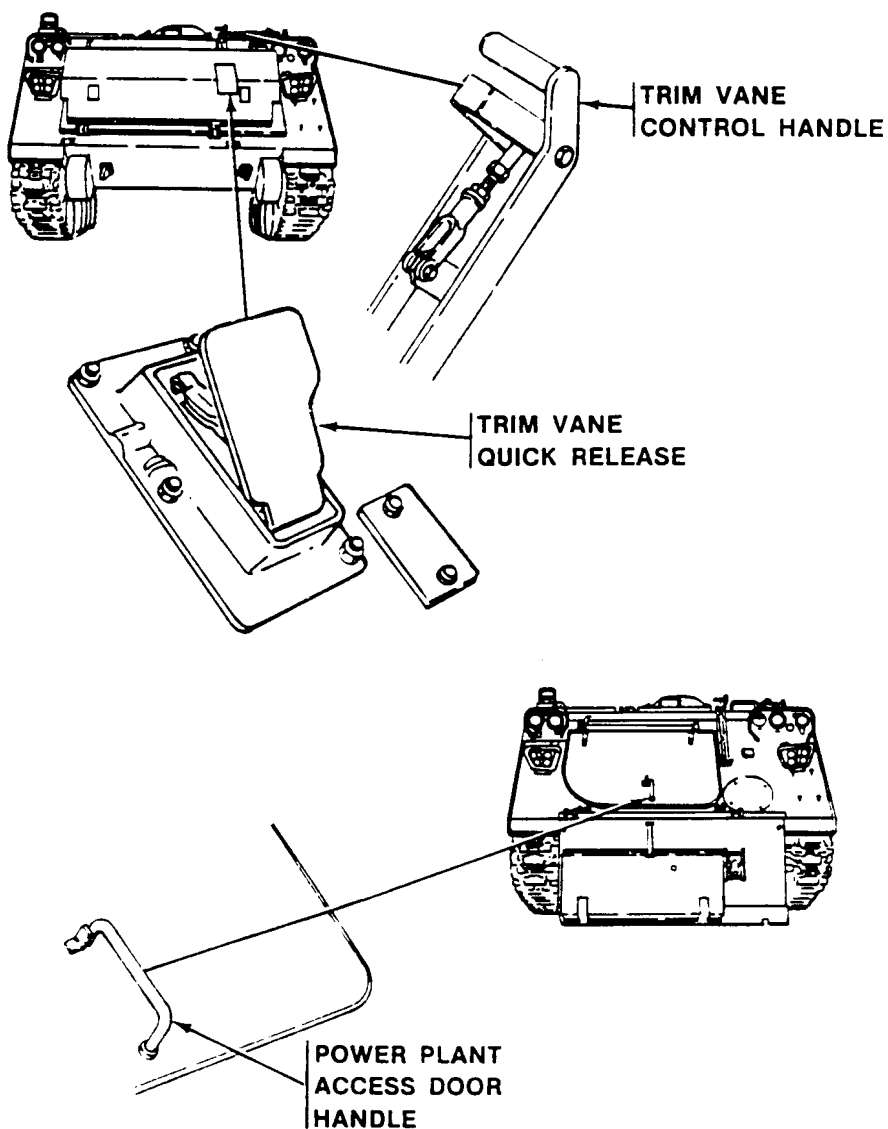

Table 34. TRIM VANE AND POWER PLANT ACCESS DOOR CONTROLS

KEY	CONTROL OR INDICATOR	FUNCTION
	TRIM VANE CONTROL HANDLE	Locks trim vane in position for water operation and in stowed position.
	TRIM VANE QUICK RELEASE	Locks trim vane to actuator arm and unlocks trim vane for lowering.
	POWER PLANT ACCESS DOOR HANDLE	Locks and unlocks power plant access door.

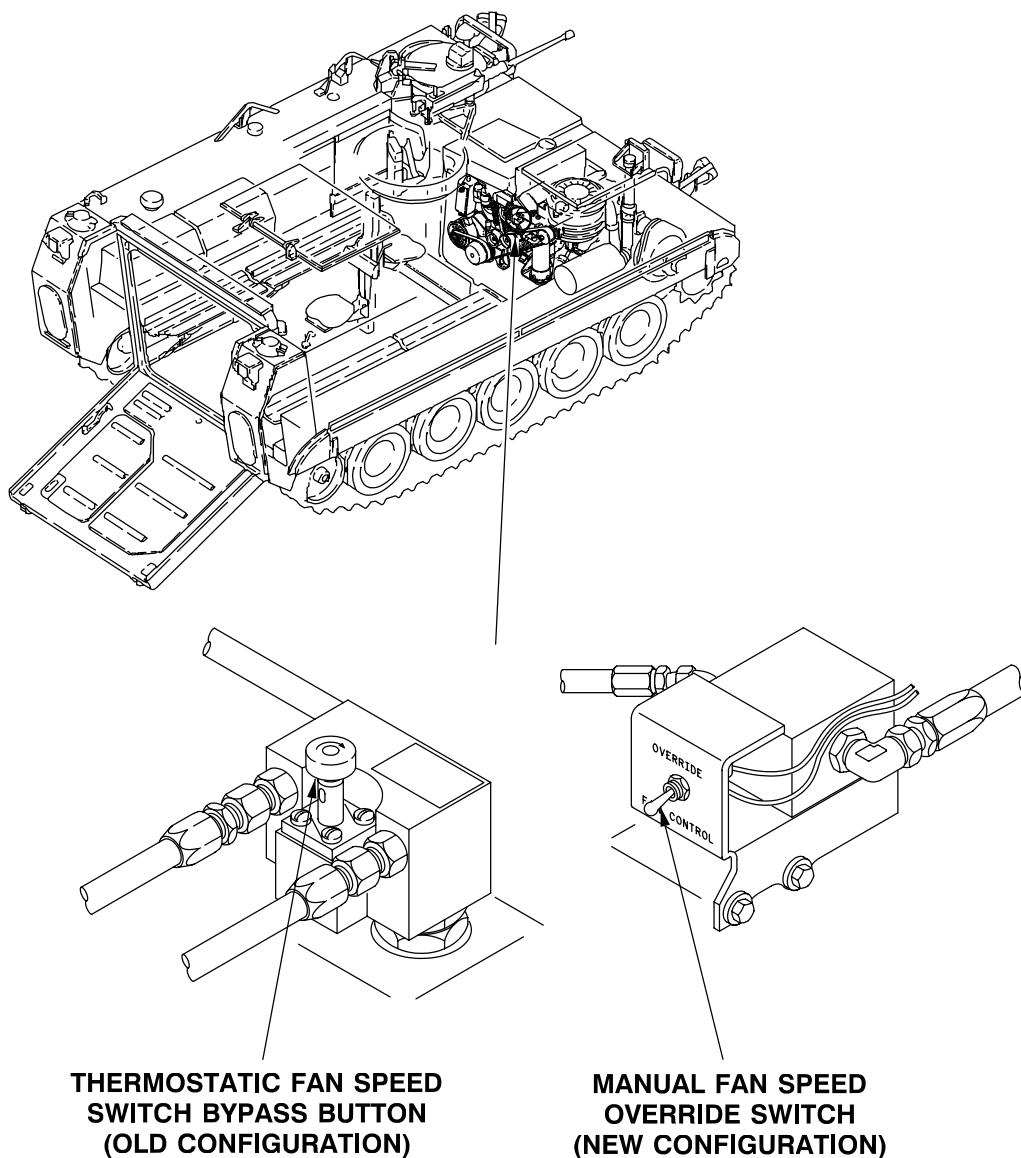
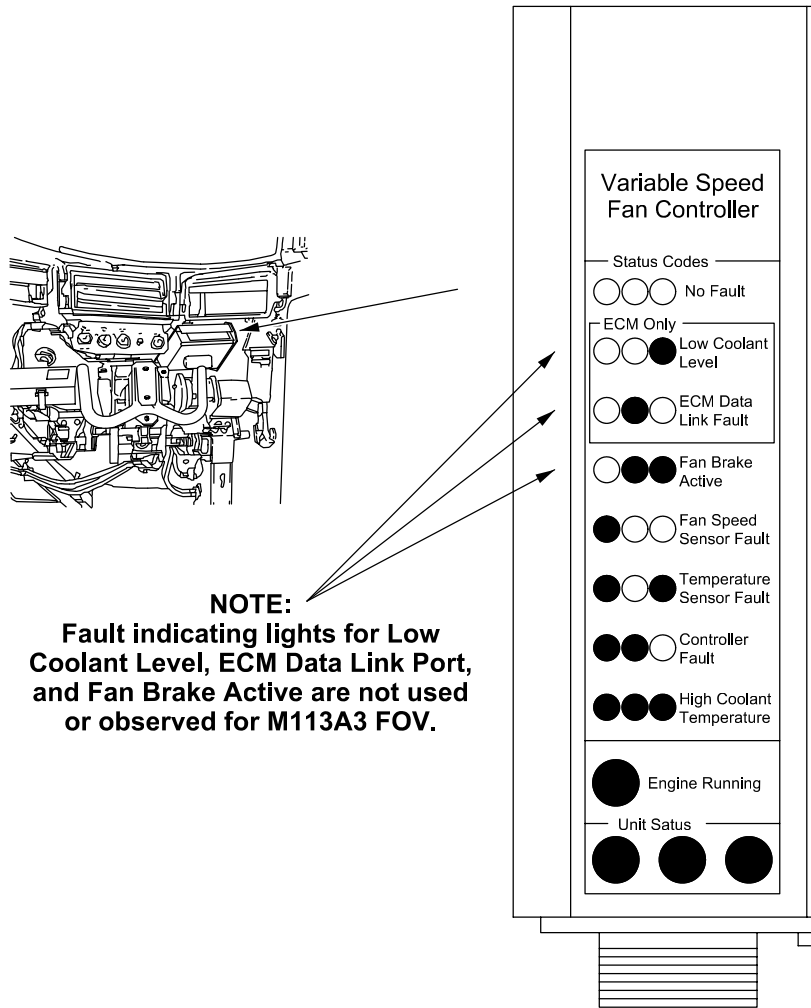

Table 35. THERMOSTATIC FAN SPEED SWITCH BYPASS BUTTON

KEY	CONTROL OR INDICATOR	FUNCTION
	THERMOSTATIC FAN SPEED SWITCH BYPASS BUTTON (OLD CONFIGURATION) MANUAL FAN SPEED OVERRIDE SWITCH (NEW CONFIGURATION)	Allows you to change the variable speed coolant fan drive to a constant speed coolant fan drive by bypassing the thermostatic fan speed switch. Allows you to change the variable speed coolant fan drive to a constant speed coolant fan drive by bypassing variable fan speed drive controller.



NOTE:
 Fault indicating lights for Low Coolant Level, ECM Data Link Port, and Fan Brake Active are not used or observed for M113A3 FOV.

Table 36. VARIABLE SPEED FAN CONTROLLER INDICATOR

KEY	CONTROL OR INDICATOR	FUNCTION
	VARIABLE SPEED FAN CONTROLLER	Allows you to determine if the variable speed fan is functioning properly. Light positions determine proper function or possible faults.

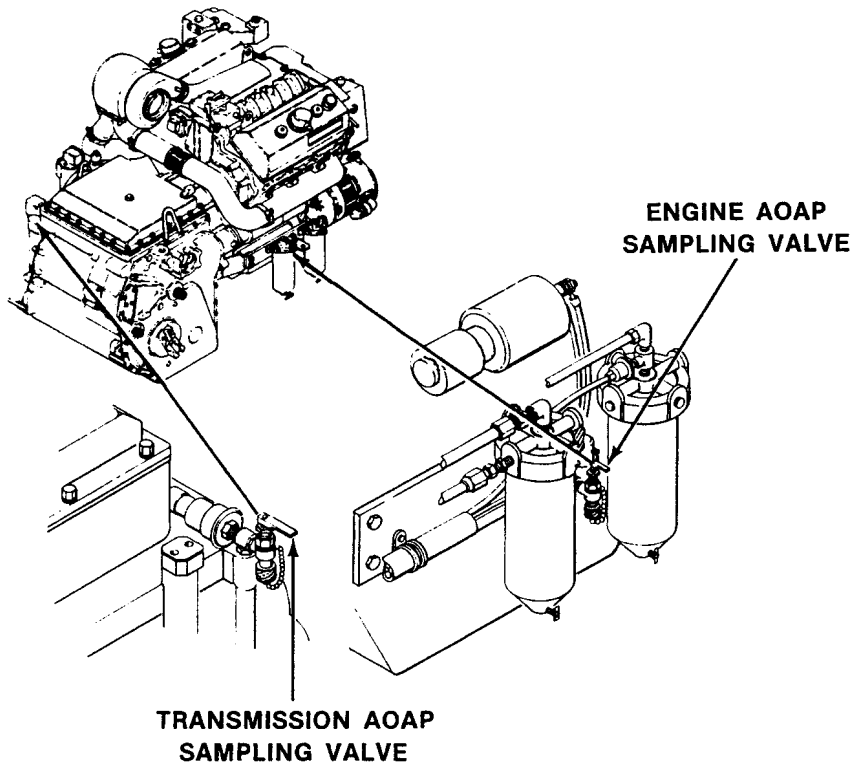

NOTE

See WP 0090 00 for instructions on taking transmission and engine AOAP oil sample.

Table 37. ARMY OIL ANALYSIS PROGRAM (AOAP) SAMPLING VALVE

KEY	CONTROL OR INDICATOR	FUNCTION
	TRANSMISSION AOAP SAMPLING VALVE	Used to draw transmission oil sample for AOAP testing.
	ENGINE AOAP SAMPLING VALVE	Used to draw engine oil sample for AOAP testing.

OPEN/CLOSE RAMP ACCESS DOOR

0005 00

THIS WORK PACKAGE COVERS:

Open Ramp Access Door From Inside Carrier (page 0005 00-1). Close Ramp Access Door From Inside Carrier (page 0005 00-2). Open Ramp Access Door From Outside Carrier (page 0005 00-3). Close Ramp Access Door From Outside Carrier (page 0005 00-4).

INITIAL SETUP:

Maintenance Level

Operator

Equipment Condition

Carrier parked

Personnel Required

Soldier

OPEN RAMP ACCESS DOOR FROM INSIDE CARRIER

WARNING

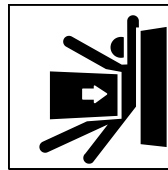

Ramp access door is heavy. It can swing and injure personnel. Make sure no one is in the area of ramp access door when it is opening. Secure door in ramp door hook before you go out.

1. Release combat lock and raise inside door handle until ramp access door is released.

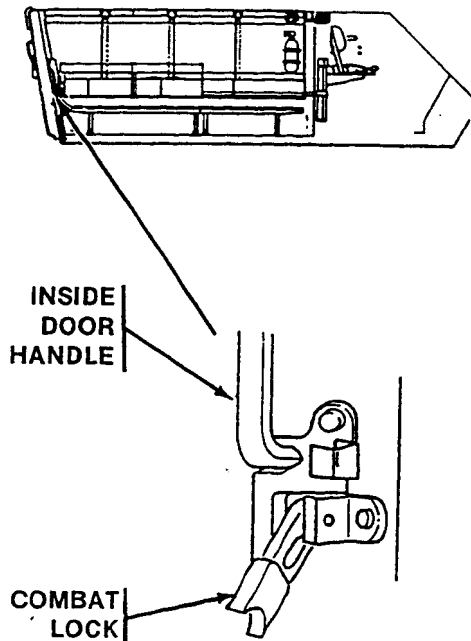

NOTE

If mission requirements permit, allow the ramp door to remain open to ensure adequate ventilation.

- Swing ramp access door outward until ramp access door hook engages in door retainer.

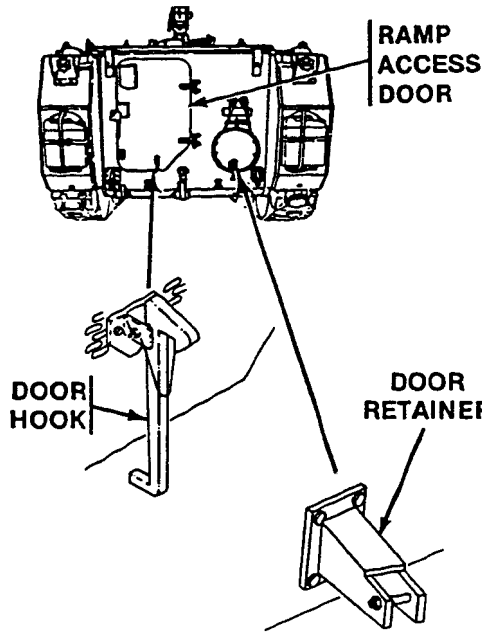

CLOSE RAMP ACCESS DOOR FROM INSIDE CARRIER

WARNING



Ramp access door is heavy. It can swing and injure personnel. Stand clear when you release ramp access door hook.

WARNING



The use of the left hand to grasp and close the ramp access door will expose the thumb to being extended beyond the door's edge and possible amputation when the door is pulled closed. When using the left hand, use only the center of the handhold and be aware of thumb position.

- Pull ramp access door hook to release ramp access door.

2. Swing ramp access door closed. Lower inside door handle until it hits stop on combat lock. Set combat lock.

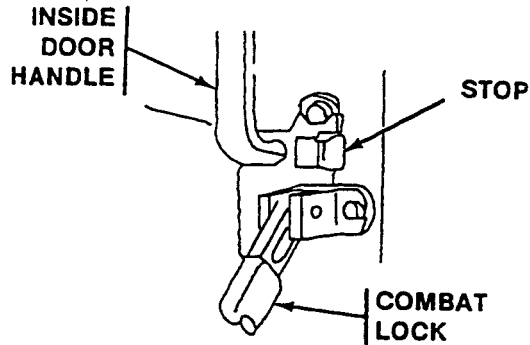

OPEN RAMP ACCESS DOOR FROM OUTSIDE CARRIER

WARNING

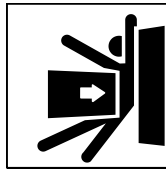

Ramp access door is heavy. It can swing and injure personnel. Do not stand behind ramp access door. Keep hands out from between handle and ramp access door.

NOTE

Combat lock must be released to open ramp access door from outside carrier.

1. Pull outside door handle up until ramp access door is released.

2. Swing ramp access door outward until ramp access door hook engages in door retainer.

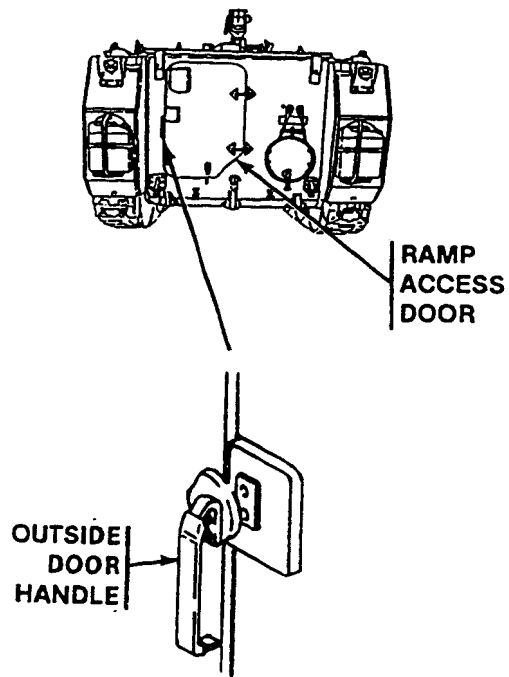

CLOSE RAMP ACCESS DOOR FROM OUTSIDE CARRIER

1. Pull ramp access door hook to release ramp access door.

- Swing ramp access door closed. Raise outside door handle to secure door closed.

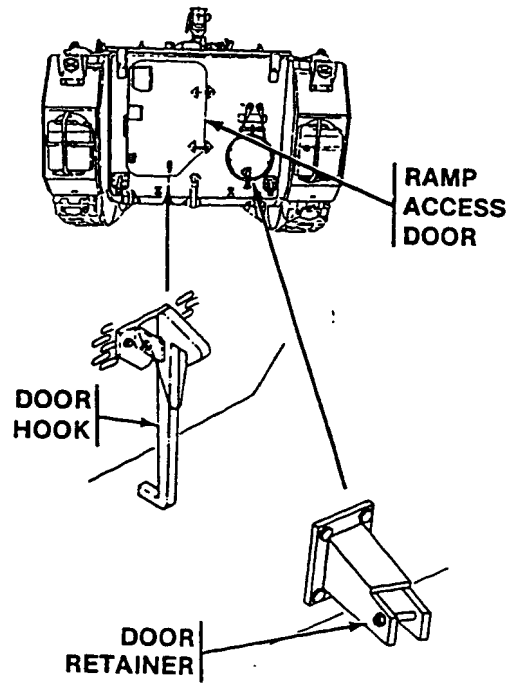

END OF TASK

**OPEN/CLOSE DRIVER'S HATCH COVER (M113A3, M1059A3, M1064A3,
AND M58 ONLY)**

0006 00

THIS WORK PACKAGE COVERS:

- Open Driver's Hatch Cover (page 0006 00-1).
 - Close Driver's Hatch Cover (page 0006 00-3).
-

INITIAL SETUP:

Maintenance Level

Operator

Personnel Required

Driver

Equipment Condition

- Carrier parked
 - Parking brake set (WP 0020 00)
-

OPEN DRIVER'S HATCH COVER

WARNING

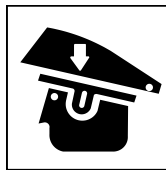

Driver's hatch cover could fall and injure you. Keep your head and hands clear when you open or close driver's hatch cover.

1. Lift inside handle to release driver's hatch cover.

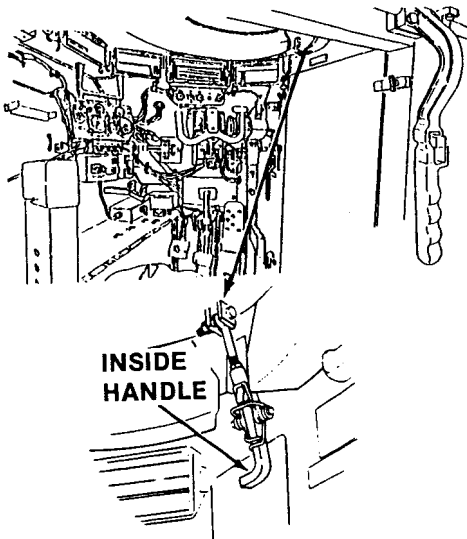

OPEN/CLOSE DRIVER'S HATCH COVER (M113A3, M1059A3, M1064A3, AND M58 ONLY)

— Continued

0006 00

2. Swing hatch cover open until it engages outside hook.
3. Install locking pin in outside hook to secure hatch cover in fully open position.

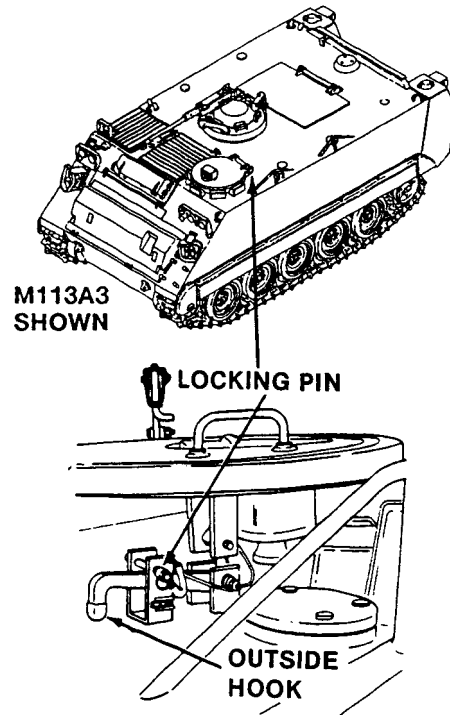

— Continued

CLOSE DRIVER'S HATCH COVER

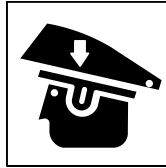
WARNING

Driver's hatch cover could fall and injure you. Keep your head and hands clear when you open or close driver's hatch cover.

1. Remove locking pin from outside hook. Place locking pin in spring clip.
2. Lift outside hook to release hatch cover from fully open position.

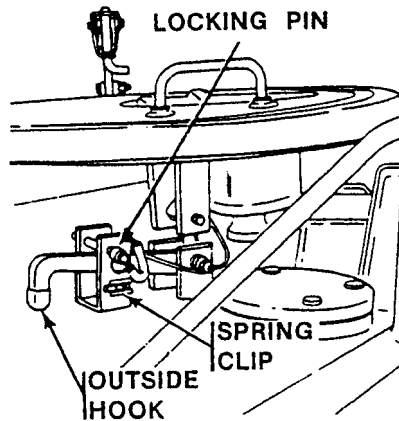

3. Swing hatch cover closed and secure with inside handle.

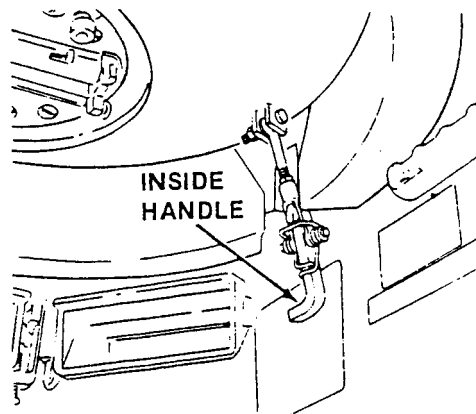

NOTE

Exterior wing nut may be used to secure hatch cover closed when carrier is not being operated.

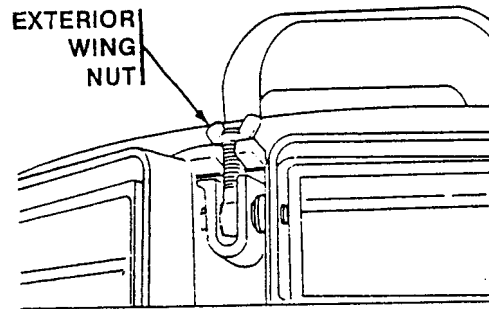

END OF TASK

OPEN/CLOSE CARGO HATCH COVER (M113A3 AND M1059A3 ONLY)

0008 00 ■

THIS WORK PACKAGE COVERS:

- Open Cargo Hatch Cover (page 0008 00-1).
- Close Cargo Hatch Cover (page 0008 00-2).

INITIAL SETUP:

Maintenance Level

Operator

Personnel Required

Soldier

OPEN CARGO HATCH COVER

WARNING



Cargo hatch cover is heavy. It can fall and injure you. When opening or closing cover, keep your head clear of the cover and keep your hands clear of the rim.

1. Pull chain to release cargo hatch cover.

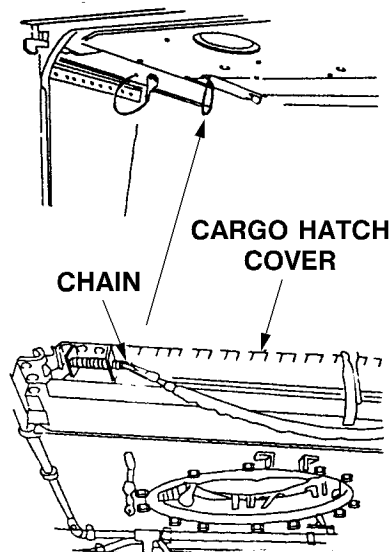

2. Swing hatch cover open until it engages in outside hook.

OPEN/CLOSE CARGO HATCH COVER (M113A3 AND M1059A3 ONLY)
 — Continued

0008 00

3. Install locking pin in outside hook to secure hatch cover in fully open position.

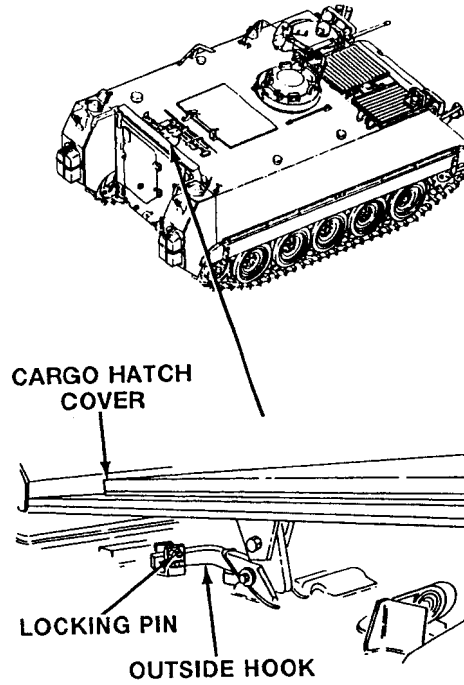

CLOSE CARGO HATCH COVER

WARNING

Cargo hatch cover is heavy. It can fall and injure you. When opening or closing cover, keep your head clear of the cover and keep your hands clear of the rim.

1. Remove locking pin from outside hook. Place locking pin in spring clip.
2. Lift outside hook to release hatch cover from fully open position.

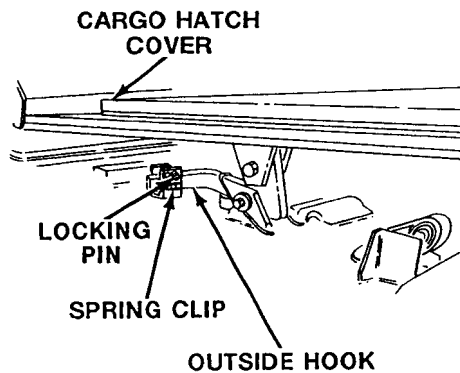

OPEN/CLOSE CARGO HATCH COVER (M113A3 AND M1059A3 ONLY)

— Continued

0008 00 ■

3. Swing hatch cover to closed position and pull strap until inside latch engages to secure hatch cover closed.

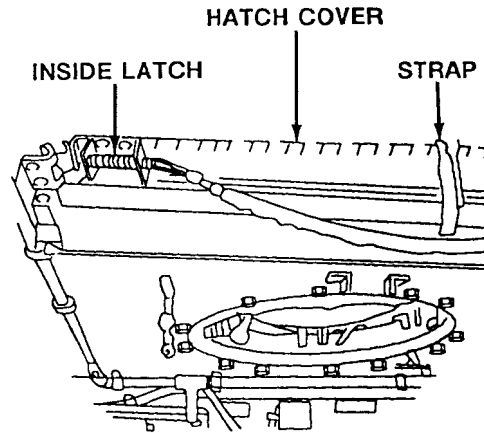

END OF TASK

OPEN/CLOSE COMMANDER'S HATCH COVER (M113A3, M1059A3, M1064A3, AND M58 ONLY)

0009 00

THIS WORK PACKAGE COVERS:

- Open Commander's Hatch Cover (page 0009 00-1).
- Close Commander's Hatch Cover (page 0009 00-2).

INITIAL SETUP:

Maintenance Level

Operator

Equipment Condition

Carrier stopped

Personnel Required

Soldier

OPEN COMMANDER'S HATCH COVER

WARNING

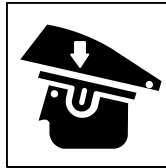

Commander's hatch cover could fall and injure you. Keep hands clear when you open or close commander's hatch cover.

1. Press inside latch to release commander's hatch cover.

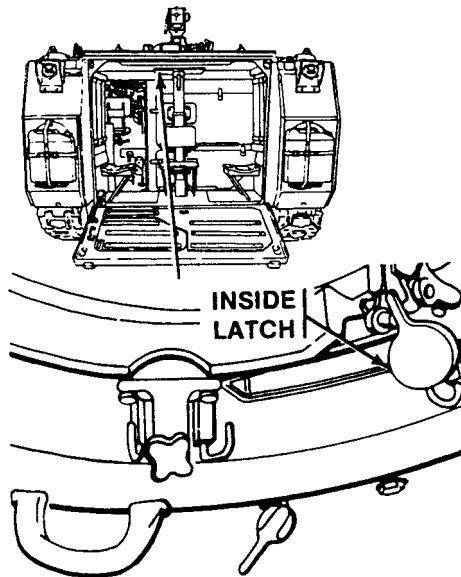

2. Swing hatch cover open until it engages outside hook.

OPEN/CLOSE COMMANDER'S HATCH COVER (M113A3, M1059A3, M1064A3, AND M58 ONLY) — Continued

0009 00

3. Install locking pin in outside hook to secure hatch cover in fully open position.

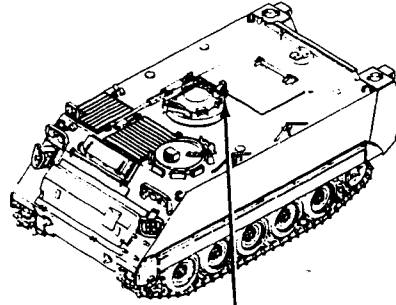

M113A3 SHOWN

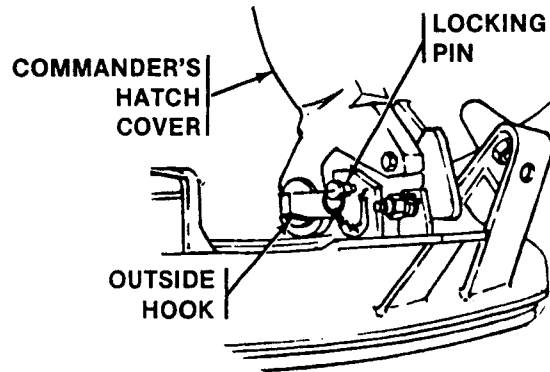

CLOSE COMMANDER'S HATCH COVER



Commander's hatch cover could fall and injure you. Keep hands clear when you open or close commander's hatch cover.

1. Remove locking pin from outside hook.

OPEN/CLOSE COMMANDER'S HATCH COVER (M113A3, M1059A3, M1064A3, AND M58 ONLY) — Continued

0009 00

2. Lift outside hook to release hatch cover from fully open position.

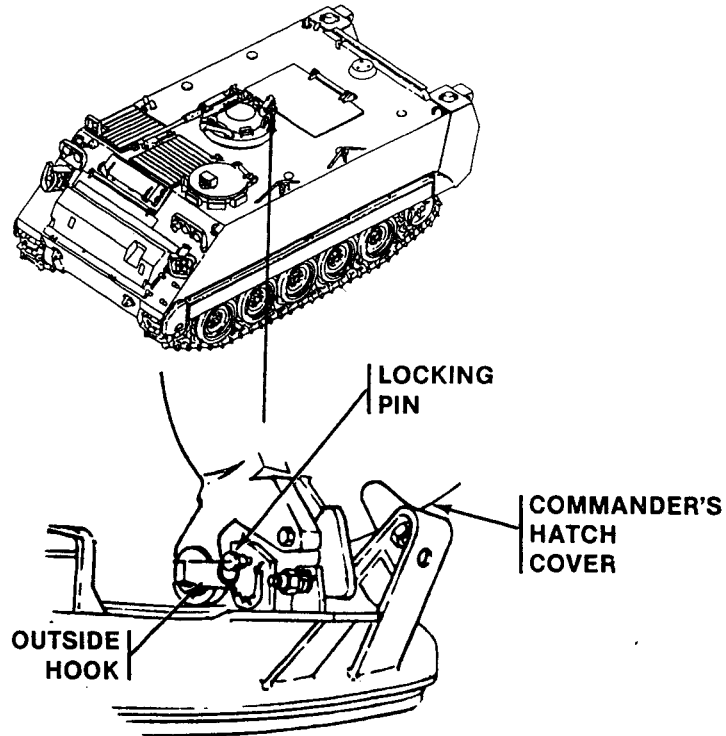

3. Swing hatch cover closed and secure with inside latch.

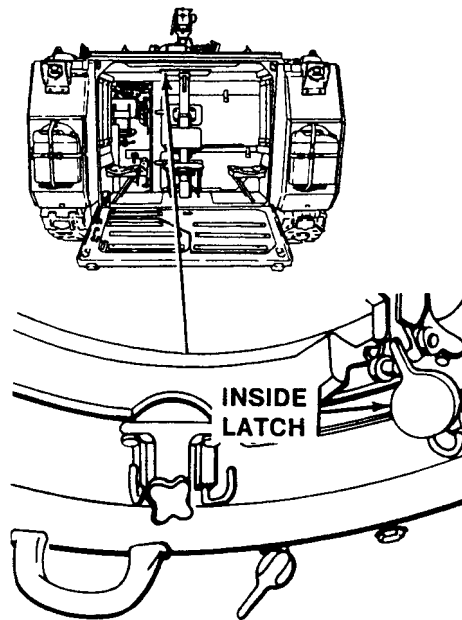

END OF TASK

OPERATE COMMANDER'S CUPOLA (M113A3, M1059A3, M1064A3, AND M58 ONLY)

0010 00

THIS WORK PACKAGE COVERS:

Operate Commander's Cupola (page 0010 00-1).

INITIAL SETUP:

Maintenance Level

Operator

Equipment Condition

Commander's hatch open (WP 0009 00)

Personnel Required

Commander

OPERATE COMMANDER'S CUPOLA

1. Turn azimuth lock handle straight down to allow cupola to rotate.
2. Rotate cupola to aim machine gun.
3. Turn drag brake knob to the right to slow cupola movement.
4. Turn azimuth lock handle to lock position to lock cupola at desired position.

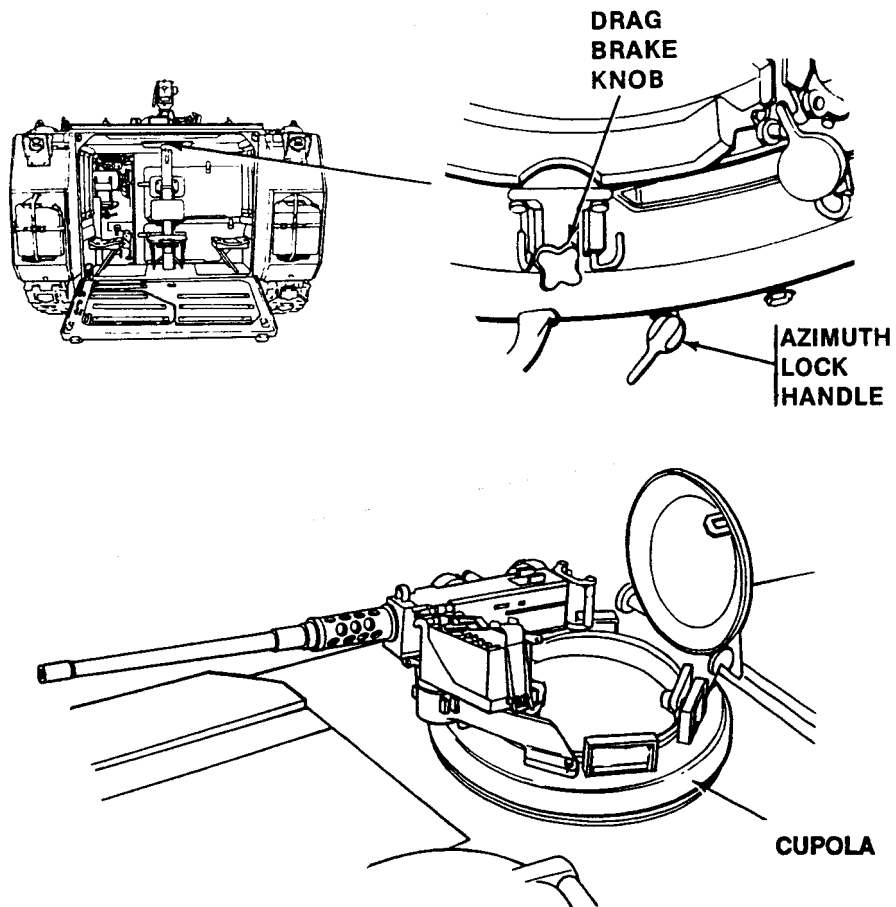

END OF TASK

OPEN/CLOSE POWER PLANT ACCESS DOOR

0011 00

THIS WORK PACKAGE COVERS:

Open Power Plant Access Door (page 0011 00-1).
Close Power Plant Access Door (page 0011 00-3).

INITIAL SETUP:

Maintenance Level

Operator

Personnel Required

Soldier

Equipment Condition

Engine stopped (WP 0023 00)

Trim vane lowered (WP 0039 00)

OPEN POWER PLANT ACCESS DOOR

WARNING



Power plant access door could fall and injure you. Install door brace before you work under door.

1. Release combat lock handle to unlock power plant access door.

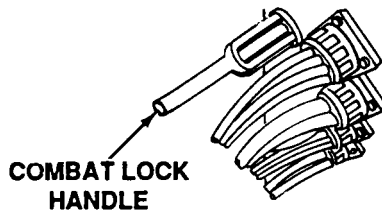
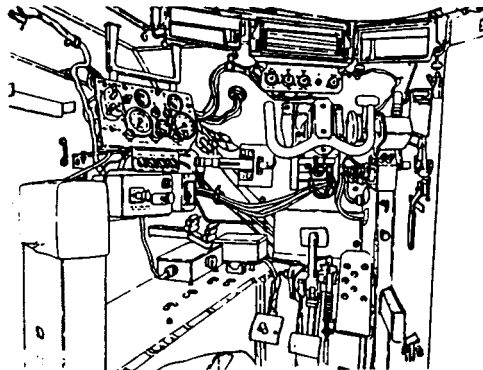

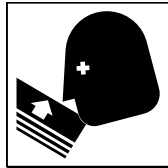
WARNING

Power plant access door may spring open. Soldiers can be injured. When opening, stay out of door path.

2. Turn handle to the right, and raise power plant access door.
3. Place end of door brace in hole in door frame to secure power plant access door open.

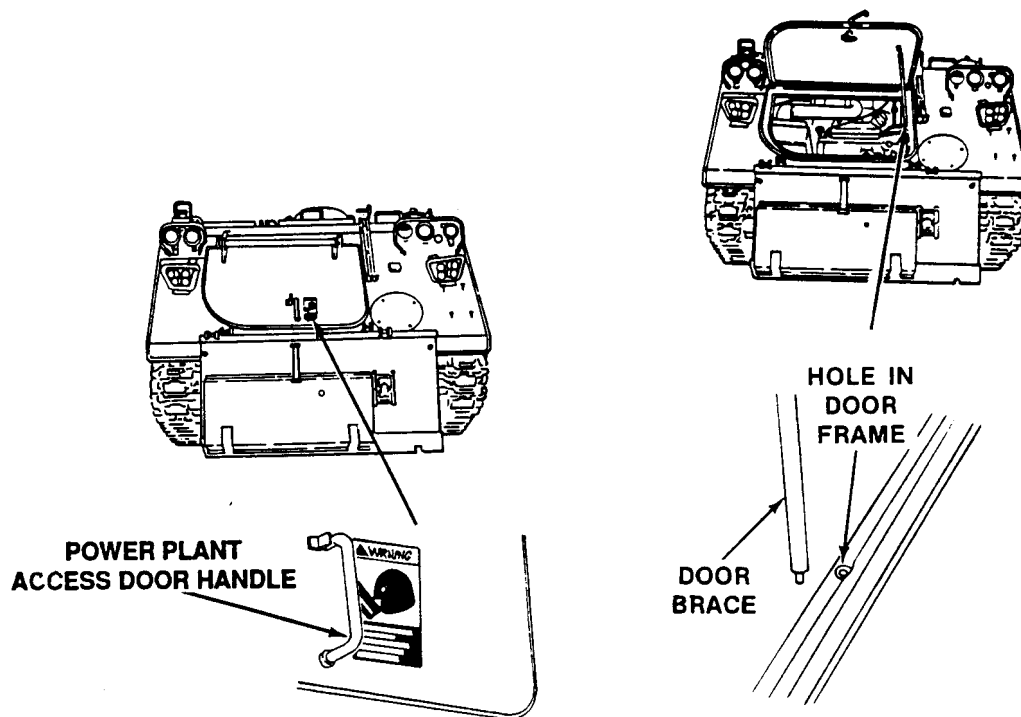

CLOSE POWER PLANT ACCESS DOOR

1. Raise power plant access door to remove brace from hole in door frame. Stow brace in clip on door.
2. Lower power plant access door to closed position and secure with handle.

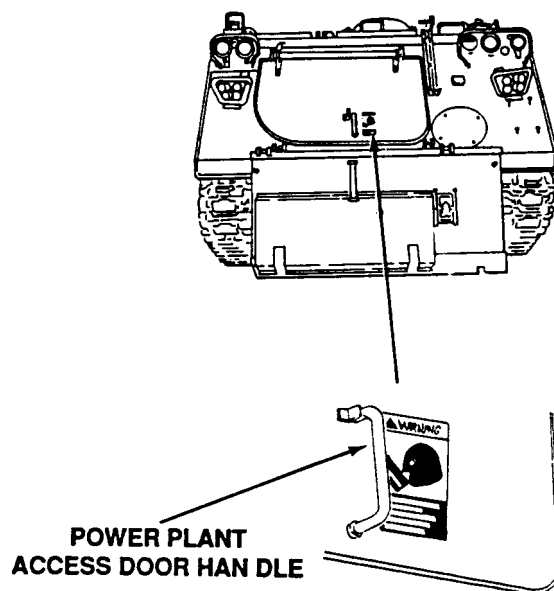

3. Rotate combat lock handle to lock power plant access door.

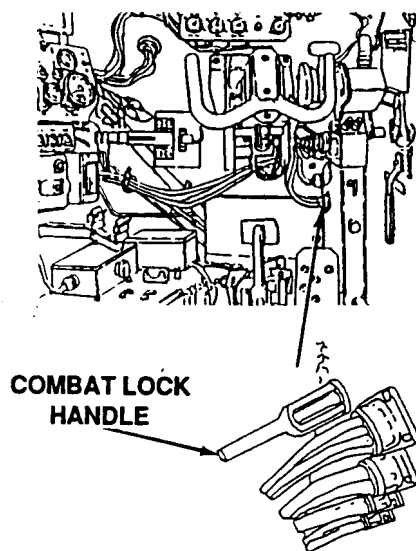

4. Stow trim vane. See task: LOWER/STOW TRIM VANE (WP 0039 00).

END OF TASK

LOWER/RAISE RAMP

0012 00

THIS WORK PACKAGE COVERS:

Lower Ramp (page 0012 00-1).
 Raise Ramp (page 0012 00-2).

INITIAL SETUP:

Maintenance Level

Operator

Personnel Required

Driver

Equipment Condition

Carrier parked

Engine started (WP 0021 00)

Ramp access door closed (WP 0005 00)

LOWER RAMP

WARNING

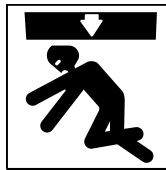

Lowering ramp could injure personnel. Make sure no one is in ramp zone before you lower ramp.

Check ramp door operation. Make sure hinges work right and door can be secured tightly with lock.

Check ramp operations by opening and lowering.

Unlocked ramp can fall open suddenly. Personnel can be killed or injured. Check that ramp cable is connected with no slack. Ramp system and hull can get damaged if ramp unlocks when carrier is in operation. Do not operate carrier if locks do not secure ramp properly. Keep away from ramps that have come open during carrier operation.

1. Push ramp lock release button and move ramp locking handle to the rear as far as it will go.
2. Push ramp control handle forward to lower ramp. The farther you push the faster the ramp will drop.

3. Release ramp control handle to stop ramp.

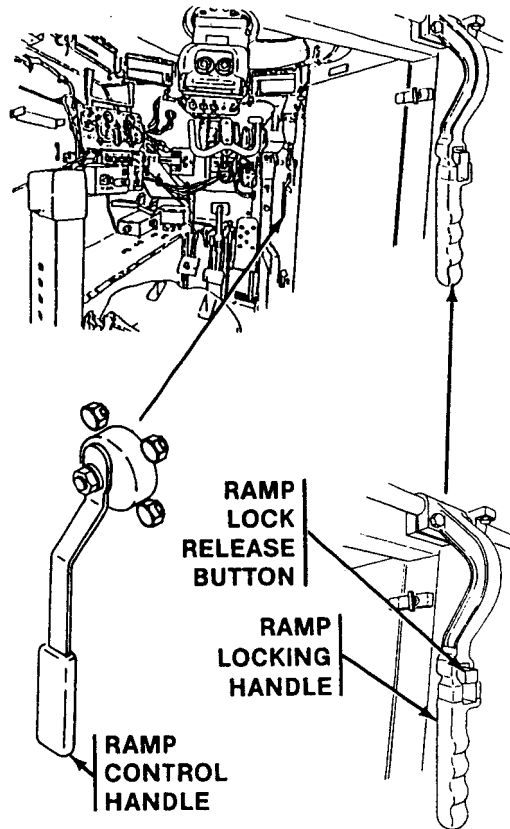

RAISE RAMP

NOTE

Ramp may be lowered with the engine started or with the engine stopped and MASTER SWITCH ON. Engine must be started to raise ramp. Sound horn before lowering ramp if tactical situation permits.

NOTE

Horn should be sounded before raising ramp if tactical situation permits.

1. Move ramp locking handle to the rear as far as it will go.
2. Increase engine speed to 1200 rpm.
3. Pull ramp control handle to the rear and hold it until ramp is closed.

4. Push ramp locking handle forward until it locks in place.

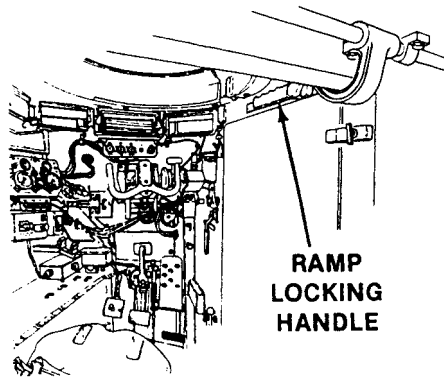

END OF TASK

ADJUST DRIVER'S SEAT

0013 00

THIS WORK PACKAGE COVERS:

Raise or Lower Driver's Seat (page 0013 00-1).
Move Driver's Seat to Front or Rear (page 0013 00-3).

INITIAL SETUP:

Maintenance Level

Operator

Equipment Condition

Carrier stopped

Personnel Required

Driver

RAISE OR LOWER DRIVER'S SEAT

WARNING



Do not step on service brake while entering and exiting carrier. Failure to do so could cause personnel inside and outside the carrier to get injured or killed.

WARNING



Seat can spring up and hit you when vertical control handle is released. Make sure you are sitting in the seat before releasing vertical control handle.

CAUTION

Do not step on seat back when entering or exiting vehicle. Damage to the seat back will result.

1. Sit in driver's seat.
2. Pull up vertical control handle and let your weight control the up and down movement of the seat.
3. When positioned, release vertical control handle to lock seat in place.

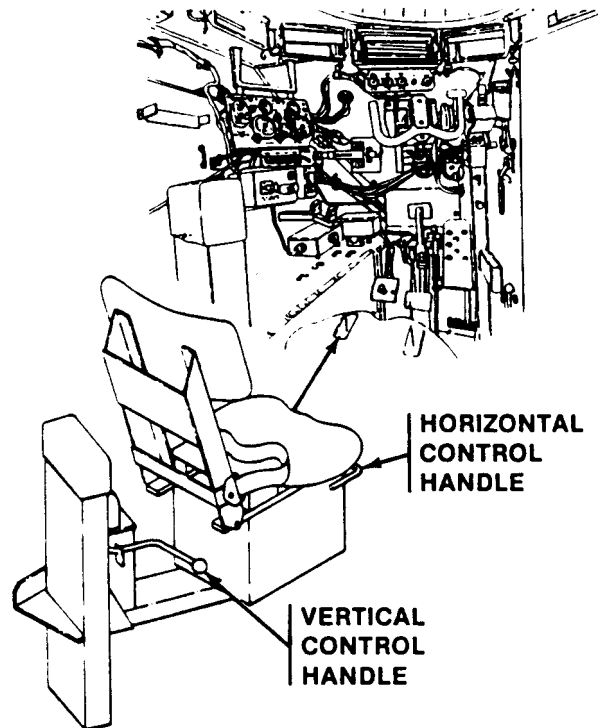

MOVE DRIVER'S SEAT TO FRONT OR REAR

1. Pull up horizontal control handle and move driver's seat to front or rear.
2. When positioned, release horizontal control handle to lock seat in place.

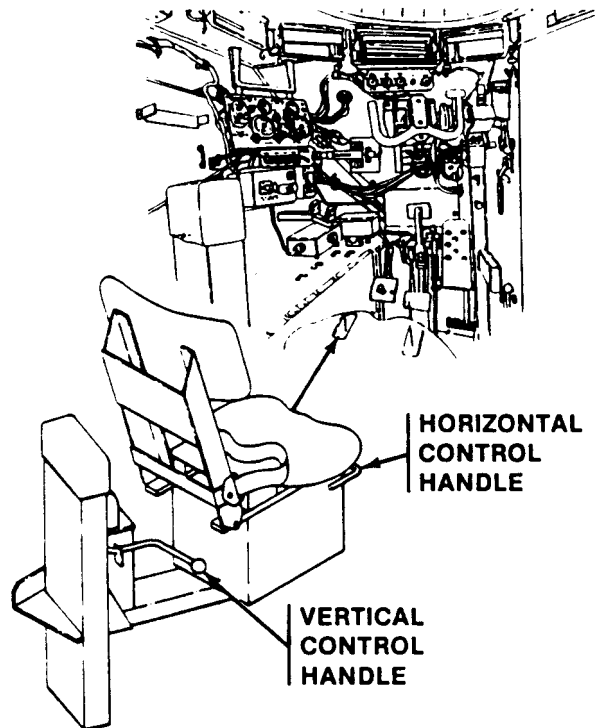
**END OF TASK**

ADJUST DRIVER'S LAP SEAT BELT AND SHOULDER HARNESS

0014 00

THIS WORK PACKAGE COVERS:

Adjust Driver's Lap Seat Belt and Shoulder Harness (page 0014 00-1).

INITIAL SETUP:

Maintenance Level

Operator

Equipment Condition

Carrier stopped

Personnel Required

Driver

ADJUST DRIVER'S LAP SEAT BELT AND SHOULDER HARNESS

WARNING



Sudden carrier movement can throw you out of your seat. Wear seat belt while carrier is in motion. Do not use seat with missing or inoperative seat belt.

NOTE

If seat is not equipped with a shoulder harness, do Step 1, Step 2, and Step 5 only.

ADJUST DRIVER'S LAP SEAT BELT AND SHOULDER HARNESS — Continued

0014 00

1. Sit in driver's seat.
2. Adjust lap seat belt so lap buckle is centered on your lap.
3. Position shoulder harness over your shoulders.
4. Insert lap seat belt tongue through left and right shoulder harness ends.
5. Fasten lap seat belt.
6. Adjust shoulder harness using shoulder harness adjusters as needed.

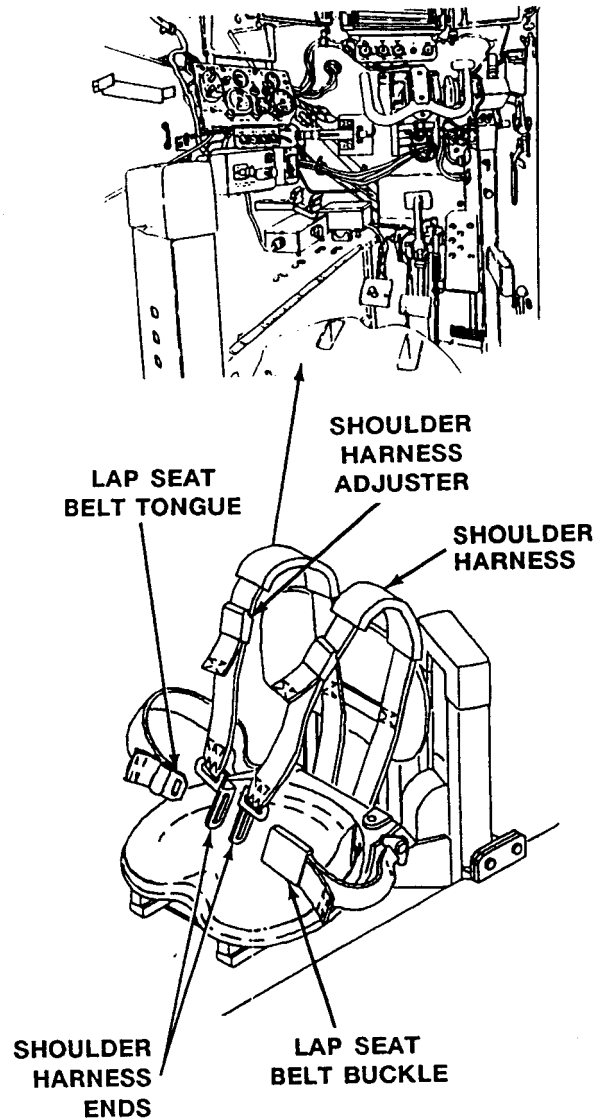
**END OF TASK**

ADJUST COMMANDER'S SEAT (M113A3, M1059A3, M1064A3, AND M58 ONLY)

0015 00

THIS WORK PACKAGE COVERS:

Adjust Commander's Seat (page 0015 00-1).

INITIAL SETUP:

Maintenance Level

Operator

Equipment Condition

Carrier stopped

Personnel Required

Soldier

ADJUST COMMANDER'S SEAT

1. Push in vertical control handle and raise or lower commander's seat.
2. When positioned, release vertical control handle to lock commander's seat in place.

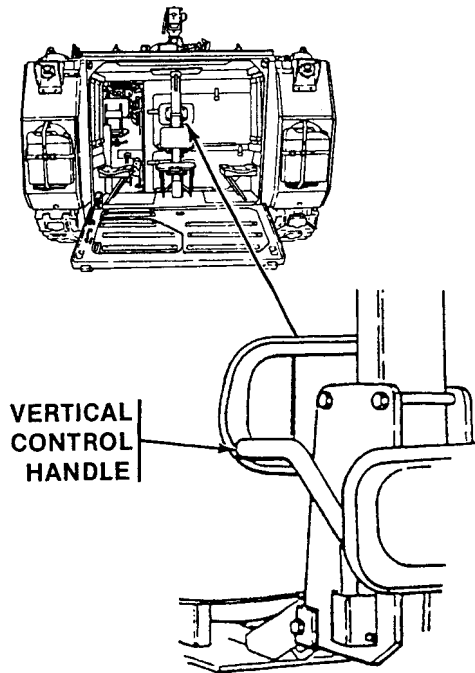

END OF TASK

**STOW/UNSTOW COMMANDER'S SEAT (M113A3, M1059A3, M1064A3,
AND M58 ONLY)**

0016 00

THIS WORK PACKAGE COVERS:

Stow Commander's Seat (page 0016 00-1).
Unstow Commander's Seat (page 0016 00-2).

INITIAL SETUP:

Maintenance Level

Operator

Equipment Condition

Carrier stopped

Personnel Required

Soldier

STOW COMMANDER'S SEAT

1. Lift commander's seat toward seat support until it locks in stowed position.

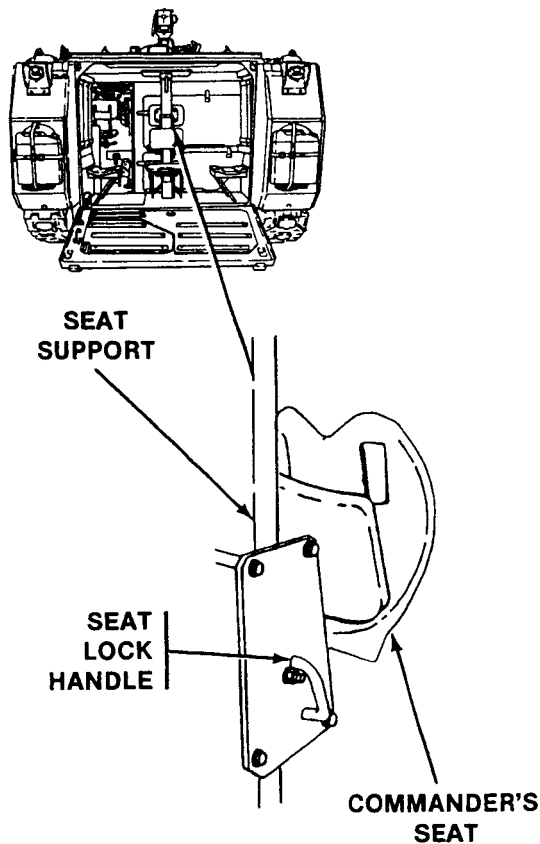

STOW/UNSTOW COMMANDER'S SEAT (M113A3, M1059A3, M1064A3, AND M58 ONLY)
— Continued

0016 00

UNSTOW COMMANDER'S SEAT

1. Pull seat lock handle forward to release commander's seat from stowed position. Lower seat until it locks in down position.

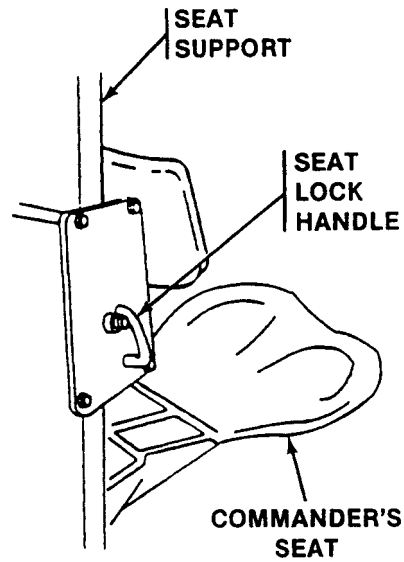
**END OF TASK**

STOW/UNSTOW JUMP SEAT (M113A3 AND M1059A3)

0017 00

THIS WORK PACKAGE COVERS:

Stow Jump Seat (page 0017 00-1).
Unstow Jump Seat (page 0017 00-2).

INITIAL SETUP:

Maintenance Level

Operator

Equipment Condition

Carrier stopped

Personnel Required

Soldier

STOW JUMP SEAT

1. Pull jump seat up towards seat support until it locks in stowed position.

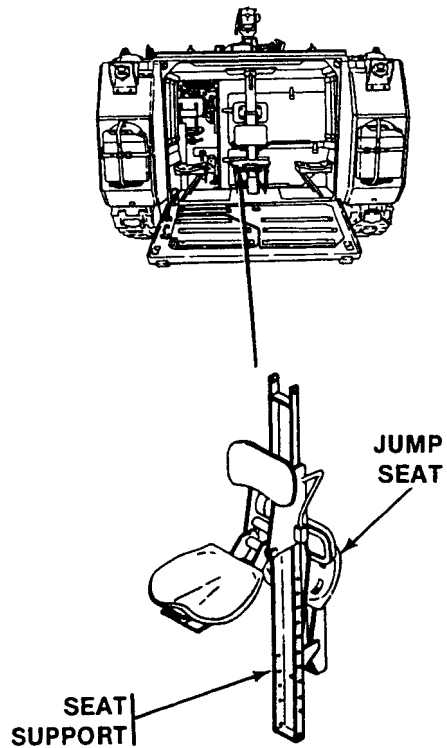

UNSTOW JUMP SEAT

1. Pull jump seat up and to the rear to release seat from stowed position. Lower seat to down position.

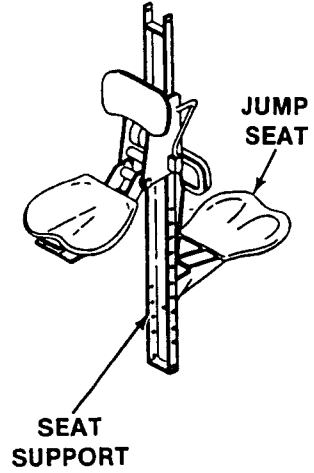
**END OF TASK**

CONNECT CVC HELMET TO INTERCOM CONTROL BOX

0018 00

THIS WORK PACKAGE COVERS:

Connect CVC Helmet to Intercom Control Box (page 0018 00-1).

INITIAL SETUP:

Maintenance Level

Operator

Personnel Required

Driver

Commander

References

TM 11-5820-498-12

TM 11-5915-224-14

CONNECT CVC HELMET TO INTERCOM CONTROL BOX

NOTE

Procedure is the same at both driver's and commander's station.

1. Connect helmet cord to quick disconnect plug.

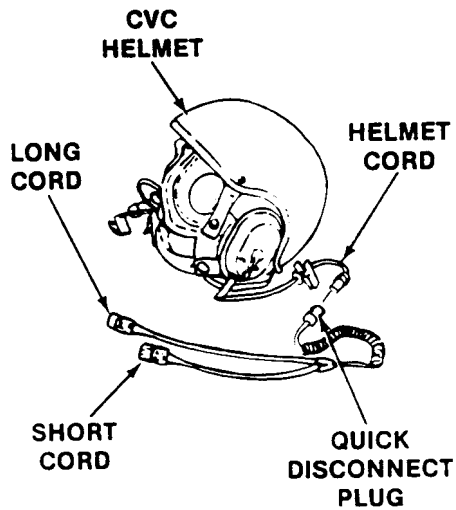

CONNECT CVC HELMET TO INTERCOM CONTROL BOX — Continued

0018 00

2. Connect long cord to INT jack on intercom control box.
3. Connect short cord to RAD jack on intercom control box.

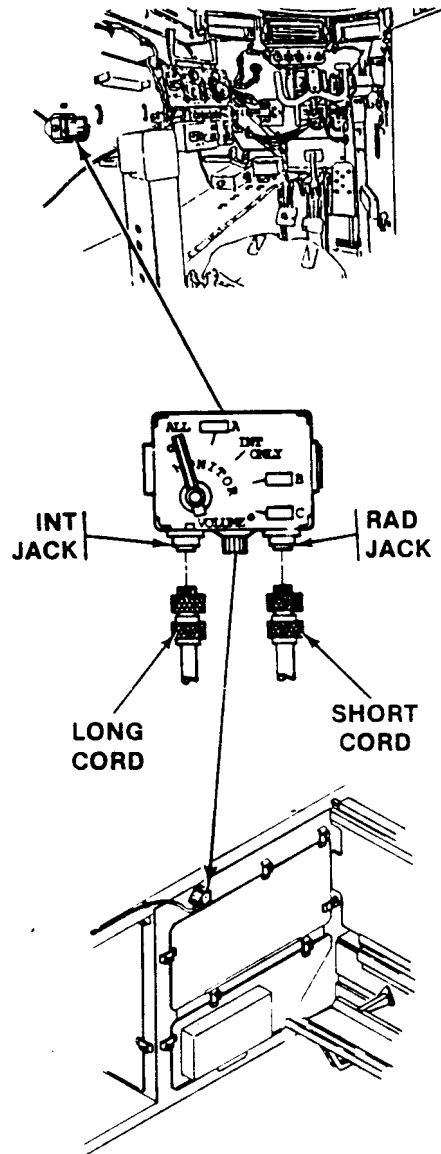

NOTE

See TM 11-5820-498-12 for more information on radio equipment.
See TM 11-5915-224-14 for operation of electrical transient suppressor.

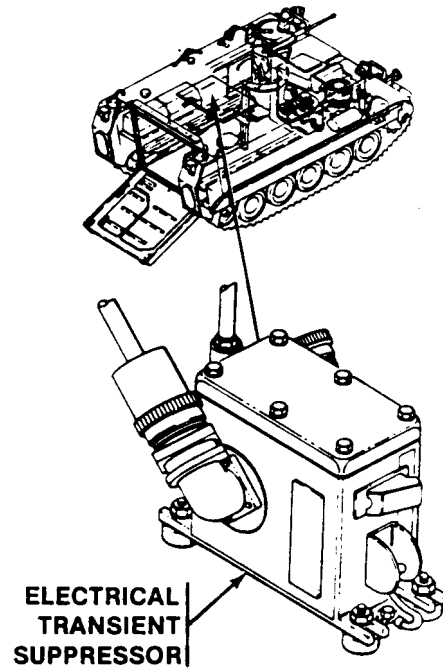

END OF TASK

CONNECT CVC HELMET TO VEHICLE INTERCOMMUNICATIONS SYSTEM (VIS)

0019 00

THIS WORK PACKAGE COVERS:

Connect CVC Helmet to Vehicle Intercommunications System (VIS) (page 0019 00-1).

INITIAL SETUP:

Maintenance Level

Operator

References

TM 11-5820-890-10-1

SB 11-131

Personnel Required

Driver

Commander

CONNECT CVC HELMET TO VEHICLE INTERCOMMUNICATIONS SYSTEM (VIS)

NOTE

Procedure is the same at both driver's and commander's station.

1. Connect helmet cord to quick disconnect plug.

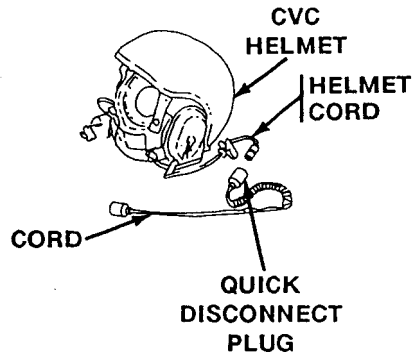

CONNECT CVC HELMET TO VEHICLE INTERCOMMUNICATIONS SYSTEM (VIS) —
Continued

0019 00

2. Connect cord to left jack on intercom control box.

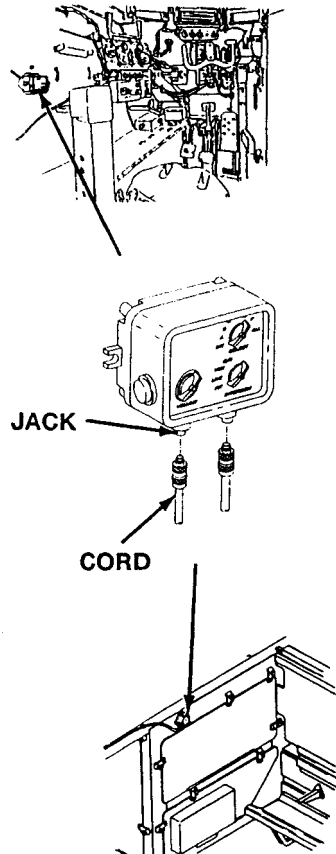
**NOTE**

For applicable vehicle radio sets and authorized installations, refer to SB 11-131. See TM 11-5820-890-10-1 for references for radio operation.

END OF TASK

SET/RELEASE PARKING BRAKE

0020 00

THIS WORK PACKAGE COVERS:

Set Parking Brake (page 0020 00-1).
 Release Parking Brake (page 0020 00-2).

INITIAL SETUP:

Maintenance Level

Operator

Equipment Condition

Carrier stopped

Personnel Required

Driver

SET PARKING BRAKE

1. Depress and hold brake pedal.
2. Pull up on parking brake handle to set parking brake.
3. Release brake pedal.

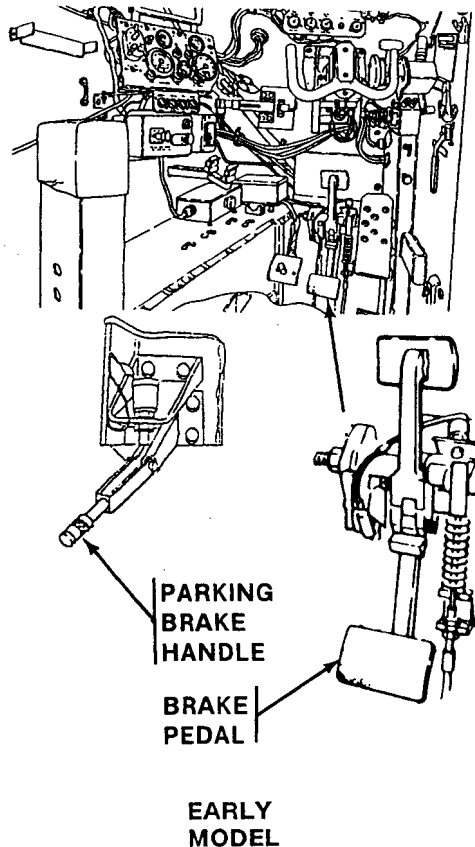

RELEASE PARKING BRAKE

WARNING

Do not step on parking brake handle when entering or leaving a running vehicle. The vehicle may pivot and cause injury or death.

1. Depress and hold brake pedal.
2. Push down on parking brake handle to release parking brake.
3. Let up on brake pedal.

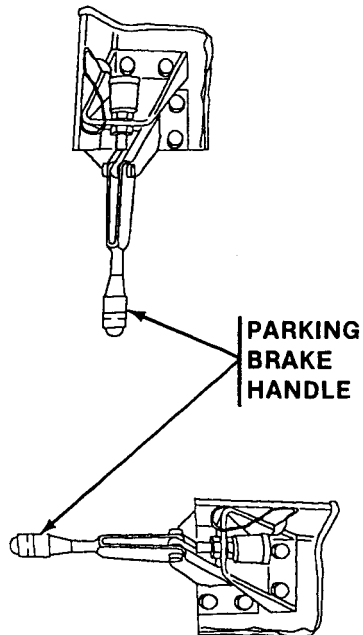

**LATE
MODEL**

END OF TASK

START ENGINE

0021 00

THIS WORK PACKAGE COVERS:

- Prepare to Start Engine (page 0021 00-1).
 - Start Engine (above +40°F (+4°C)) (page 0021 00-8).
 - Start Engine (-25° to +40°F) (-32° to +4°C) (page 0021 00-10).
-

INITIAL SETUP:

Maintenance Level

Operator

Personnel Required

Driver

References

TM 11-5820-498-12

WP 0018 00

WP 0020 00

WP 0040 00

Equipment Condition

Engine stopped (WP 0024 00)

PREPARE TO START ENGINE

WARNING



Engine exhaust gas is deadly poison. Make sure power plant access panels are closed tight before you start engine.

CAUTION

Do not operate vehicle while both fuel return lines are closed. Engine damage will result.

1. Check that power plant compartment access panels are closed tight (WP 0040 00).

WARNING

Sudden carrier movement can throw you out of your seat. Wear seat belt while carrier is in motion. Do not use seat with missing or inoperative seat belt.

2. Position shoulder harness over your shoulders. Adjust lap seat belt. Insert lap seat belt tongue through left and right shoulder harness ends and fasten lap seat belt. Adjust shoulder harness fit.

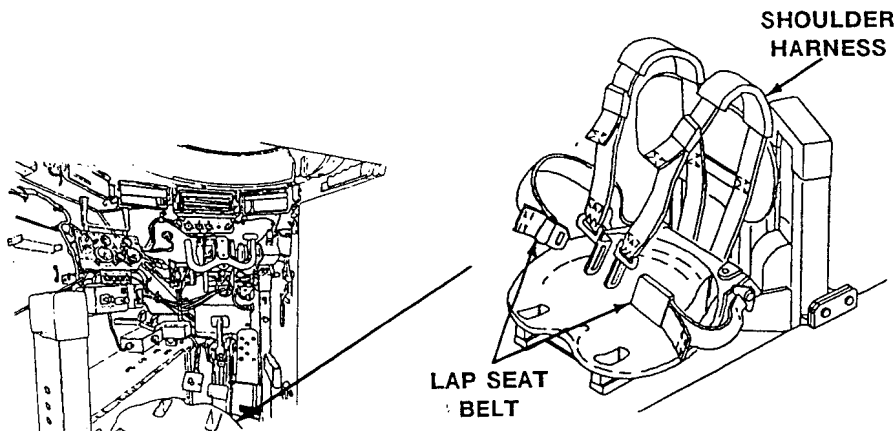

3. Check that parking brake is set (WP 0020 00).

WARNING

Noise levels in carrier could damage hearing. Wear ear protection. Read warning in front of this manual.

CAUTION

During engine start, damage to radio components can occur. Make sure that radio power switch is OFF before starting engine. See TM 11-5820-498-12.

4. Put on CVC helmet and connect to intercom control box (WP 0018 00).

WARNING

If transmission controller is set to SL position, and steering wheel is not centered to engage locking pin, carrier may pivot steer and injure personnel. Steering wheel must be centered when starting engine.

5. Center steering wheel and place transmission controller in SL position to lock steering wheel.

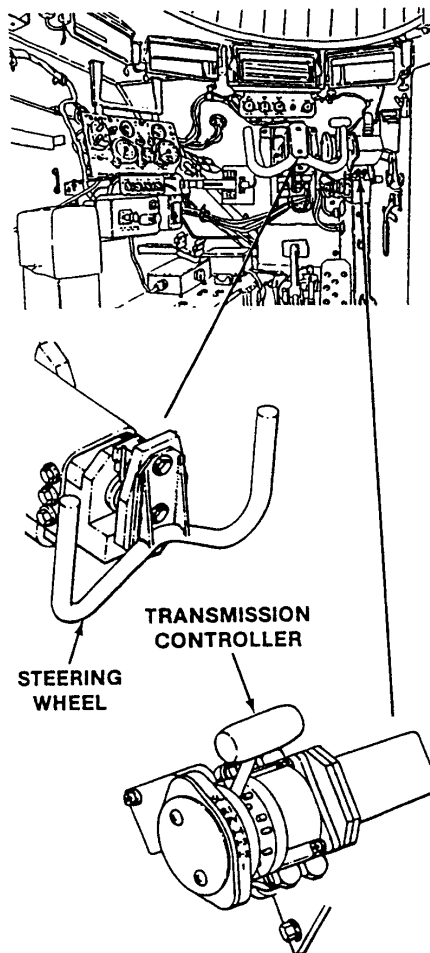

START ENGINE — Continued

0021 00

6. Turn MASTER SWITCH ON.

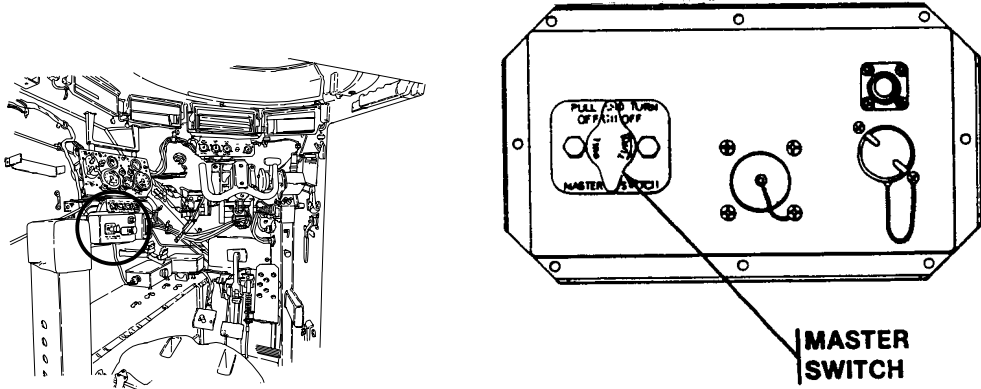

7. Check that MASTER SWITCH ON indicator light is on.

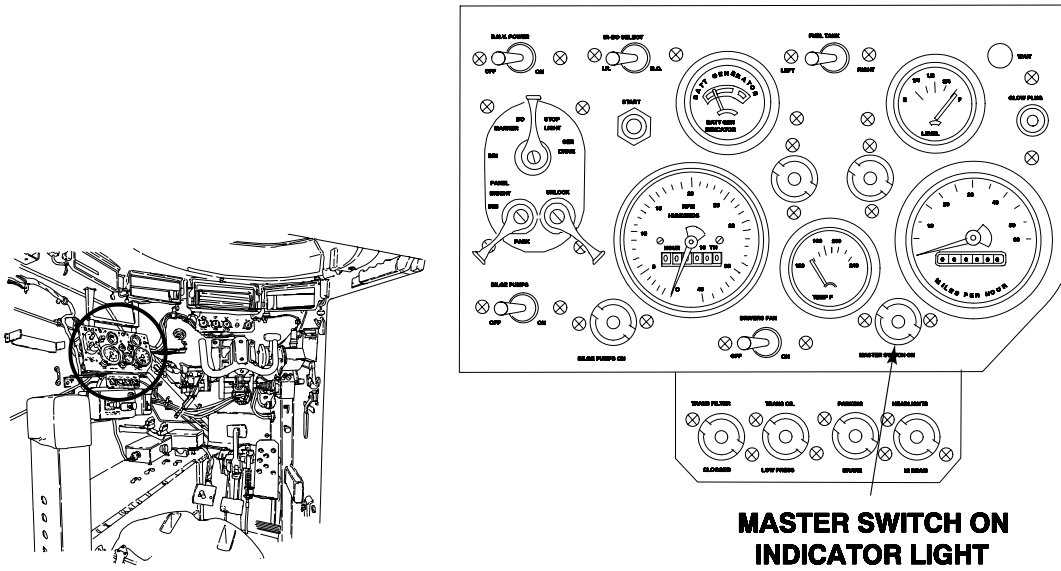

START ENGINE — Continued

0021 00

8. Check that STEERING LOCKED indicator light is on.

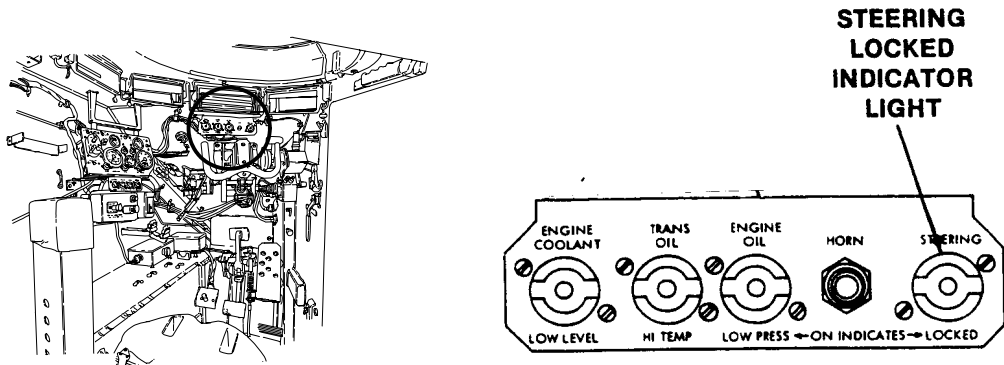

9. Check that PARKING BRAKE indicator light is on.
10. Check that BATT GEN indicator points to yellow zone.

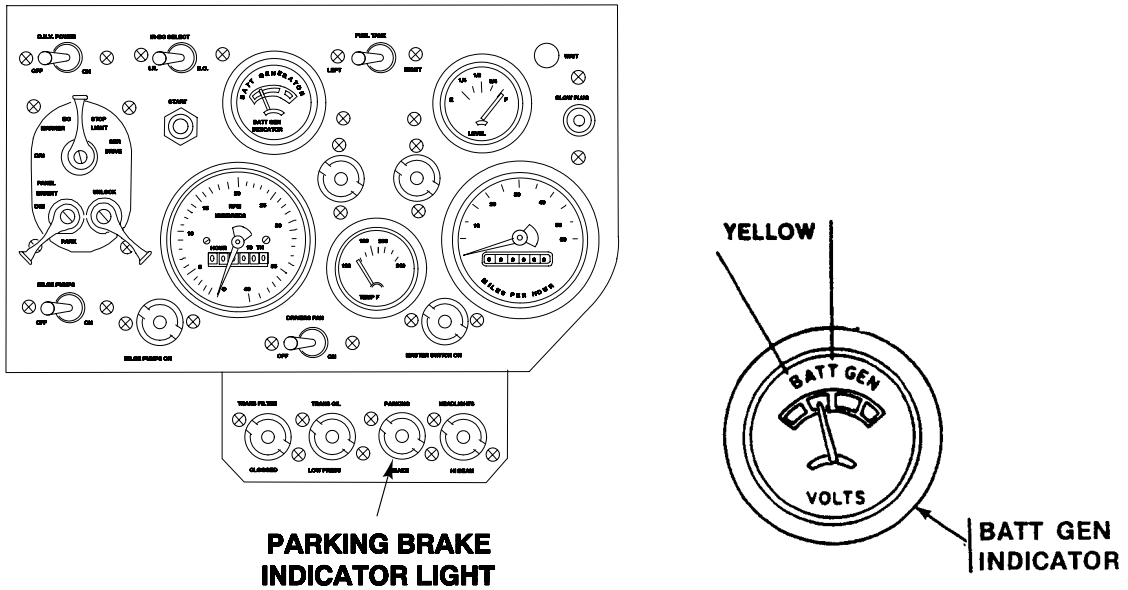

11. Check that FUEL LEVEL gauge indicates amount of fuel in fuel tanks.

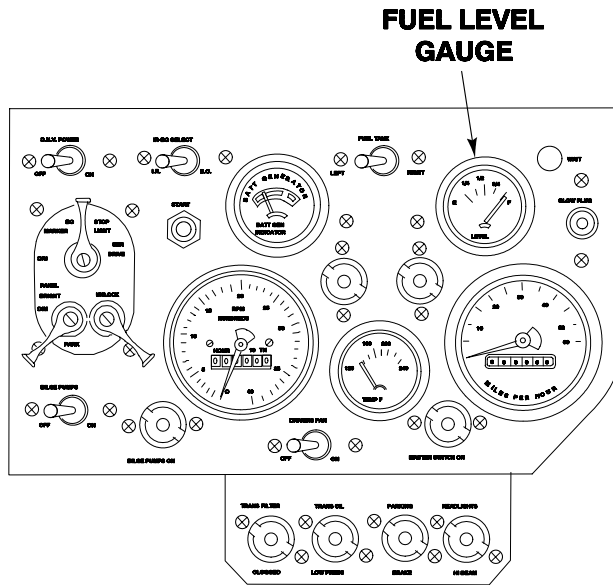

12. Check that ENGINE OIL LOW PRESS warning light is on.
13. Check that ENGINE COOLANT LOW LEVEL warning light is not on.

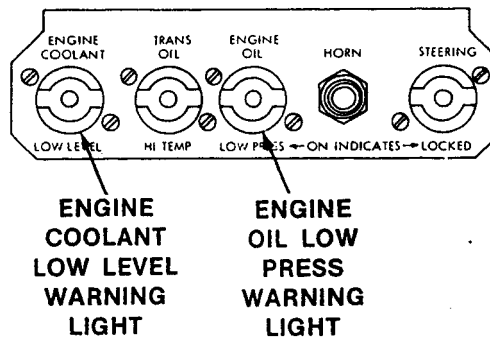

14. Check that tow start handle is pushed in all the way.

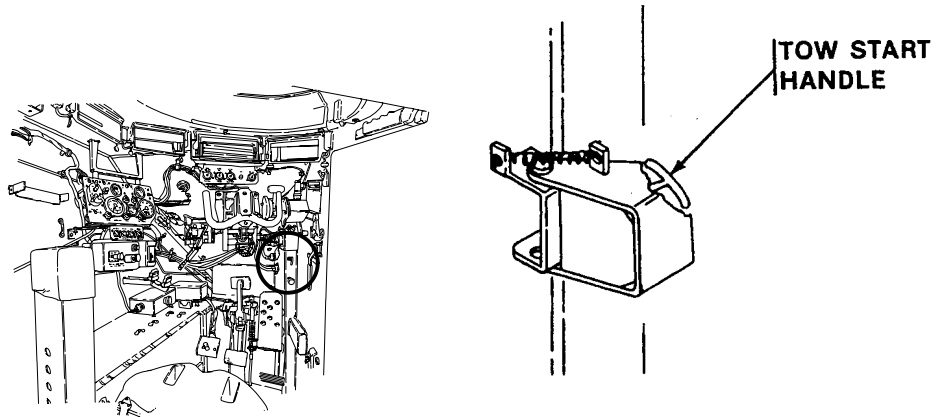

15. Push in fuel cutoff control.

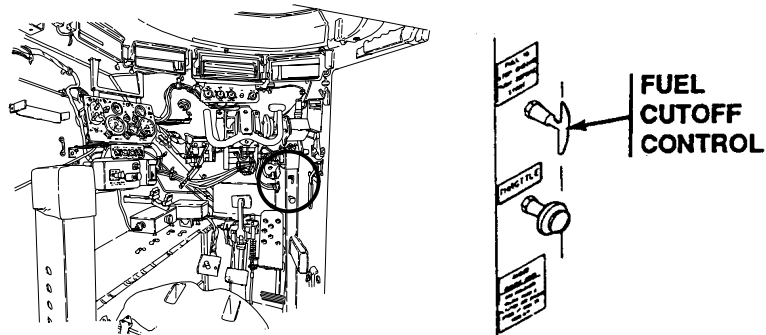

NOTE

See following procedure to start engine when air temperature is above +40° F (+4° C). Go to page 0021 00-10 for procedure to start engine when air temperature is -25° to +40° F (-32° to +4° C).

START ENGINE (ABOVE +40° F (+4° C))

NOTE

If tactical situation permits, horn should be sounded to warn personnel that engine is about to be started.

1. Press HORN switch.

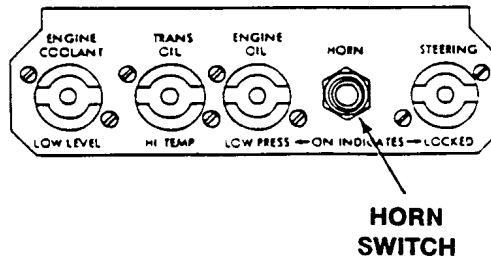

CAUTION

Pressing START switch for more than 15 seconds at temperatures above +40° F (+4° C) can damage starter. Do not press START switch for more than 15 seconds at a time. If engine does not start on first try, wait at least 30 seconds and try again.

2. Press START switch and hold until engine starts, but no longer than 15 seconds.

START SWITCH

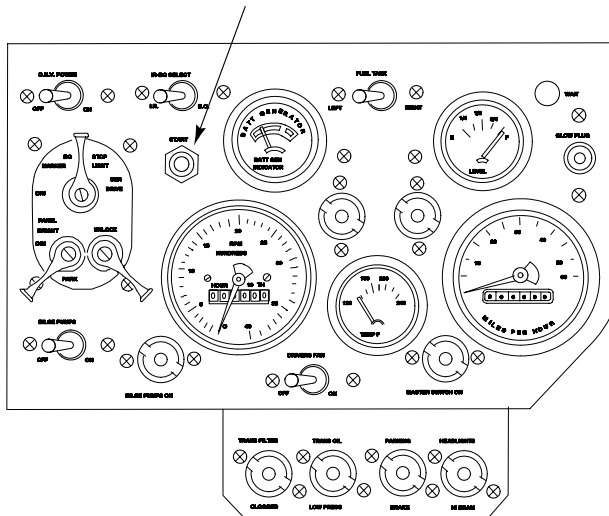

3. If engine does not start on first try, wait 30 seconds and try again. If engine does not start after three times, notify unit maintenance.

4. Check that ENGINE OIL LOW PRESS warning light goes off within 10 seconds after engine starts.

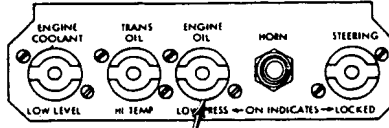

ENGINE OIL LOW PRESS WARNING LIGHT

5. Check that BATT GEN indicator points to green zone.

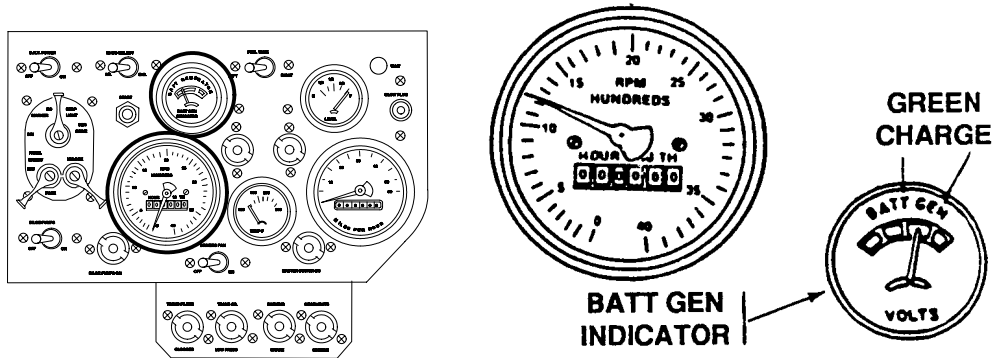

BATT GEN INDICATOR

6. Run engine at 1000-1200 RPM for 3-5 minutes.
7. Reduce engine to idle speed (650-700 RPM).

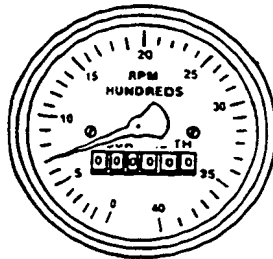

IDLE RPM

START ENGINE (-25° to +40° F) (-32° to +4° C)

NOTE

If temperature is below -25° F (-32° C) and engine coolant heater was used to warm coolant prior to engine start procedures, shut down engine coolant heater (WP 0062 00).

If tactical situation permits, horn should be sounded to warn personnel that engine is about to be started.

1. Turn MASTER POWER switch ON.
2. Check that MASTER POWER indicator switch is ON.
3. Push FUEL SHUTOFF CONTROL in.

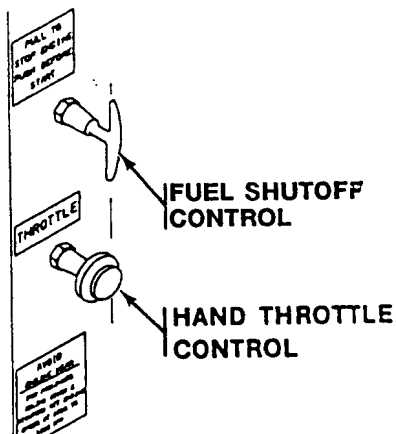

4. Press HORN switch.

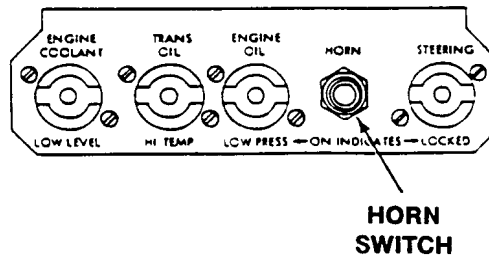

NOTE

Step 5 refers to all vehicles.

5. Check instrument panel and warning lights panel for unusual readings. Indicators should read as follows:
 MASTER SWITCH ON light - ON
 ENGINE OIL warning light - ON
 VOLTAGE METER - needle in green or yellow zone
 FUEL LEVEL indicator - indicates amount of fuel in right or left fuel tank, depending on setting of FUEL TANK switch.
 All other lights and indicators should be off.

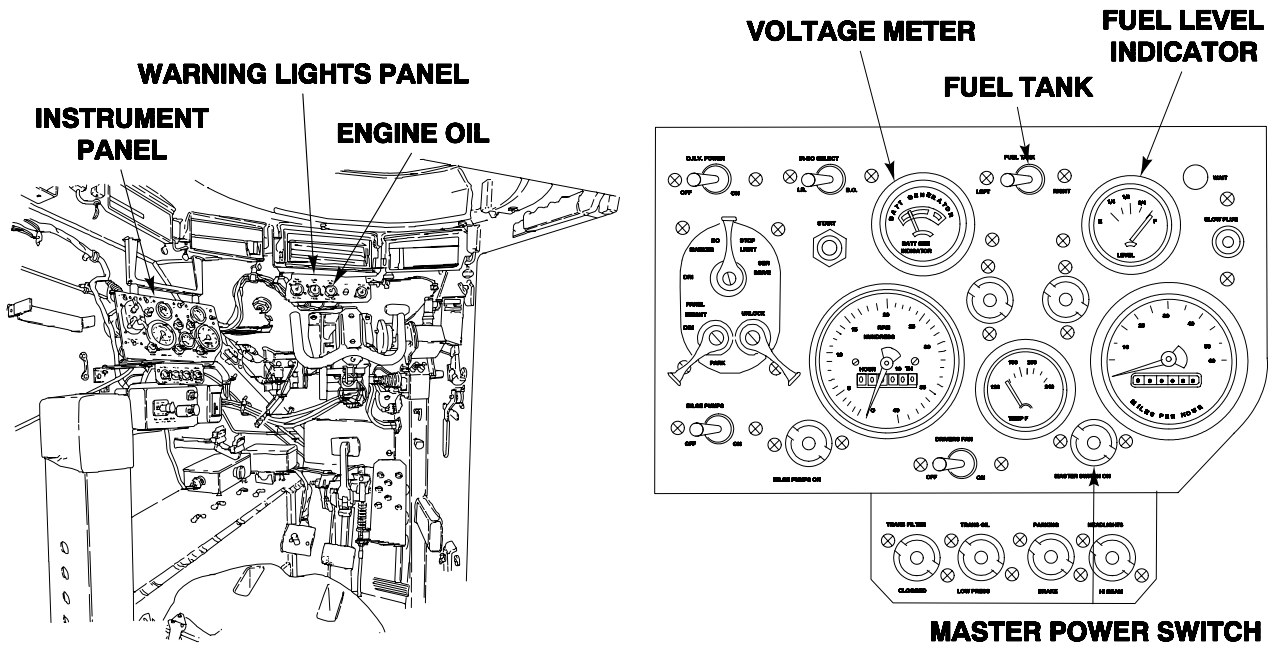
**NOTE**

Do Steps 6 - 29 for all vehicles.

6. Press and hold START switch.
7. Press and hold AIR BOX HEATER switch.

8. Hold both START and AIR BOX HEATER switches for approximately 45 seconds.

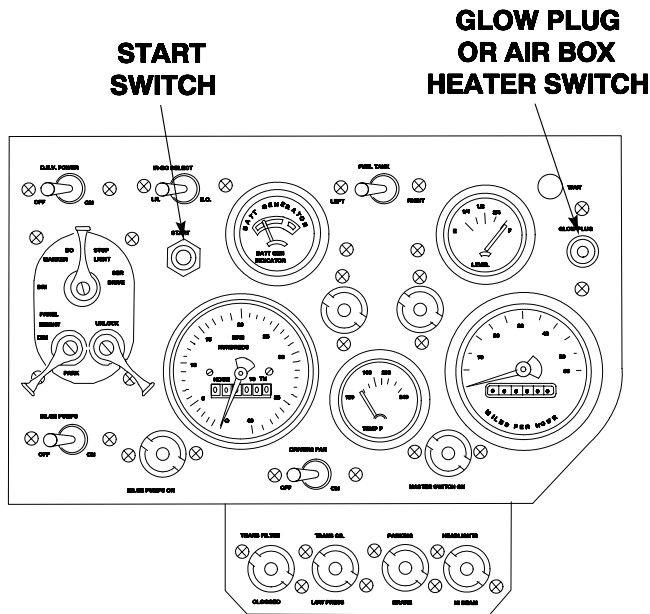

9. If engine does not start, press and hold both START and AIR BOX HEATER switches.
10. Hold AIR BOX HEATER switch for 10 seconds, then release for 3-4 seconds. The engine should start within two of these attempts. If engine starts, go to Step 20.

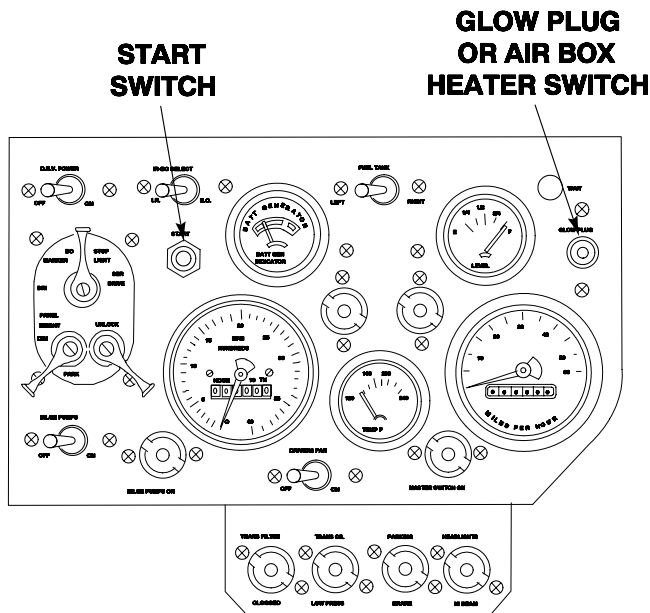

11. If engine does not start, release AIR BOX HEATER and START switches. Notify unit maintenance that AIR BOX HEATER and/or engine should be checked.

NOTE

Steps 12 - 19 are for vehicles equipped with glow plugs only.

12. Push hand throttle in.

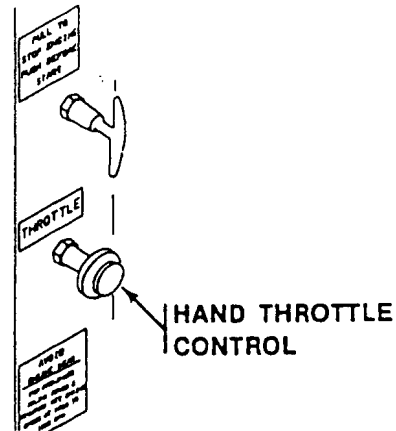
**NOTE**

GLOW PLUG switch is spring loaded to off position. Do not hold the GLOW PLUG switch in the on position.

13. Momentarily move GLOW PLUG switch up and release.
14. Wait for glow plug WAIT indicator to come on and begin flashing (approximately 35 seconds).

CAUTION

Do not engage START switch for more than five seconds at a time. Do not move engine throttle.

NOTE

If engine START switch is not pushed within one minute after glow plug WAIT indicator begins flashing, glow plug WAIT indicator will go off.

15. Push START switch and hold until engine starts, but no longer than five seconds at a time.

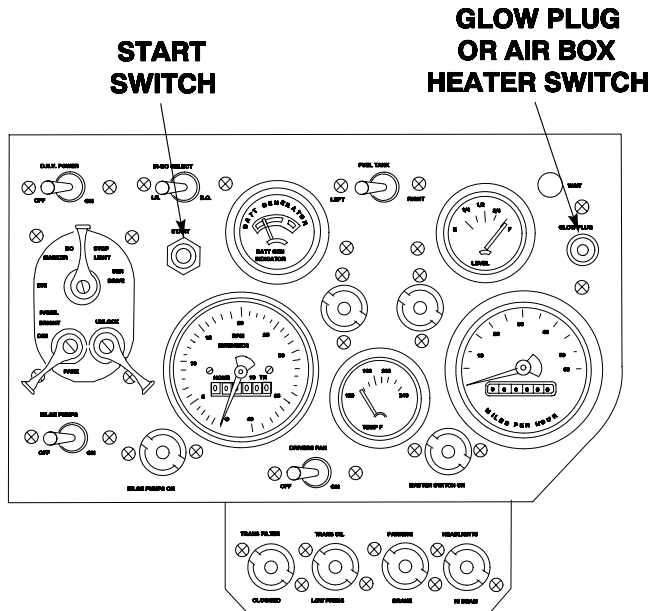

16. If engine does not start on first attempt, wait 10 seconds and try again.

CAUTION

If engine fails to start after four attempts, or when glow plug WAIT indicator goes out, stop start procedure.

17. Repeat Step 16 two more times if necessary. If engine still has not started, notify unit maintenance.

NOTE

After engine starts, WAIT indicator will stop flashing and stay on steady for one minute after START switch is released.

18. After engine starts, slowly increase engine speed until engine has reached a minimum speed of 1200 RPM. Do not exceed 1800 RPM.

CAUTION

If WAIT indicator does not go out after engine starts, or if WAIT indicator flashes during first 35 seconds, notify unit maintenance.

- Reduce engine speed to 1000-1200 RPM. Maintain this speed until engine reaches normal operating temperature (190°-230°F) (88° - 110°C).

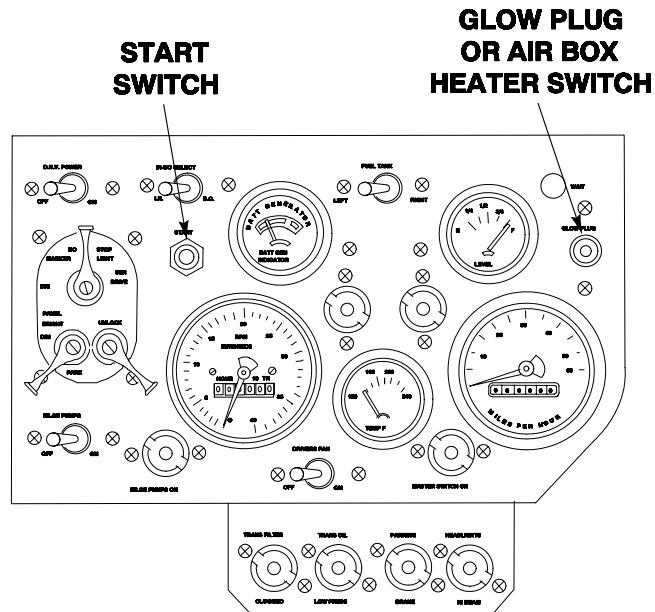

- Check that ENGINE OIL LOW PRESS warning light goes off within 10 seconds after engine starts.

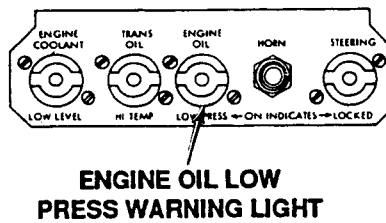

- Check that BATT GEN indicator points to green zone.

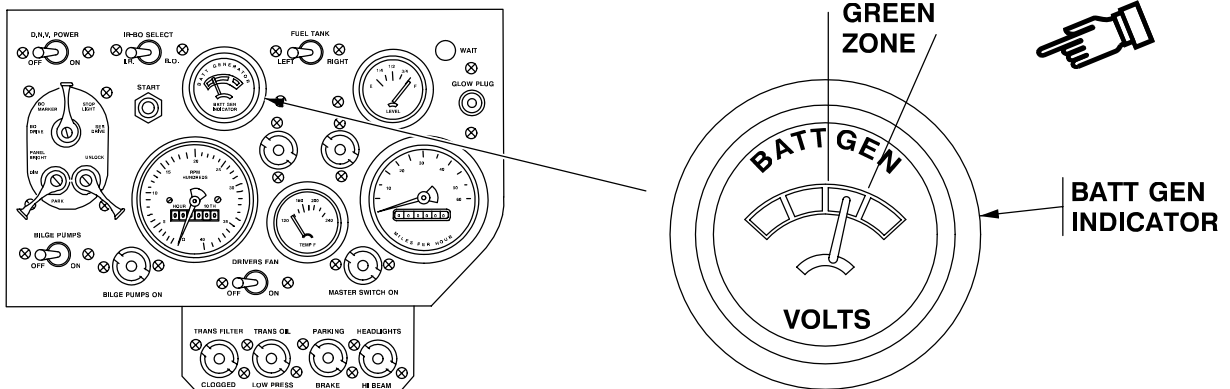

22. Run engine for 3 to 5 minutes at a normal idle.
23. Set hand throttle control to idle engine at 1200 to 1500 RPM for 5 minutes.
24. Stop engine by pulling out fuel cutoff control.

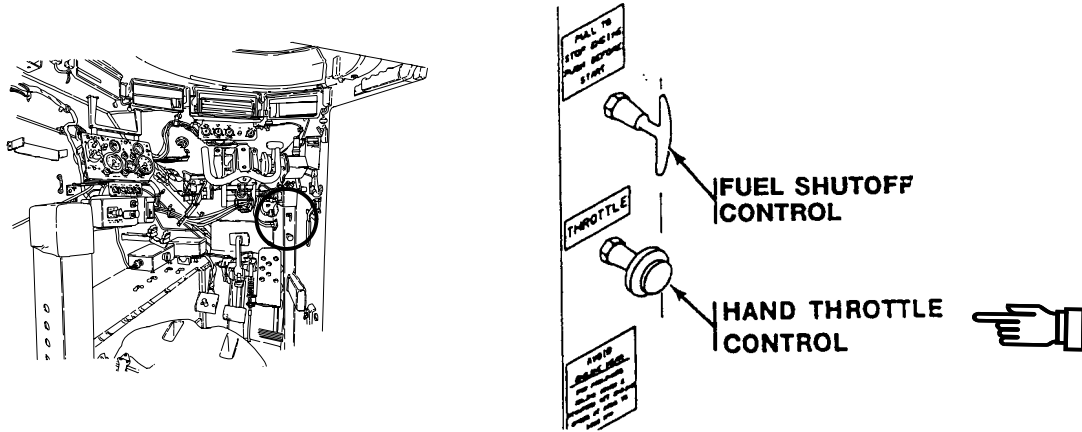

25. Perform a normal mild-temperature start.
26. Place transmission controller in the 2-3 range.

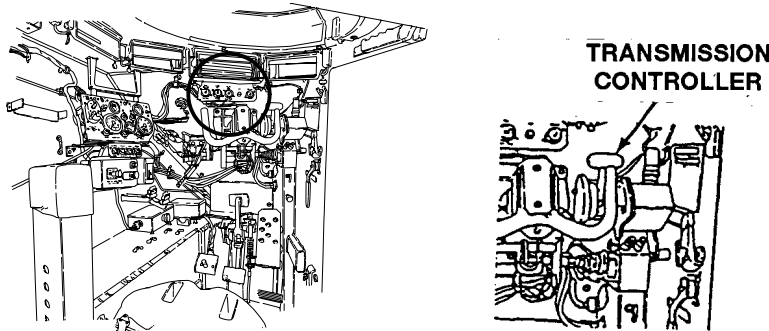

27. Set hand throttle control for 800 to 1000 RPM, and run engine for at least 10 minutes to warm up transmission.
28. Run engine at 1000 to 1200 RPM for about 5 minutes or until ENGINE COOLANT TEMPERATURE GAGE indicates 185° F (85°C).

29. Reduce engine to idle speed (650-700 RPM).

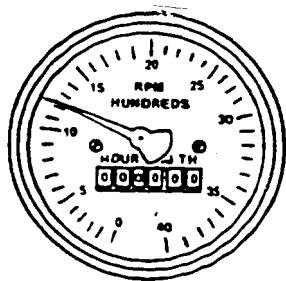
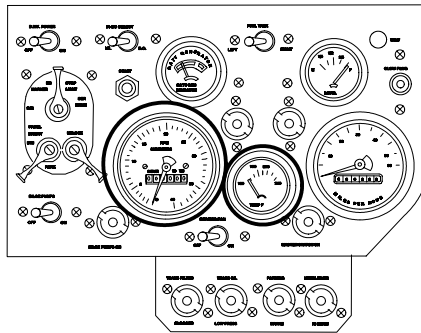

WARM UP RPM

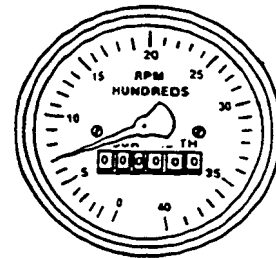
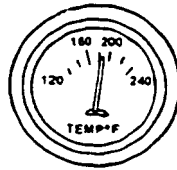

IDLE RPM

END OF TASK

START ENGINE WITH OUTSIDE POWER SOURCE

0022 00

THIS WORK PACKAGE COVERS:

Start Engine With Outside Power Source (page 0022 00-1).

INITIAL SETUP:

Maintenance Level

Operator

Equipment Condition

Carrier unable to start under own power
 Source carrier parked next to disabled carrier
 Source carrier engine stopped(WP 0024 00)

Tools and Special Tools

Slave Cable
 Source Carrier

Personnel Required

Driver (2)

START ENGINE WITH OUTSIDE POWER SOURCE

WARNING



If batteries are frozen, do not attempt to slave start vehicle. Explosion can occur causing injury to personnel and damage to equipment.

WARNING



Do not park live vehicle head to head with dead vehicle. Either vehicle could jump forward. Stay clear of area between vehicles during starting operations.

NOTE

For M577A3 and M1068A3, the 4.2 KW generator (old models) or 5 KW APU (new models) can be used.

1. Check that MASTER SWITCH is OFF on both carriers.
2. Remove cap from auxiliary power receptacle on both carriers.

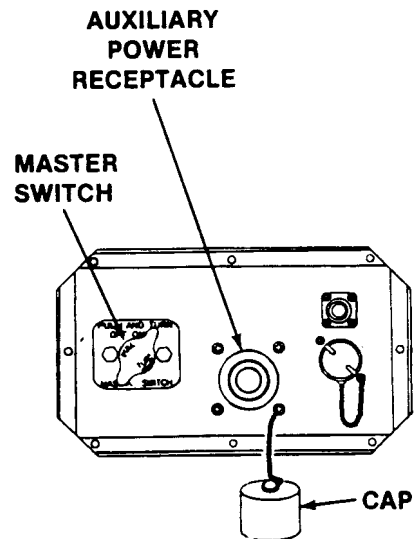
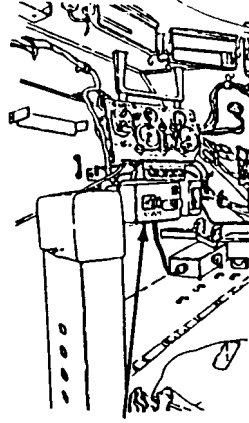

NOTE

Step 3 should be done if your M113A3 carrier is equipped with an M8 alarm system. If you do Step 3, connect leads and install distribution box cover after starting problem has been corrected.

3. Remove distribution box cover and disconnect M182 mount cable leads 509B and 509C before jump starting.

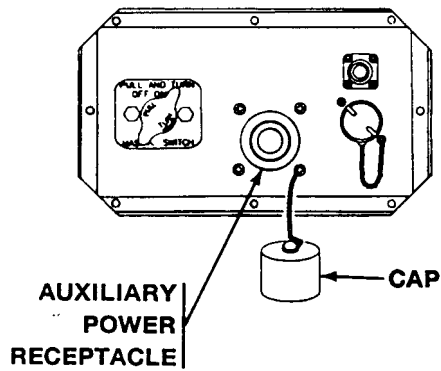
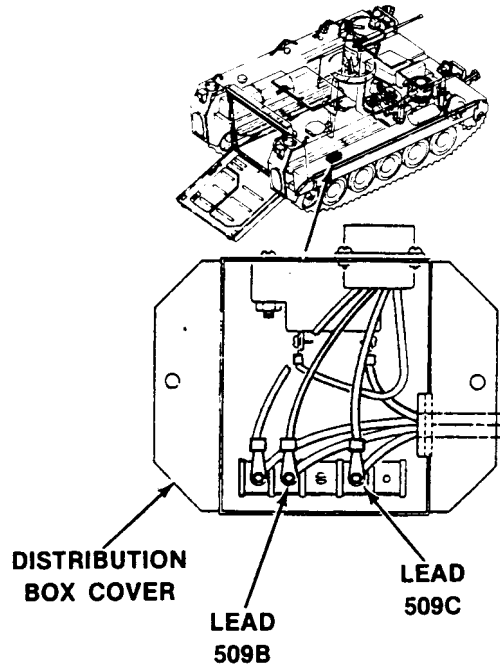

WARNING

Electrical slave cable can be improperly connected causing electrical spark or fire. Personnel can be killed or injured. Equipment can be damaged. Match connector guide lug and cable prongs with receptacle hole.

4. Connect slave cable to auxiliary power receptacle on disabled carrier.
5. Connect slave cable to auxiliary power receptacle on source carrier.
6. Start engine of source carrier. See task: START ENGINE, (WP 0021 00).
7. Run engine on source carrier at a fast idle (1000 rpm) for 5-10 minutes to show charging on BATT GEN indicator.

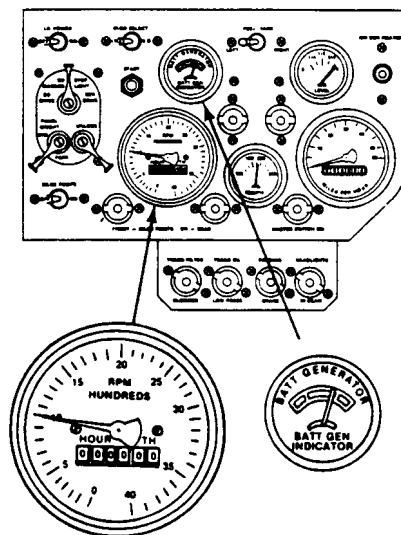
**NOTE**

In cold weather areas, air box heater can be switched on to heat engine on disabled carrier before attempting to start it.

8. Start engine on disabled carrier. See task: START ENGINE, (WP 0021 00).

WARNING



Electric sparking can burn you. Equipment can be damaged. Make sure to disconnect slave cable carefully not to cause any sparks.

9. Disconnect slave cable from auxiliary power receptacle on both carriers.
10. Install cap on auxiliary power receptacle on both carriers.

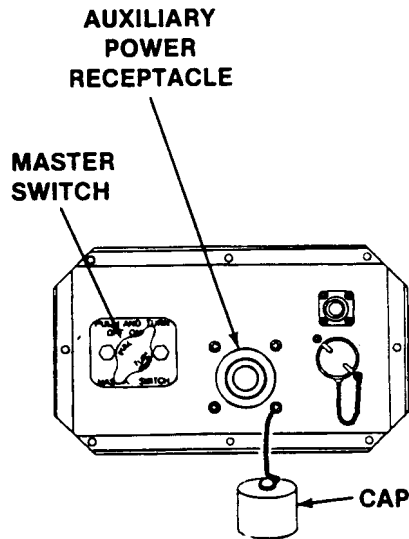
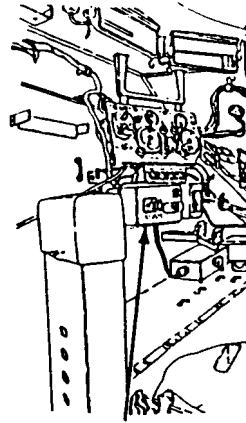

END OF TASK

DRIVE CARRIER

0023 00

THIS WORK PACKAGE COVERS:

Driving Precautions (page 0023 00-4).
 Drive Carrier (page 0023 00-6).

INITIAL SETUP:

Maintenance Level

Operator

Personnel Required

Driver

Equipment Condition

Engine started (WP 0021 00)
 Ramp raised and locked (WP 0012 00)
 Driver's hatch cover secured open or closed
 (WP 0006 00)
 Commander's hatch cover secured open or closed
 (WP 0009 00)
 Cargo hatch cover closed (WP 0008 00)

WARNING



Carrier noise can cause permanent hearing damage. Double hearing protection must be worn. See warning in front of manual.

WARNING

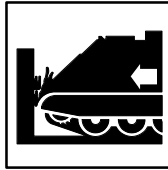

Vehicle operation during hot weather may result in heat stress to crew members. Crew members should limit their exposure to high temperature and humidity based on TB MED 507. Open door for ventilation, if appropriate.

WARNING

Sticking or damaged linkages can cause carrier crash. Personnel can be killed or injured. If accelerator pedal does not operate smoothly, or engine does not return to idle when accelerator pedal is released, do not drive carrier.

Loss of carrier control can cause carrier to crash. Personnel can be killed or injured. Avoid over steering at high speeds to prevent skidding or carrier upset. Use caution when turning on hills or side slopes.

WARNING

Unlatched hatch cover could swing and injure personnel. Make sure hatches are latched and secure.

WARNING

Do not attempt to change carrier forward or reverse movement by shifting until carrier comes to a complete stop. Above four miles per hour, if you attempt to shift into reverse (or forward), the carrier will continue in the direction you are moving when you attempted to make the change. Failure to follow the above instructions could result in injury or death to personnel and destruction of equipment or property.

WARNING

Brake pedal is very sensitive. Applying brake hard can cause carrier to stop suddenly. Personnel could be injured. Apply brake pressure lightly and with caution.

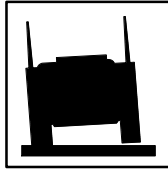
WARNING

When a track vehicle gets out of control and overturns, it is safer to stay in the vehicle than to try to get out while the vehicle is still moving. You may receive slight injuries from being thrown against metal parts; but if you try to leave the vehicle, it may roll over and crush you. Once the vehicle stops moving, get out as fast as possible because spilled fuel and oil may catch on fire. The first thing the driver should do in such an emergency is shut off the engine and turn off the master switch to minimize the fire hazard.

WARNING

Sudden carrier movement can throw you out of seat. Wear seat belt while carrier is in motion. Do not use any seat with missing or inoperative seat belt.

CAUTION

Avoid engine wear. For prolonged idling (over 5 minutes) set engine speed at 1000 to 1200 RPM. Do not operate vehicle with the TRANS OIL LOW PRESS warning light on. Operating the vehicle with the TRANS OIL LOW PRESS warning light on can damage the transmission and may result in unpredictable vehicle operation.

TRANS OIL LOW PRESS warning light may come on when brakes are released. Light should go out when engine speed reaches about 1200-1300 RPM. If it does not, stop engine and notify unit maintenance.

NOTE

The crossdrive transmission is designed not to change direction of movement at speeds above four miles per hour. If you attempt to shift into reverse while moving forward, above four miles per hour, the transmission will not go into reverse even with the shift lever set to “R” (reverse), and the carrier will continue to move forward when you accelerate. Likewise, if you attempt to shift into a forward gear while moving above four miles per hour in reverse, the carrier will continue to move in reverse when you accelerate.

DRIVING PRECAUTIONS

1. Use the 1-2 range until you get used to driving the carrier.

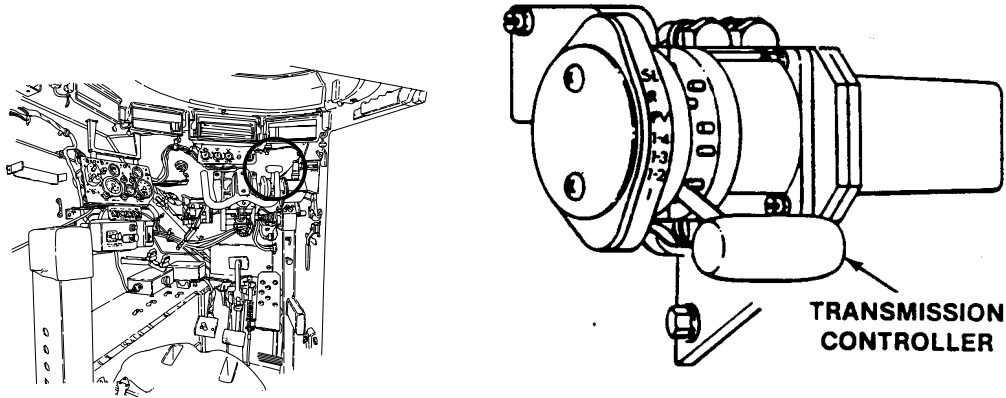

2. Take care not to oversteer or go too fast, especially on hard pavement. You could lose control of the carrier.
3. Decelerate as the carrier approaches the edge of a ditch or trench. Use gear range 1 or 1-2. Just as carrier bottoms out in a ditch or trench, accelerate and use full power as the carrier starts to climb. Maximum width of trench safely crossed is 5 1/2 feet (1.6 m).

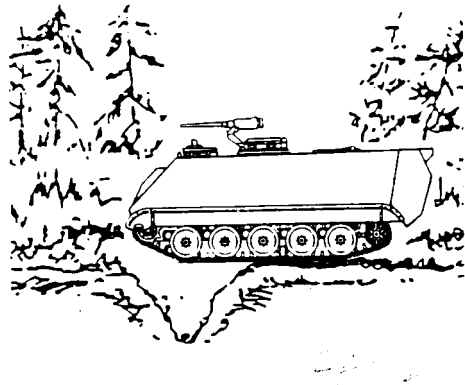

4. Accelerate as the carrier climbs a grade. Decelerate at the top of the grade and during descent. Use 1 range for 30% to 60% grades and 1-2 range for up to 30% grades.

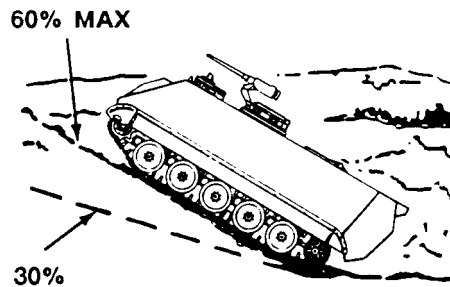

- Steer in a series of short turns on side slopes rather than one long even turn. This allows debris to feed out of the tracks. Use gear range 1 or 1-2.

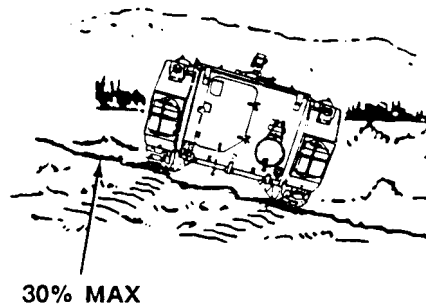

- Descend grades slowly. Shift to a lower range before starting down. Approach bottom cautiously to avoid digging. Use 1 range for 30% to 60% grades and 1-2 range for up to 30% grades. Don't use engine and transmission to hold carrier on a slope.

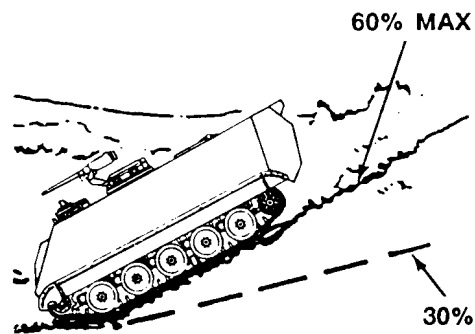

7. If any warning light comes on, STOP ENGINE (WP 0024 00) and troubleshoot problem (WP 0087 00).

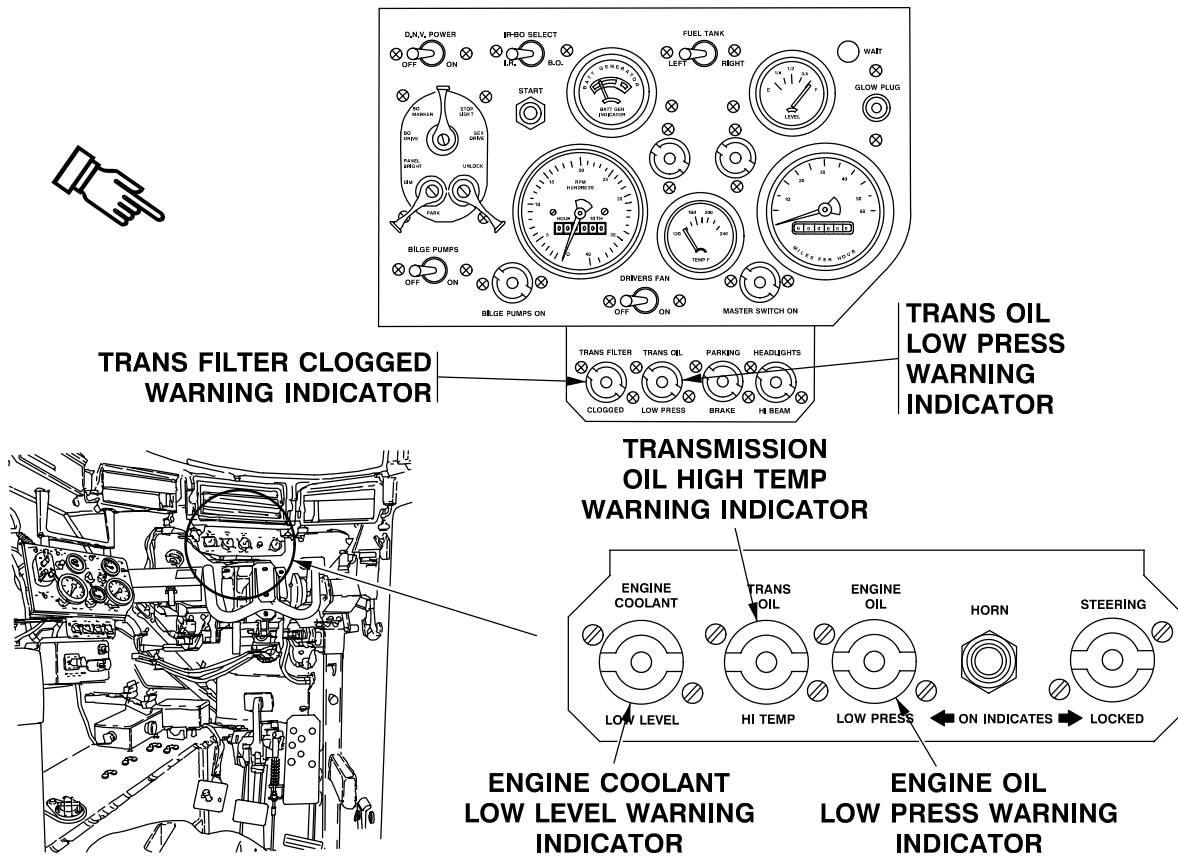

8. Check engine coolant temperature gauge. If temperature rises above 230°F (110°C) STOP ENGINE (WP 0087 00) and troubleshoot problem (WP 0087 00).

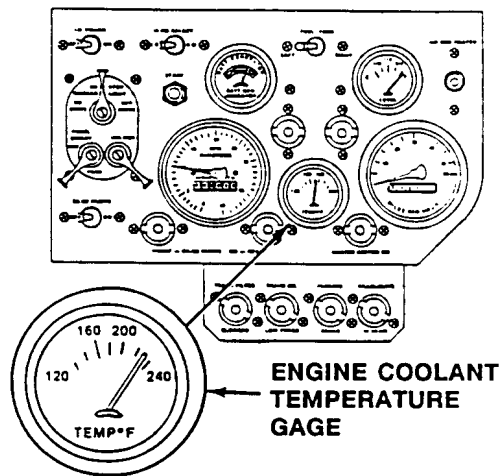

DRIVE CARRIER

1. Release parking brake (WP 0020 00).

NOTE

If tactical situation permits, sound horn to warn personnel carrier is about to move.

2. Press HORN switch.

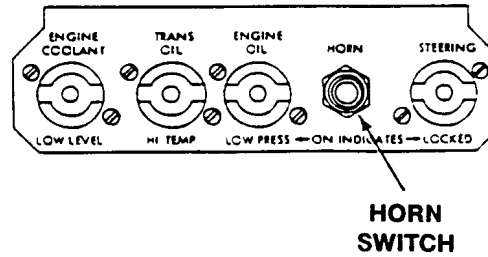

3. Depress and hold brake pedal.

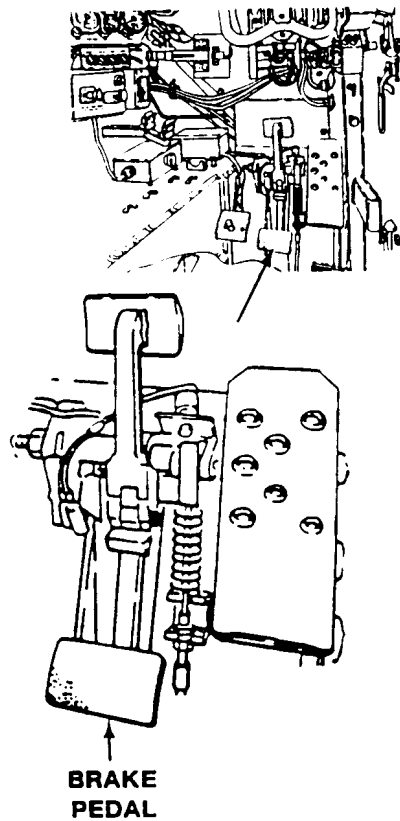

4. Select driving range desired (WP 0004 00).

5. With steering wheel centered, release brake pedal and slowly press accelerator pedal until carrier moves straight ahead.

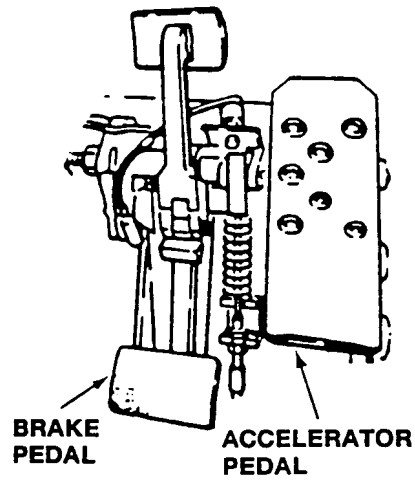
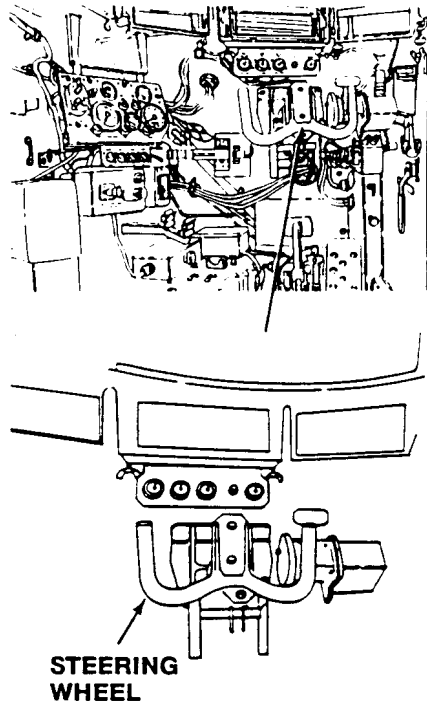

6. Turn steering wheel to the left to turn carrier left when driving forward.

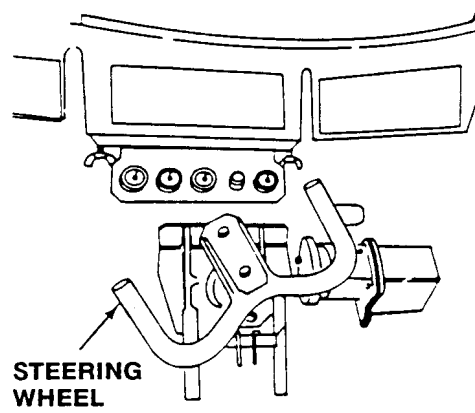

7. Turn steering wheel to the right to turn carrier right when driving forward.

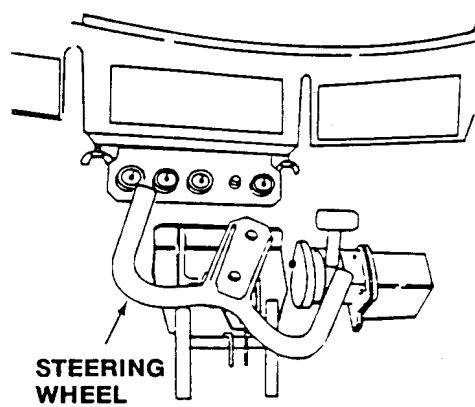

WARNING



Operating carrier in reverse is dangerous due to limited vision and reversed steering. Always post ground guides before you back up.

8. Place transmission controller in R position.

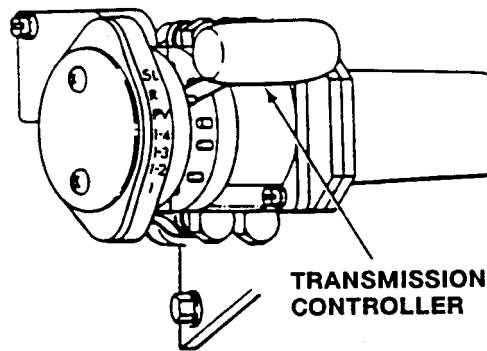

9. Turn steering wheel to the left to turn rear of carrier right when backing up.

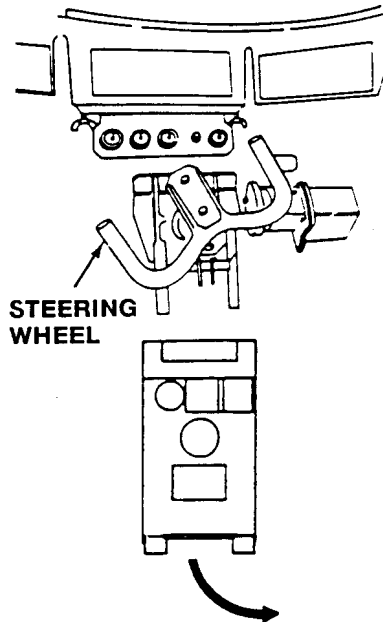

10. Turn steering wheel to the right to turn rear of carrier left when backing up.

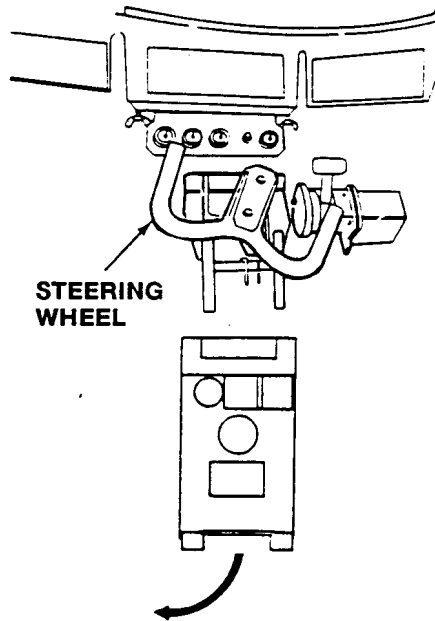

CAUTION

Avoid pivot steering on soft soil or gravel. Track may come off. After pivoting, drive ahead at least one carrier length to clear track.

Power unit can be damaged. Do not pivot steer when carrier is moving.

NOTE

Use pivot steer only when normal turns cannot be made in close areas. Stop carrier before making pivot steer.

11. Place transmission controller in PV position.

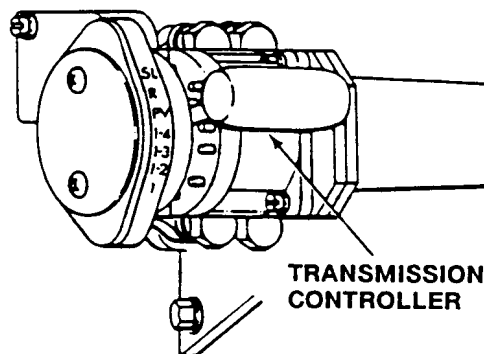

12. Turn steering wheel to the left and press accelerator pedal to pivot carrier left.

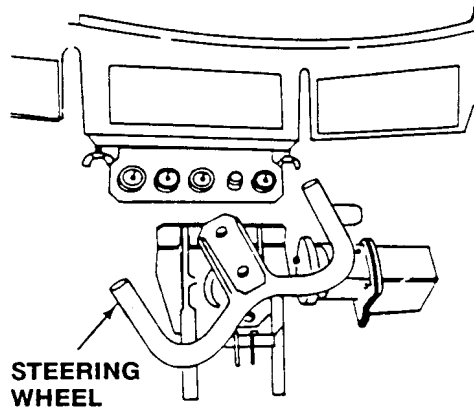

13. Turn steering wheel to the right and press accelerator pedal to pivot carrier right.

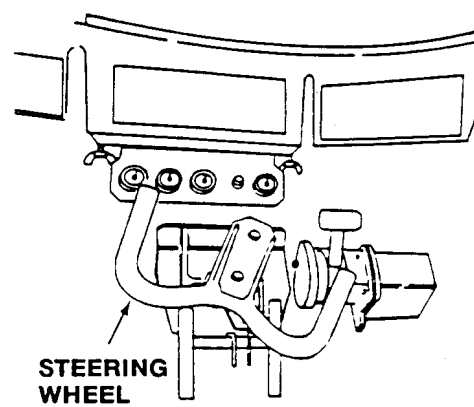

14. To stop carrier, press down on brake pedal with smooth, gradual pressure.

END OF TASK

STOP ENGINE

0024 00

THIS WORK PACKAGE COVERS:

Stop Engine (page 0024 00-1).

INITIAL SETUP:

Maintenance Level

Operator

Equipment Condition

Engine started (WP 0021 00)

Personnel Required

Driver

STOP ENGINE

1. Bring carrier to a complete stop.

WARNING



Carrier can pivot steer when transmission controller is in SL position and steering lock pin is not engaged. Personnel can be killed or injured. Make sure transmission controller is in SL and steering wheel is centered to engage steering lock pin (steering locked indicator light should be ON) unless carrier is to be steered.

2. Turn steering wheel to center position and place transmission controller in SL position to lock steering wheel.

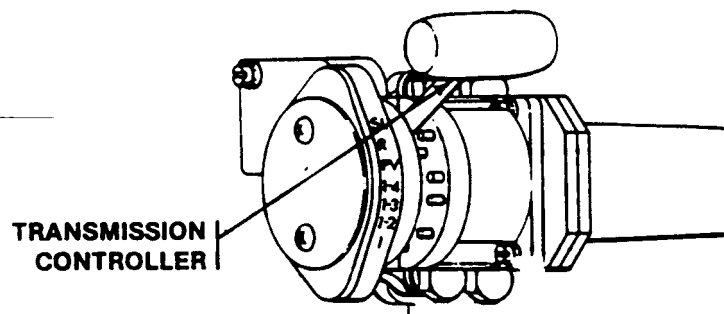
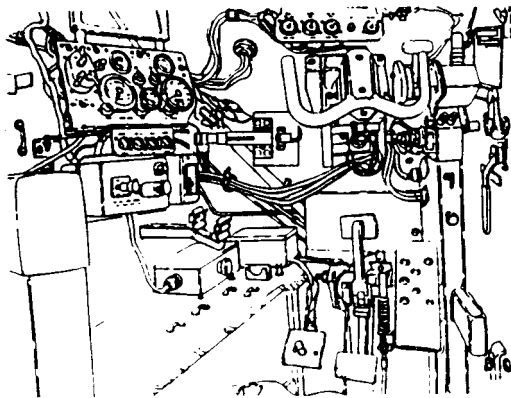
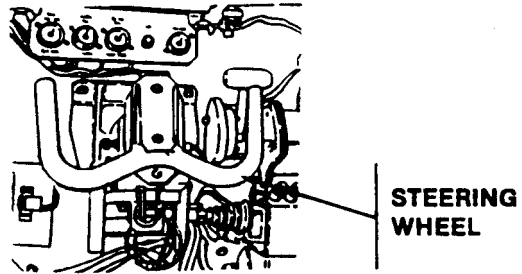

3. Set parking brake. See task: SET/RELEASE PARKING BRAKE (WP 0020 00).

CAUTION

In cold weather, stopping engine without a cooling down period can damage engine. Do not stop engine before coolant temperature reaches 185° F (85° C) or lower.

4. Run engine at 1000-1200 rpm for 3 to 5 minutes.

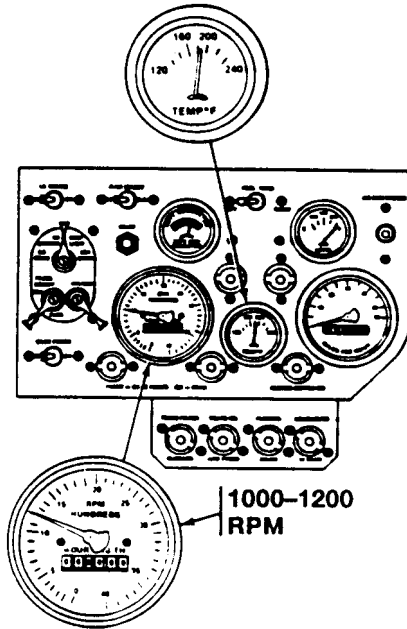

5. Return engine to idle speed (650-700 rpm).

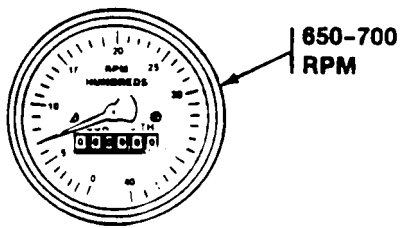

6. Pull fuel cutoff control all the way out to stop engine.

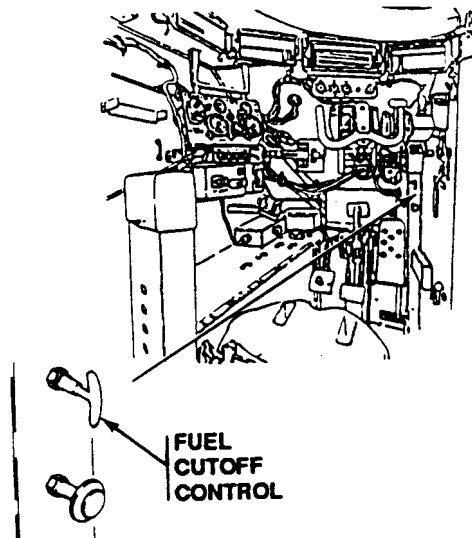

7. Turn MASTER SWITCH OFF.

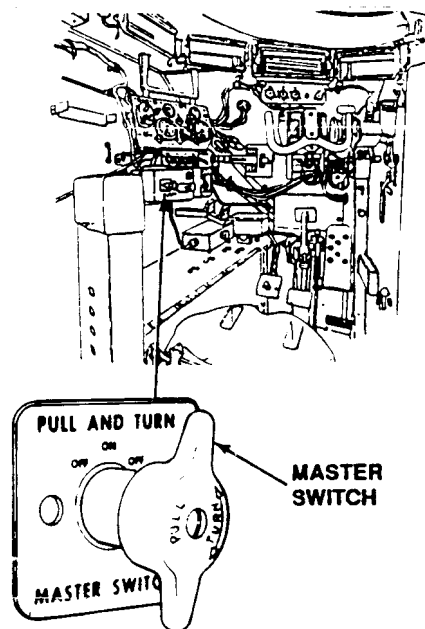

NOTE

If temperature is below -25°F (-31.7°C), start engine coolant heater. See task: OPERATE ENGINE COOLANT HEATER (WP 0062 00).

Steps 8 and 9 deleted.

END OF TASK

Change 2

0024 00-4

FUEL CARRIER

0025 00

THIS WORK PACKAGE COVERS:

Fuel Carrier (page 0025 00-1).

INITIAL SETUP:

Maintenance Level

Operator

References

WP 0026 00

Materials/Parts

Wiping Rag (WP 0104 00, Item 15)

Equipment Condition

Engine stopped (WP 0024 00)

Personnel Required

Driver

FUEL CARRIER

WARNING



Diesel fuel can catch fire and burn you. Do not smoke or allow open flame near carrier when fueling.

NOTE

Procedure for fueling left and right fuel tanks is the same.

The location for fueling the M577A3 and M1068A3 carriers is on the right side. See procedure for refueling M577A3 and M1068A3 (WP 0026 00).

1. Scrape paint from screw on carrier to be fueled and install fueling carrier ground wire to screw.

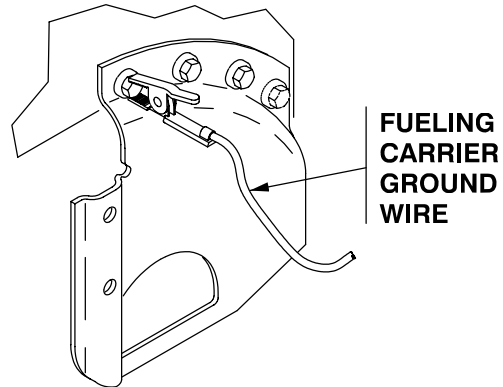
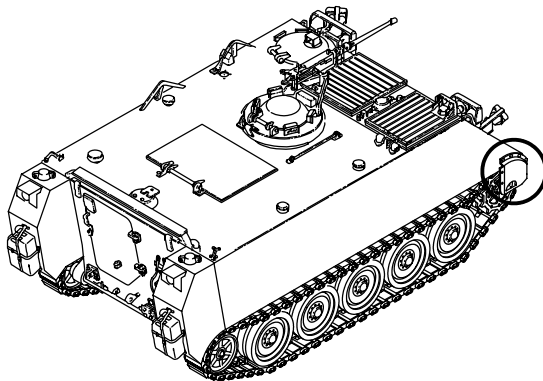

**FUELING
CARRIER
GROUND
WIRE**



2. Release combat cover lock by loosening wing nut and turning thumbscrew to the left.

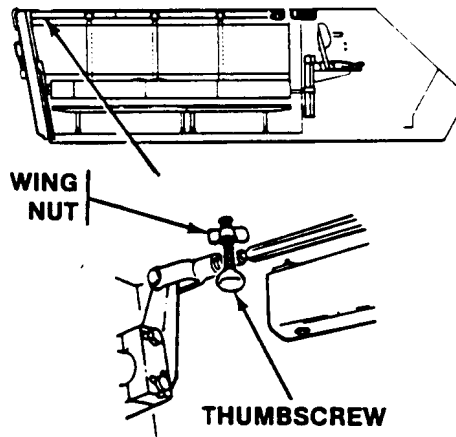
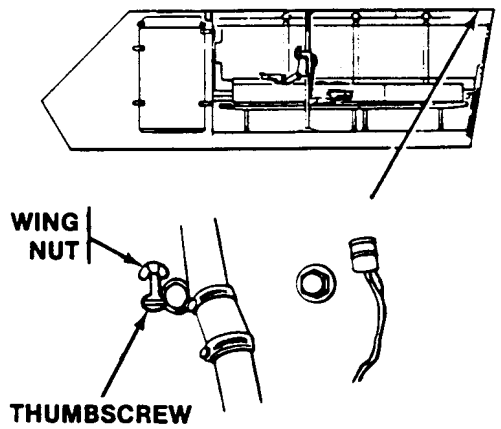

ALL EXCEPT M577A3 AND M1068A3

3. Pull locking pin and open combat cover.

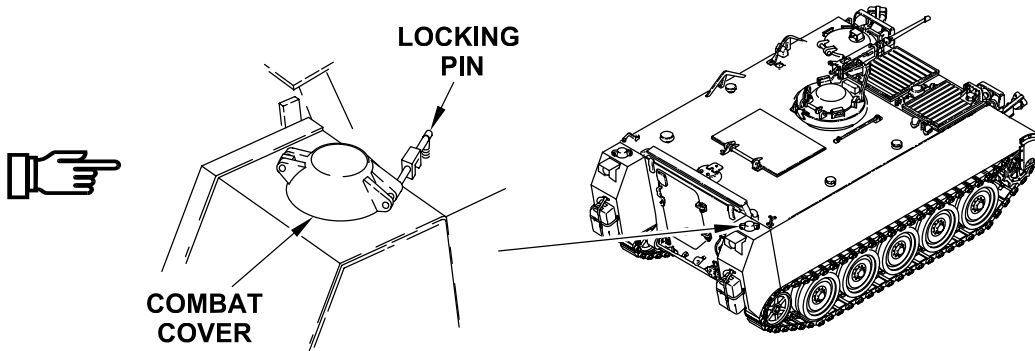

CAUTION

Contamination can damage fuel system. Remove dirt and water from fuel filler area before opening fuel filler cap.

- Remove any dirt and water from around fuel filler cap. Use wiping rag.

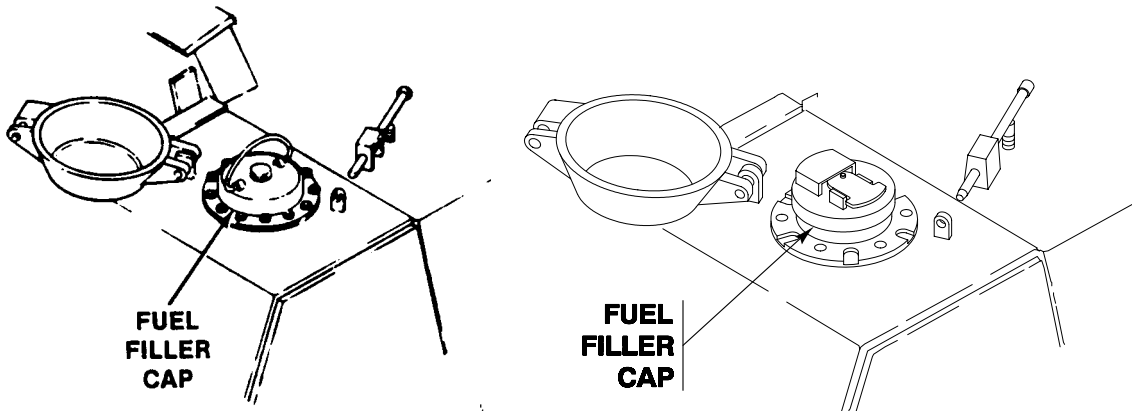
**NOTE**

Carrier may have optional cap with pressure relief valve.

- Remove fuel filler cap. If fuel cap has pressure relief valve, cap is removed by lifting pressure relief handle on fuel cap and turning cap counterclockwise.
- Remove fuel filler neck screen from fuel filler neck.
- Check fuel filler neck screen for damage and remove any dirt and debris. If fuel filler neck screen is damaged, notify unit maintenance.
- Install fuel filler neck screen in fuel filler neck.

WARNING

Sparks from static electricity could cause a fire or explosion. Metal nozzle must touch metal in fuel filler neck when fueling carrier or ground wire must be installed to carrier being fueled.

- Insert fuel nozzle in fuel filler neck. Fill fuel tank allowing 5 inches (13 cm) in fuel filler neck for expansion.
- Remove fuel nozzle from fuel filler neck.

NOTE

Carrier may have optional cap with pressure relief valve.

11. Install fuel filler cap. If fuel cap has pressure relief valve, cap is installed by turning clockwise until tight, then pushing pressure relief handle down.

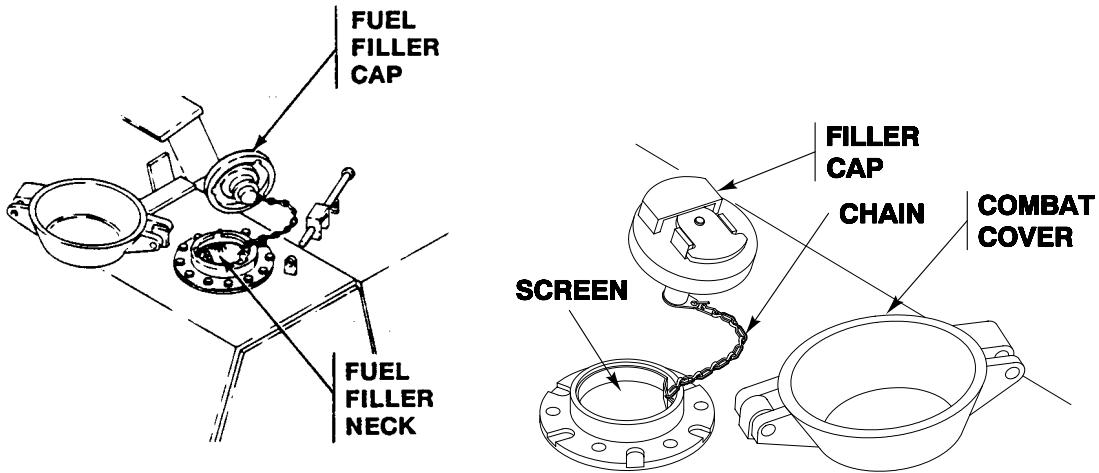

12. Pull locking pin and close combat cover. Release locking pin.

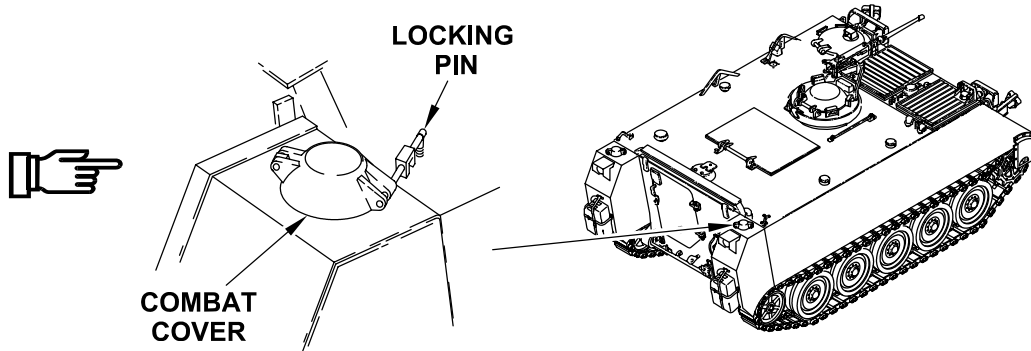

13. Secure combat cover lock by turning thumbscrew to the right. Tighten wing nut.

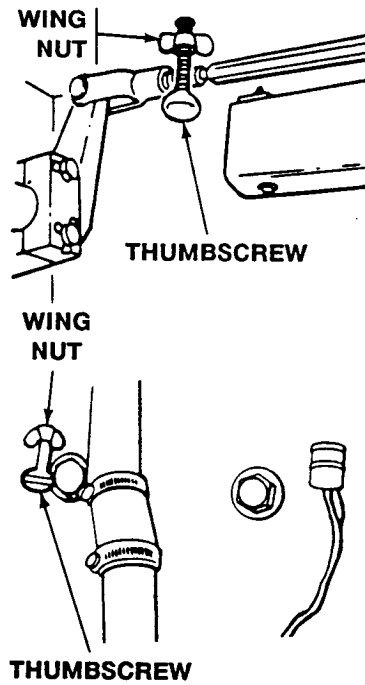

14. Remove fueling carrier ground wire from carrier.

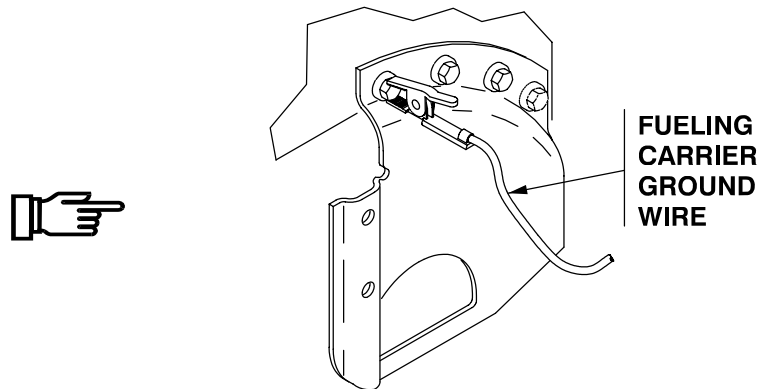

END OF TASK

REFUEL CARRIER (M577A3 AND M1068A3 ONLY)

0026 00

THIS WORK PACKAGE COVERS:

This task covers:
 Refuel (page 0026 00-2).

INITIAL SETUP:

Maintenance Level

Operator

Personnel Required

Driver

Equipment Condition

Engine stopped (WP 0024 00)

Carrier blocked (WP 0042 00)

Floor plates removed

NOTE

The engine fuel shutoff valve, personnel heater shutoff valve, auxiliary generator shutoff valve, and fuel drain shutoff valve are all located beneath the floor plates on the M577A3 and M1068A3.

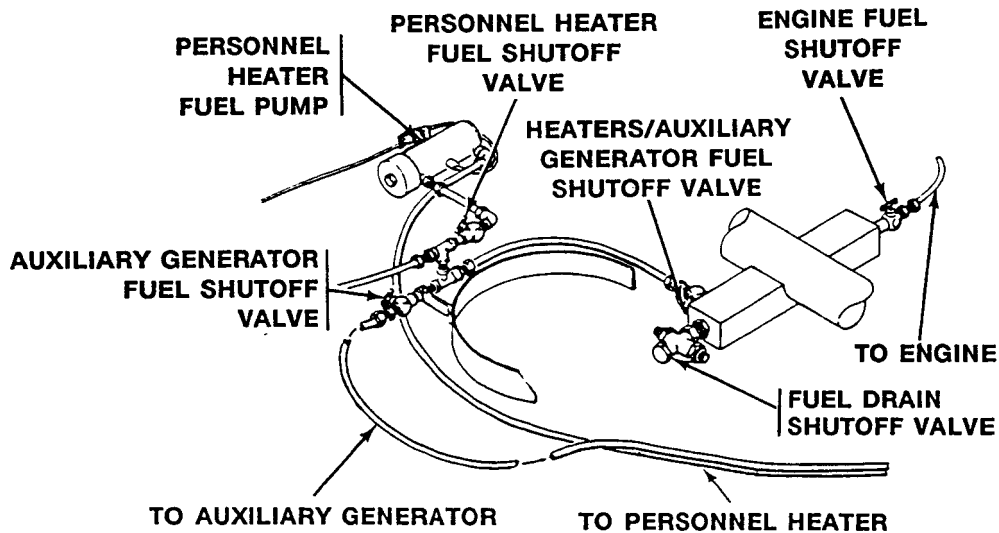

REFUEL CARRIER

WARNING

Diesel fuel can catch fire and burn you. Do not smoke or allow open flame near carrier when you are refueling.

1. Install fueling carrier ground wire to bare metal on carrier to be fueled.

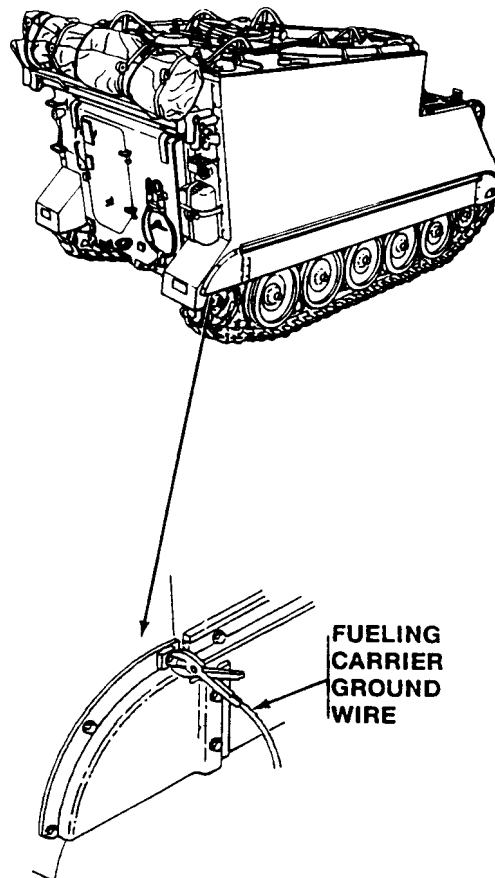

2. From inside carrier, unlock fuel filler combat cover by loosening wingnut and turning thumbscrew to the left.

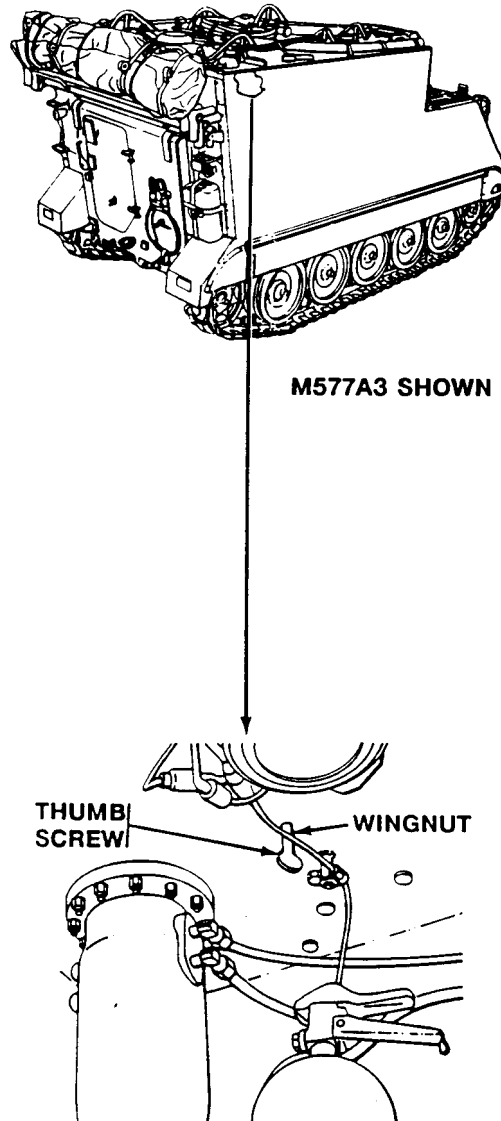

- From outside carrier, open combat cover.

CAUTION

Contamination can damage fuel system. Remove dirt and water from fuel filler area before opening fuel filler cap.

- Clean off any dirt and water that could get into filler neck. Use wiping rag.

NOTE

Carrier may have optional cap with pressure relief valve.

- Unscrew filler cap. If fuel cap has pressure relief valve, cap is removed by lifting pressure relief valve handle on fuel cap and turning cap counterclockwise.
- Check screen in filler neck. If there is any dirt in screen, take screen out and clean it. Install screen before refueling.

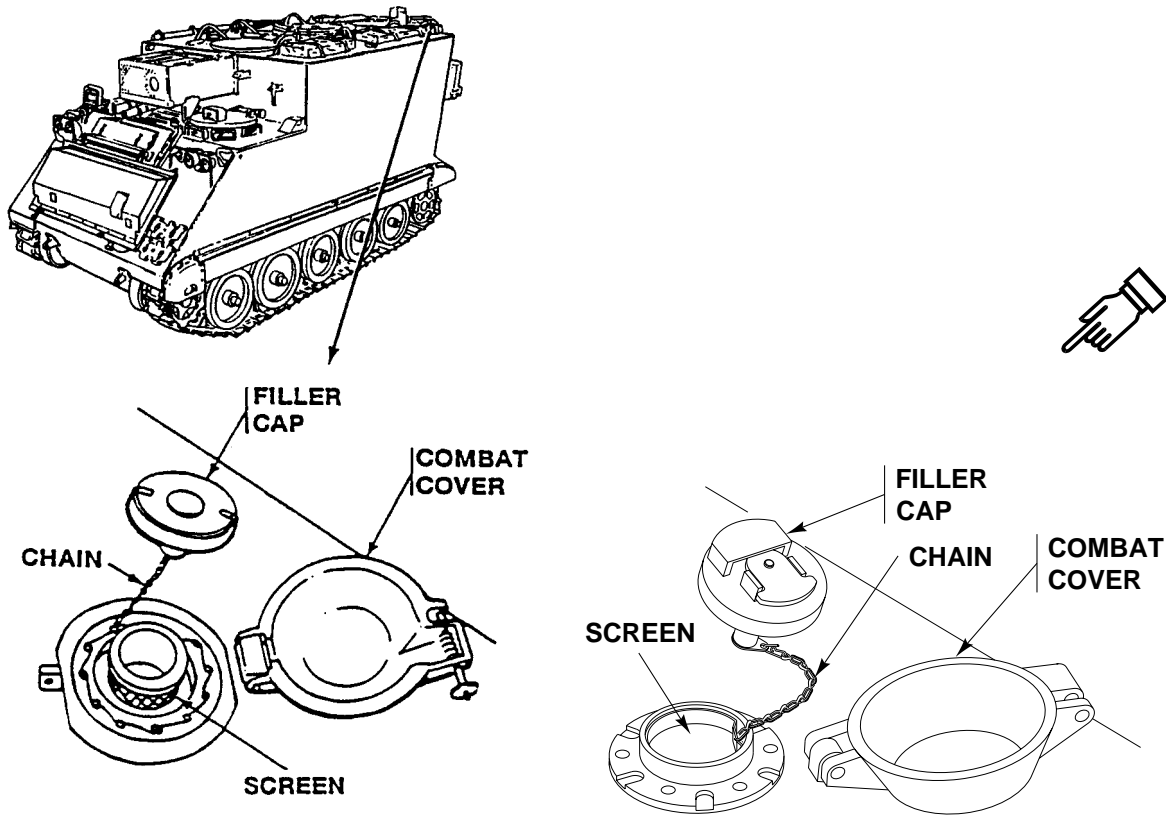

WARNING

Sparks from static electricity could cause a fire or explosion. Metal nozzle must touch metal in fuel filler neck when fuel is running.

7. Insert nozzle in fuel filler neck. Fill fuel tank allowing 5 inches in fuel filler neck for expansion.
8. Remove fuel nozzle from fuel filler neck.

NOTE

Carrier may have optional cap with pressure relief valve.

9. Install fuel filler cap. Make sure keeper chain is all inside so cap goes on tight. If fuel cap has pressure relief valve, cap is installed by turning clockwise until tight then pushing pressure relief valve handle down.
10. Close combat cover.
11. Lock combat cover from inside carrier by turning thumbscrew to the right. Tighten wingnut.
12. Remove fueling carrier ground wire from carrier.

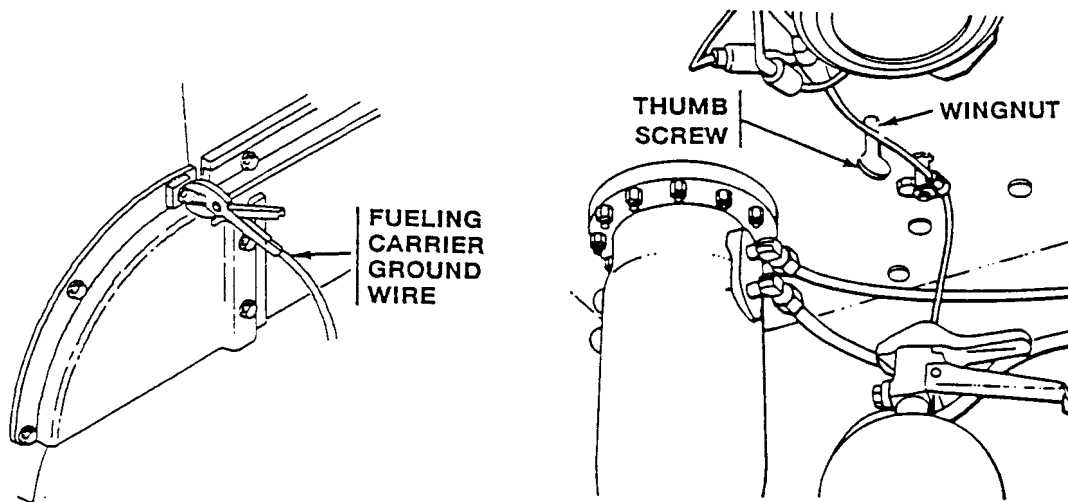

END OF TASK

INSTALL/REMOVE WINDSHIELD

0027 00

THIS WORK PACKAGE COVERS:

Install Windshield (page 0027 00-1).
 Remove Windshield (page 0027 00-3).

INITIAL SETUP:

Maintenance Level

Operator

Equipment Condition

Engine stopped (WP 0024 00)

Personnel Required

Driver

INSTALL WINDSHIELD

CAUTION

Windshield panels are easily scratched. Handle windshield with care.

NOTE

Location varies by model of carrier. See stowage guide WP 0107 00.

1. Loosen two straps and remove windshield storage bag from rear bulkhead.

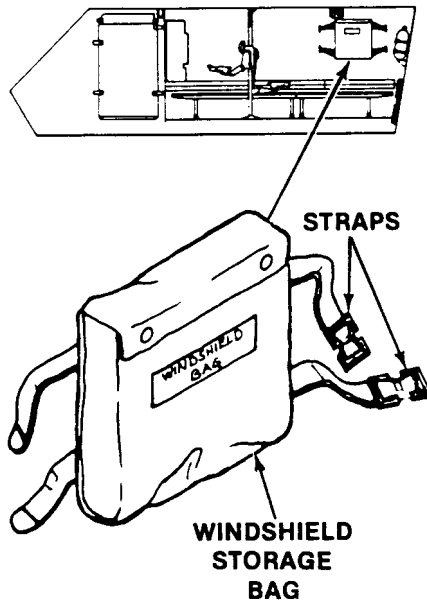

2. Remove windshield from storage bag.

3. Install windshield pins in mounting brackets. Tuck skirt of windshield between driver's hatch and periscope guards.

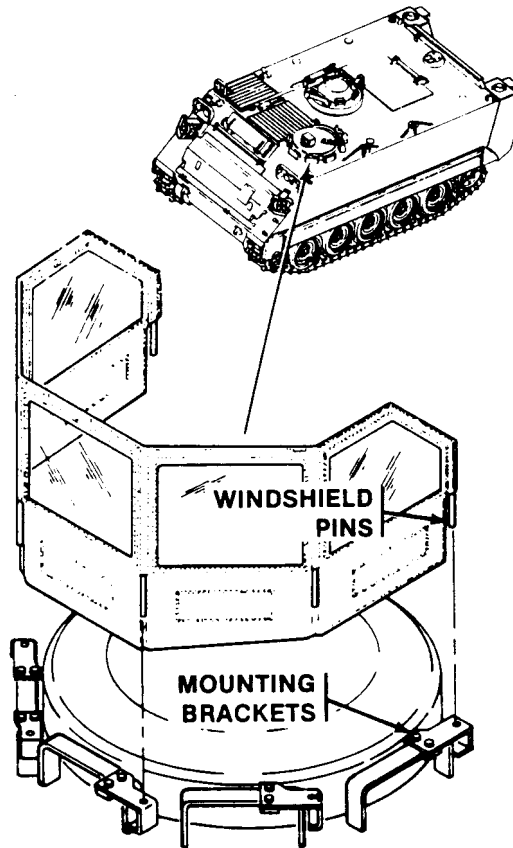

REMOVE WINDSHIELD**CAUTION**

Window panels will crack if folded after use in extreme cold weather. Warm windshield before folding.

1. Remove windshield pins from mounting brackets.
2. Fold windshield and stow in storage bag.
3. Return storage bag to rear bulkhead and secure with two straps.

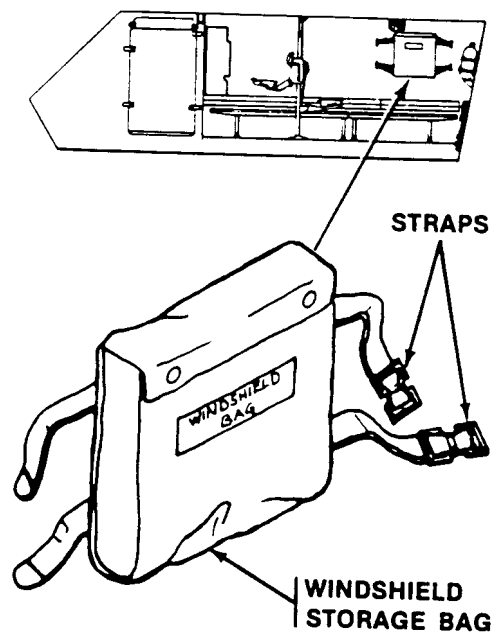

END OF TASK

OPERATE PERSONNEL HEATER

0028 00

THIS WORK PACKAGE COVERS:

- Turn Personnel Heater On (page 0028 00-1).
- Turn Personnel Heater Off (page 0028 00-4).

INITIAL SETUP:

Maintenance Level
Operator

Personnel Required
Driver

WARNING

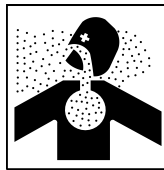

Exhaust from personnel heater can kill you. Do not breathe exhaust gases. If you detect or suspect fumes, turn heater off and open all hatches right away. See warning in the front of this manual.

WARNING



Ammunition can explode and kill you. Do not start heater until ammunition and combustible/explosive materials are properly stored at least 30 inches from heater vents. Combustible materials must be stored 12 inches or more from metal surfaces of heater.

TURN PERSONNEL HEATER ON

1. Check air intake elbow and heater exhaust elbow to make sure they are clear of debris.

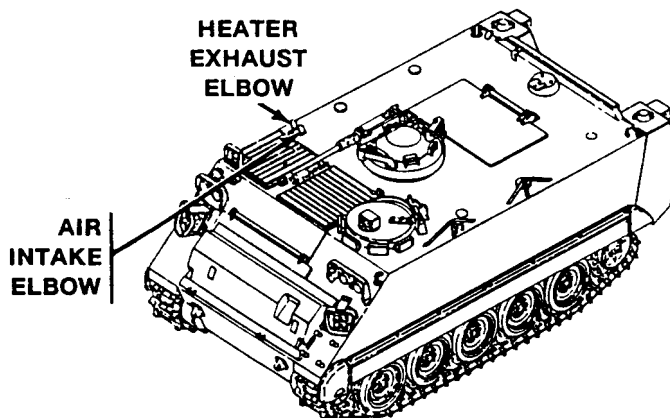

NOTE

Location of heater fuel supply valve varies between models.

2. Make sure heater fuel supply valve is open.

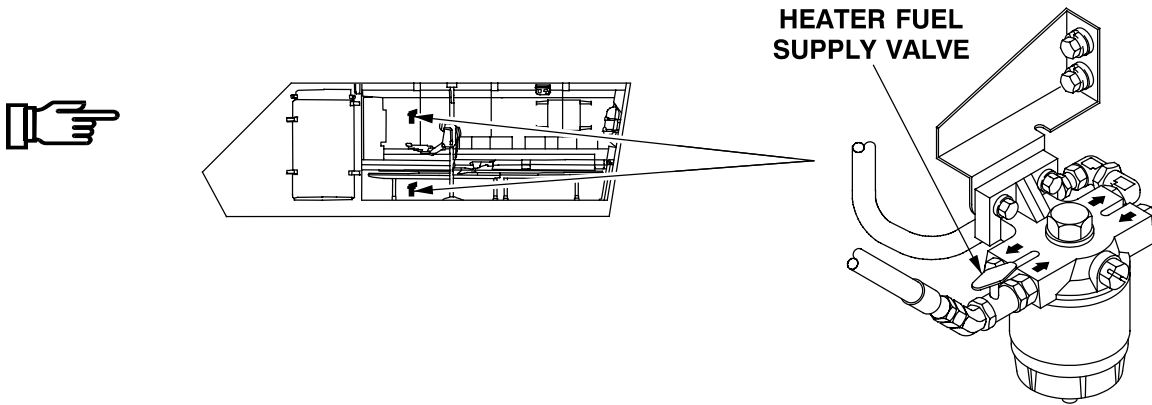

3. Press PRESS-TO-TEST switch. Check that HEATER light comes on.
4. Move HI-LO switch to LO.

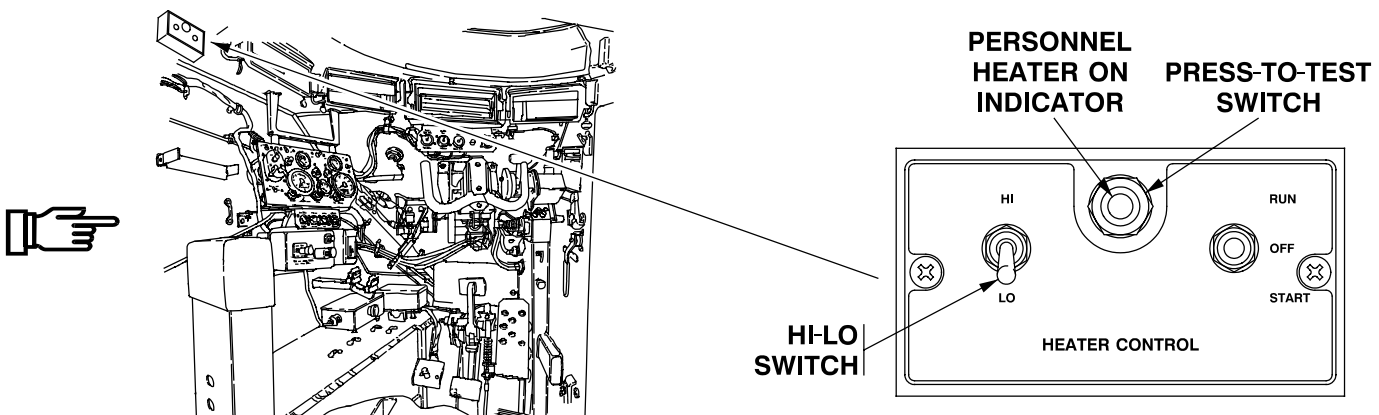

NOTE

Heater startup varies with the type of heater installed in your carrier.

For heater P/N 10560M24B1, see Step 5 and Step 6.

For heater P/N MF510B or P/N MF510C, see Step 7 and Step 8.

For heater P/N 5000-30178, see Step 9 and Step 10 and also TM 9-2540-207-14&P.

5. Move RUN-OFF-START switch to START for 2 minutes. If HEATER light does not come on, move RUN-OFF-START switch to OFF for 10 seconds. Move RUN-OFF-START switch to START for 1 minute. If HEATER light does not come on, move RUN-OFF-START switch to OFF for 10 seconds. Move RUN-OFF-START switch to START for 1 minute. If heater fails to start after third try, troubleshoot heater, see WP 0087 00.

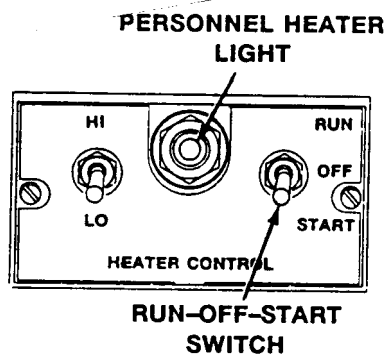

6. Move RUN-OFF-START switch to RUN as soon as HEATER light comes on. Do not stop in OFF position.

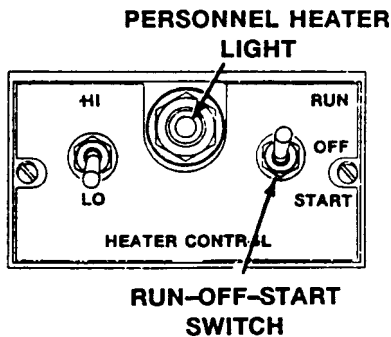

NOTE

Step 7 and Step 8 apply to heater P/N MF510B or P/N MF510C only.

7. Move RUN-OFF-START switch to START for 4 minutes. If HEATER light does not come on, move RUN-OFF-START switch to OFF. Wait at least 15 minutes. Move RUN-OFF-START switch to START for 4 minutes. If heater fails to start after second try, troubleshoot heater, see WP 0087 00.
8. Move RUN-OFF-START switch to RUN as soon as HEATER light comes on. Do not stop in OFF position.

NOTE

Personnel heater always starts at low heat. It changes to high heat if HI-LO switch is set at HI.

NOTE

If you operate heater for an extended time, start engine to keep batteries charged. See task: START ENGINE, WP 0021 00.

NOTE

Step 9 and Step 10 apply to heater Model A20, P/N 5000-30178 only.

9. Move the RUN/OFF/START switch momentarily to START for at least four (4) seconds, and then move the switch to RUN. The heater will now run automatically and does not require any further actions by the operator.
10. CONTROL BOX WARNING INDICATOR LIGHT. If the control box lamp begins to flash, the heater is signaling that an abnormal condition is present. Read diagnostic display codes at the heater and take appropriate action. Move HI-LO switch to HI or LO.

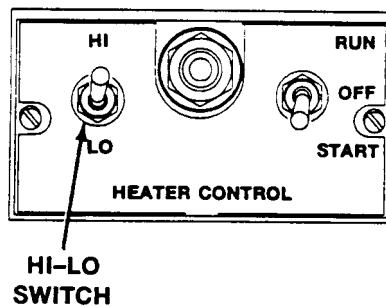

TURN PERSONNEL HEATER OFF

NOTE

When personnel heater is turned off, blower will run until personnel heater cools off. HEATER light will go off when personnel heater cools off. Driver should stay in carrier until blower stops.

1. Move RUN-OFF-START switch to OFF.

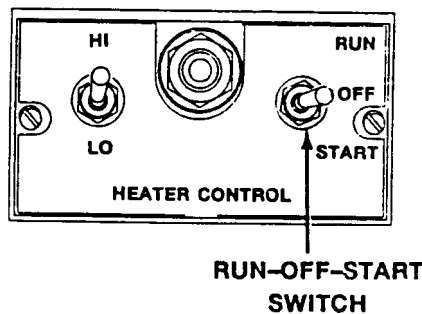

2. Let personnel heater purge itself.

END OF TASK

OPERATE PERSONNEL COMPARTMENT VENTILATOR

0029 00

THIS WORK PACKAGE COVERS:

Operate Personnel Compartment Ventilator (page 0029 00-1).

INITIAL SETUP:

Maintenance Level

Operator

Equipment Condition

All hatch covers closed

Personnel Required

Soldier

OPERATE PERSONNEL COMPARTMENT VENTILATOR

WARNING

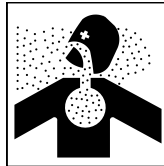

Lack of air in carrier can make personnel dizzy. When operating carrier with hatch covers closed, make sure personnel compartment ventilator is open.

NOTE

Location of ventilator may vary in each vehicle.

1. Push up on personnel compartment ventilator control until ventilator locks in open position.
2. Pull down on personnel compartment ventilator control to close ventilator.

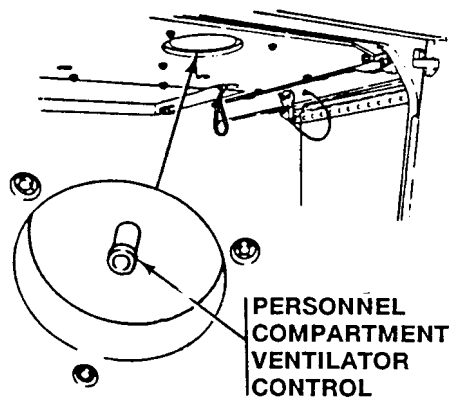

- 3. DELETED.

END OF TASK

OPERATE CARRIER LIGHTS

0030 00

THIS WORK PACKAGE COVERS:

- Operate Headlights (page 0030 00-1).
- Operate Blackout Marker (page 0030 00-2).
- Operate Blackout Marker and Blackout Driving Lights (page 0030 00-3).
- Operate Stop Light (page 0030 00-4).
- Operate Infrared Headlights (page 0030 00-5).
- Operate Panel and Transmission Controller Lights (page 0030 00-6).
- Operate White Dome Lights (page 0030 00-7).
- Operate Blackout Dome Lights (page 0030 00-7).

INITIAL SETUP:

Maintenance Level

Operator

Equipment Condition

MASTER SWITCH ON

Personnel Required

Driver

OPERATE HEADLIGHTS

1. Move LIGHTS UNLOCK switch to UNLOCK, and hold.
2. Move panel and transmission controller lights switch to OFF.
3. Move DRIVING LIGHTS switch to SER DRIVE.

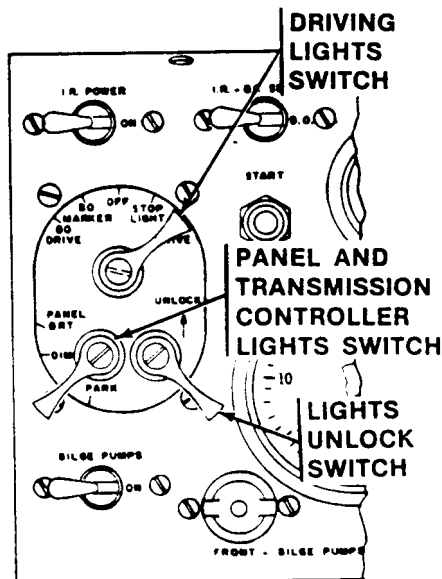

4. Press beam selector switch for high or low beam.

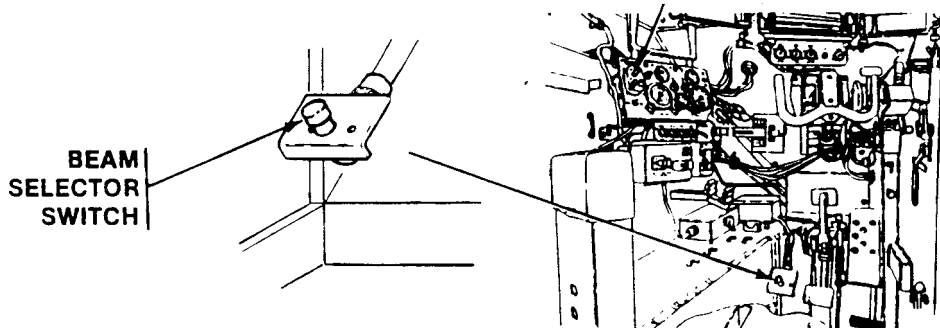

5. Release LIGHTS UNLOCK switch.
6. Move DRIVING LIGHTS switch to OFF.

OPERATE BLACKOUT MARKER

1. Move DRIVING LIGHTS switch to BO MARKER.
2. Move panel and transmission controller lights switch to OFF.
3. Move DRIVING LIGHTS switch to OFF.

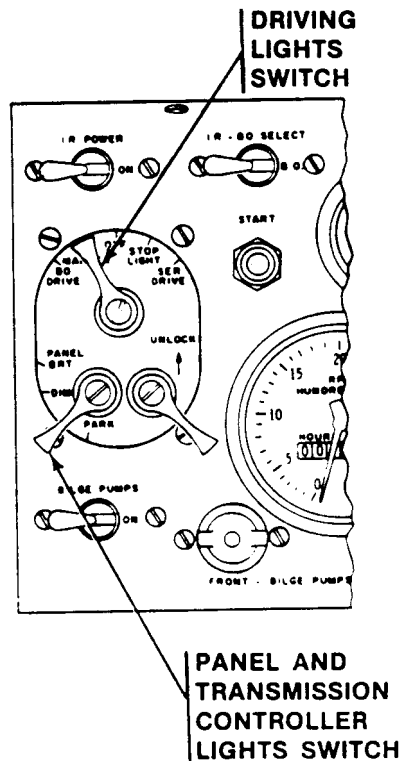

OPERATE BLACKOUT MARKER AND BLACKOUT DRIVING LIGHTS

1. Move LIGHTS UNLOCK switch to UNLOCK, and hold.
2. Move panel and transmission controller lights switch to OFF.
3. Move DRIVING LIGHTS switch to BO DRIVE.
4. Release LIGHTS UNLOCK switch.
5. Move IR-BO SELECT switch to BO.
6. Move DRIVING LIGHTS switch to OFF.

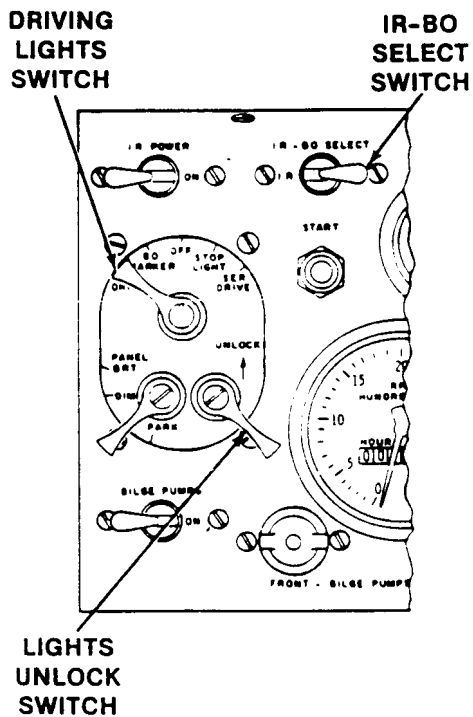

OPERATE STOP LIGHT

1. Move LIGHTS UNLOCK switch to UNLOCK, and hold.
2. Move panel and transmission controller lights switch to OFF.
3. Move DRIVING LIGHTS switch to STOP LIGHT.
4. Release LIGHTS UNLOCK switch.
5. Press brake pedal.
6. Release brake pedal.
7. Move DRIVING LIGHTS switch to OFF.

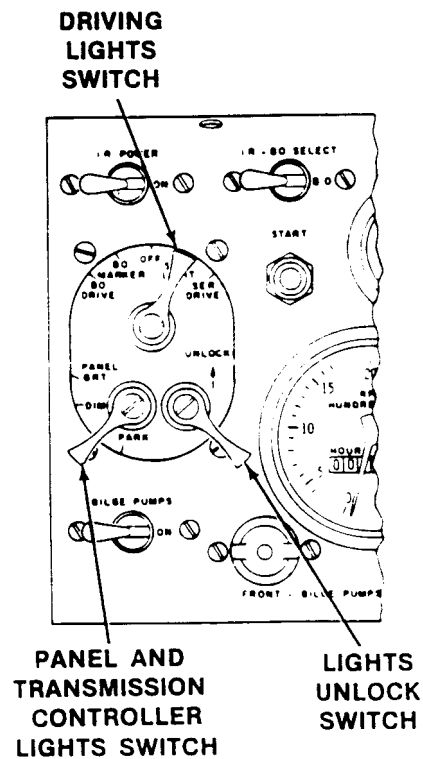

OPERATE INFRARED HEADLIGHTS

1. Move LIGHTS UNLOCK switch to UNLOCK, and hold.
2. Move panel and transmission controller lights switch to OFF.
3. Move DRIVING LIGHTS switch to BO DRIVE.
4. Release LIGHTS UNLOCK switch.
5. Move IR-BO SELECT switch to IR.
6. Press beam selector switch for high or low beam.
7. Move DRIVING LIGHTS switch to OFF.

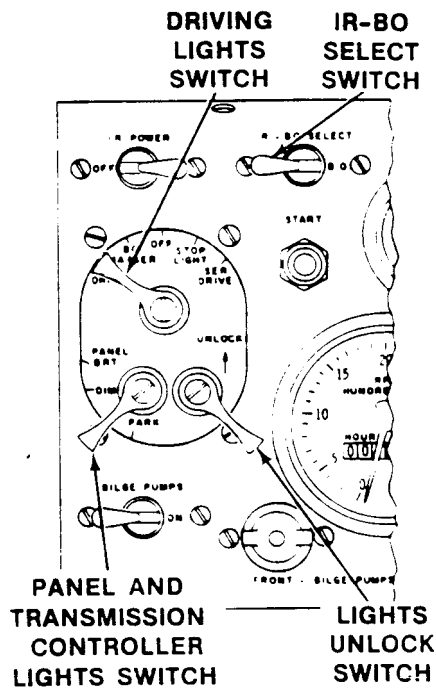

OPERATE PANEL AND TRANSMISSION CONTROLLER LIGHTS

NOTE

To operate panel and transmission controller lights, DRIVING LIGHTS switch can be in any position except OFF.

1. Move panel and transmission controller lights switch to DIM or to PANEL BRT.
2. Move panel and transmission controller lights switch to OFF.
3. Move DRIVING LIGHTS switch to OFF.

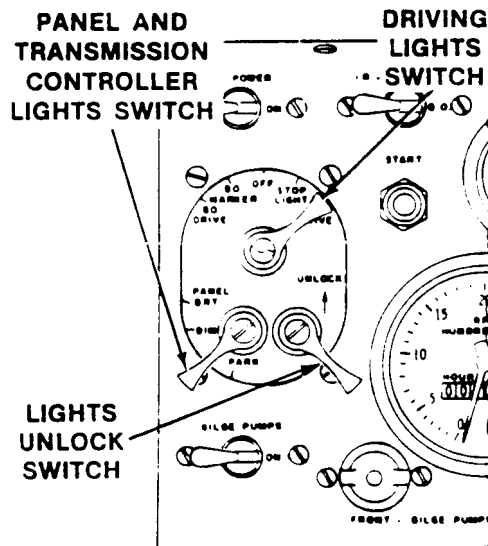

OPERATE WHITE DOME LIGHTS

1. Press blackout release button. Turn light selector switch past stop toward edge of dome light.
2. Press blackout release button. Turn light selector switch past stop to off position.

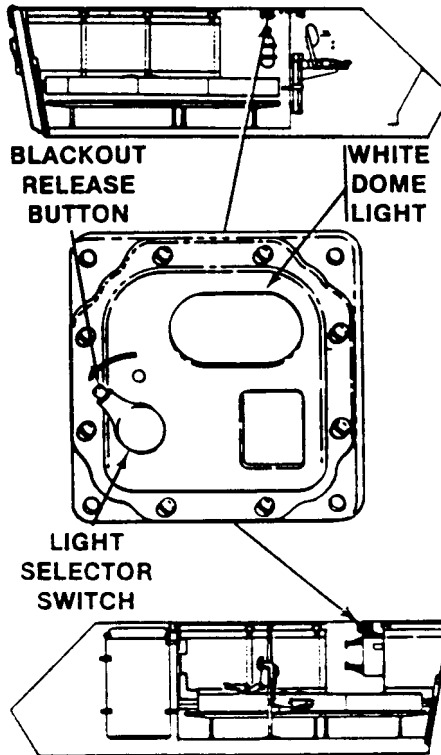

OPERATE BLACKOUT DOME LIGHTS

1. Turn light selector switch toward center of dome light.
2. Turn light selector switch to off position.

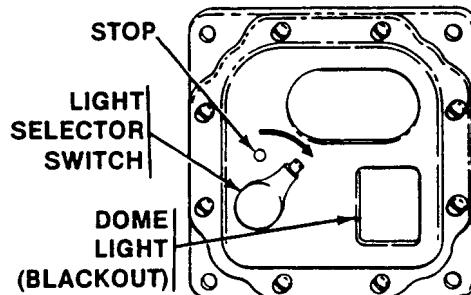

END OF TASK

OPERATE FIXED FIRE EXTINGUISHER SYSTEM

0031 00

THIS WORK PACKAGE COVERS:

- Operate Fixed Fire Extinguisher (Outside) (page 0031 00-2).
 - Operate Fixed Fire Extinguisher (Inside) (page 0031 00-3).
-

INITIAL SETUP:

Maintenance Level

Operator

References

TM 3-1040-285-10

Personnel Required

Driver or soldier

Equipment Condition

Fire extinguisher installed and seal unbroken

WARNING

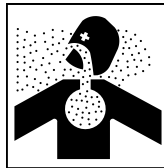

If CO2 is discharged into engine compartment while engine is running, engine exhaust may be poisonous. Poisonous gas can injure you. Stop engine before you discharge CO2. If CO2 is discharged while engine is running, do not breathe engine exhaust.

WARNING



Engine fan can blow away CO2 before fire is extinguished. Personnel can get burned. Equipment can get damaged. Stop engine before you operate fire extinguisher.

NOTE

Notify unit maintenance after fixed fire extinguisher is discharged.

OPERATE FIXED FIRE EXTINGUISHER (OUTSIDE)

NOTE

There are two fixed fire extinguishers; one for the engine compartment in all vehicles and one for the turbine compartment in the M58. Both outside fire extinguishers are operated the same way.

1. Shut down operating equipment if possible. See WP 0024 00 or TM 3-1040-285-10.
2. Pull outside fire extinguisher handle to activate fire extinguisher.

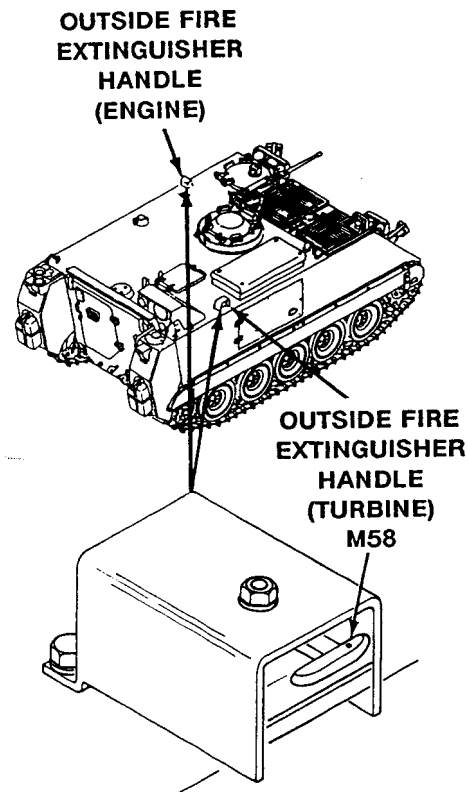

OPERATE FIXED FIRE EXTINGUISHER (INSIDE)

1. Shut down operating equipment if possible. See WP 0024 00 or TM 3-1040-285-10.

NOTE

Fixed fire extinguisher inside release is not the same in all carriers. If your carrier has a release handle, go to Step 2. If your carrier has a release knob, go to Step 3.

2. Remove safety pin and rotate fixed fire extinguisher handle upward to activate fire extinguisher.
3. Turn fixed fire extinguisher knob to the left to activate fire extinguisher.

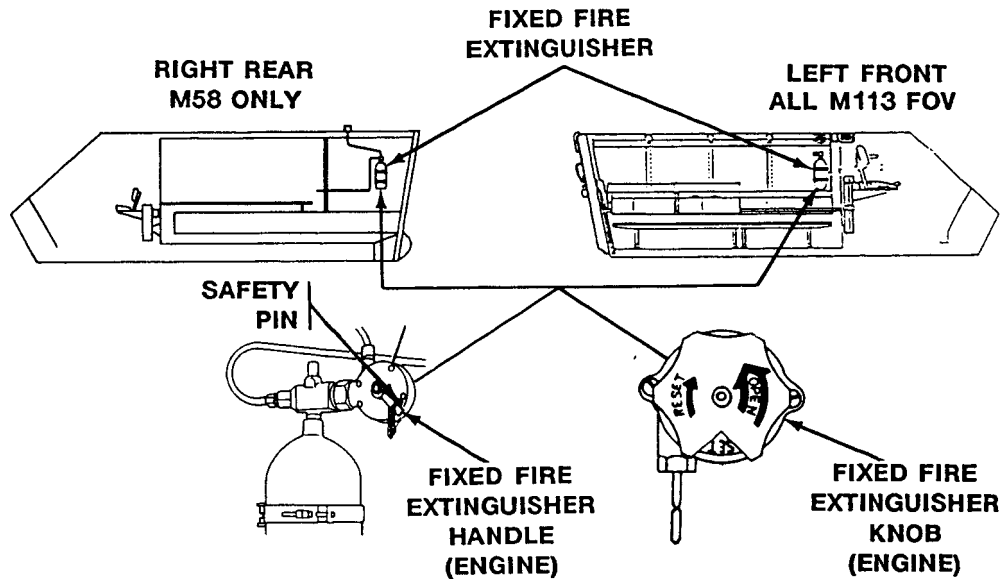

END OF TASK

OPERATE PORTABLE FIRE EXTINGUISHER

0032 00**THIS WORK PACKAGE COVERS:**

Operate Portable Fire Extinguisher (page 0032 00-1).

INITIAL SETUP:Maintenance Level

Operator

Personnel Required

Driver or soldier

OPERATE

WARNING



Fire extinguisher CO2 can cause suffocation and/or severe burns. Handle the fire extinguisher carefully. Do not bang or drop cylinder.

1. For all except M1068A3, open two clamps and remove portable fire extinguisher from stowed position in personnel compartment.
2. For M1068A3 only, pull latch and remove fire extinguisher from the bracket.

WARNING



Do not touch cone when using extinguisher. Hands will be severely burned.

3. To operate fire extinguisher:
 - a. Break fire extinguisher seal and remove safety pin from handle.
 - b. Point cone at base of fire.
 - c. Squeeze handles.
4. Return empty fire extinguisher to unit maintenance.

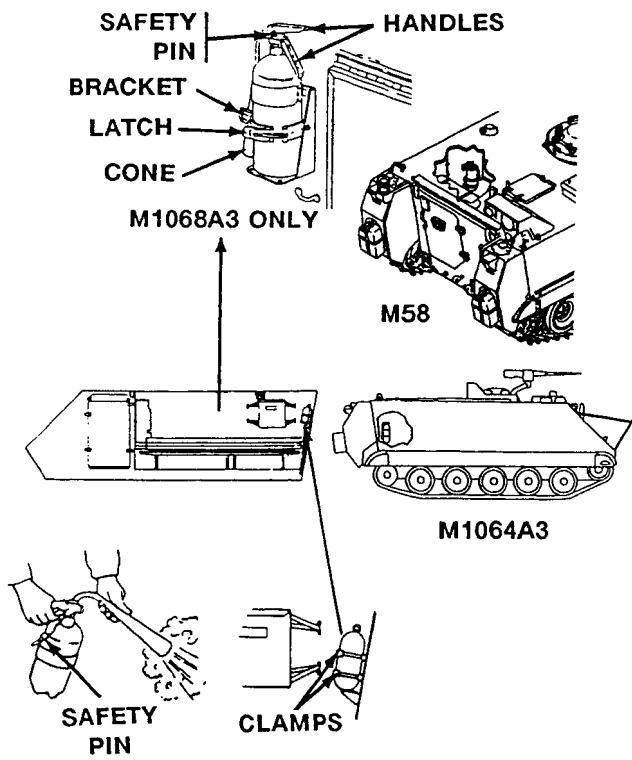

END OF TASK

INSTALL/REMOVE M17 PERISCOPES

0033 00

THIS WORK PACKAGE COVERS:

Install M17 Periscopes (page 0033 00-1).
Remove M17 Periscopes (page 0033 00-5).

INITIAL SETUP:

Maintenance Level

Operator

Equipment Condition

Engine stopped (WP 0024 00)

Personnel Required

Driver

INSTALL M17 PERISCOPES

NOTE

All M17 periscopes are installed the same way except the periscope mounted over the warning lights panel. Steps 3 - 5 tell how to install periscope over warning lights panel.

1. Push M17 periscope straight up into channel in driver's bulkhead or commander's cupola.
2. Tighten two thumbscrews to secure periscope in place.

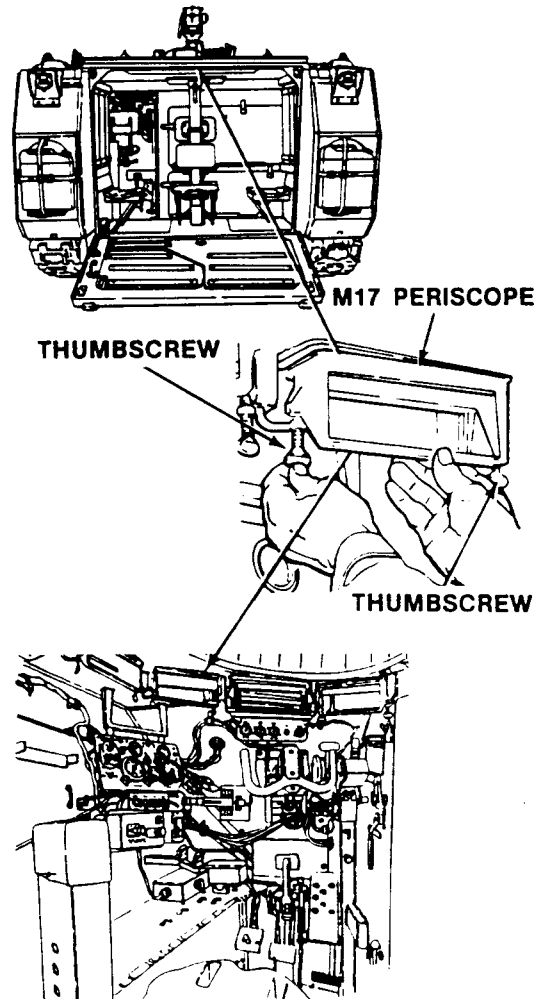

3. Loosen two thumbscrews. Swing and hold warning lights panel out of the way.

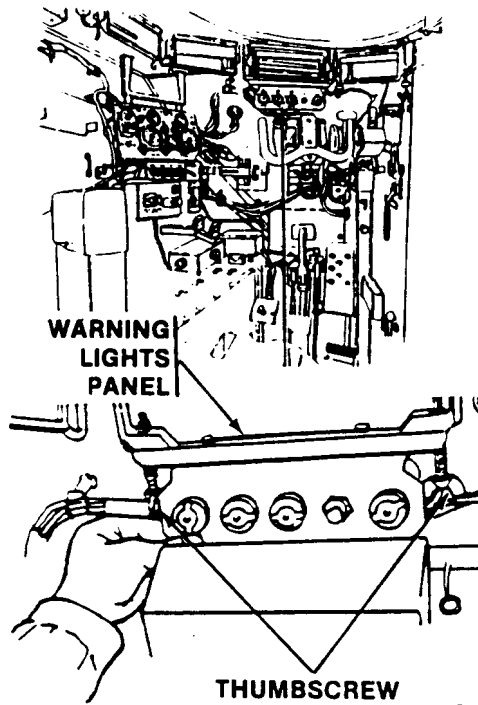

4. Install periscope in channel.
5. Return warning lights panel to normal position. Tighten two thumbscrews to secure periscope and warning lights panel in place.

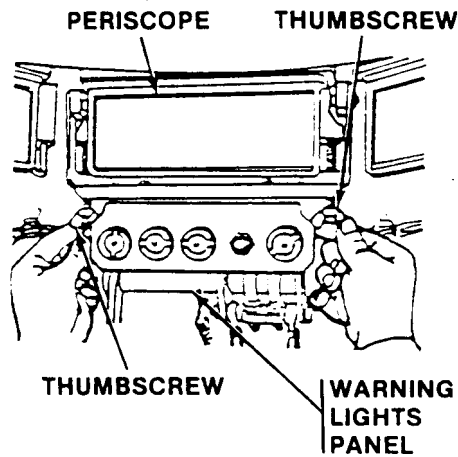

6. During blackout operations, cover periscope window with blackout cover located behind each periscope.

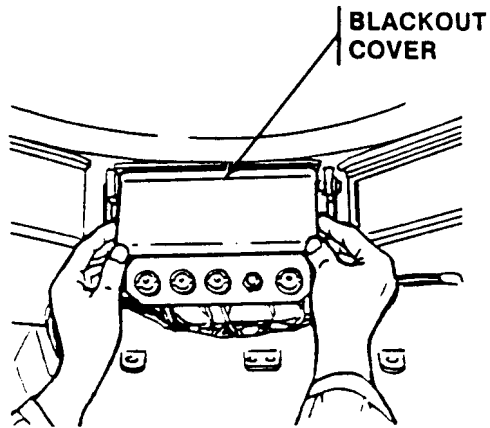

REMOVE M17 PERISCOPES

NOTE

All M17 periscopes are removed the same way except the periscope mounted over the warning lights panel. Step 3 and Step 4 tell how to remove periscope from over warning lights panel.

1. If installed, remove blackout cover from periscope window and stow on back of periscope.
2. Loosen two thumbscrews and remove periscope from channel in driver's bulkhead or commander's cupola.

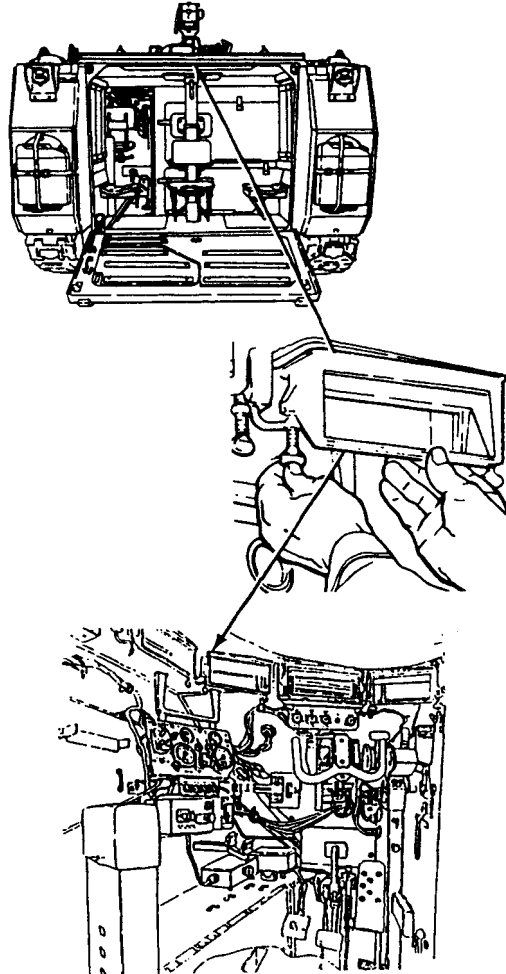

3. Loosen two thumbscrews. Swing warning lights panel out of the way and remove periscope from channel.
4. Return warning lights panel to normal position.

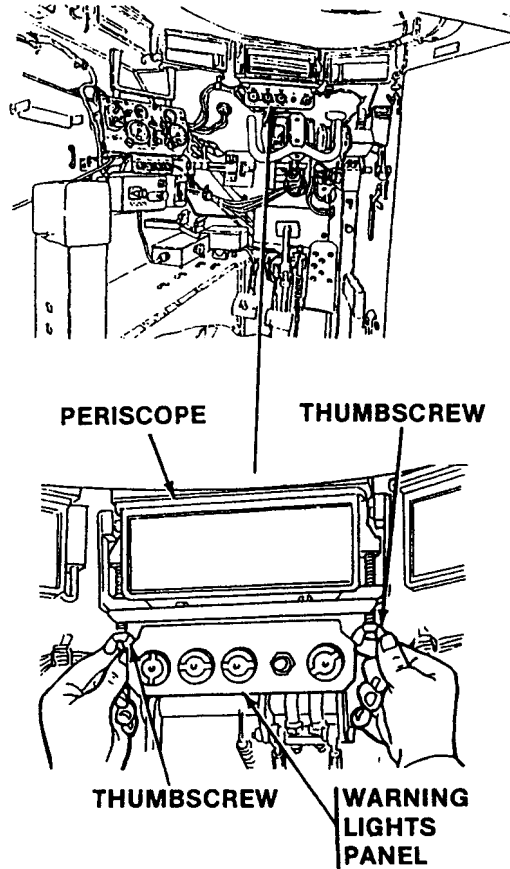

END OF TASK

INSTALL/REMOVE AN/VVS-2(V)1A DRIVER'S NIGHT VISION (ALL EXCEPT M58) 0034 00

THIS WORK PACKAGE COVERS:

- Install AN/VVS-2(V)1A Driver's Night Vision (page 0034 00-1).
- Remove AN/VVS-2(V)1A Driver's Night Vision (page 0034 00-5).

INITIAL SETUP:

Maintenance Level
Operator

References
TM 11-5855-249-10

Materials/Parts
Wiping rag (WP 0104 00, Item 15)

Equipment Condition
Carrier stopped

Personnel Required
Driver

INSTALL AN/VVS-2(V)1A DRIVER'S NIGHT VISION

1. Remove strap assembly, stowage cover, entrance window cover, and driver's night vision (AN/VVS-2(V)1A) from stowage bracket.

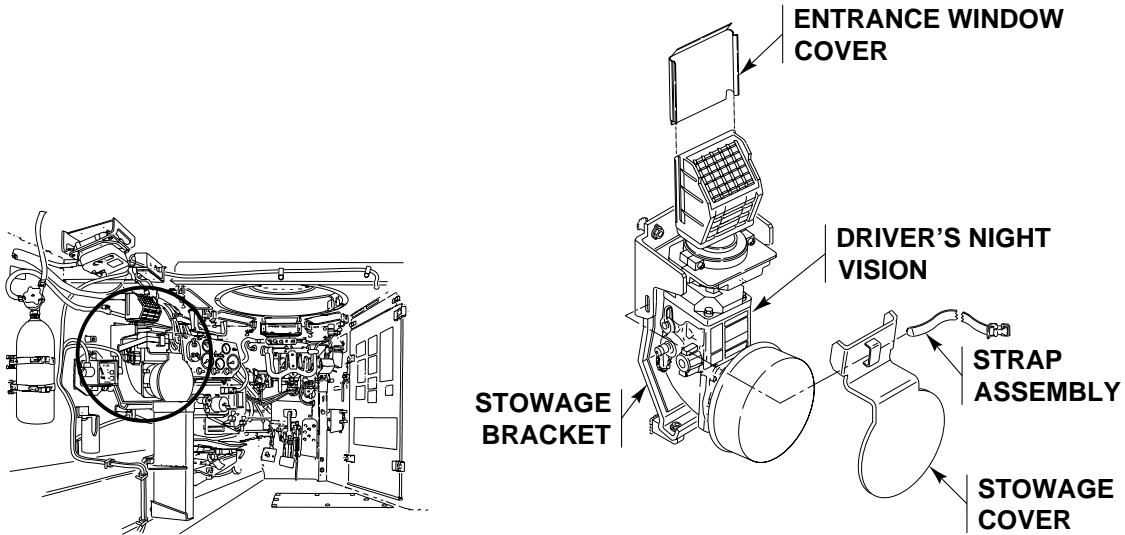

2. Loosen two viewer handles on viewer adapter mount and slide rear cleat by pulling back handle. Tilt plug assembly to remove from viewer adapter mount in hatch.
3. Stow plug in Basic Issue Items bag. Stow bag in a suitable place in the vehicle.
4. Install strap assembly, stowage cover, and entrance window cover on stowage bracket.

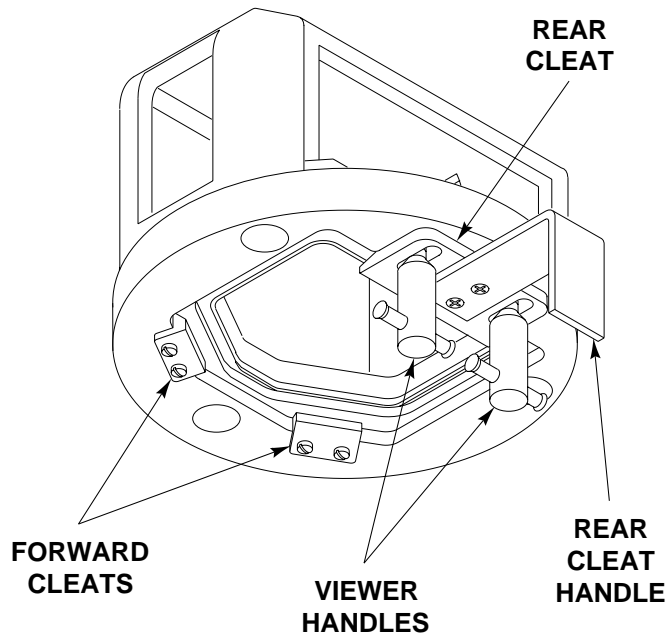

5. Check to see that driver's night vision is in center detent position so that mount assembly is square with the side of the entrance window housing. If not, rotate it in its mount until it stops in center detent position.
6. Hold driver's night vision in an upright position with the window pointing forward and then push entrance window carefully through viewer adapter mount in hatch.

7. Engage forward edge of driver's night vision mount into forward cleats on forward edge of the viewer adapter mount on the driver's hatch.
8. Push driver's night vision forward and firmly while tilting rear edge up.
9. Slide rear cleat forward by pushing handle as far as it will go and hand tighten two viewer handles.
10. Check for secure mounting by simultaneously twisting and pulling down on driver's night vision.
11. Check for free rotation of driver's night vision.

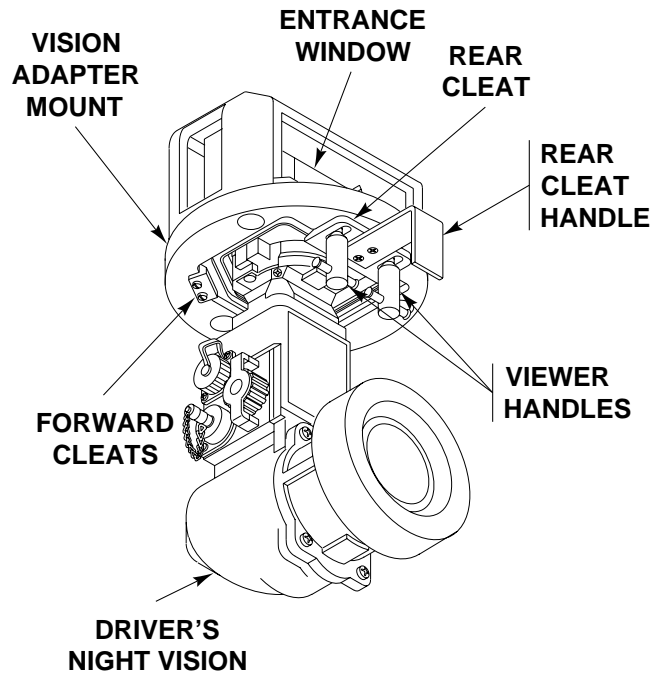

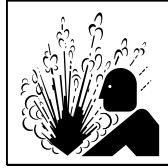
WARNING

Remove 2.7 volt battery from battery compartment before connecting driver's night vision power cable. The 2.7 volt battery may explode if not removed before the connection is made. Personnel may be injured if battery explodes.

12. Rotate OFF/BRIGHT rotary switch to OFF.
13. Unscrew battery compartment cap and remove 2.7 volt battery. Reinstall battery compartment cap.

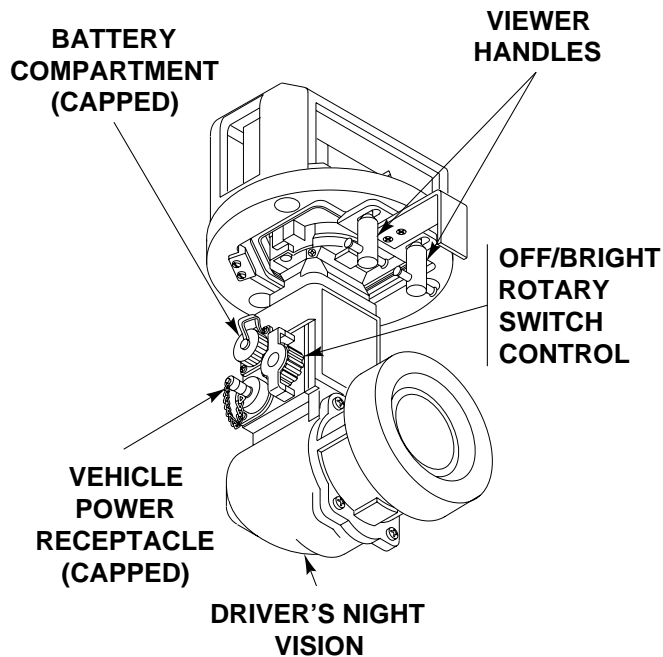

14. Remove night vision power cable from stowage receptacle on master switch panel.
15. Remove cap from driver's night vision power receptacle and connect vision power cable plug to power receptacle.

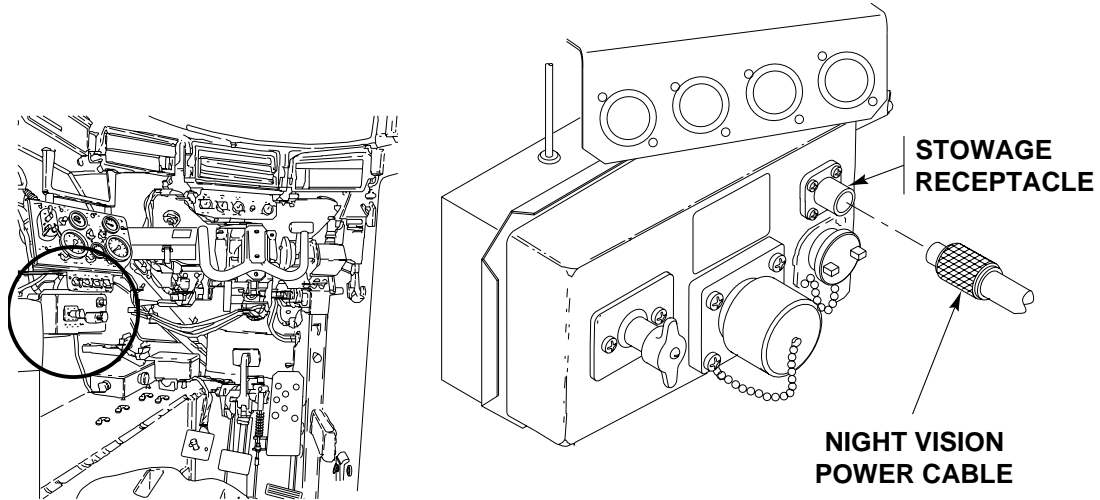

REMOVE AN/VVS-2(V)1A DRIVER'S NIGHT VISION

1. Rotate OFF/BRIGHT rotary switch to OFF.
2. Disconnect vision power cable from driver's night vision and reinstall power cable connector cap.
3. Connect night vision power cable to stowage receptacle on master switch panel.

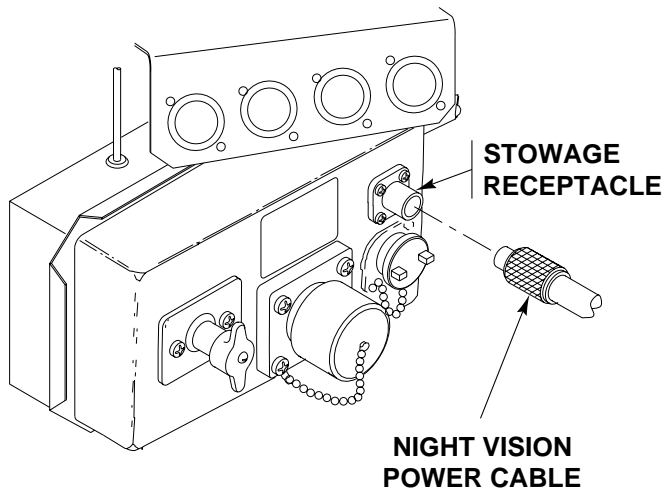

4. Stow excess cable behind fixed fire extinguisher tubing.
5. Rotate driver's night vision to straight-ahead (detent) position.
6. Hold driver's night vision firmly, while loosening two viewer handles, slide rear cleat back.

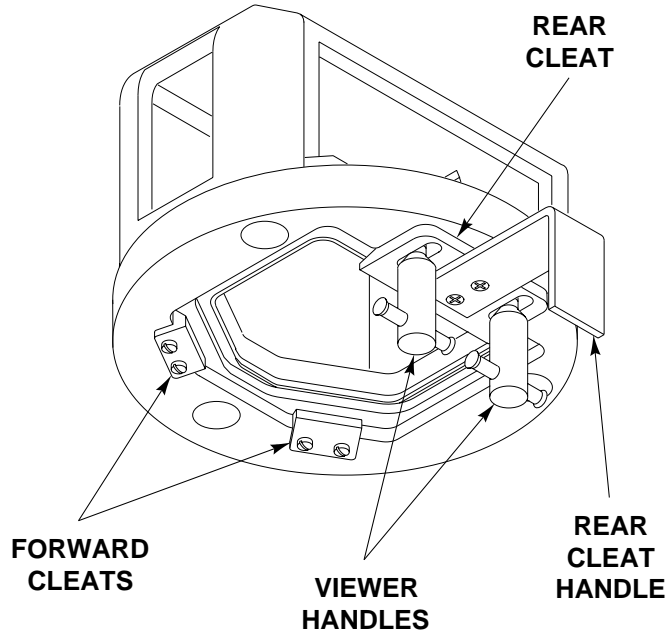

7. Tilt the eyepiece end forward and carefully lower driver's night vision.
8. Carefully wipe off any dirt or moisture from driver's night vision.
9. Remove strap assembly, plug, stowage cover, and entrance window cover from stowage bracket.
10. Install driver's vision in stowage bracket and secure with strap assembly stowage cover and entrance window cover.
11. Install plug assembly in vision adapter mount and secure with rear cleat and two viewer handles.

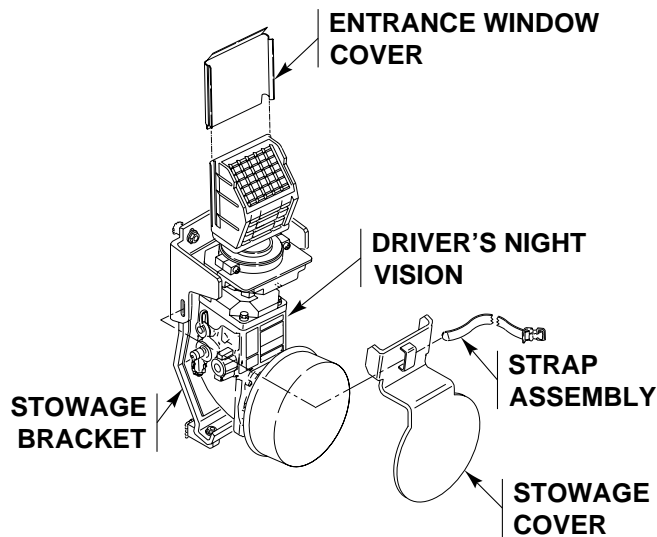

END OF TASK

OPERATE AN/VVS-2(V)1A DRIVER'S NIGHT VISION (ALL EXCEPT M58)

0035 00

THIS WORK PACKAGE COVERS:

- Operate AN/VVS-2(V)1A Driver's Night Vision With Carrier Power (page 0035 00-1).
- Operate AN/VVS-2(V)1A Driver's Night Vision With 2.7 Volt Battery (page 0035 00-5).

INITIAL SETUP:

Maintenance Level

Operator

References

TM 11-5855-249-10

Personnel Required

Driver

Equipment Condition

Driver's night viewer installed (WP 0034 00)

Materials/Parts

- Lens tissue
- Lens cleaning solution
- 2.7 volt battery

OPERATE DRIVER'S NIGHT VISION WITH CARRIER POWER

CAUTION

Reinstall entrance window protective cover during bright light conditions (daylight, stopped in lighted staging area).

Be aware that 2.7 volt battery can explode and damage driver's night viewer. Check that 2.7 volt battery is removed from driver's night vision before operating driver's night vision with carrier power.

1. Remove entrance window cover and eyepiece protective cap.

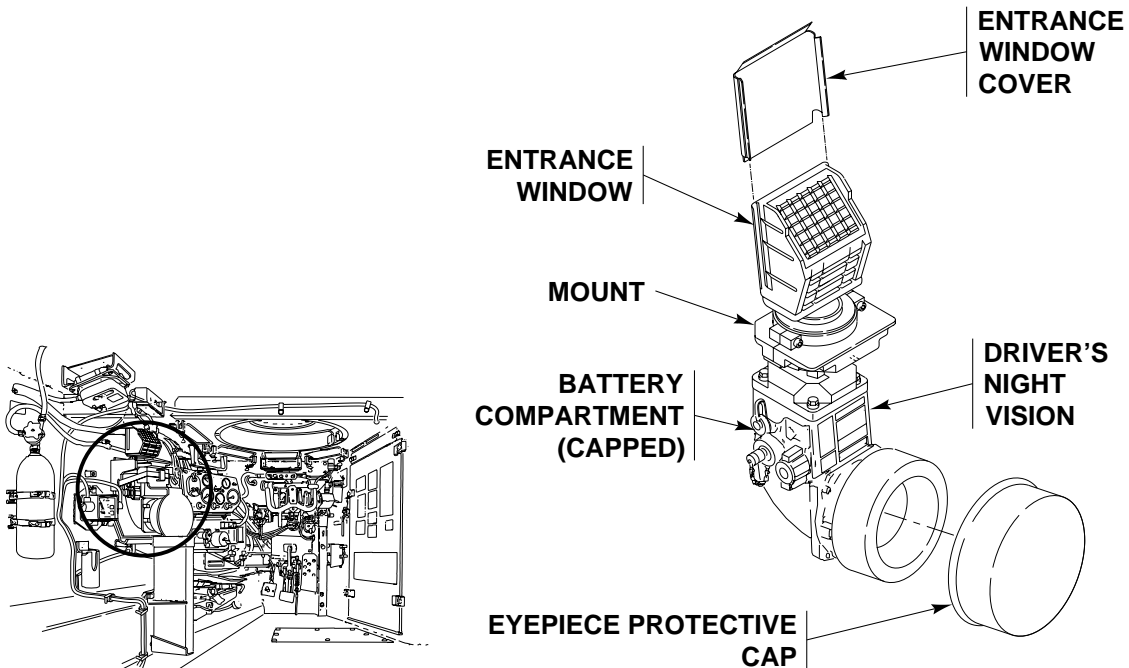

2. Return eyepiece protective cap and entrance window cover to stowage bracket.

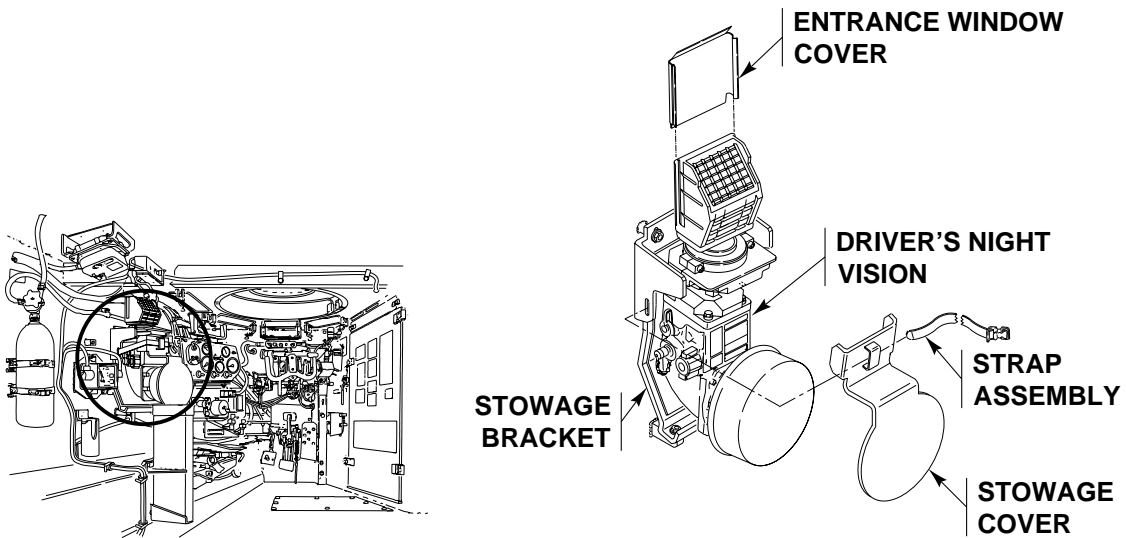

3. Adjust driver's seat for comfortable viewing at eyepiece (WP 0013 00).
4. Turn MASTER SWITCH ON.

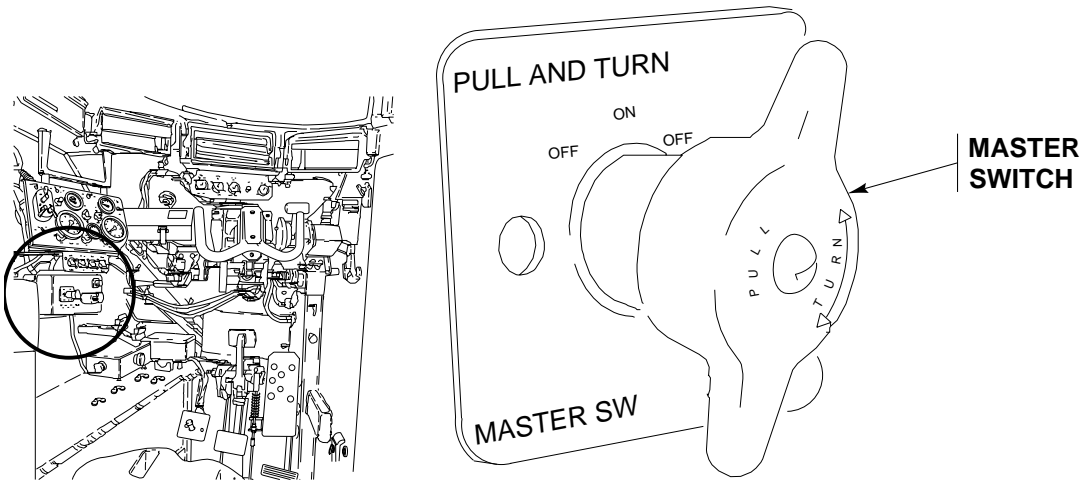

5. Move DNV POWER switch to ON.
6. Move driving lights switch to BO DRIVE.
7. Move BO SELECT switch to OFF.

8. Rotate OFF/BRIGHT rotary switch to maximum clockwise bright (ON) position and note that a green image is visible in the eyepiece.

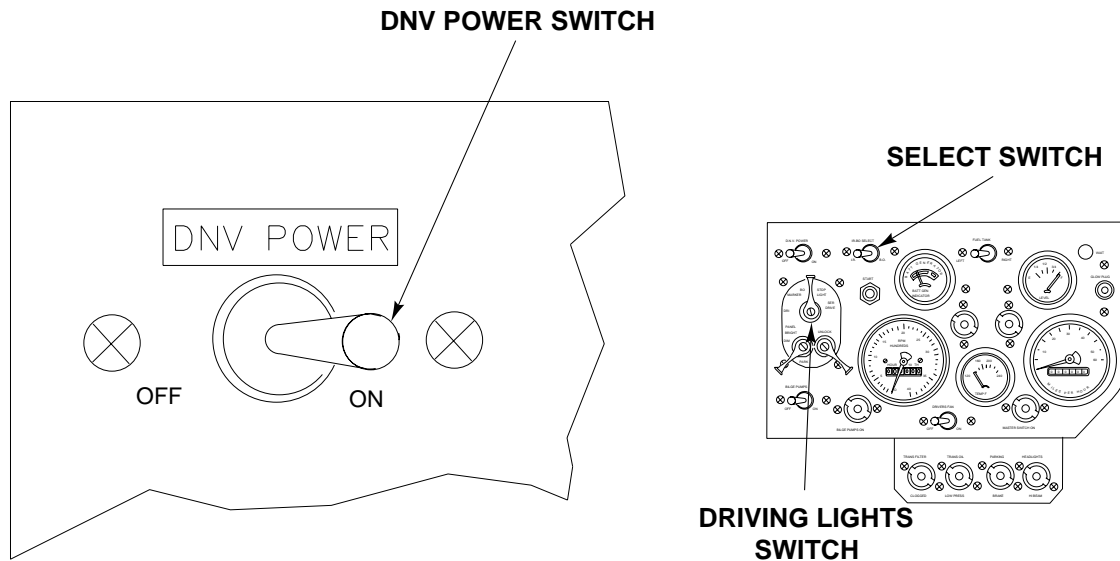

NOTE

The OFF/BRIGHT rotary switch normally is set to maximum clockwise bright (ON) position when viewing dim images. However, if the image display is too bright, contrast will be degraded. Therefore, adjust brightness for best contrast.

9. Set driver's night vision in straight-ahead (detent) position for normal driving.
10. When slowly turning carrier or when turning it from a stopped position, driver's night vision can be rotated out of detent position by twisting it firmly.
11. If operator normally wears reading glasses, use them while operating driver's night vision, because image appears 20 inches away which is normal reading distance.
12. If light outside increases, reinstall entrance window protective cover.

CAUTION

Do not open driver's hatch with vision power connected. The driver's night vision power cable is not long enough.

NOTE

Before cleaning entrance window with lens tissue and lens cleaner, gently remove excess dirt and dust from entrance window.

13. If entrance window becomes rain spotted or dusty, maintain good visibility by first removing driver's night vision from carrier mount.
14. Clean entrance window with lens tissue folded into a swab and moistened with lens cleaner, using circular motion.
15. Dry entrance window with a clean dry lens tissue, using circular motion.
16. Move driving lights switch to OFF.
17. Move DNV POWER switch to OFF.

18. Turn MASTER SWITCH OFF.
19. Install entrance window cover and eyepiece protective cap on driver's night vision.

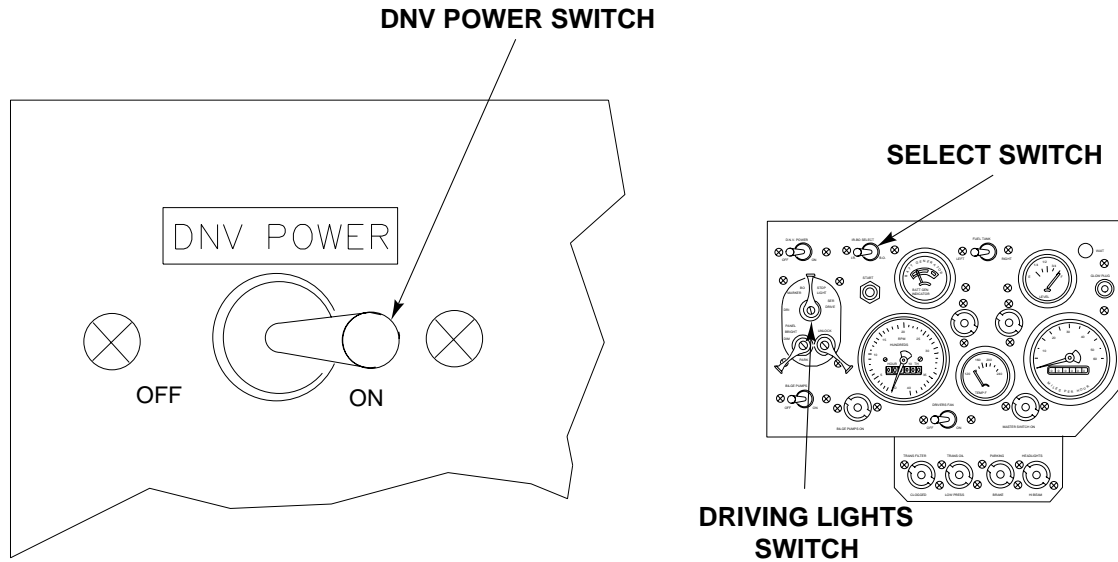

OPERATE DRIVER'S NIGHT VISION WITH 2.7 VOLT BATTERY

1. Remove entrance window cover and eyepiece protective cap.
2. Return eyepiece protective cap and entrance window cover to stowage bracket.

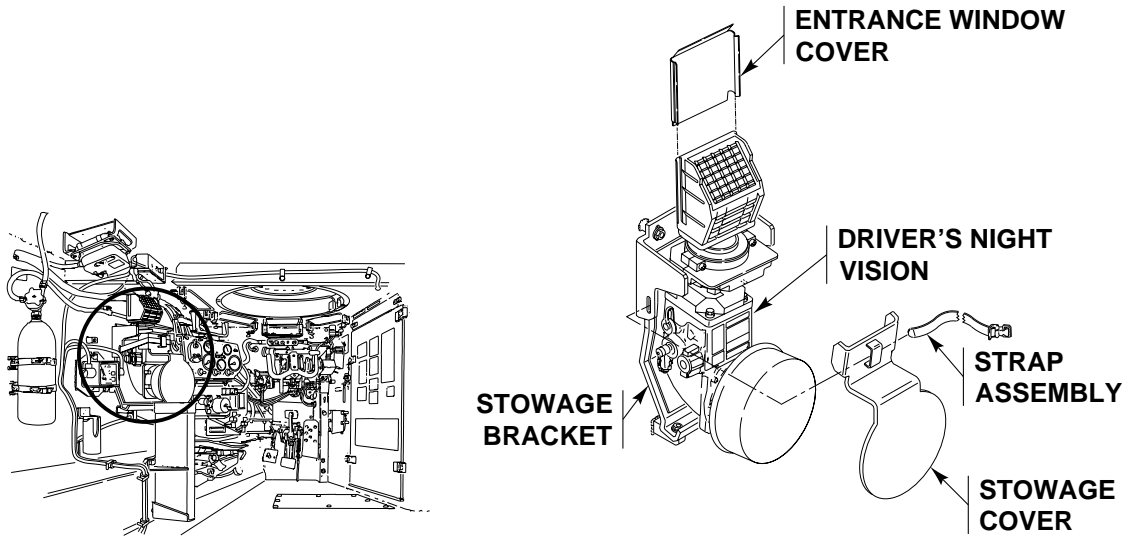

3. Remove driver's night vision power cable from driver's night vision.
4. Connect driver's night vision power cable to stowage receptacle on master switch panel.
5. Install power cable receptacle cap on driver's night vision.
6. Remove battery compartment cap and insert 2.7 volt battery with recessed end (+) first into battery compartment.

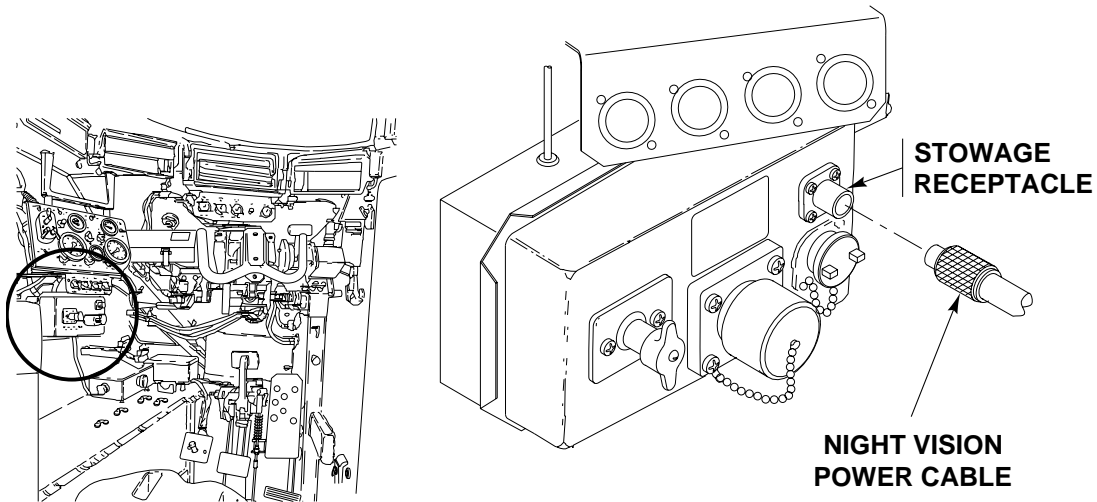

NOTE

The recessed end of the 2.7 volt battery is the positive end (+). Finger-tighten battery compartment cap securely to ensure firm contact with battery.

7. Finger tighten battery compartment cap securely to ensure firm contact with 2.7 volt battery.
8. Adjust driver's seat for comfortable viewing at eyepiece.

9. Rotate OFF/BRIGHT rotary switch to maximum clockwise bright (ON) position and note that a green image is visible in the eyepiece. Adjust driver's seat for comfortable viewing at eyepiece.

NOTE

The OFF/BRIGHT rotary switch normally is set to the maximum clockwise bright (ON) position when viewing dim images. However, if the image display is too bright, contrast will be degraded. Therefore, adjust brightness for best contrast.

10. Set driver's night vision in straight-ahead (detent) position for normal driving.
11. When slowly turning carrier or when turning it from a stopped position, driver's night vision can be rotated out of detent position by twisting it firmly.
12. If operator normally wears reading glasses, use them while operating driver's night vision because image appears 20 inches away, which is normal reading distance.
13. If light outside increases, reinstall entrance window protective cover.

NOTE

Before cleaning entrance window with lens tissue and lens cleaner, gently remove excess dirt and dust from entrance window.

14. If entrance window becomes rain spotted or dusty, maintain good visibility by first removing driver's night vision from carrier mount.
15. Clean entrance window with lens tissue folded into a swab and moistened with lens cleaner, using circular motion.
16. Dry entrance window with a clean dry lens tissue, using circular motion.
17. Rotate OFF/BRIGHT rotary switch to OFF.
18. Install entrance window cover and eyepiece protective cap on driver's night vision.
19. Unscrew battery compartment cap and remove 2.7 volt battery from driver's night vision.

NOTE

Normal battery life is 6 to 8 hours. Discard 2.7 volt battery after each night's operation.

20. Replace battery compartment cap on driver's night vision.

END OF TASK

**INSTALL/REMOVE AN/VAS-5 DRIVER'S VISION ENHANCER
(DVE) (M58 ONLY)**

0035 01

THIS WORK PACKAGE COVERS:

Installation (page 0035 01-1).
Removal (page 0035 01-4).

INITIAL SETUP:

Maintenance Level

Operator

Equipment Condition

Carrier stopped

Personnel Required

Driver

INSTALLATION

1. Remove or loosen strap securing the DVE Sensor in the stowage bracket. Remove the DVE Sensor from the stowage bracket. Remove the entrance window cover from the DVE Sensor and stow in the stowage bracket.

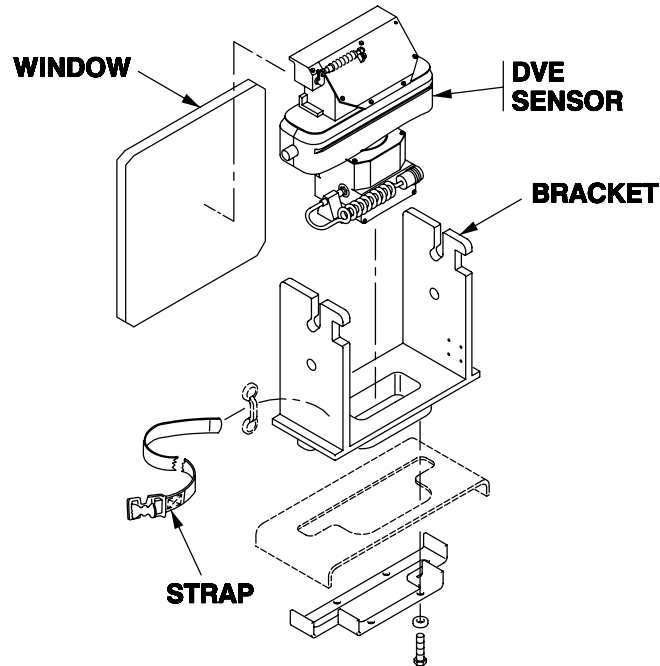

**INSTALL/REMOVE AN/VAS-5 DRIVER'S VISION ENHANCER (DVE)
(M58 ONLY) — Continued**

0035 01

2. Squeeze latches and push up on plug assembly to release plug from quick release. Tilt plug assembly to remove through opening in quick release. Stow the plug assembly in the stowage bracket.

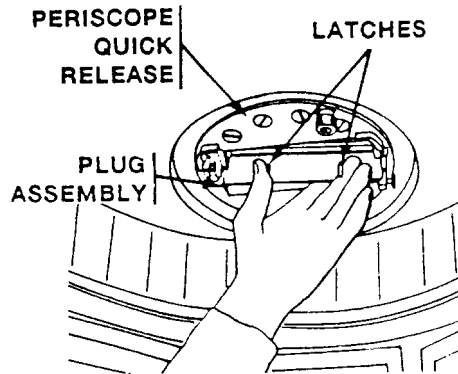

3. Push two latches upward and lock in position with thumbscrews.

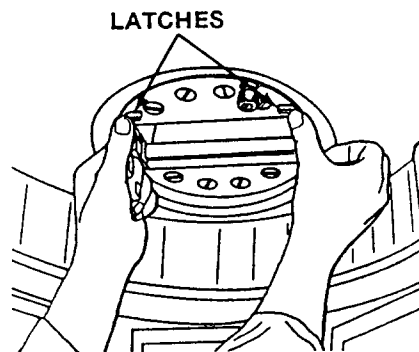

4. Ensure the azimuth control handle on the mounting plate is engaged in the azimuth lock and the retainer release latches are pressed fully upward to open night vision enhancer jaws. If not, rotate until it stops in the azimuth lock position.

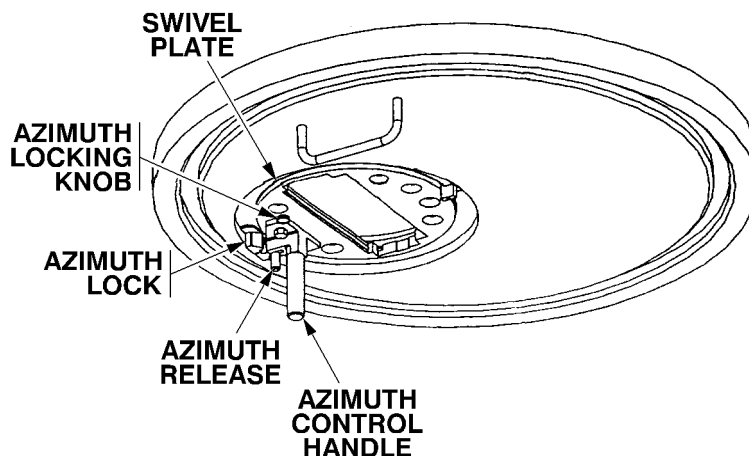

**INSTALL/REMOVE AN/VAS-5 DRIVER'S VISION ENHANCER (DVE)
(M58 ONLY) — Continued**

0035 01

5. Hold driver's vision enhancer in an upright position with the window pointing forward and push entrance window carefully through mounting plate in driver's hatch.

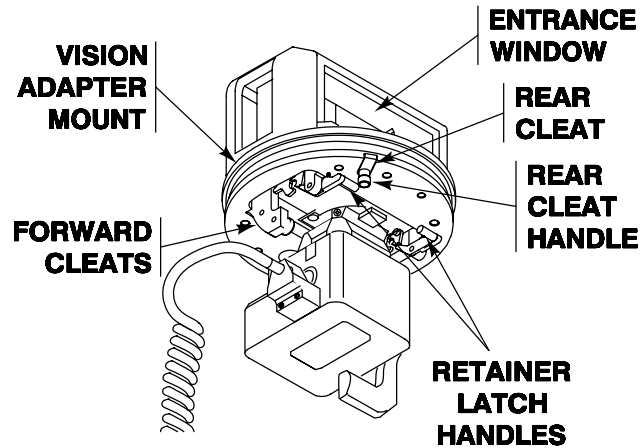

6. Engage cleats of driver's vision enhancer into retainers of mounting plate on driver's hatch.
7. Push driver's vision enhancer upward and firmly until driver's vision enhancer fully engages mounting plate retainers.
8. Check for secure mounting by simultaneously twisting and pulling down on driver's vision enhancer.
9. Check for free rotation of driver's vision enhancer and that azimuth control operates freely and correctly.
10. Ensure DRIVER'S VISION ENHANCER POWER switch is in OFF position.
11. Connect vision power cable plug to power receptacle on panel.

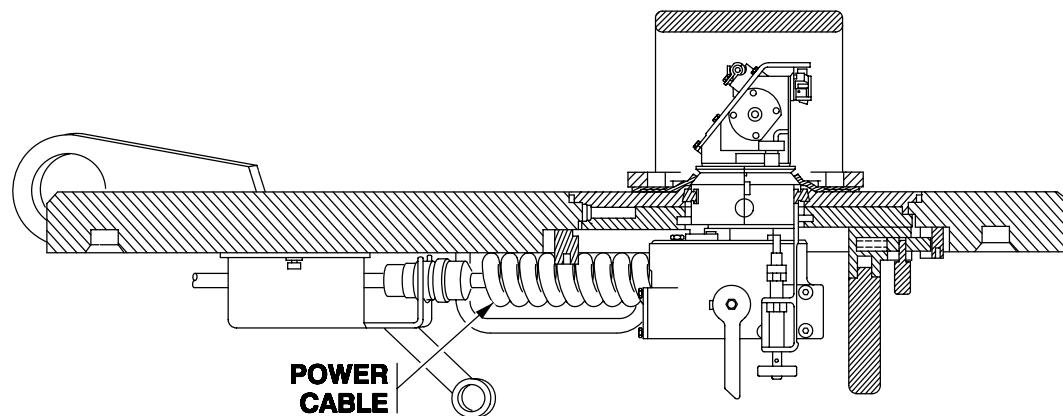

**INSTALL/REMOVE AN/VAS-5 DRIVER'S VISION ENHANCER (DVE)
(M58 ONLY) — Continued**

0035 01

REMOVAL

1. Turn POWER switch to OFF.
2. Disconnect vision power cable from power receptacle on panel.

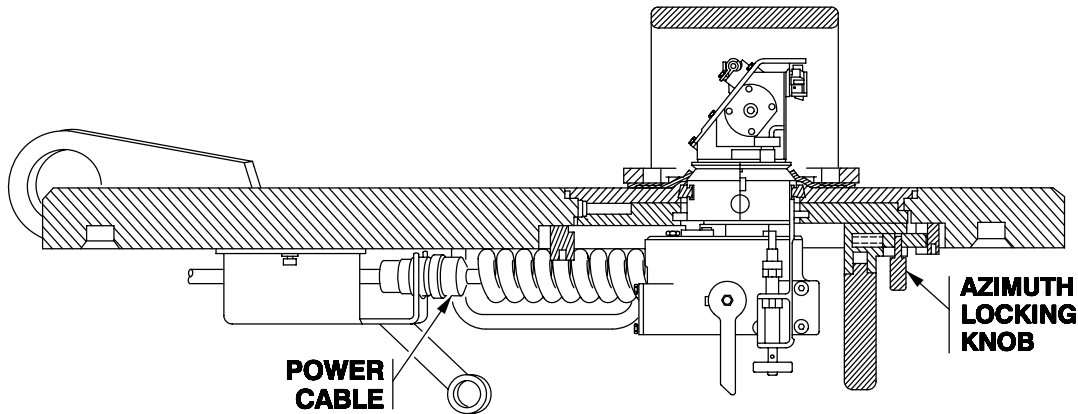

3. Rotate driver's vision enhancer to straight-ahead azimuth lock position and secure azimuth locking knob.
4. Hold driver's vision enhancer firmly, while pressing two retainer latch handles upward.

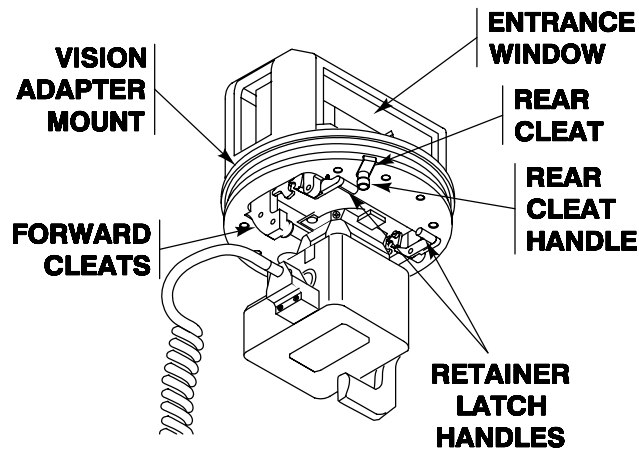

5. Carefully lower driver's vision enhancer from retainers and mounting plate in driver's hatch.
6. Carefully wipe off any dirt or moisture from driver's vision enhancer.
7. Remove strap assembly and plug from stowage bracket.

**INSTALL/REMOVE AN/VAS-5 DRIVER'S VISION ENHANCER (DVE)
(M58 ONLY) — Continued**

0035 01

8. Install driver's vision enhancer in stowage bracket and secure with strap assembly.

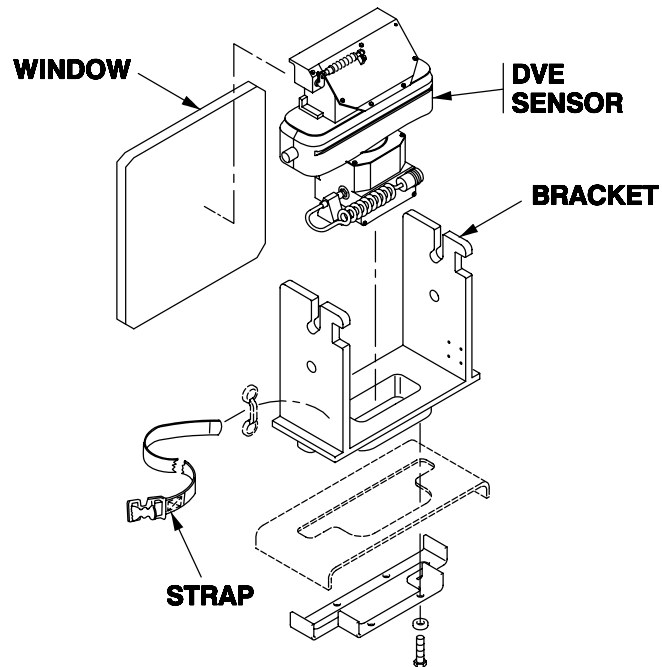

9. Insert plug assembly through the top of opening in the periscope release.
10. Squeeze latches on plug assembly and align pins in the plug assembly with the opening in the periscope quick release. Release latches to secure plug assembly in periscope quick release.

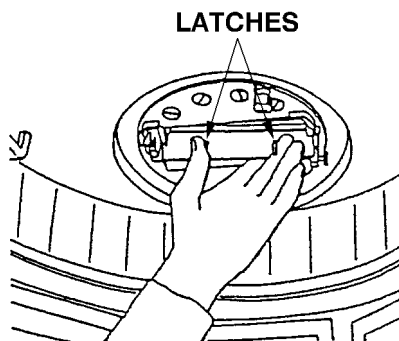
**END OF TASK**

OPERATE AN/VAS-5 DRIVER'S VISION ENHANCER (DVE) (M58 ONLY)

0035 02

THIS WORK PACKAGE COVERS:

- Preparation (page 0035 02-1).
 - Operate (page 0035 02-3).
 - Shutdown (page 0035 02-8).
-

INITIAL SETUP:

Maintenance Level

Operator

Personnel Required

Driver

Materials/Parts

- Lens tissue (WP 0104 00, Item 14)
- Lens cleaner (WP 0104 00, Item 16)

Equipment Condition

Driver's viewer enhancer installed (WP 0035 01)

PREPARATION

CAUTION

Reinstall entrance window protective cover during bright light conditions (daylight, stopped in lighted staging area).

1. Remove entrance window cover/eyepiece protective cap.

ENTRANCE WINDOW COVER

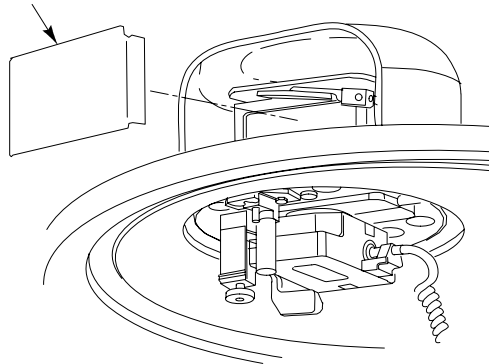

NOTE

For all controls and indicators identified in this section, refer to Description and Use of Operator's Controls and Indicators (WP 0004 00).

Before applying power to unit, ensure that the following control positions are as indicated in the following steps.

Before operating the vehicle, ensure that the DVE azimuth and elevation controls are positioned in the locked straight-ahead and level 0 degree detent viewing positions. This will ensure that the driver is looking straight ahead when operating the vehicle.

Drive **ONLY** in the straight-ahead and level 0 degree detent viewing position.

2. Unstow the driver's/commander's display as required, by pulling display adjustment knobs out and positioning display in the viewing position.

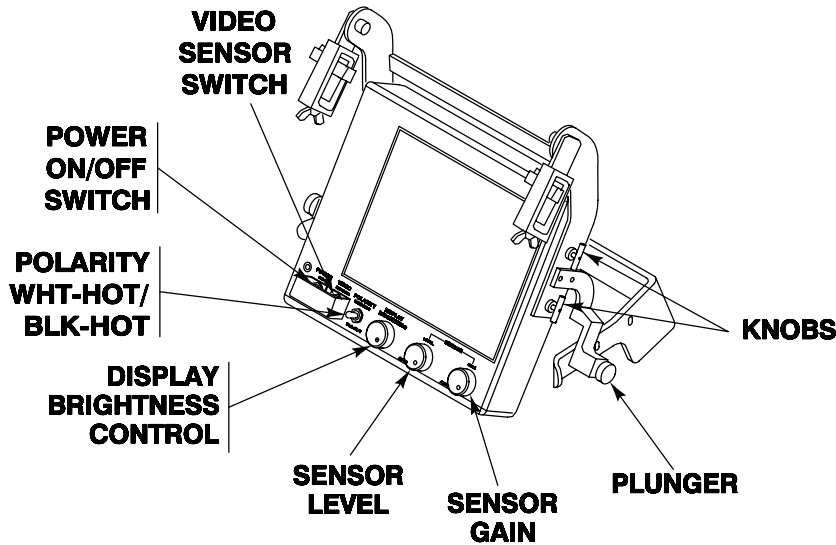

3. Ensure azimuth and elevation controls are in straight-ahead and level 0 degree detent position. Ensure that the Azimuth Locking Knob is locked, securing the swivel plate in place.

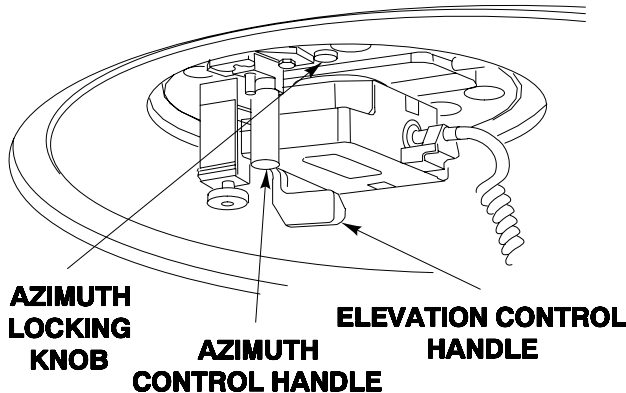

4. Set DVE POWER switch to OFF (down position).
5. Set VIDEO switch to SENSOR (up position).
6. Set POLARITY switch to WHT-HOT (up position).
7. With DISPLAY BRIGHTNESS control turned fully counterclockwise, rotate knob approximately 1/4 turn clockwise.
8. Set SENSOR LEVEL and GAIN controls to full counterclockwise (AUTO) detent position.

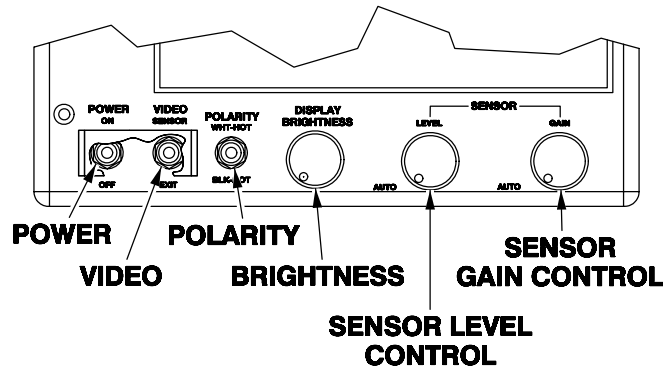

OPERATE

WARNING

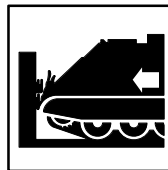

Before operating the vehicle, ensure that the DVE azimuth control is in the locked position. This will ensure that the DVE is looking straight ahead when operating the vehicle. Failure to do so may result in personnel injury and/or damage to the equipment.

WARNING

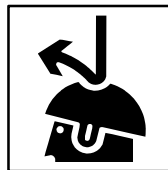

Helmets must always be worn when driving with the DVE installed. The DVE display should be removed from its mount when not in use for extended driving operations to minimize the risk of head strike injuries.

NOTE

Refer to Description and Use of Operator's Controls and Indicators for control locations and their function (WP 0004 00).

1. Ensure the VEHICLE MASTER POWER switch and the DVE POWER switch are set to ON.

NOTE

The time necessary for the system electronics to stabilize depends on ambient temperature. As ambient temperature rises or cools, the stabilizing time changes slightly.

The words “NO SENSOR VIDEO CHECK VIDEO SWITCH” will appear on the display only if the VIDEO switch is in the EXT position or the display circuitry has no video input. If the video returns, the words are removed.

2. Set POWER switch to ON (up position). The power light-emitting diode (LED) will illuminate. Allow five minutes for system electronics to stabilize for maximum image clarity.
3. Leave the VIDEO switch in the SENSOR (up position) for sensing input from the sensor to the display. For external input to the display, set switch to EXT (down position).
4. Adjust the seat height and/or Display Module to place the display at eye level. Loosen the two display adjustment knobs on both sides of the Display Module. Adjust the tilt of the Display Module either up or down. Retighten the adjustment knobs.

WARNING



If the display becomes degraded while driving the vehicle, such as the presence of dead pixels (the very small dots that make up the display image) and/or video noise that prevents the driver from performing his mission, then immediately bring the vehicle to a safe stop to avoid collision. If the problem cannot be fixed, report the situation to higher level maintenance.

NOTE

The DISPLAY BRIGHTNESS control should not be adjusted too high (saturated) or too low, or the scene may be uncomfortable to view and some useful video information may be lost. Also, with the control adjusted too high, you may reduce your eye's night vision capability and compromise light discipline.

If the ambient light within the vehicle changes, it may be necessary to compensate by readjusting the DISPLAY BRIGHTNESS control.

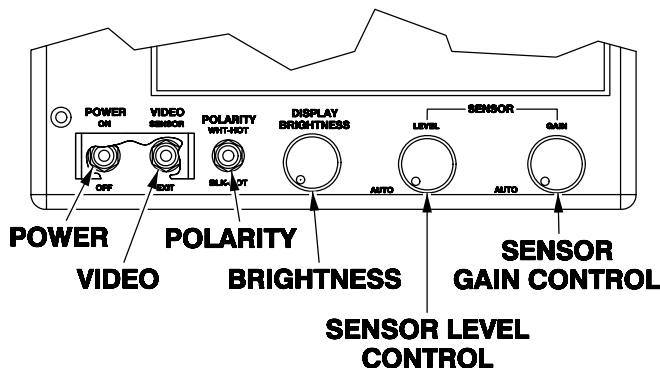

5. DISPLAY BRIGHTNESS Control — While viewing the display scene, adjust DISPLAY BRIGHTNESS control until scene brightness is suitable for operator viewing. It may be helpful to readjust the Display Module tilt and/or seat height for best viewing.

NOTE

The **SENSOR LEVEL** control is non-functional on the commander's display.

6. **SENSOR LEVEL** Control — The **SENSOR LEVEL** control is a dual-action control. The two functions are automatic and manual and are described as follows:

WARNING

The AUTO LEVEL and AUTO GAIN modes do not react instantly to rapidly changing scenery (shade to sun, sun to shade). The AUTO LEVEL and AUTO GAIN modes require one or two seconds to compensate. The automatic gain and level features will adjust faster than manual adjustments. If necessary, slow or stop vehicle.

- a. **AUTO LEVEL** — The **AUTO LEVEL** position provides the best image for most driving conditions. For **AUTO LEVEL** mode, the control must be in the full counterclockwise detent position. In the **AUTO** position, the sensor video brightness is adjusted automatically. In this position, the internal circuitry examines the **INFRARED** video scene, determines the hottest and coldest extremes and centers the video level accordingly. The **AUTO LEVEL** mode should normally be used while driving the vehicle.
- b. **Manual LEVEL** adjustment — When the vehicle is stationary, in some viewing conditions it may be helpful to adjust the **SENSOR LEVEL** control. Rotate the **SENSOR LEVEL** control clockwise out of detent position. Choose a scene within **DVEs FIELD OF VIEW (FOV)**. Adjust the **SENSOR LEVEL** control until the best image definition is obtained. The optimum level setting varies with the scene and background. This manual operation should only be used when the vehicle is stationary. It may be useful for viewing imagery having very high thermal difference scenes, such as nearby vehicles, factories, or fires. It is also useful for viewing low thermal difference scenes, such as featureless desert terrains or wet fields during or following a rain, where increased **LEVEL** control (using manual operation) may improve detail resolution.

NOTE

The **SENSOR GAIN** control is non-functional on the commander's display.

7. **SENSOR GAIN** Control — The **SENSOR GAIN** control is a dual-action control. The two functions are automatic and manual.

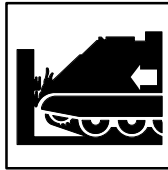
WARNING

The AUTO LEVEL and AUTO GAIN modes do not react instantly to rapidly changing scenery (shade to sun, sun to shade). The AUTO LEVEL and AUTO GAIN modes require one or two seconds to compensate. The automatic gain and level features will adjust faster than manual adjustments. If necessary, slow or stop vehicle.

- a. **AUTO GAIN** — The AUTO GAIN position provides the best image for driving conditions. For AUTO GAIN mode, the control must be in the full counterclockwise detent position. In the AUTO position, the sensor video gain is adjusted automatically. In this position, the internal circuitry examines the INFERRED video scene, determines the hottest and coldest extremes, and adjusts the video gain accordingly. The AUTO GAIN mode should normally be used while driving the vehicle.
- b. **Manual GAIN adjustment** — When the vehicle is stationary, in some viewing conditions it may be helpful to adjust the SENSOR GAIN control. Rotate the SENSOR GAIN control clockwise out of detent position. Choose a scene within DVEs FIELD OF VIEW (FOV). Adjust the SENSOR GAIN control until objects and background features range from near black to near white. At some settings it may be helpful to also make a slight readjustment of the SENSOR LEVEL control. The optimum gain setting varies with the scene and background. The manual operation should be used only when the vehicle is stationary. It may be useful for viewing imagery having very high thermal difference scenes, such as nearby vehicles, factories, or fires. It is also useful for viewing low thermal difference scenes, such as featureless desert terrains or wet fields during or after a rain, where increased gain (using manual operation) may enhance detail resolution.

NOTE

The POLARITY switch is non-functional on the commander's display.

NOTE

There are two short periods each day called crossover periods or diurnal cycle when most natural objects are about the same temperature. This is when they have cooled down at night and as they are heating up in the early morning. Since objects are near the same temperature, there is little temperature difference for the DVE to use, degrading the image display quality. This is also what happens when a heavy rain makes all natural objects close to the same temperature.

8. **POLARITY switch** — The scene polarity preference is selected by using the POLARITY switch. With the switch in WHT-HOT (up position), hot objects in the scene appear lighter on a darker background. With the switch in BLK-HOT (down position), hot objects in the scene appear darker on a lighter background. A small rectangle in the lower left corner of the display indicates the switch position. A dark rectangle indicates the BLK-HOT switch position; a white rectangle indicates the WHT-HOT switch position.

NOTE

Drive ONLY in the straight-ahead and level 0 degree detent viewing positions.

9. **Azimuth movement** — Full azimuth FIELD OF REGARD (FOR) is achieved by unlocking the Head Mirror and then moving the azimuth control left or right 180 degrees from the straight-ahead position. Releasing the Azimuth Lock control and moving the azimuth to the center position, the Head Mirror will automatically lock into the 0 degree straight-ahead position. Sensor rotates as part of the hatch swivel plate.

10. Elevation movement — The elevation FIELD OF REGARD (FOR) can be changed as much as 10 degrees up from level position by pulling the elevation handle toward you. The handle is located on the right side of the azimuth bracket assembly. A single detent (handle full forward) is provided at level 0 degree position to assist the driver in returning to a normal driving level position.
11. Manual wiper control — Pull down on wiper control to operate wiper and release to return wiper to stow position.

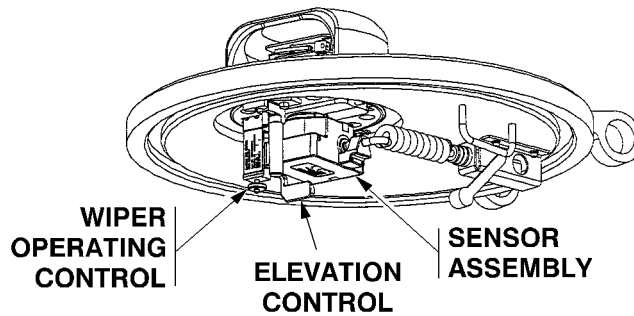
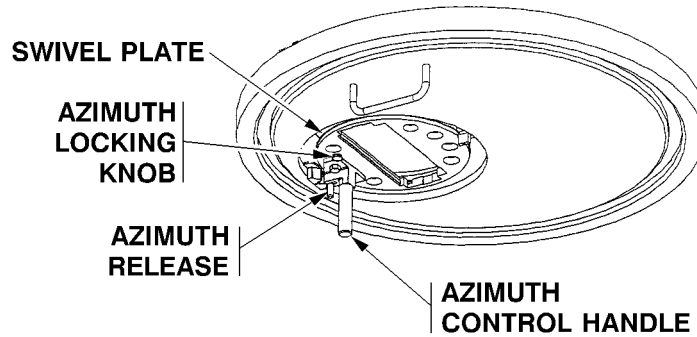

SHUTDOWN

1. Refer to the following steps for shutdown procedures:
 - a. Unstow the driver's display and commander's display as required, by pulling display adjustment knobs out and positioning display in the viewing position.

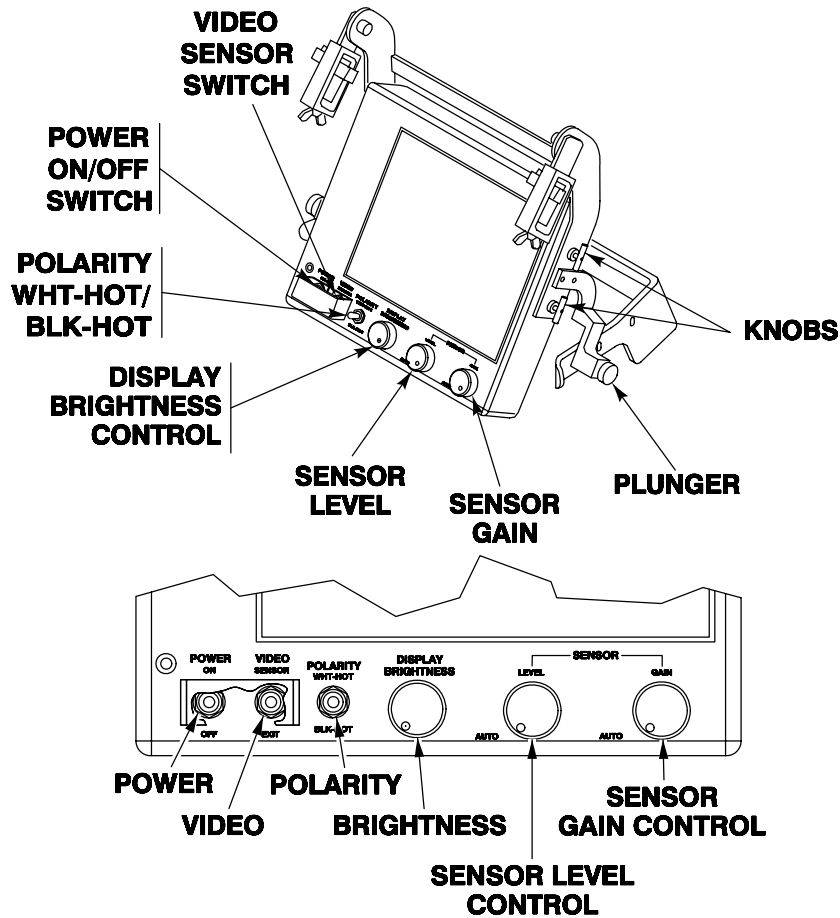

- b. Set SENSOR LEVEL and GAIN controls to full counterclockwise (AUTO) detent position.
- c. With the DISPLAY BRIGHTNESS control turned fully counterclockwise, rotate the knob approximately 1/4 turn clockwise.
- d. Set POLARITY switch to WHT-HOT (up position).
- e. Set VIDEO switch to SENSOR (up position).
- f. Set POWER switch to OFF (down position).

END OF TASK

REPLACE DRIVER'S/COMMANDER'S DISPLAY (DVE) (M58 ONLY)

0035 03

THIS WORK PACKAGE COVERS:

Removal (page 0035 03-1).
 Installation (page 0035 03-6).

INITIAL SETUP:

Maintenance Level

Operator

Personnel Required

Driver/Commander

Equipment Condition

Engine stopped (WP 0024 00)

DVE switch off (WP 0035 02)

Driver's center periscope removed (if removing driver's display) (WP 0033 00)

REMOVAL

NOTE

The DVE in your vehicle may or may not have the commander's display installed. This task covers both configurations.

NOTE

If removing driver's/ commander's display, do Steps 1 - 3.

If removing driver's display, do Steps 4 - 6.

If removing commander's display, do Steps 7 - 10.

1. If commander's display is installed in vehicle, remove connector W3P1 from connector A1J5, connector W2P2 from connector A1J2, and connector 516B P2 from connector A1J1 on driver's display.

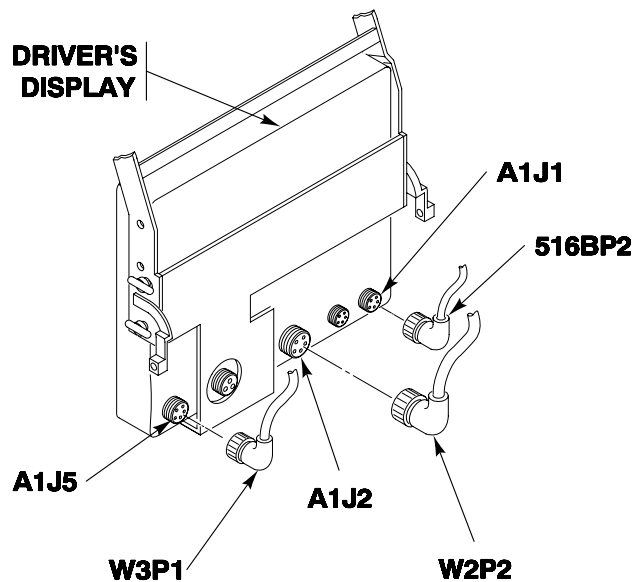

2. Stow cable connectors W3P1, W2P2, and 516B P2 in dummy connectors on the side of the guide.

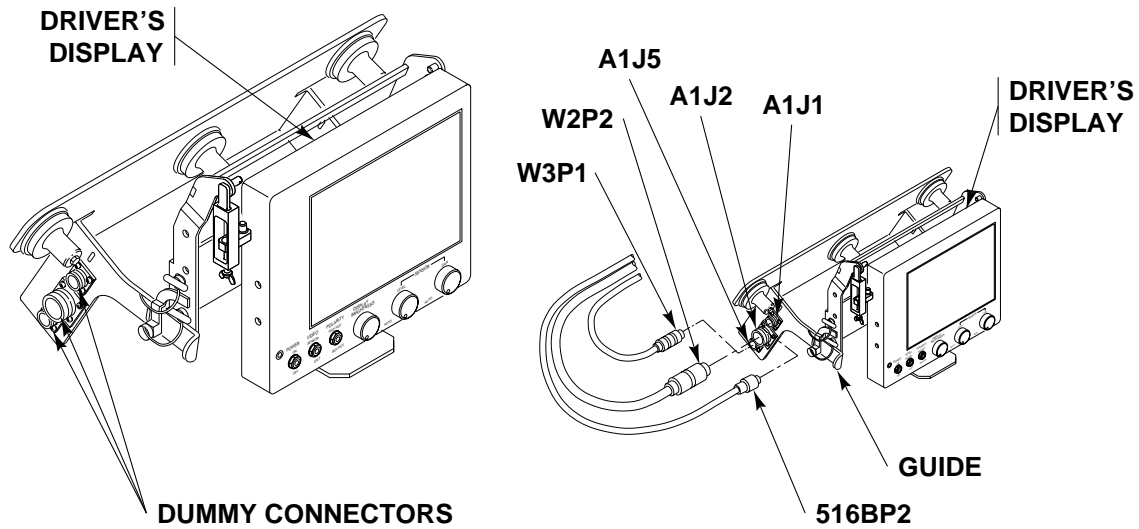

3. While holding driver's display, remove four knobs and driver's display from bracket.

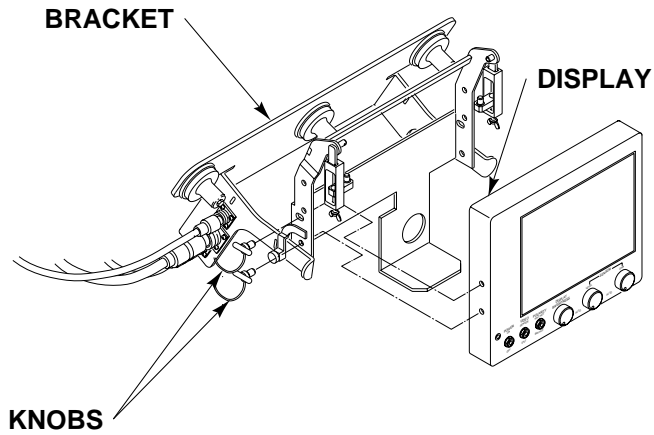

- If commander's display is not installed in vehicle, remove connector W2P2 from connector A1J2 and connector 516B P2 from connector A1J1 on driver's display.

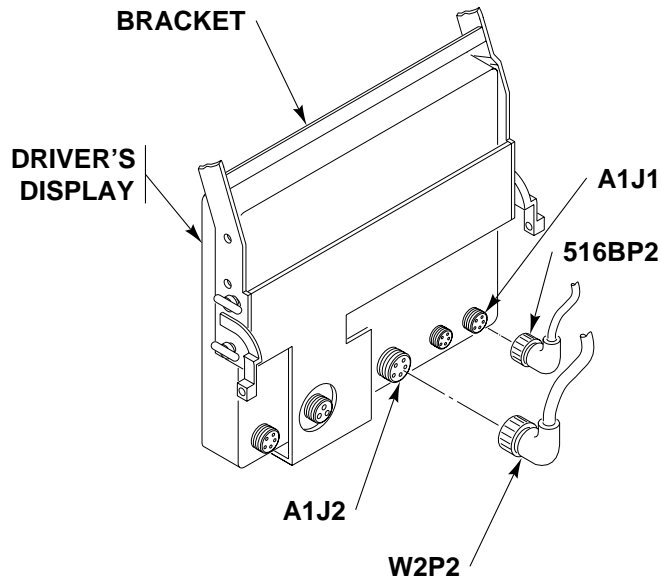

- Stow cable connectors W2P2 and 516B P2 in dummy connectors on the side of the guide.

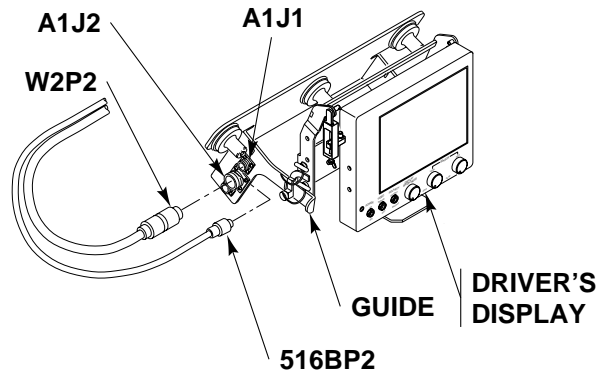

- While holding driver's display, remove four knobs and driver's display from bracket.

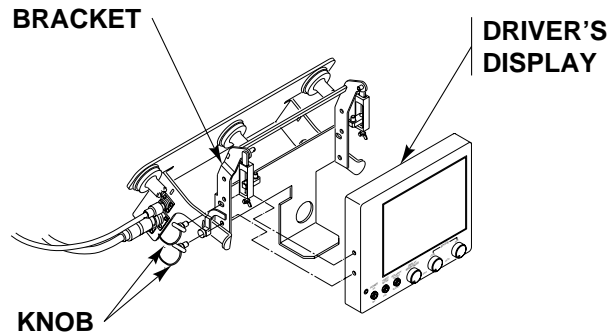

7. Remove connector W3P2 from connector A1J2 and connector W3P3 from connector A1J1 on commander's display.

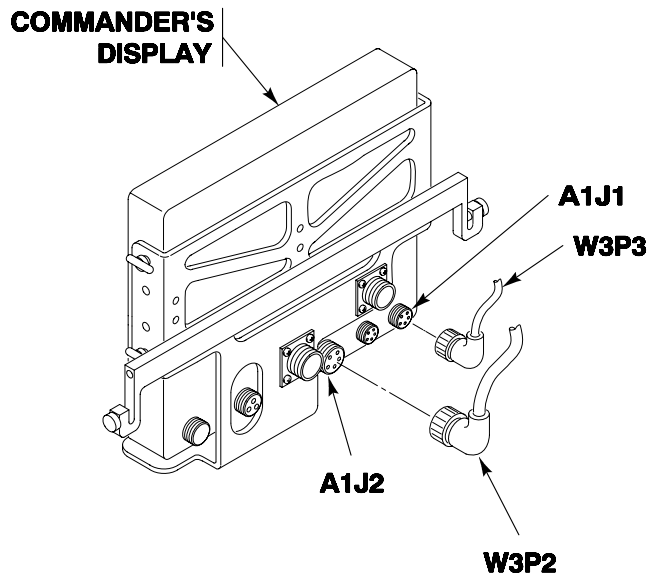

8. Stow cable connectors W3P2 and W3P3 in dummy connectors on the backside of bracket.

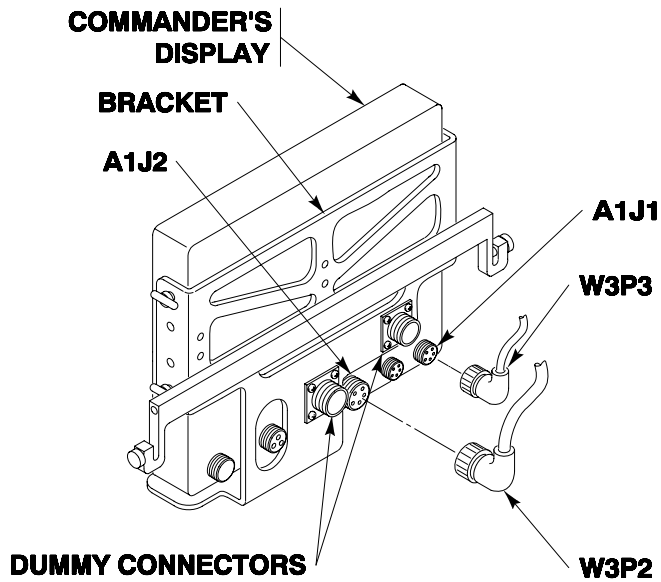

9. Remove two quick release plungers securing bracket to bracket with display and swing commander's display and bracket up to access two lower knobs. Remove two lower knobs securing commander's display to bracket. Swing bracket with commander's display down.

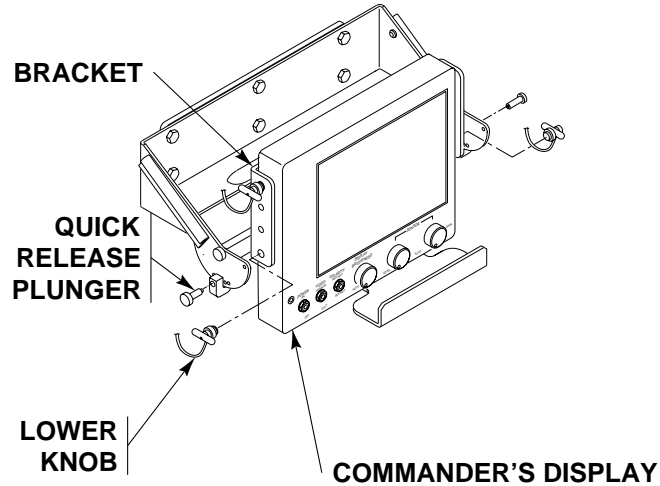

10. While holding commander's display, remove two upper knobs and commander's display from bracket.

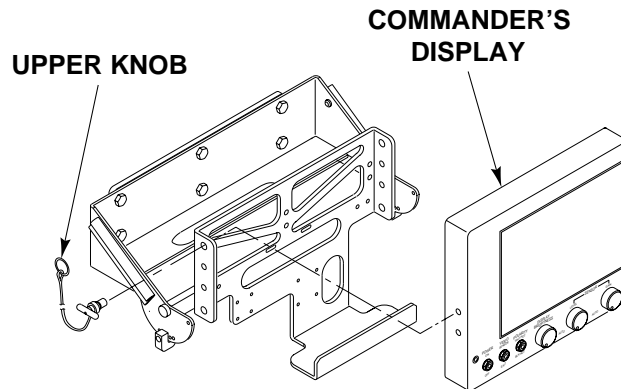

INSTALLATION

NOTE

If installing commander's display, do Steps 1 - 4.

If installing driver's display, do Steps 5 - 6.

If installing driver's/commander's display, do Steps 7 - 8.

1. Position commander's display on bracket. Swing commander's display and bracket up and install two lower knobs securing commander's display to bracket.

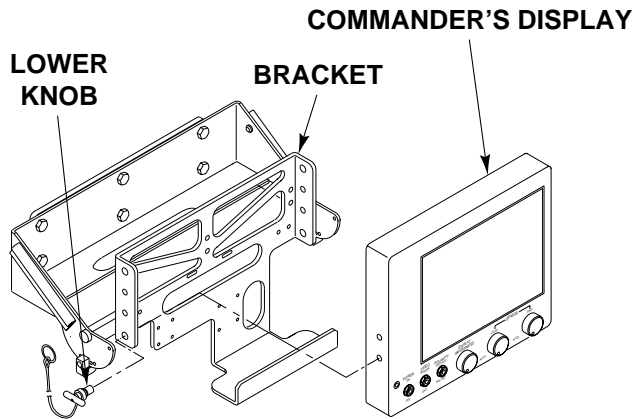

2. Lower commander's display and bracket and install two upper knobs securing commander's display to bracket.

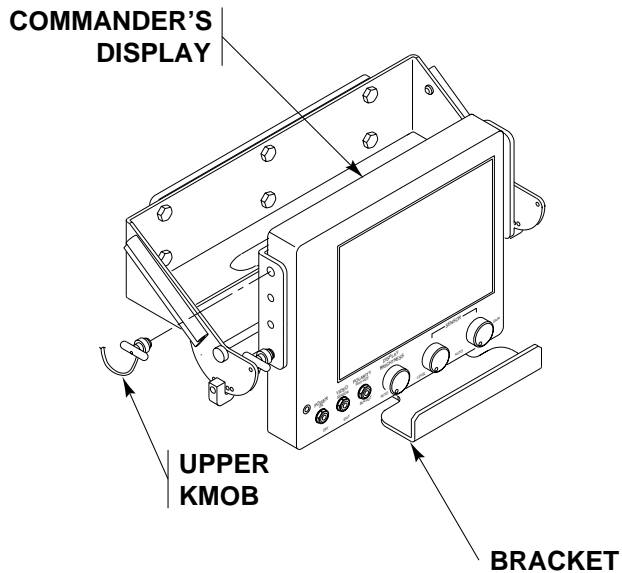

3. Install two quick release plungers securing bracket to bracket with commander's display.

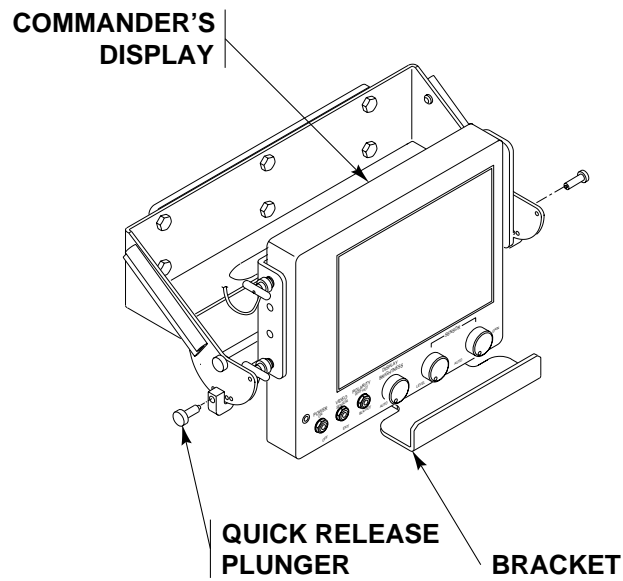

4. Remove connector W3P2 and connector W3P3 from dummy connectors on the backside of bracket and install connector W3P2 to connector A1J2 and connector W3P3 to connector A1J1 on commander's display.

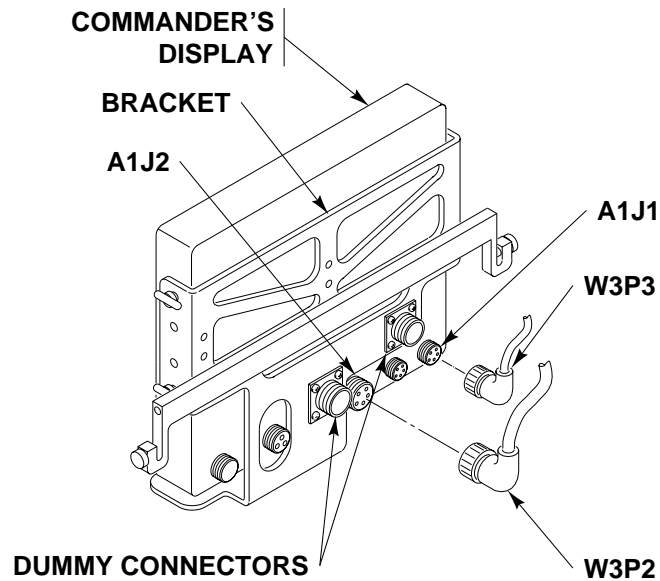

5. Position driver's display on bracket and secure with four knobs.

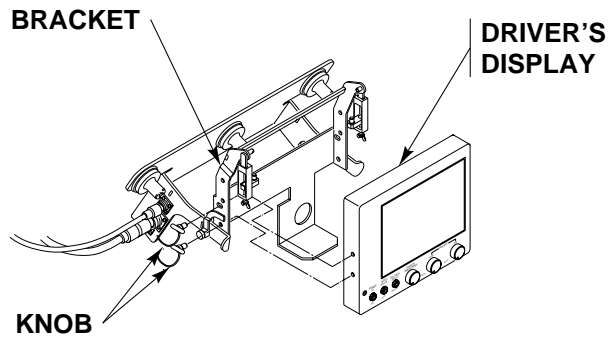

6. If commander's display is not installed in vehicle, remove connectors W2P2 and 516B P2 in dummy connectors on the side of the guide and install connector W2P2 to connector A1J2 and connector 516B P2 to connector A1J1 on driver's display.

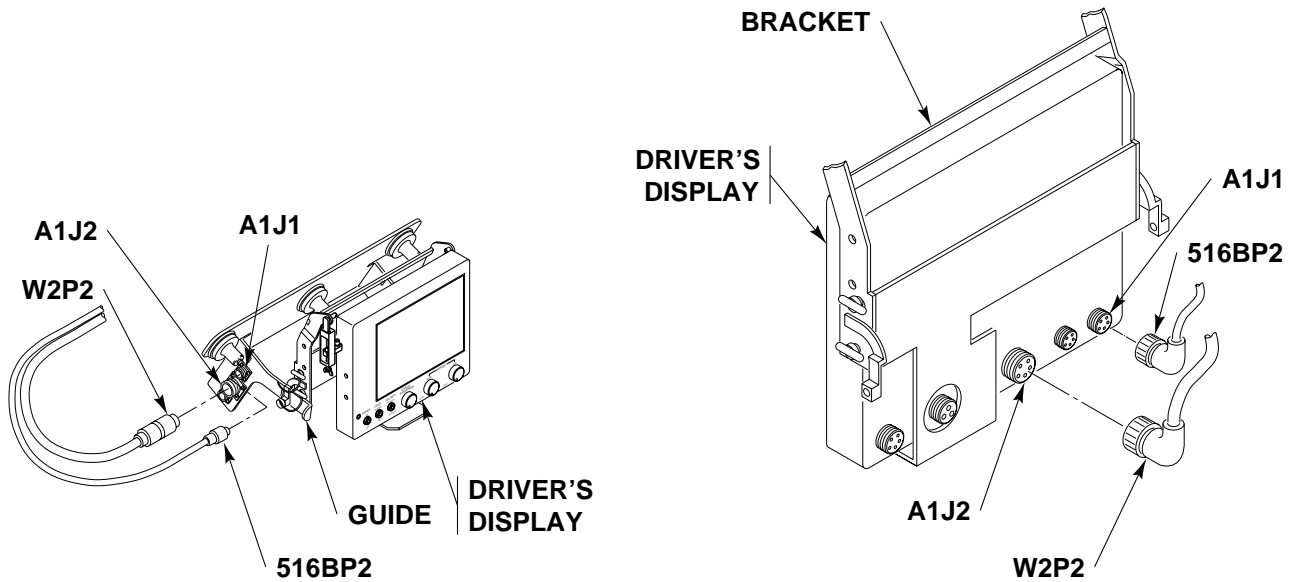

7. Position driver's display on bracket and secure with four knobs.

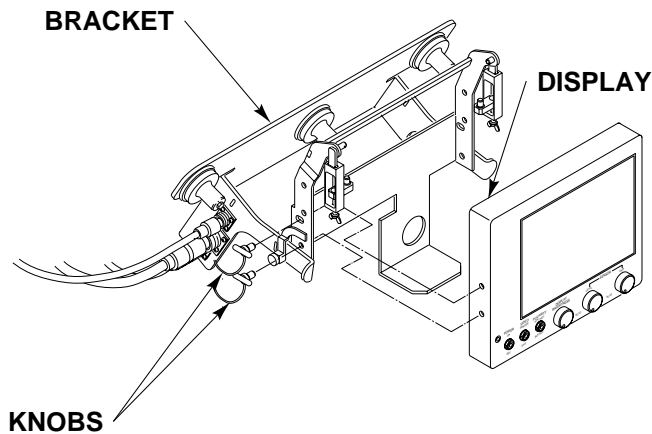

8. If commander's display is installed in vehicle, remove connectors W2P1, W2P2, and 516B P2 in dummy connectors on the side of the guide and install connector W3P1 to connector A1J5, connector W2P2 to connector A1J2, and connector 516B P2 to connector A1J1 on driver's display.

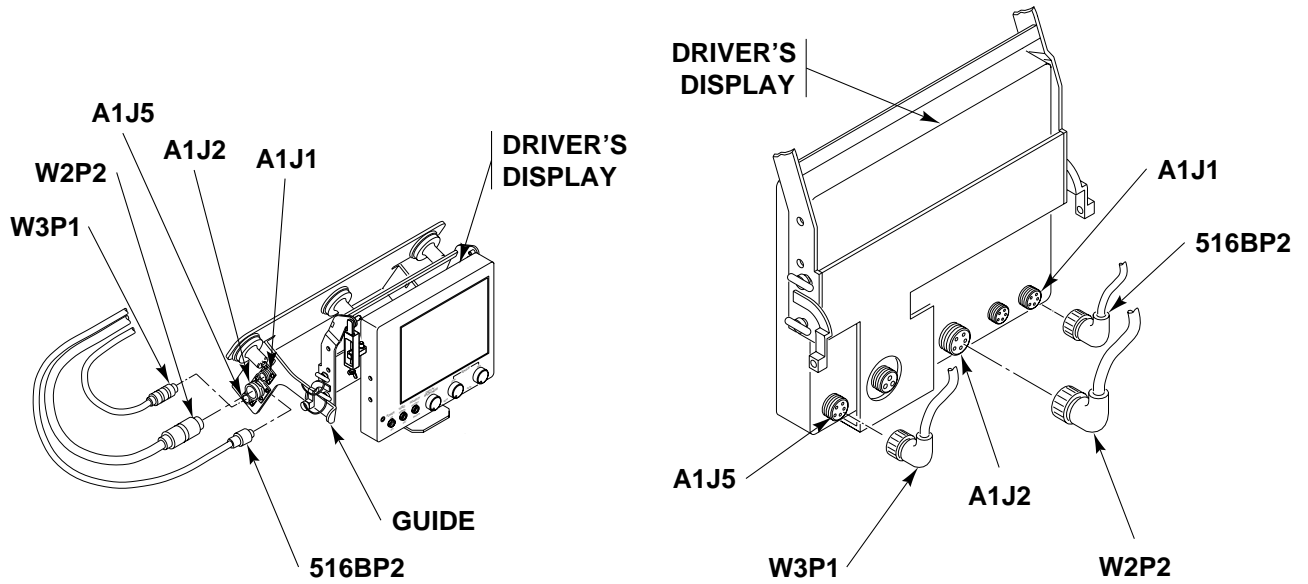

FOLLOW-THROUGH STEPS

1. Install driver's center periscope, if removed (WP 0033 00).

END OF TASK

INSTALL/REMOVE MACHINE GUN (M2, .50 CAL) (M113A3, M1059A3, M1064A3, AND M58 ONLY)

0036 00

THIS WORK PACKAGE COVERS:

- Install Machine Gun (page 0036 00-1).
- Remove Machine Gun (page 0036 00-3).

INITIAL SETUP:

Maintenance Level

Operator

Personnel Required

Soldier

Equipment Condition

Engine stopped (WP 0024 00)

Commander's cupola locked at desired position (WP 0010 00)

INSTALL

NOTE

On some carriers the traverse travel lock is an arm on left side of machine gun mount. On other carriers the traverse travel lock is a hinged lug on right side of machine gun pintle. Both are shown. If your carrier is equipped with traverse travel lock arm, go to Step 1. If it is equipped with traverse travel lock lug, go to Step 2.

1. Remove pin from commander's cupola mount to release traverse travel lock arm.

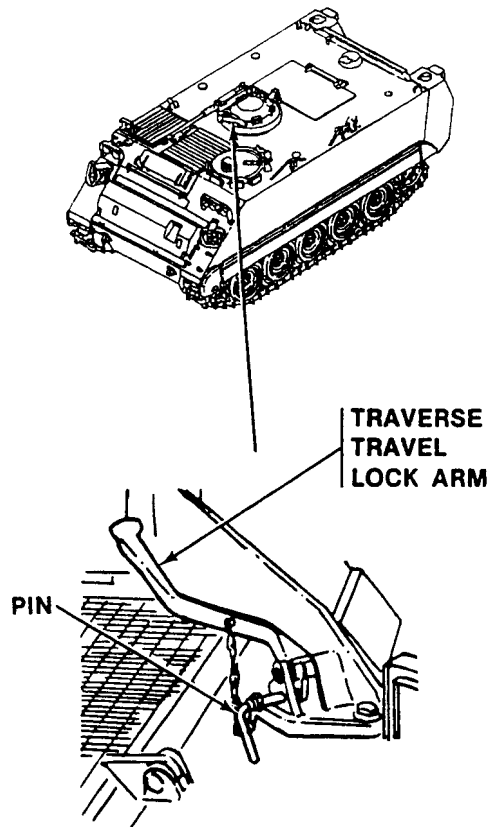

WITH TRAVERSE TRAVEL LOCK ARM:

- Remove pin from commander's cupola mount to release traverse travel lock lug.

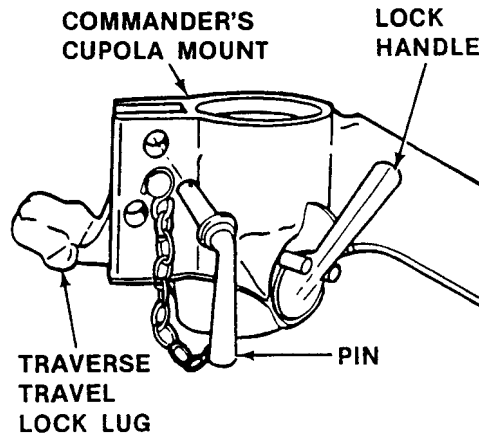

- Push lock handle down and install machine gun pintle in commander's cupola mount.

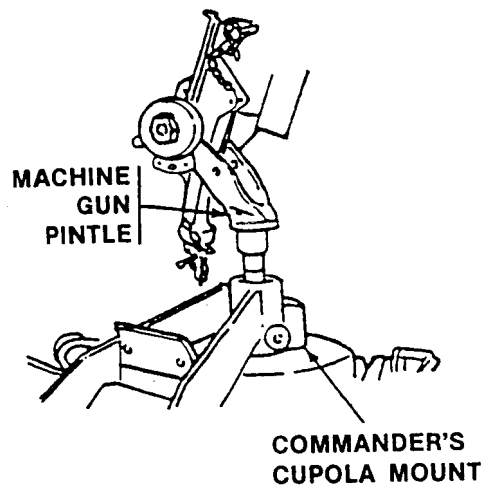

NOTE

If lock handle did not come up when you installed machine gun pintle in Step 3 above, push lock handle up.

- Install ammunition tray on T bar.

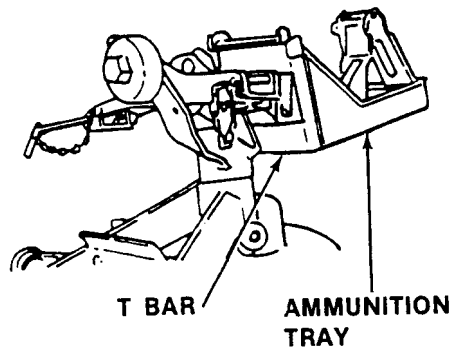

INSTALL/REMOVE MACHINE GUN (M2, .50 CAL) (M113A3, M1059A3, M1064A3, AND M58 ONLY) — Continued

0036 00

5. Remove cradle pins from machine gun pintle.
6. Align front and rear holes in machine gun with holes in cradle and install cradle pins.

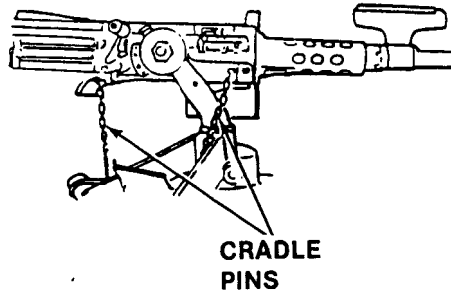

REMOVE

1. Remove cradle pins and lift machine gun out of pintle.

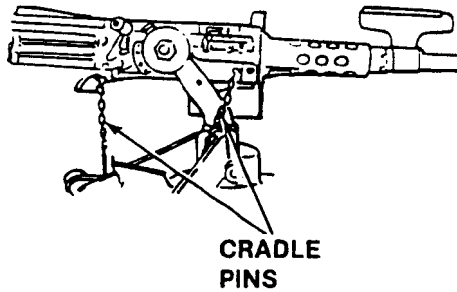

2. Remove ammunition tray from T bar.

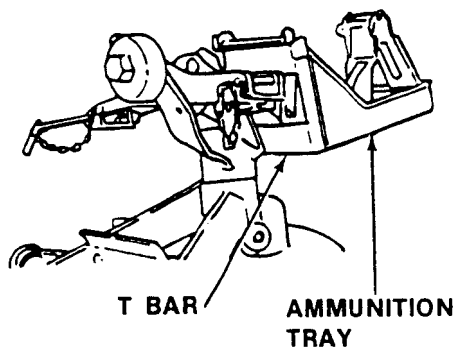

INSTALL/REMOVE MACHINE GUN (M2, .50 CAL) (M113A3, M1059A3, M1064A3, AND M58 ONLY) — Continued

0036 00

3. Push lock handle down and remove machine gun pintle from commander's cupola mount.

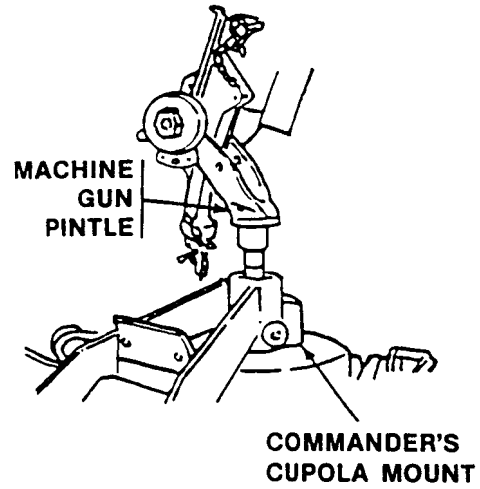
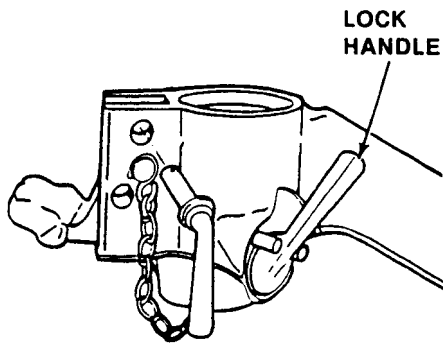

END OF TASK

SECURE MACHINE GUN (M2, .50 CAL) FOR TRAVEL (M113A3, M1059A3, M1064A3, AND M58 ONLY)

0037 00

THIS WORK PACKAGE COVERS:

Secure Machine Gun (page 0037 00-1).

INITIAL SETUP:

Maintenance Level

Operator

Equipment Condition

Machine gun installed (WP 0036 00)

Personnel Required

Soldier

SECURE MACHINE GUN

NOTE

On some carriers the traverse travel lock is an arm on left side of machine gun mount. On other carriers the traverse travel lock is a hinged lug on right side of machine gun pintle. Both are shown.

1. Install travel lock pin in machine gun pintle.

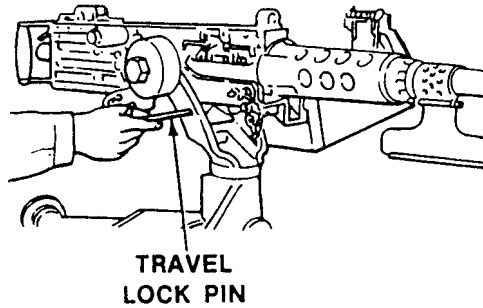

NOTE

If carrier is equipped with traverse travel lock lug, go to Step 2. If carrier is equipped with traverse travel lock arm, go to Step 3.

2. Install traverse travel lock pin in machine gun mount.

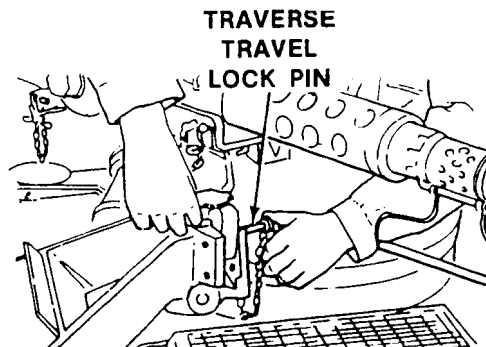

**SECURE MACHINE GUN (M2, .50 CAL) FOR TRAVEL (M113A3, M1059A3, M1064A3,
AND M58 ONLY) — Continued**

0037 00

3. Install traverse travel lock pin in machine gun mount.

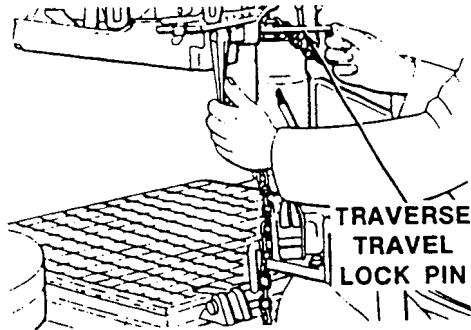

END OF TASK

**SECURE MACHINE GUN (M2, .50 CAL) TO ARMOR SHIELD FOR TRAVEL
(M113A3, M1059A3, AND M1064A3 ONLY)**

0038 00

THIS WORK PACKAGE COVERS:

Secure Machine Gun (page 0038 00-1).

INITIAL SETUP:

Maintenance Level

Operator

Equipment Condition

Machine gun installed (WP 0036 00)

Personnel Required

Soldier

SECURE MACHINE GUN

1. Loosen travel strap and remove clamp from cupola opening.
2. Install clamp on machine gun lower bracket.
3. Tighten travel strap.

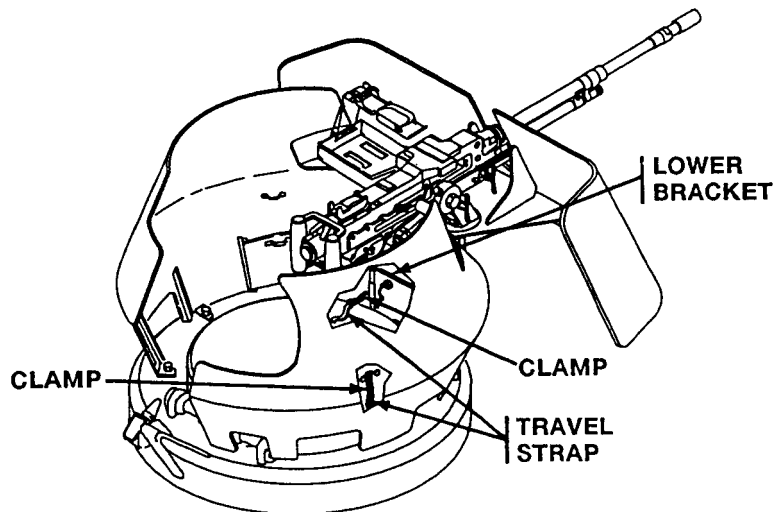

END OF TASK

LOWER/STOW TRIM VANE

0039 00

THIS WORK PACKAGE COVERS:

Lower (page 0039 00-1).
 Stow (page 0039 00-2).

INITIAL SETUP:

Maintenance Level

Operator

Equipment Condition

Carrier stopped

Personnel Required

Soldier (2)

WARNING



Trim vane is heavy. Personnel can be injured and equipment damaged. Have helper assist. Open and lower trim vane slowly. Avoid being caught between trim vane and hull or ground.

LOWER

1. Pull trim vane quick release handle to disengage quick release from extension linkage.

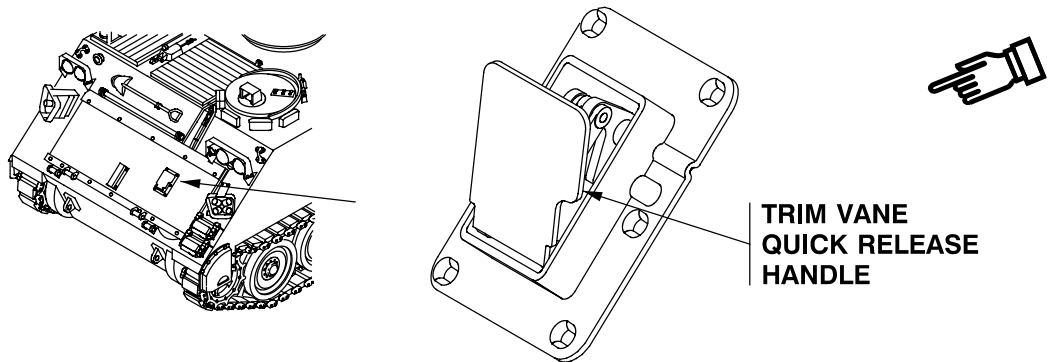

2. Lower trim vane.

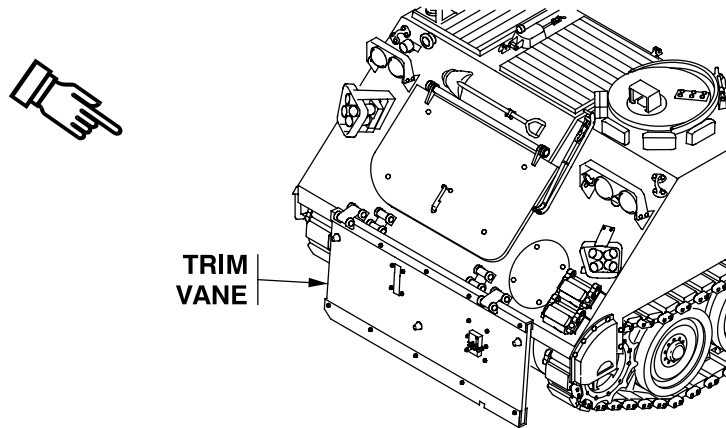
**STOW**

1. Raise and hold trim vane in stowed position.
2. Pull trim vane quick release handle. Aline quick release with extension linkage.
3. Release quick release handle to secure trim vane in stowed position.

END OF TASK

REMOVE/INSTALL POWER PLANT ACCESS PANELS

0040 00

THIS WORK PACKAGE COVERS:

Remove Power Plant Access Panels (page 0040 00-2).
Install Power Plant Access Panels (page 0040 00-4).

INITIAL SETUP:

Maintenance Level

Operator

Equipment Condition

Engine stopped (WP 0024 00)

Personnel Required

Driver

NOTE

Driver's power plant access panel and rear power plant access panels are removed and installed the same way.

REMOVE

1. Loosen t-bolts and clamps securing power plant access panels to bulkhead.

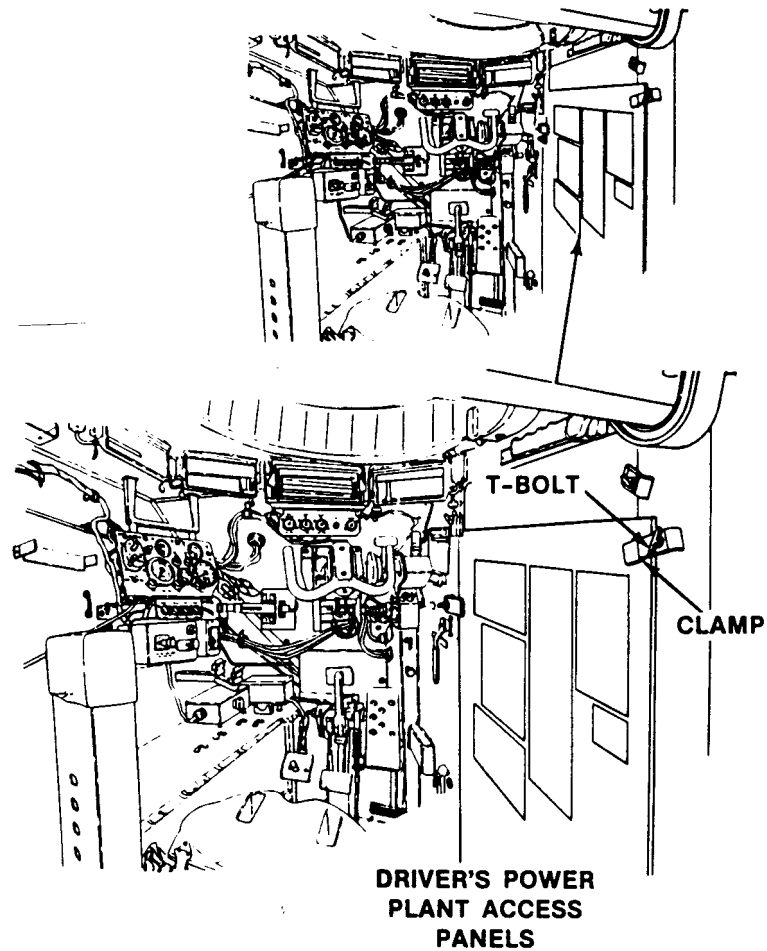

2. Remove power plant access panels from bulkhead supports.

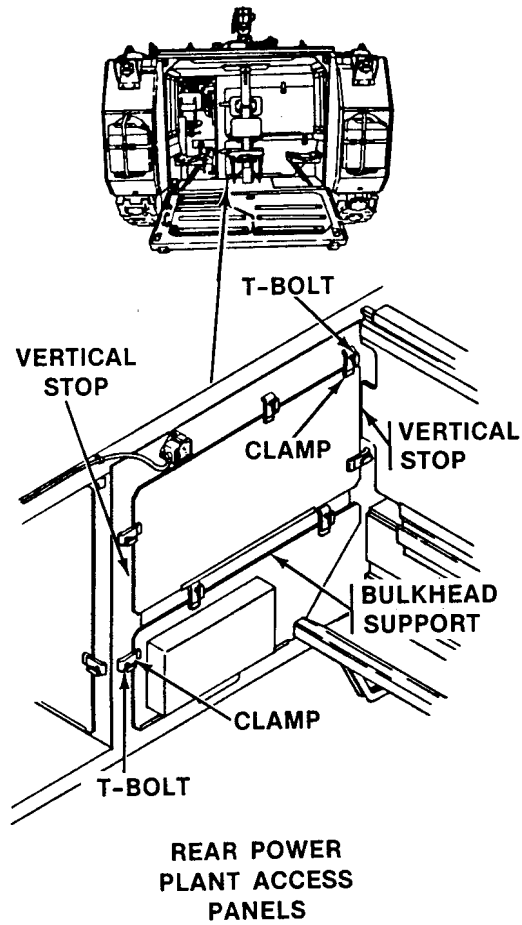

INSTALL

1. Place power plant access panels in bulkhead supports and center between vertical stops.
2. Position clamps over power plant access panels and tighten t-bolts.

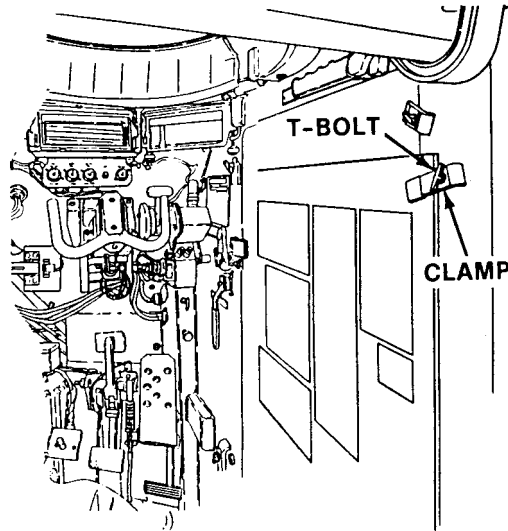
**END OF TASK**

POSITIONING SPALL LINERS FOR ACCESS TO EQUIPMENT (M113A3 ONLY)

0041 00

THIS WORK PACKAGE COVERS:

Positioning spall liners for access to equipment (page 0041 00-1).

INITIAL SETUP:

Maintenance Level

Operator

Equipment Condition

Carrier stopped

Spall liners secured in fully closed position

Personnel Required

Soldier

POSITIONING SPALL LINERS FOR ACCESS TO EQUIPMENT

NOTE

Four right side spall liners and four left side spall liners open and close the same way.

1. Remove three pins securing spall liners in closed position.
2. Slide spall liners to the front or rear as needed to gain access to equipment.

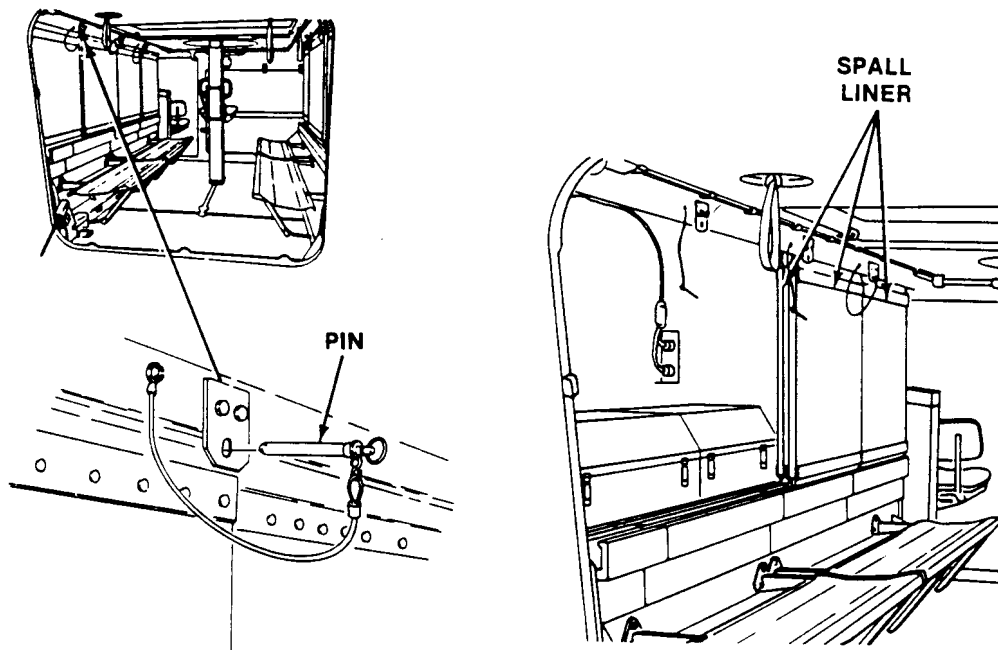

POSITIONING SPALL LINERS FOR ACCESS TO EQUIPMENT (M113A3 ONLY) —
Continued

0041 00

3. Reposition spall liners to fully closed position and align mounting holes in spall liners with mounting holes in brackets.
4. Install three pins to secure spall liners in place.

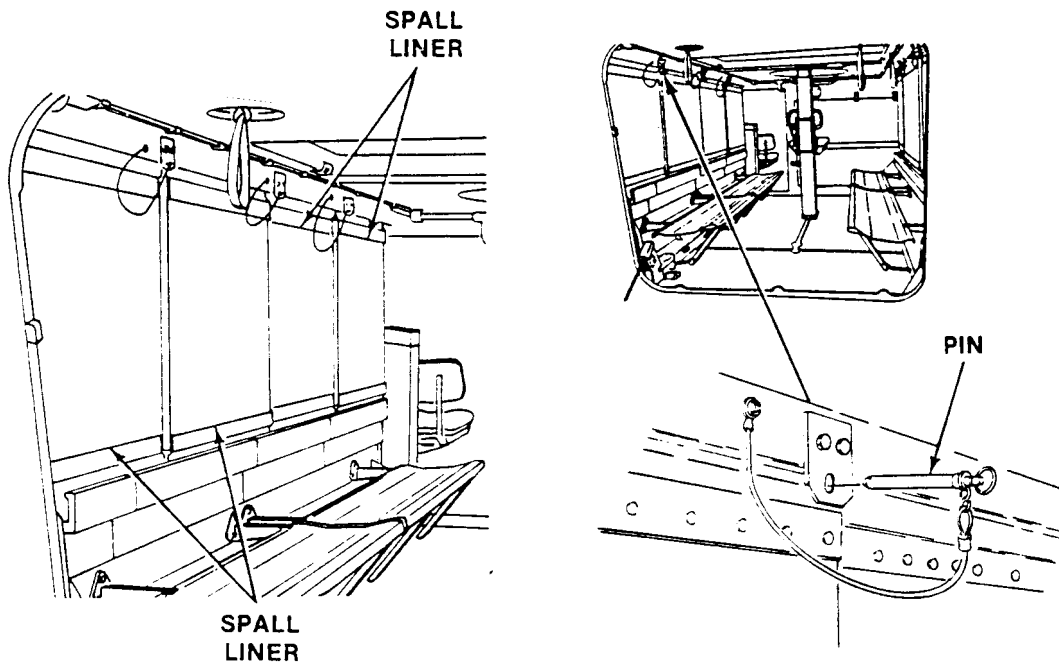
**END OF TASK**

BLOCK/UNBLOCK CARRIER TRACKS

0042 00

THIS WORK PACKAGE COVERS:

Block carrier tracks (page 0042 00-1).
 Unblock carrier tracks (page 0042 00-1).

INITIAL SETUP:

Maintenance Level

Operator

Equipment Condition

Carrier stopped

Personnel Required

Driver

BLOCK

1. Place a block of wood or other suitable object between track guides and two sets of road wheels. Make sure object extends full width between road wheels.

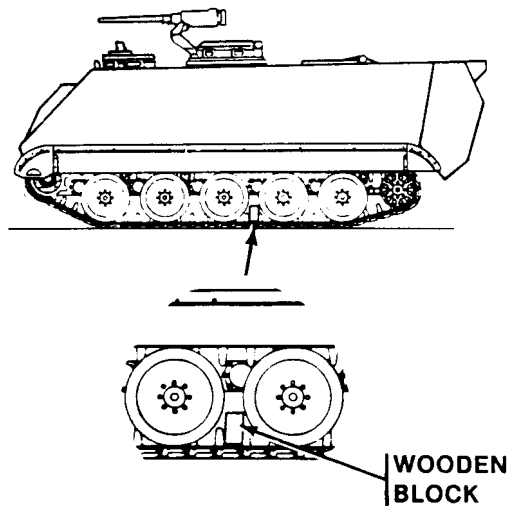

UNBLOCK

1. Remove block of wood or other object from between track guides and road wheels.

END OF TASK

INSTALL/REMOVE WATER/RATION HEATER

0043 00

THIS WORK PACKAGE COVERS:

Install water/ration heater (page 0043 00-1).
 Remove water/ration heater (page 0043 00-2).

INITIAL SETUP:

Maintenance Level

Operator

Equipment Condition

Carrier stopped

Personnel Required

Driver

INSTALL WATER/RATION HEATER

1. Locate heater mounting bracket on right rear crew compartment bulkhead.

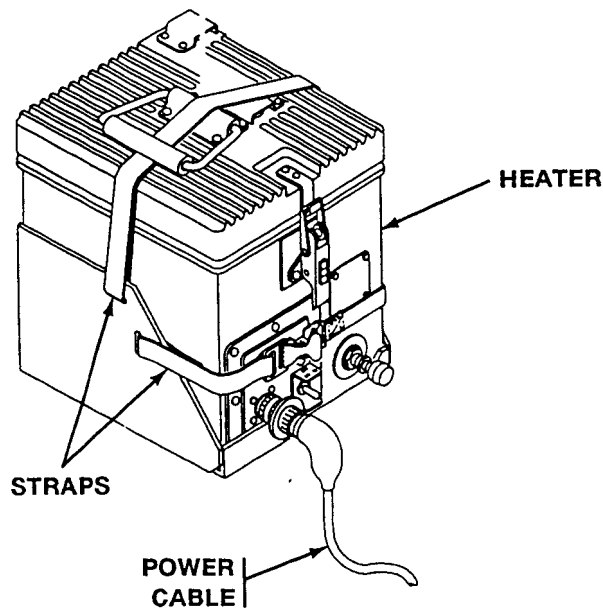

2. Place heater on bracket and secure with two straps, as shown.
3. Connect accessory power cable to receptacle on heater.

REMOVE WATER/RATION HEATER

1. Remove accessory power cable from receptacle on heater.

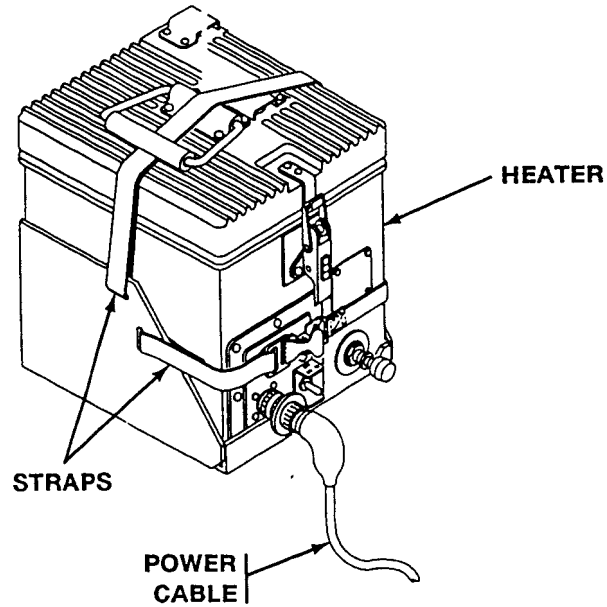

2. Remove two straps securing heater to heater mounting bracket.
3. Remove heater from mounting bracket.

END OF TASK

OPERATE WATER/RATION HEATER

0044 00

THIS WORK PACKAGE COVERS:

INITIAL SETUP:

Maintenance Level

Operator

References

TM 10-7310-241-12&P

Personnel Required

Driver

Equipment Condition

MASTER SWITCH ON (WP 0004 00)

1. For troubleshooting, operation, maintenance, and repair parts see TM 10-7310-241-12&P.

END OF TASK

OPERATE 5.0 KW AUXILIARY POWER UNIT (APU) (M577A3 AND M1068A3 ONLY)

0045 00

THIS WORK PACKAGE COVERS:

Operate (page 0045 00-1).

INITIAL SETUP:

Maintenance Level

Operator

Personnel Required

Driver

Crew

References

TM 9-6115-664-13&P

WP 0095 00

Equipment Condition

Carrier stopped

Engine stopped (WP 0024 00)

OPERATE

1. Turn carrier MASTER SWITCH to ON.
2. Start and operate the APU, as described in TM 9-6115-664-13&P.
3. Shut down APU, as described in TM 9-6115-664-13&P.
4. Turn carrier MASTER SWITCH to OFF.
5. Check batteries (WP 0095 00).

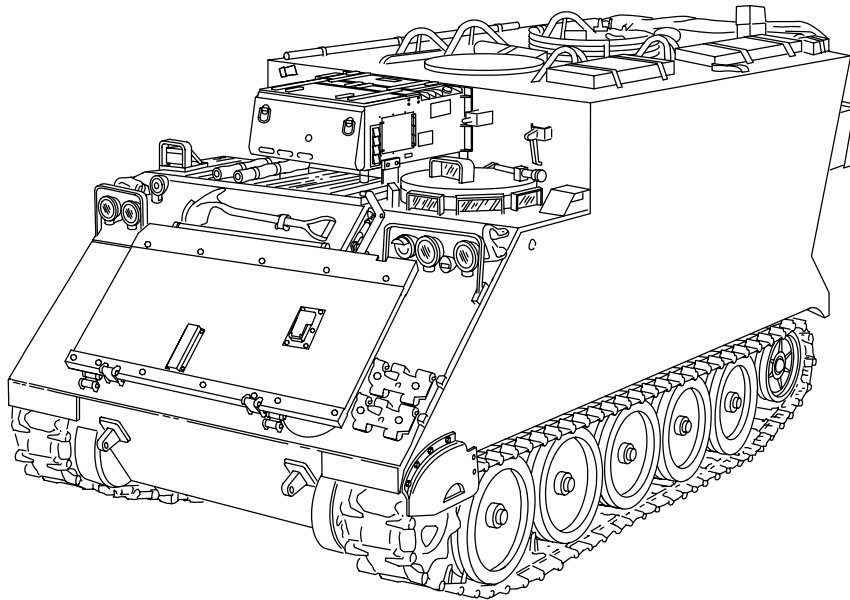

END OF TASK

OPEN/CLOSE COMMANDER'S HATCH (M577A3 AND M1068A3 ONLY)

0046 00

THIS WORK PACKAGE COVERS:

- Open (page 0046 00-1).
- Close (page 0046 00-2).

INITIAL SETUP:

Maintenance Level

Operator

Equipment Condition

Carrier stopped

Personnel Required

Soldier

OPEN

WARNING

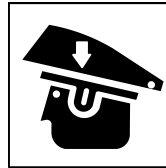

Unsecured hatch cover could move and hit you in the head. When hatch is open, secure latch with locking pin.

1. From inside carrier, press latch to release spring and open hatch cover.
2. Push hatch cover all the way back. Make sure it is secured by hold-open latch.
3. Remove locking pin from block. Secure hatch with locking pin.

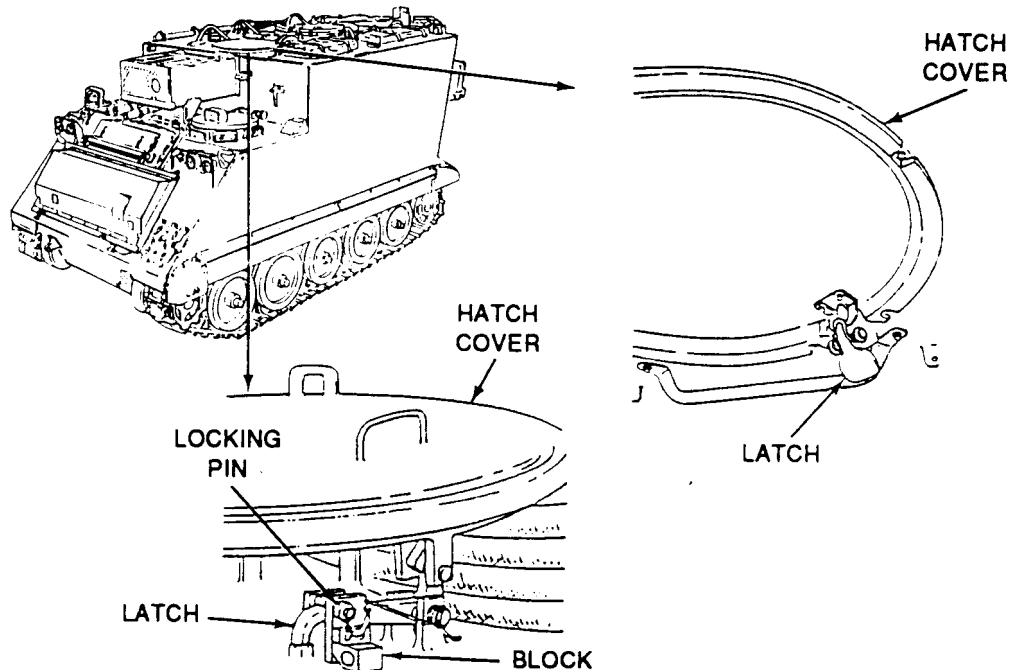

CLOSE HATCH

1. Remove latch locking pin and stow pin in block.
2. Lift latch to release cover and close hatch.

END OF TASK

OPERATE COMMANDER'S PLATFORM (M577A3 AND M1068A3 ONLY)

0047 00

THIS WORK PACKAGE COVERS:

- Adjust (page 0047 00-1).
- Stow (page 0047 00-2).
- Lower (page 0047 00-2).

INITIAL SETUP:

Maintenance Level

Operator

Equipment Condition

Carrier stopped

Personnel Required

Soldier

ADJUST PLATFORM

1. Move handle towards post to disengage pin from hole in post. Release handle when platform is at desired height. The securing catch will hold platform in position.

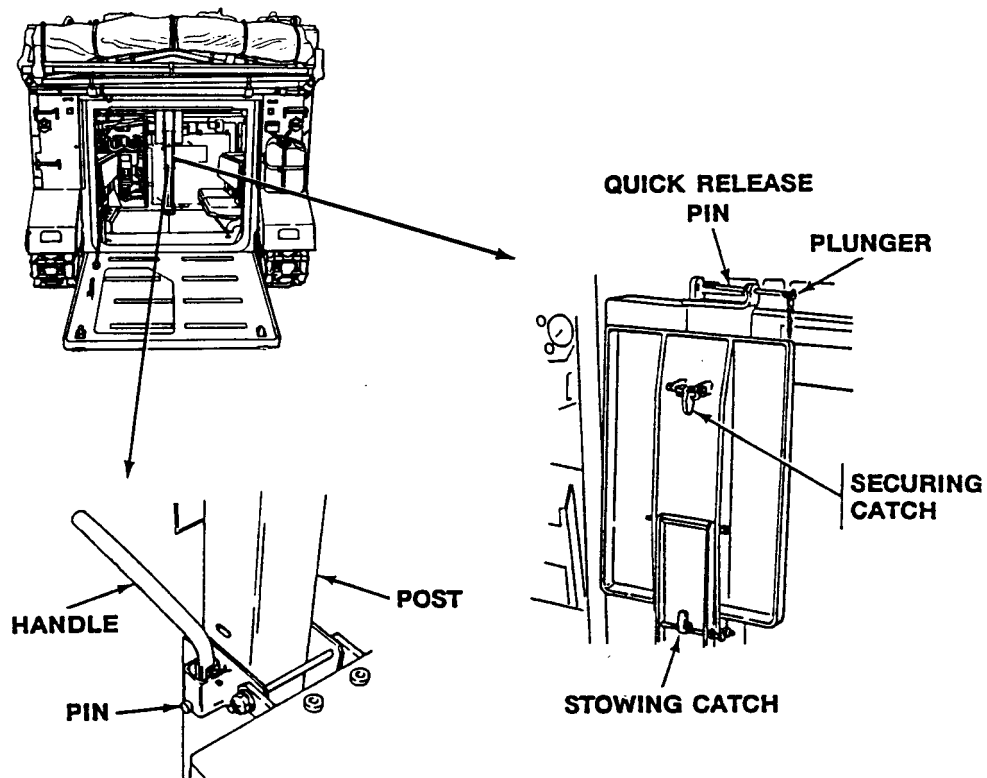

STOW PLATFORM

1. Fold platform against post. The stowing catch will secure platform against post.

LOWER PLATFORM

1. Depress plunger in pin and remove pin. Lower platform to floor.

END OF TASK

OPEN/CLOSE DRIVER'S HATCH (M577A3 AND M1068A3 ONLY)

0048 00

THIS WORK PACKAGE COVERS:

Open (page 0048 00-1).
Close (page 0048 00-3).

INITIAL SETUP:

Maintenance Level

Operator

Equipment Condition

Carrier stopped

Personnel Required

Driver

OPEN HATCH

WARNING

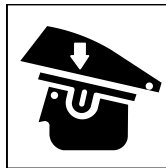

Unsecured hatch cover could move and hit you in the head. When hatch is open, secure hatch with locking pin.

NOTE

Exterior latch is spring loaded.

1. OPEN HATCH.

- a. From inside carrier, lift latch and push hatch cover back until bracket on cover is secured by hook.
- b. Remove latch locking pin from block and install locking pin in bracket to secure hook.

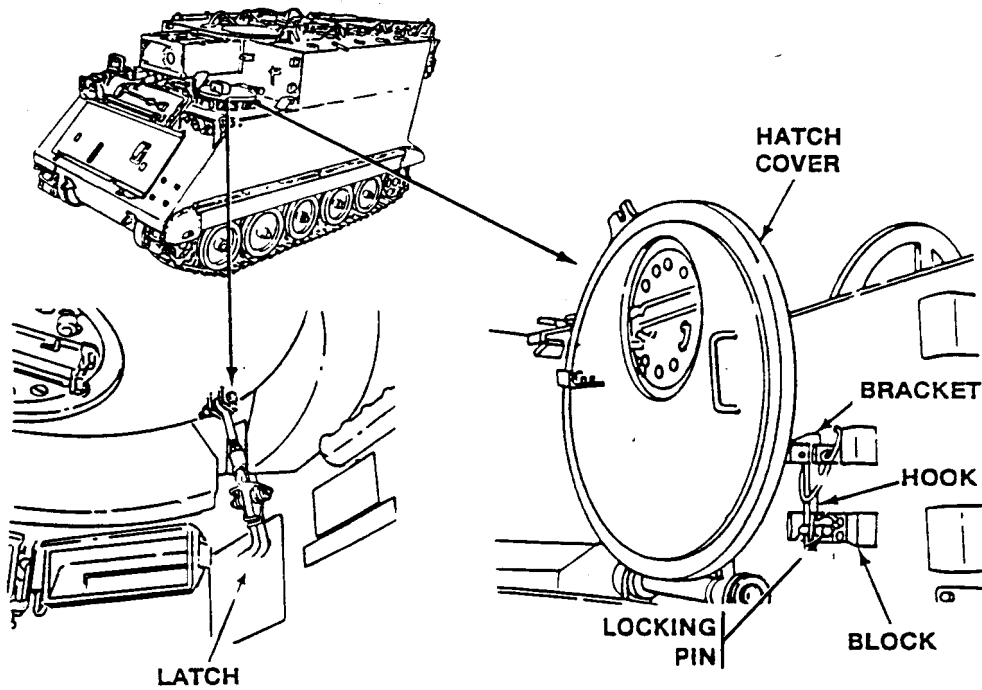

CLOSE HATCH

WARNING

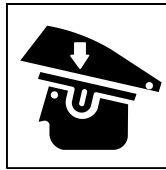

Unsecured hatch cover could move and hit you in the head. When hatch is closed, secure hatch with exterior locknut.

1. CLOSE HATCH.
 - a. Remove latch locking pin and stow in block.
 - b. Pull latch to release hatch cover.

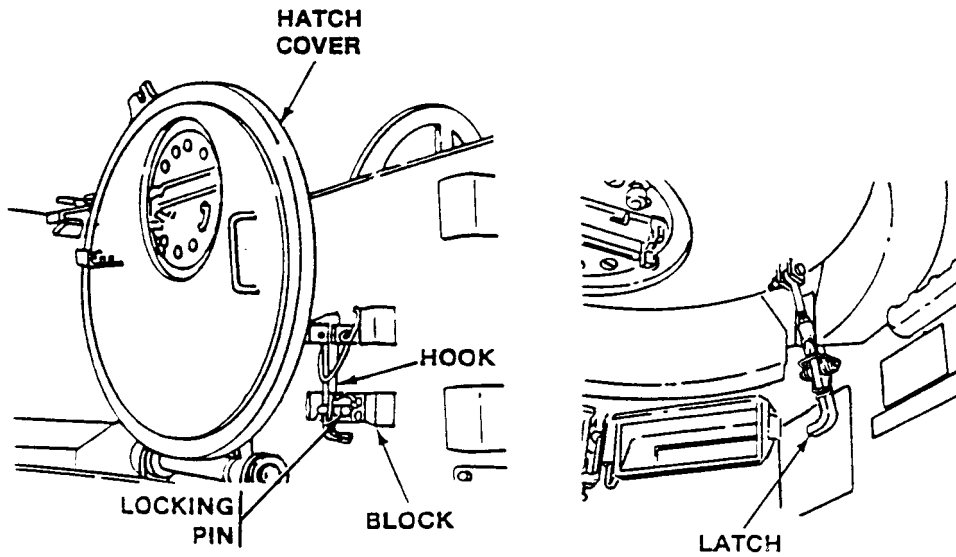

- c. Secure hatch cover closed with exterior locknut.

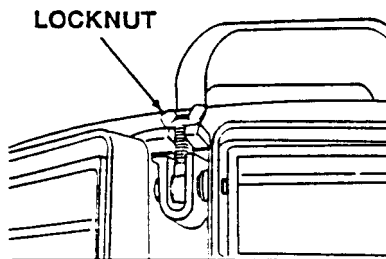

END OF TASK

RAISE/LOWER DROP LEAF TABLES (M577A3 ONLY)

0049 00

THIS WORK PACKAGE COVERS:

- Raise (page 0049 00-1).
- Lower (page 0049 00-1).

INITIAL SETUP:

Maintenance Level

Operator

Equipment Condition

Carrier stopped

Personnel Required

Driver

RAISE TABLES

NOTE

The section of table over the battery box is raised to provide access to the battery box.

1. RAISE TABLES.

- a. Raise tables and secure by turning supports 90 degrees from the stowed position. Support should rest against catch.

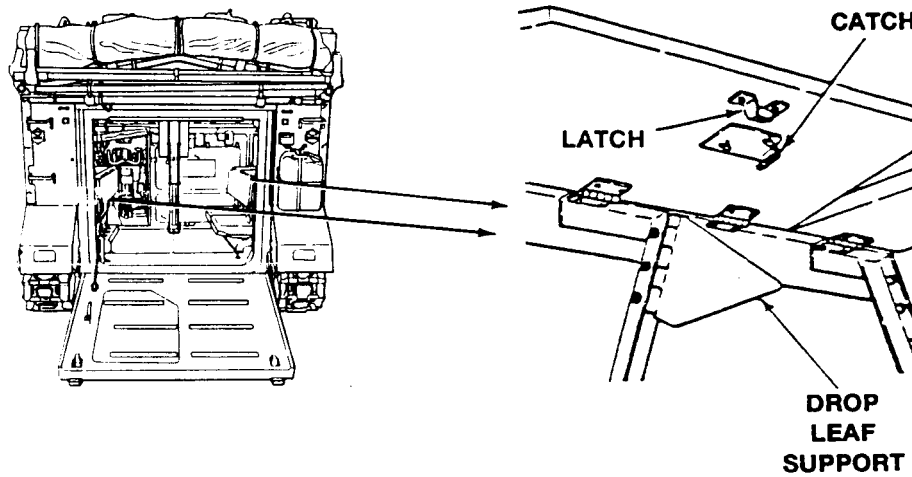

LOWER TABLES

1. LOWER TABLES.

- a. Rotate supports 90 degrees towards stowed position, and lower tables.

END OF TASK

INSTALL/REMOVE DRIVER'S BLACKOUT CURTAIN (M577A3 AND M1068A3 ONLY)

0050 00

THIS WORK PACKAGE COVERS:

Install (page 0050 00-1).
Remove (page 0050 00-2).

INITIAL SETUP:

Maintenance Level

Operator

Equipment Condition

Carrier stopped

Personnel Required

Crew

INSTALL CURTAIN

1. INSTALL CURTAIN.

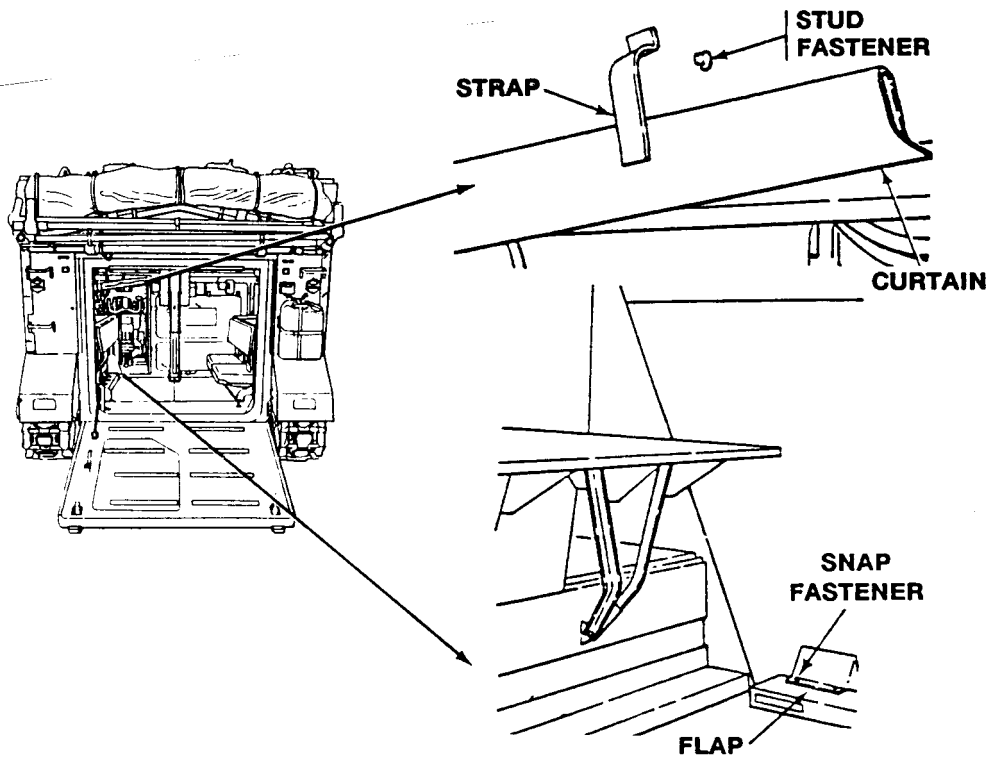

- a. Unsnap straps from stud fasteners above entrance to driver's compartment.
- b. Let curtain fall to bottom of opening. Secure with snap fasteners on heater duct.

INSTALL/REMOVE DRIVER'S BLACKOUT CURTAIN (M577A3 AND M1068A3 ONLY) —
Continued

0050 00

REMOVE CURTAIN

1. REMOVE CURTAIN.
 - a. Unsnap fasteners on heater duct.
 - b. Fold curtain up and snap straps to stud fasteners above entrance to driver's compartment.

END OF TASK

UNSTOW/STOW MAP TABLE AND BOARD (M577A3 AND M1068A3 ONLY)

0051 00

THIS WORK PACKAGE COVERS:

- Unstow map table (M577A3) (page 0051 00-1).
- Unstow map board (M577A3) (page 0051 00-2).
- Stow map table (M577A3) (page 0051 00-3).
- Stow map board (M577A3) (page 0051 00-3).
- Unstow map board (M1068A3) (page 0051 00-4).
- Stow map board (M1068A3) (page 0051 00-4).

INITIAL SETUP:

Maintenance Level

Operator

Equipment Condition

Carrier stopped

Personnel Required

Crew

UNSTOW MAP TABLE (M577A3 ONLY)

1. UNSTOW MAP TABLE.
 - a. Remove straps securing personnel seat to map table.
 - b. Open drop leaf supports on map table. Lock table in position directly below map board on right wall.

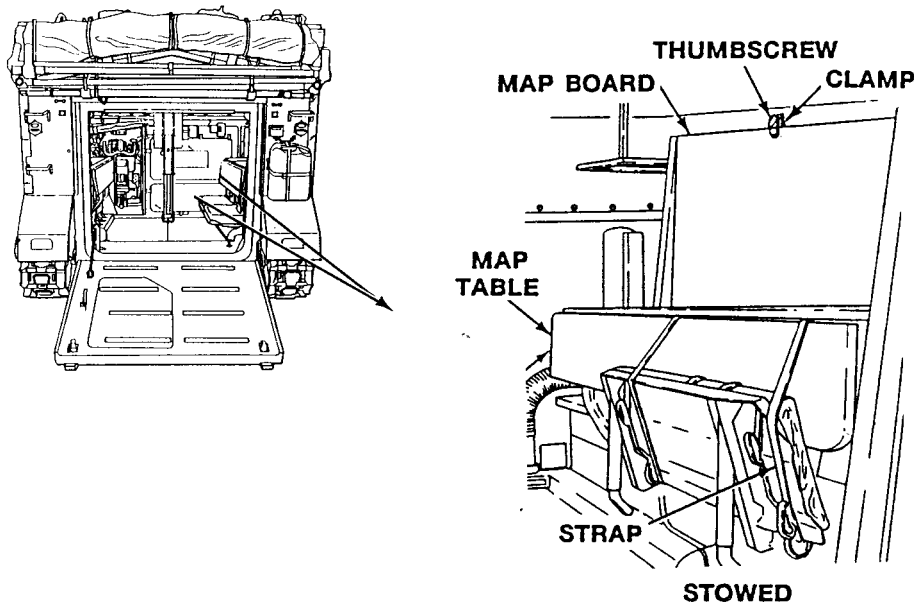

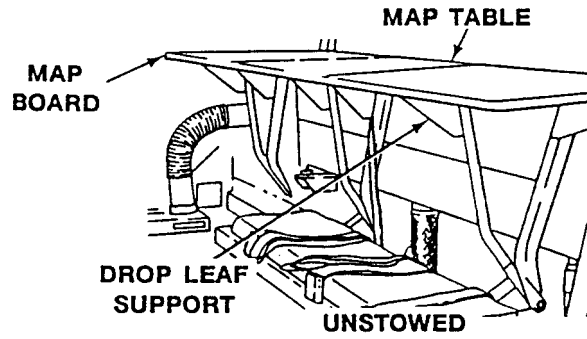

UNSTOW MAP BOARD (M577A3 ONLY)

NOTE

Map board can be removed and used in tent. Chains on back make it easy to hang.

1. LOOSEN THUMBSCREWS, RELEASE CLAMPS, AND LOWER MAP BOARD.

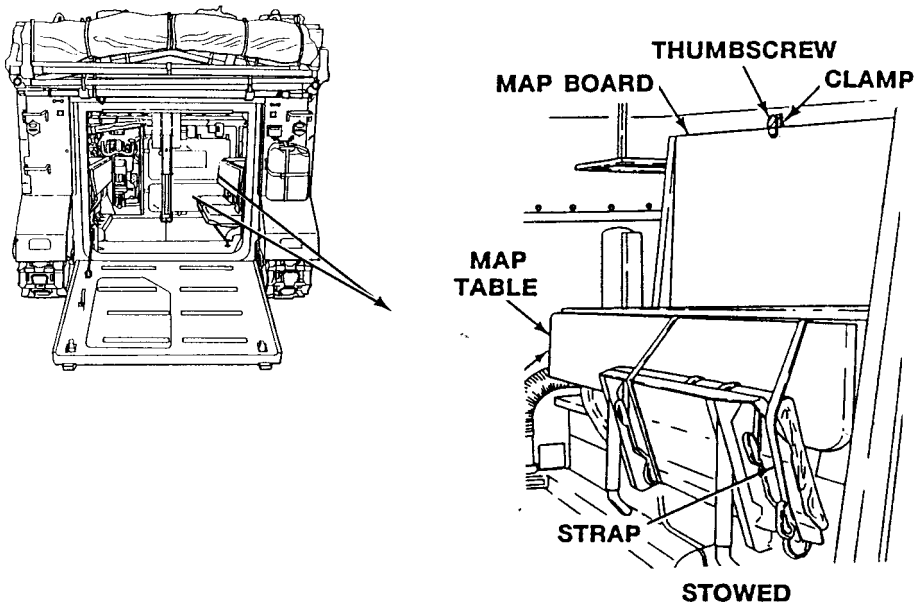

STOW MAP TABLE (M577A3 ONLY)

1. STOW MAP TABLE.
 - a. Close drop leaf supports on map table.
 - b. Install straps to secure personnel seat to map table.

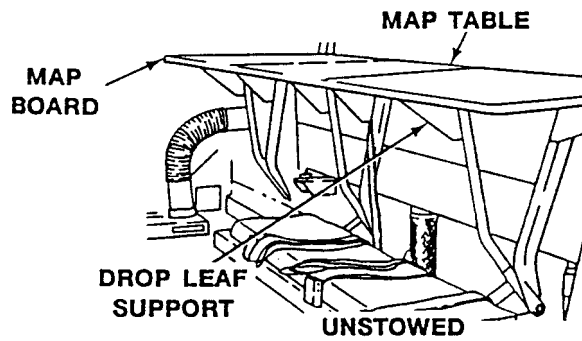

STOW MAP BOARD (M577A3 ONLY)

1. STOW MAP BOARD.
 - a. Raise map board to stowed position.
 - b. Tighten thumbscrews on clamps to secure map board.

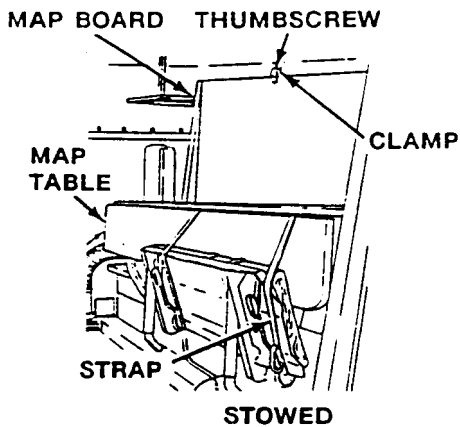

UNSTOW MAP BOARD (M1068A3 ONLY)

1. UNSTOW MAP BOARD.
 - a. Remove strap from two footman loops securing map board.
 - b. Raise two stakes and swing bottom end of map board out.
 - c. Slide two stakes down until they secure map board in desired position.

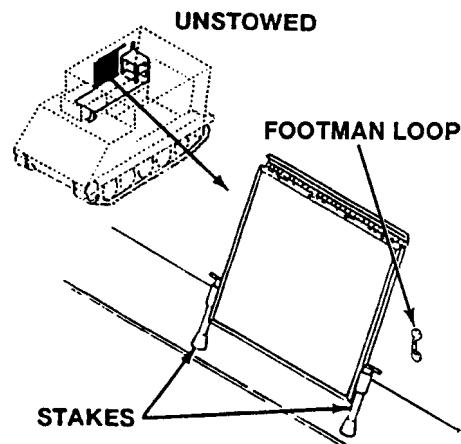
**STOW MAP BOARD (M1068A3 ONLY)**

1. STOW MAP BOARD.
 - a. Pull bottom end of map board up and slide two stakes up.
 - b. Swing map board against hull and slide two stakes down to secure in stowed position.
 - c. Install strap through footman loops to secure map board.

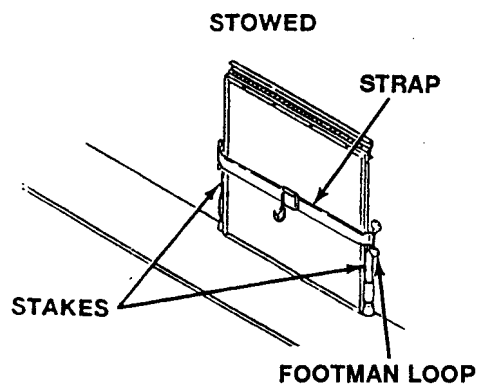
**END OF TASK**

OPEN/CLOSE MORTAR HATCH COVER (M1064A3 ONLY)

0052 00

THIS WORK PACKAGE COVERS:

- Open (page 0052 00-1).
- Close (page 0052 00-2).

INITIAL SETUP:

Maintenance Level

Operator

Equipment Condition

Engine stopped (WP 0024 00)

Personnel Required

Crewmember

OPEN

1. Position commander's cupola sideways so the machine gun does not interfere with hatch cover opening.
2. Pull chains to release the inside door catches. Push hatch upward with free hand to open.

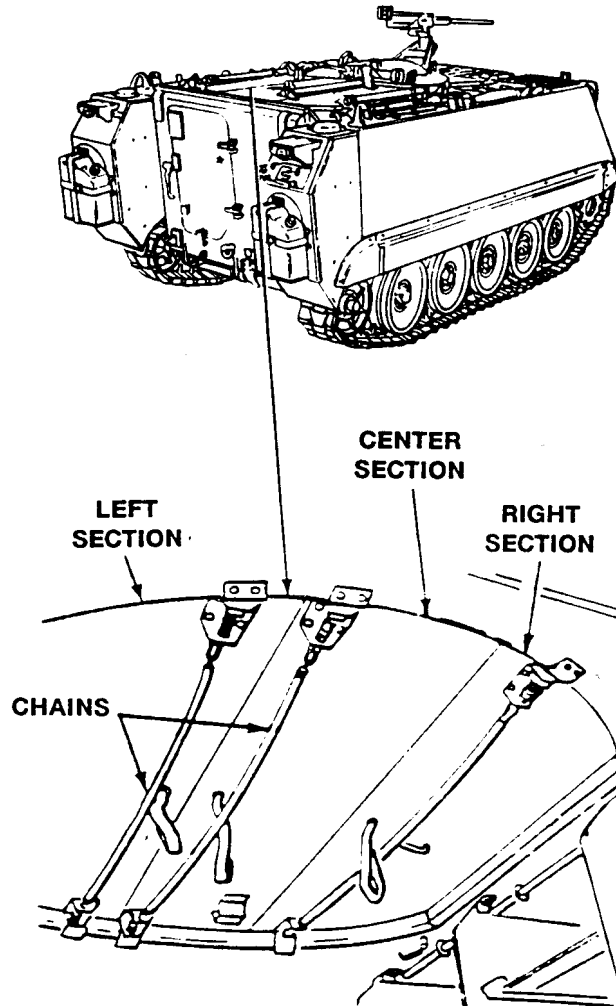

3. Fold center section back on the right section until it locks. Then push both sections back on the top deck.
4. Push left section and fold back on the top deck.
5. Make sure the hatch sections are locked in the spring loaded catches on the top deck. One catch secures center section to right section.

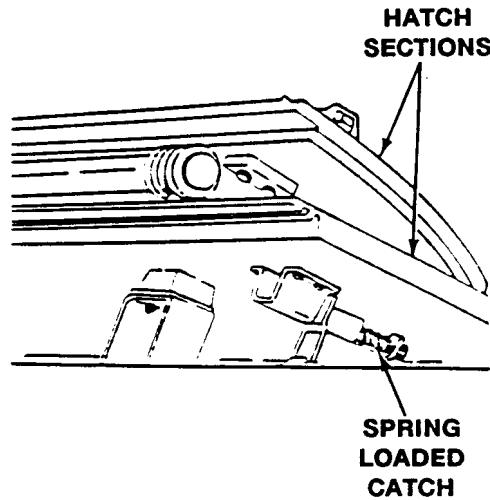

CLOSE

1. Turn outside catch handle to release catch holding right section to top deck.

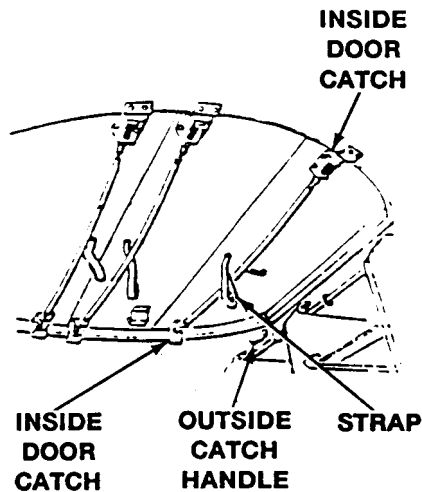

NOTE

Use hatch straps to pull down hatches. Use chains to lock.

2. Pull on strap to close right section of hatch and engage the inside door catches.

3. Turn outside catch handle to release catch holding left section to top deck.

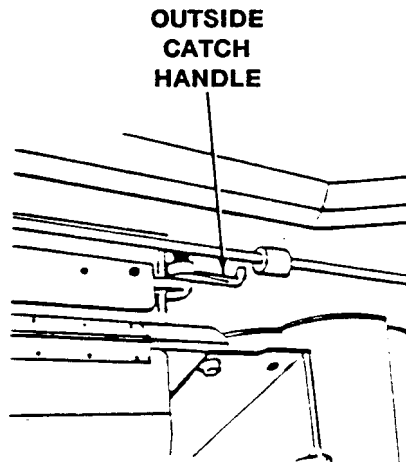

4. Pull on strap to close left section and engage inside door latches.

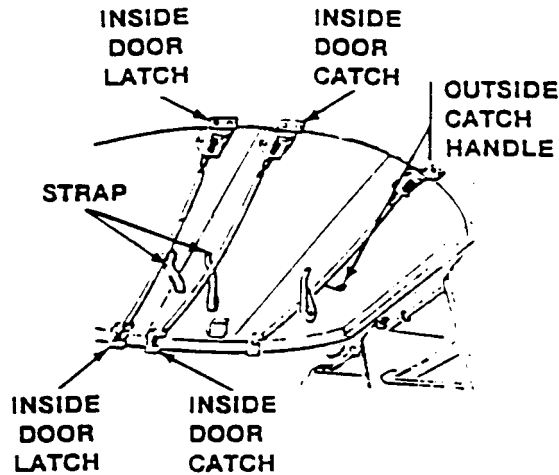

5. Turn outside catch handle to release catch holding center section of hatch to right section.
6. Pull strap to close center section and engage inside door catches.

END OF TASK

REMOVE/INSTALL 4.2 KW GENERATOR SET (M577A3 AND M1068A3 ONLY)

0054 00

THIS WORK PACKAGE COVERS:

Removal (page 0054 00-1).
 Installation (page 0054 00-3).

INITIAL SETUP:

Maintenance Level

Operator

Equipment Condition

Carrier stopped

Personnel Required

Driver
 Crew

REMOVE

1. Remove waterproof cover if auxiliary unit is to be removed from enclosure.
2. Loosen thumbscrews and clamps securing generator set to enclosure. Turn clamps 90 degrees.

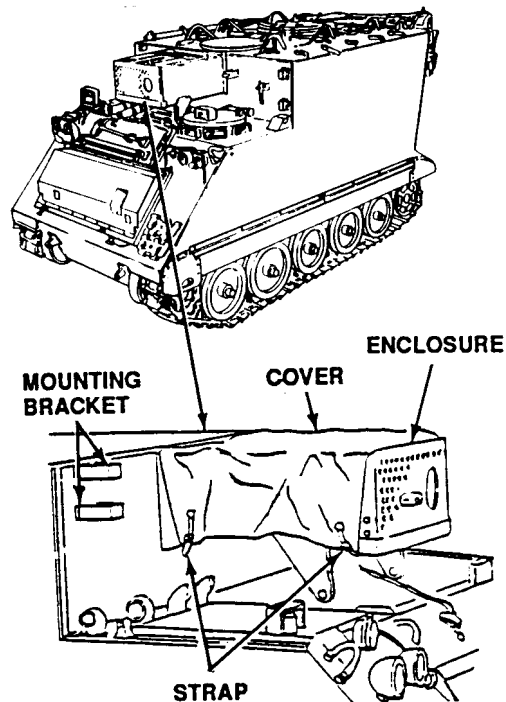

Continued

3. Remove davit from stowed position on top deck. Remove chain hoist from stowed position on sponson.

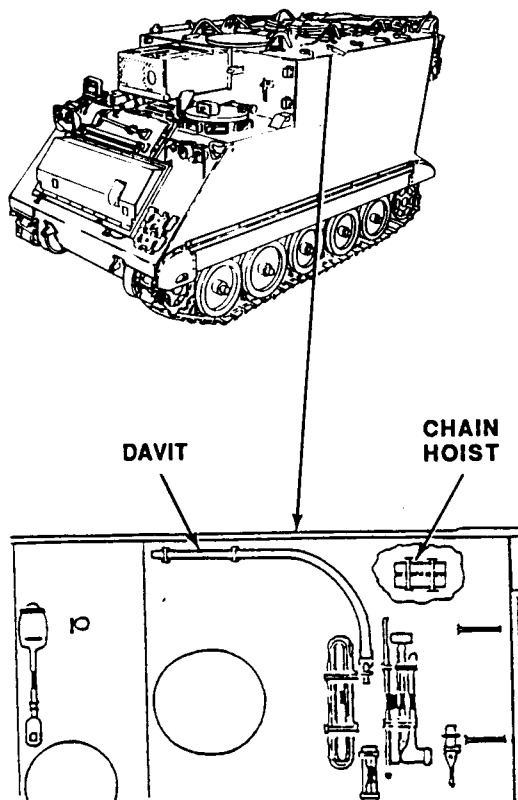

4. Position davit in mounting brackets. Attach chain hoist hooks to davit and lifting bar on generator set.

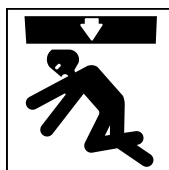
WARNING

Hanging loads, heavy parts, and overhead equipment can fall unexpectedly and kill or injure you.

Stay clear of hanging loads, heavy parts, and overhead equipment. Use correct lifting devices. Always have helper guide heavy parts and equipment.

5. Hoist generator set enough to clear enclosure. Swing generator set clear of carrier and lower it to the ground.

REMOVE/INSTALL 4.2 KW GENERATOR SET (M577A3 AND M1068A3 ONLY) —
Continued

0054 00

6. Stow davit and chain hoist on top deck.

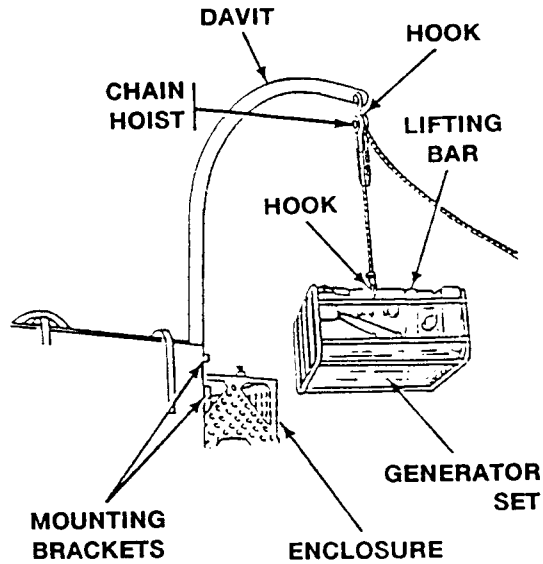

INSTALL

1. Remove davit from stowed position on top deck of carrier. Remove chain hoist from bag on inside of carrier, right side sponson.

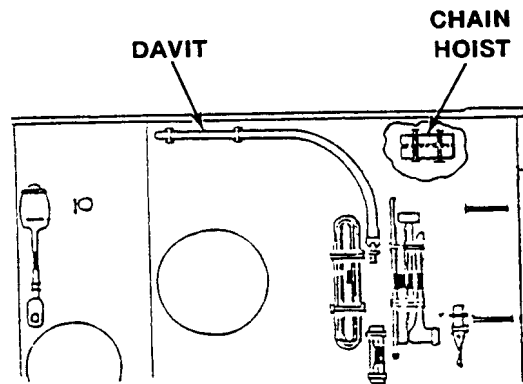

2. Position davit in mounting brackets. Attach chain hoist hooks to davit and lifting bar on generator set.

Continued

WARNING

Hanging loads, heavy parts, and overhead equipment can fall unexpectedly and kill or injure you.

Stay clear of hanging loads, heavy parts, and overhead equipment. Use correct lifting devices. Always have helper guide heavy parts and equipment.

3. Hoist generator set enough to clear enclosure. Swing generator set over enclosure and lower slowly into enclosure.

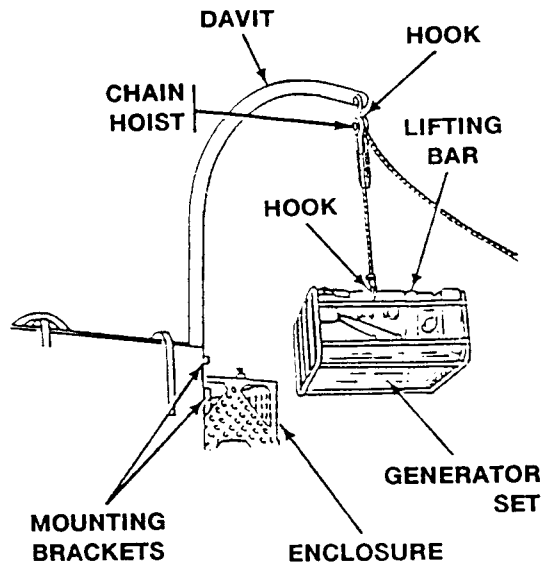

4. Tighten thumbscrews and clamps securing generator set to enclosure. Turn clamps 90 degrees.

REMOVE/INSTALL 4.2 KW GENERATOR SET (M577A3 AND M1068A3 ONLY) —
Continued

0054 00

5. Install waterproof cover on generator set.

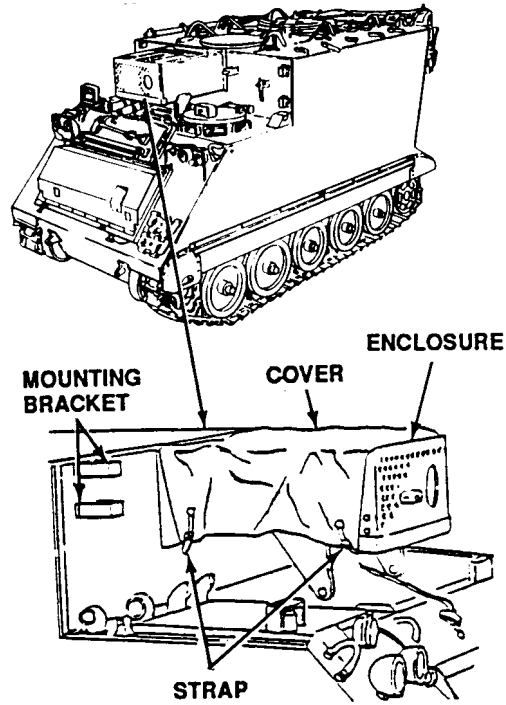

6. Stow davit on top deck. Stow chain hoist in bag on inside of carrier, right side sponson.

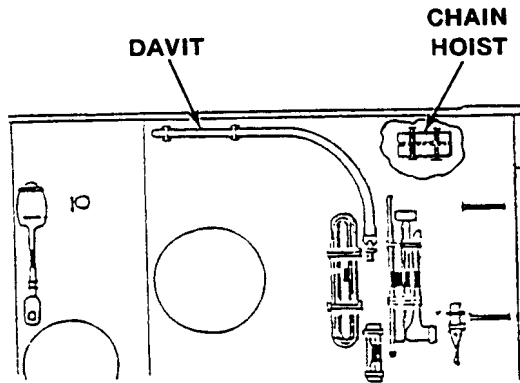

END OF TASK

OPERATE 4.2 KW GENERATOR SET (M577A3 AND M1068A3 ONLY)

0055 00

THIS WORK PACKAGE COVERS:

Operate (page 0055 00-1).

INITIAL SETUP:

Maintenance Level

Operator

Personnel Required

Driver

Crew

Equipment Condition

Carrier stopped

Engine stopped (WP 0024 00)

Generator set removed and on level ground
(WP 0054 00)

References

TM 5-6115-596-14

OPERATE

1. Turn carrier MASTER SWITCH OFF.
2. Remove auxiliary power cable from its stowed position on top deck of carrier

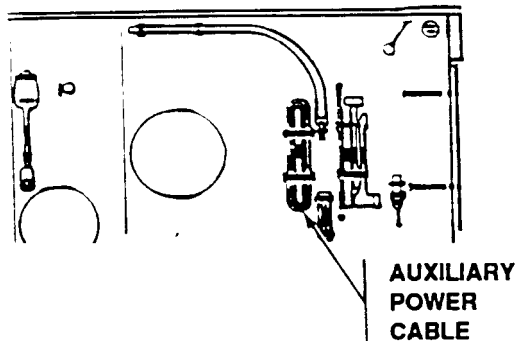
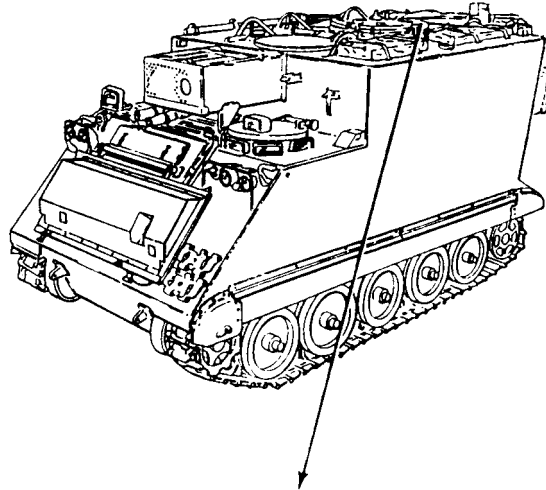

3. Connect auxiliary power cable to auxiliary power receptacle on top deck of carrier near driver's hatch.
4. Unroll auxiliary power cable to its full length.

NOTE

Generator must be level to operate properly.

5. Locate a good position to set up generator set. Dig a shallow hole large enough for generator set. Keep bottom of hole level.

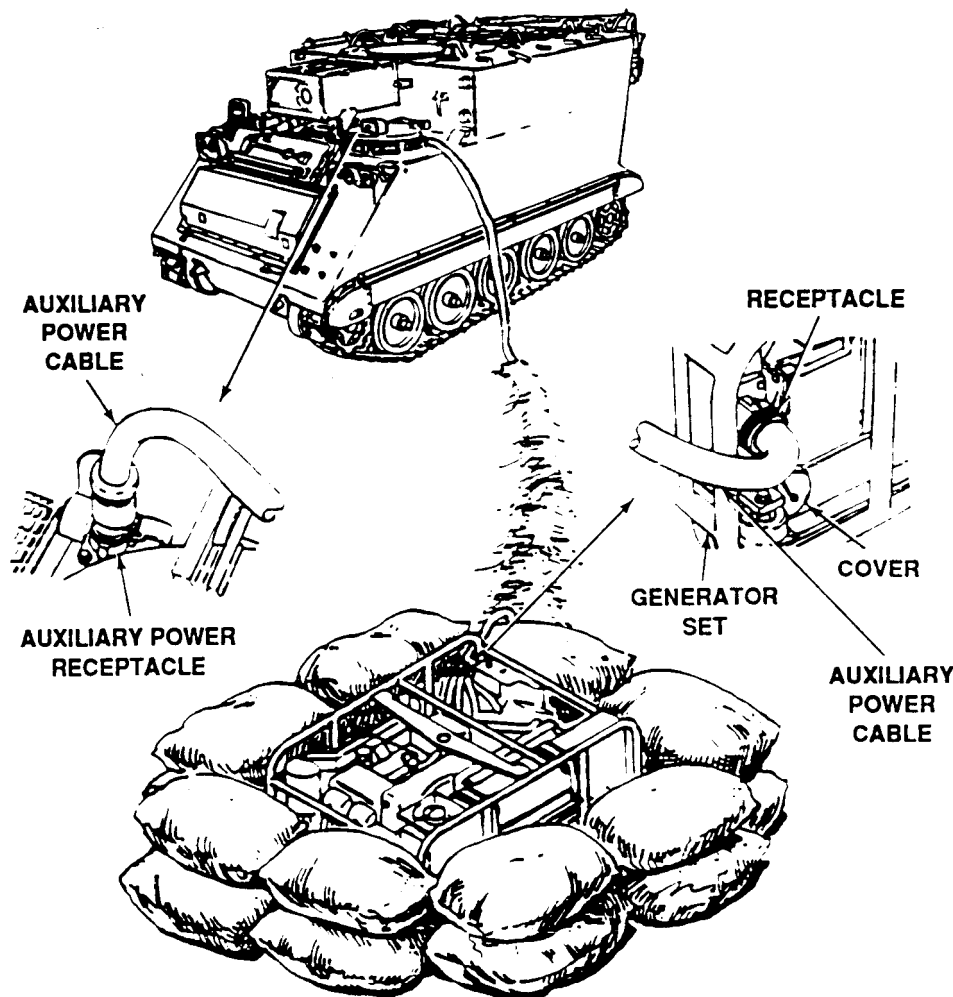

6. Set generator set in hole. Place sand bags around hole to camouflage generator set and help reduce noise during operation. Have crew help.
7. Connect auxiliary power cable to either receptacle on generator set. Make sure auxiliary power cable is concealed and out of the way of personnel.
8. Turn carrier MASTER SWITCH ON.

CAUTION

Use only 83 octane gasoline in the M577A3 and M1068A3 generator sets. Diesel fuel will damage generator.

9. Start and operate the generator set, as described in TM 5-6115-596-14.

10. Shut down generator set, as described in TM 5-6115-596-14.
11. Turn MASTER SWITCH OFF.
12. Disconnect and stow auxiliary power cable.

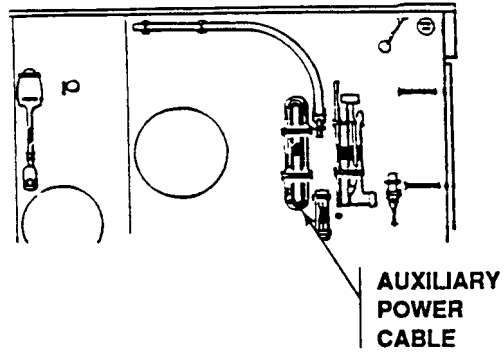

END OF TASK

SET UP COMMAND POST TENT (COVERED EXTENSION) (M577A3 ONLY)

0056 00

THIS WORK PACKAGE COVERS:

- Set Up Tent (page 0056 00-1).
- Add Additional Tents (page 0056 00-5).

INITIAL SETUP:

Maintenance Level

Operator

Equipment Condition

Carrier stopped

Personnel Required

Driver
Crew

SET UP TENT

1. Lower ramp until it is level with carrier floor (WP 0012 00).

NOTE

Get the staking pins and tent lights from their stowed position under the left forward table and set them outside.

2. Unfasten four straps securing tent to top of carrier.

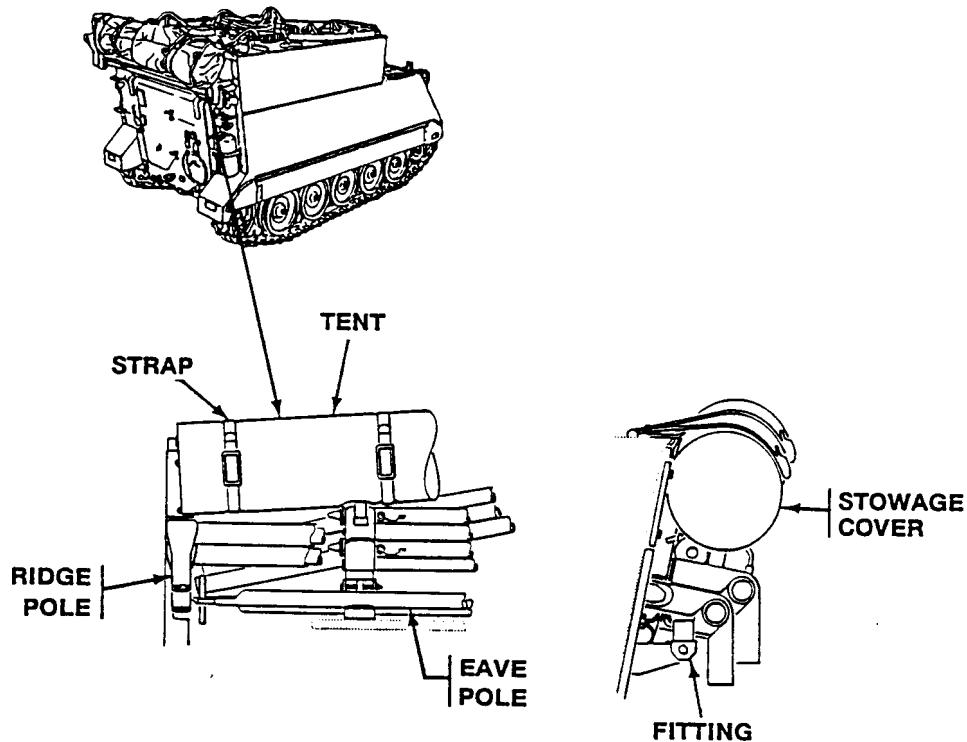

3. Remove framework poles and legs from stowed position at rear of carrier.
4. Arrange poles on ground.

5. Extend eave poles, insert pins, and partially assemble framework.

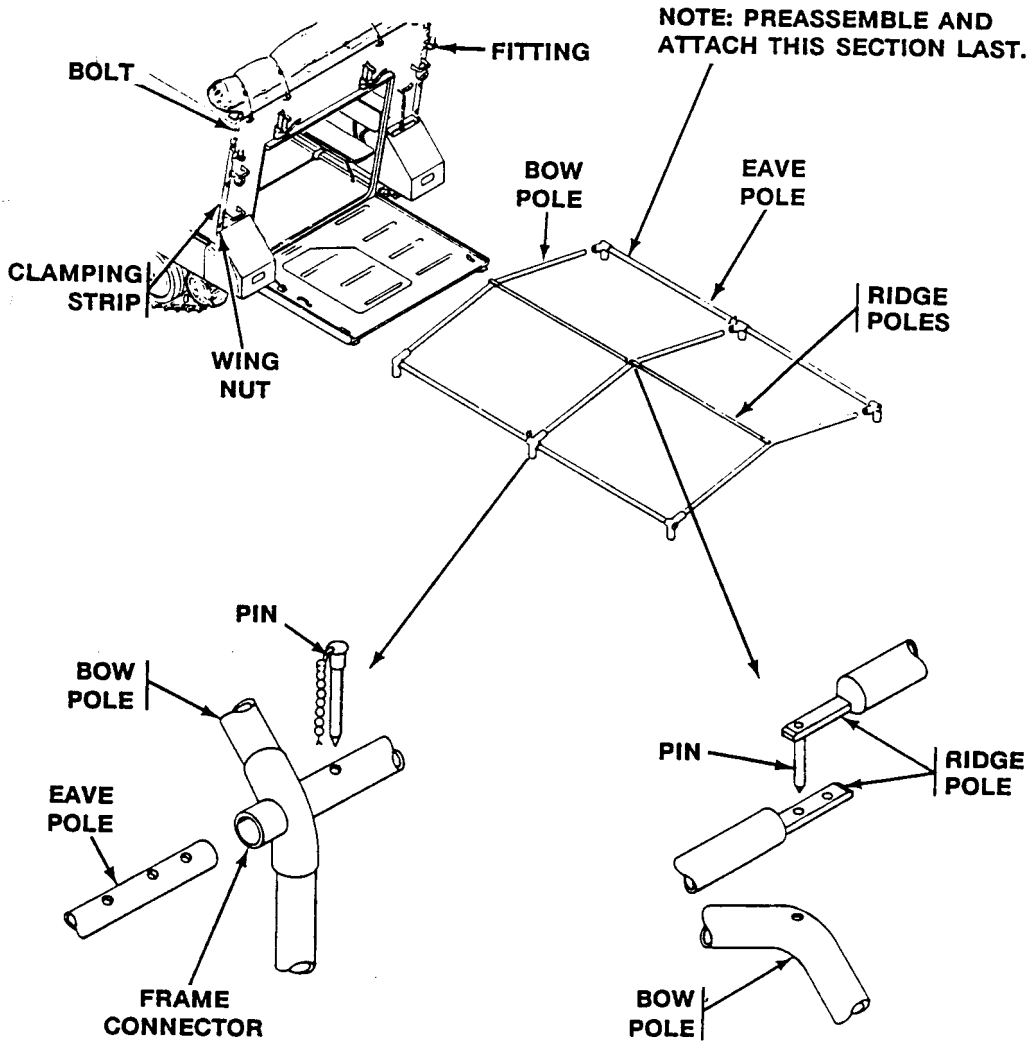

6. Insert ridge pole pins into bow poles.

NOTE

Two men are required on each side of frame to lift it into position on carrier.

7. Attach frame to carrier at two fittings.

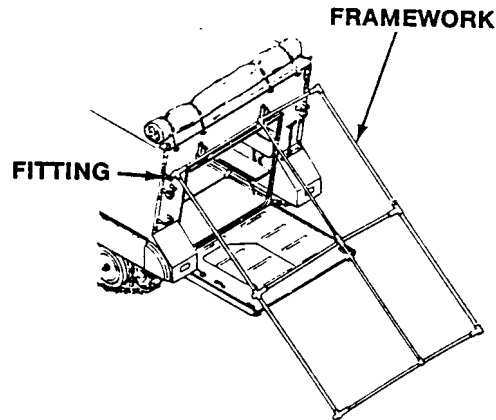
**NOTE**

If you need protection against extreme cold weather, install tent liner. See task: **INSTALL/REMOVE TENT LINER FOR EXTREME COLD WEATHER (WP 0058 00)**.

8. Unroll tent cover along framework, and unfold sides and end.
9. Lift rear of frame assembly and insert both rear legs at the same time.
10. Install two center legs in frame assembly.
11. Adjust all four legs to contour of ground.
12. Loosen the three wingnuts securing clamping strips to hull at each side of ramp.

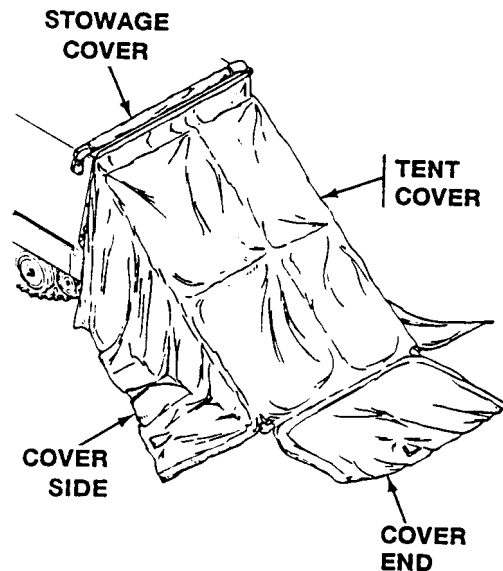

13. Insert beaded edge of cover under clamping strip. Tighten wingnuts. Two soldiers are required (one on top of carrier and one on ground).

14. Raise and lock ramp (WP 0012 00).
15. Zip fastener and tie curtain under carrier.

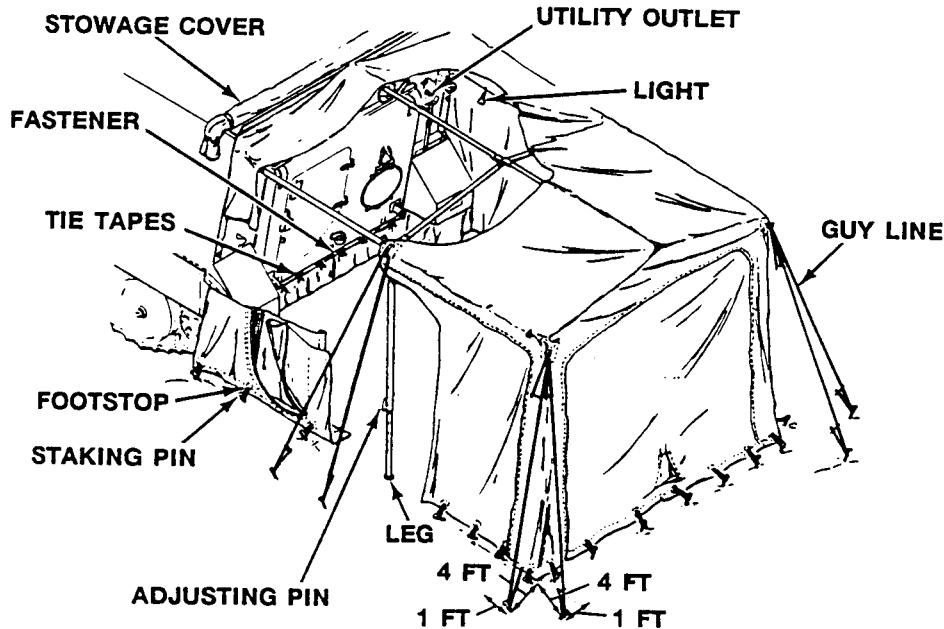

16. Drive 34 staking pins through 34 footstops.
17. Drive eight staking pins for guy lines.
18. Secure and tighten guy lines.
19. Tie tapes around frame assembly legs.
20. Tie stowage cover to top edge of carrier and to sides of tent.
21. Unlock and lower ramp to ground (WP 0012 00).
22. Install electric light assembly and secure with tie.
23. Connect light assembly to one of two utility outlets on either side of ramp.
24. Secure eight straps inside enclosure, along junction of top and side, to frame.

ADD ADDITIONAL TENTS**NOTE**

Many additional tents may be erected and attached as required for tactical operation.

1. Align and erect additional tents to any of three entrances of previously erected tent.
2. Remove entrance covers. Attach tents by zipping entranceways together. Secure with straps.

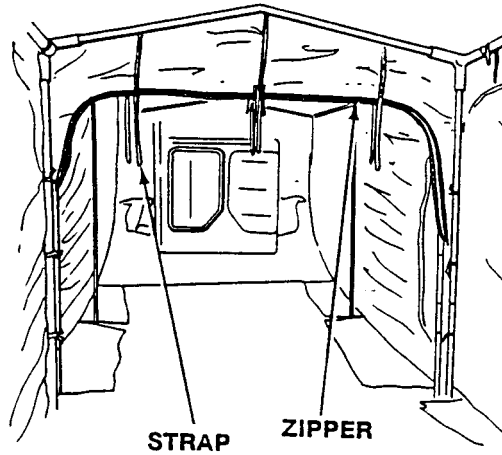
**END OF TASK**

**DISMANTLE/STOW MODULAR COMMAND POST SYSTEM
(MCPS) (M1068A3 ONLY)**

0057 00

THIS WORK PACKAGE COVERS:

- Set up MCPS (page 0057 00-1)
 - Add additional tents (page 0057 00-1)
 - Dismantle/stow MCPS (page 0057 00-1)
-

INITIAL SETUP:

Maintenance Level

Operator

References

TM 10-8340-243-13&P

Personnel Required

Driver

Crew

Equipment Condition

Carrier stopped

SET UP MCPS

1. Lower ramp until it is level with carrier floor (WP 0012 00).
2. To set up MCPS, see TM 10-8340-243-13&P.

ADD ADDITIONAL TENTS

NOTE

Additional tents may be erected and attached as required for tactical operation.

1. To add additional tents, see TM 10-8340-243-13&P.

DISMANTLE/STOW MCPS

1. To dismantle/stow MCPS, see TM 10-8340-243-13&P.

END OF TASK

INSTALL/REMOVE TENT LINER FOR EXTREME COLD WEATHER (M577A3 ONLY)

0058 00

THIS WORK PACKAGE COVERS:

Install Tent Liner (page 0058 00-1).
 Remove Tent Liner (page 0058 00-3).

INITIAL SETUP:

Maintenance Level

Operator

Equipment Condition

Carrier stopped

Personnel Required

Driver
 Crew

INSTALL TENT LINER

1. Partially set up tent (WP 0056 00, Steps 1 - 6).
2. Place rolled up liner over front of tent framework and unroll. Unfold sides and end of liner.

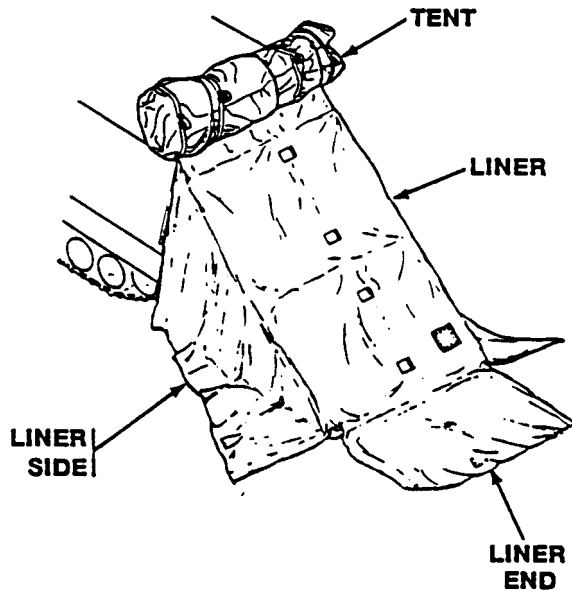

3. Unroll tent along framework. Unfold sides and end of tent over liner.
4. Tie liner to tent by securing six top tapes to six small loops at front and rear tent underside.

INSTALL/REMOVE TENT LINER FOR EXTREME COLD WEATHER (M577A3 ONLY) —
Continued

0058 00

5. Pull tent roof support straps through four square holes in liner and tie straps.

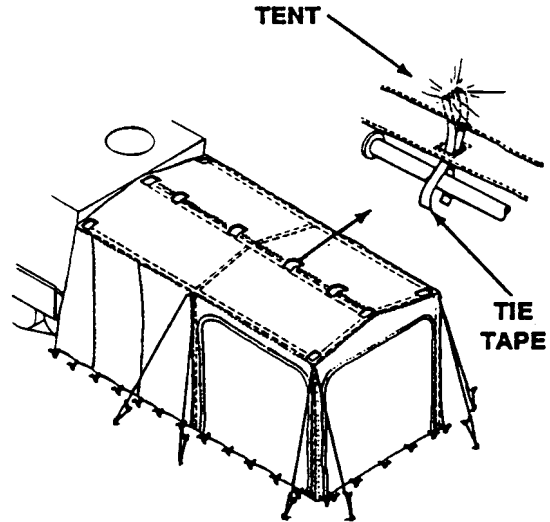

6. Unfold sides and ends of tent and liner, and continue setting up tent (WP 0056 00, Steps 7 - 9).
7. Tie two liner tapes, one on each side above carrier fender, to tapes on tent.
8. Pull cover leg tapes through square holes in liner and tie to framework.

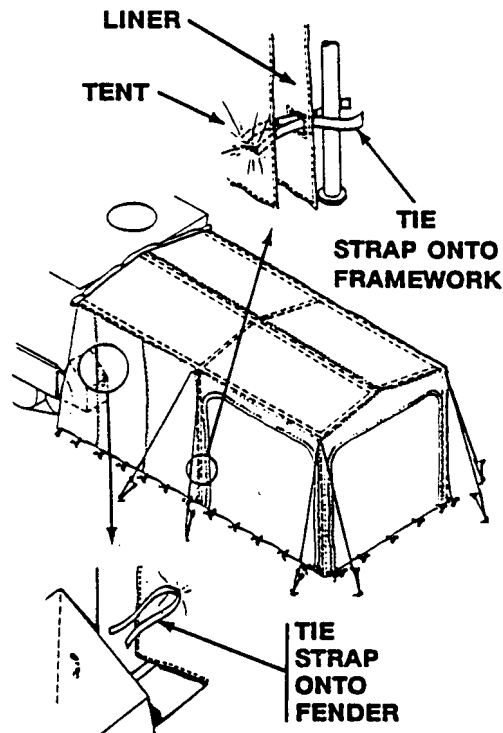

9. Continue setting up tent (WP 0056 00, Steps 10 - 24).

INSTALL/REMOVE TENT LINER FOR EXTREME COLD WEATHER (M577A3 ONLY) —
Continued

0058 00

REMOVE TENT LINER

1. Untie liner tapes at fenders and from top and legs of framework.
2. Dismantle and stow tent (WP 0059 00).
3. Fold tent sides and end over center section of tent. Leave liner in place and carefully withdraw tent leg tapes from square holes of liner.
4. Fold tent guy lines into center section of tent.

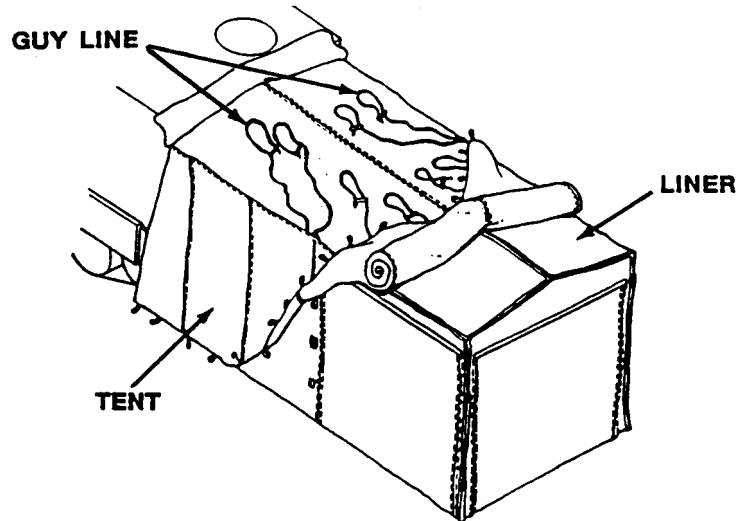

5. Roll tent up framework, leaving liner in place. Carefully withdraw tent roof support straps from square holes in liner.
6. Fold liner sides and end over top of liner, roll liner up framework, and remove.

NOTE

If tent liner will be needed again, roll it up and stow it with tent.

7. Return liner to unit maintenance for stowage.

END OF TASK

**DISMANTLE/STOW COMMAND POST TENT (COVERED EXTENSION)
(M577A3 ONLY)**

0059 00

THIS WORK PACKAGE COVERS:

Dismantle (page 0059 00-1).
Stow (page 0059 00-1).

INITIAL SETUP:

Maintenance Level

Operator

Equipment Condition

Carrier stopped

Personnel Required

Driver

Crew

DISMANTLE TENT

1. Remove tent in reverse order from which it was set up (WP 0056 00).

STOW TENT

WARNING



When stowing the eave poles, secure the split sections together. The inner section can extend and be lost or cause injury to personnel.

CAUTION

Do not stow or fold fabric cover when it is wet. Do not fold pins and poles in with fabric cover.

NOTE

Put the staking pins and light assemblies in their stowed position under the left forward table.

DISMANTLE/STOW COMMAND POST TENT (COVERED EXTENSION) (M577A3 ONLY) —
Continued

0059 00

1. Stow cover, poles, and legs in travel position as shown.

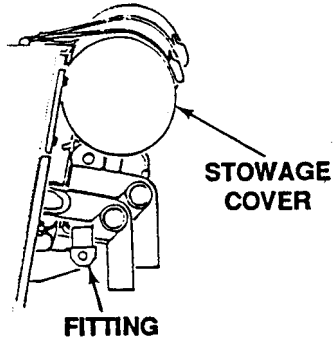

NOTE: PUT THE STAKING PINS AND LIGHT ASSEMBLIES IN THEIR STOWED POSITION UNDER THE LEFT FORWARD TABLE.

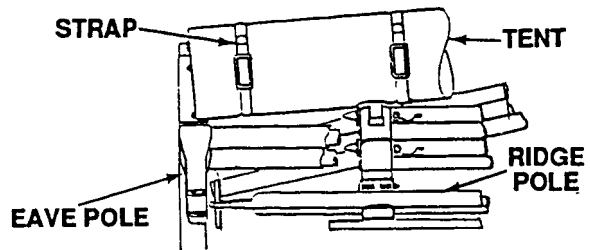

NOTE: AFTER LEGS AND POLES ARE STOWED, TIGHTEN UNTIL SECURE.

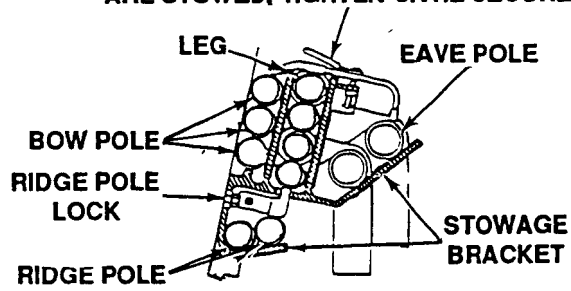

END OF TASK

REFUEL GENERATOR SET (M577A3 AND M1068A3 ONLY)

0060 00

THIS WORK PACKAGE COVERS:

Refuel Generator Set (page 0060 00-1).

INITIAL SETUP:

Maintenance Level

Operator

Personnel Required

Driver

References

TM 5-6115-596-14

Equipment Condition

Engine stopped (WP 0024 00)

Carrier blocked (WP 0042 00)

REFUEL GENERATOR SET

CAUTION

Use only 83 octane gasoline in M577A3 and M1068A3 generator sets.

1. To refuel generator set, see TM 5-6115-596-14.

NOTE

This task applicable to 4.2 KW generator only.

END OF TASK

OPERATE IN EXTREME COLD: BELOW -25° F (-31° C)

0061 00

THIS WORK PACKAGE COVERS:

- Prepare to Operate Carrier in Extreme Cold (page 0061 00-1).
 - Operate Carrier in Extreme Cold (page 0061 00-2).
 - Do's and Don'ts for Operation in Extreme Cold (page 0061 00-5)
-

INITIAL SETUP:

Maintenance Level

Operator

References

FM 21-306

Personnel Required

Driver

Equipment Condition

Engine coolant heater kit installed

PREPARE TO OPERATE CARRIER IN EXTREME COLD

NOTE

DO'S and DON'TS at end of task must be read for operation in extreme cold.

1. Check that driver's hatch cover is closed. See task: OPEN/CLOSE DRIVER'S HATCH COVER (WP 0006 00 or WP 0007 00).
2. Check that cargo hatch cover is closed. See task: OPEN/CLOSE CARGO HATCH COVER (WP 0008 00).
3. Check that commander's hatch cover is closed. See task: OPEN/CLOSE COMMANDER'S HATCH COVER (WP 0009 00).
4. Check that ramp is raised. See task: LOWER/RAISE RAMP (WP 0012 00).
5. Cover the exhaust grill. See task: COVER/UNCOVER INTAKE AND EXHAUST GRILLS (WP 0083 00).
6. Cover intake grill. See task: COVER/UNCOVER INTAKE AND EXHAUST GRILLS (WP 0083 00).
7. Place tarpaulin over carrier.

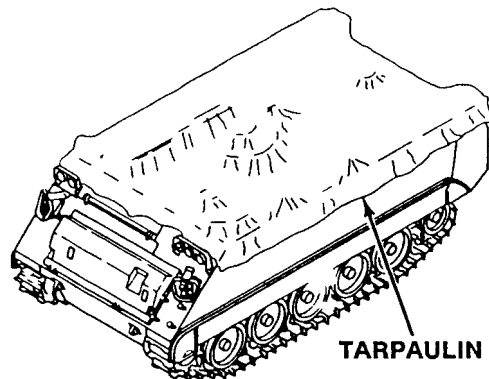

OPERATE CARRIER IN EXTREME COLD

1. Fold tarpaulin back to uncover intake and exhaust grills.

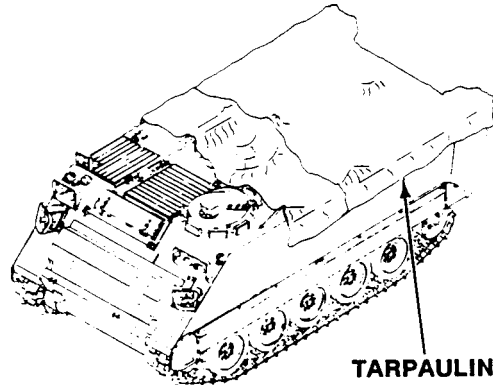

2. OPERATE ENGINE COOLANT HEATER. See task: OPERATE ENGINE COOLANT HEATER BELOW -25°F (-31°C) (WP 0062 00).

NOTE

Exhaust grill should be uncovered and intake grill covered when starting engine. Both personnel and winterization heaters should be turned off before trying to start engine.

3. Cold start engine. Let engine run for 15 minutes. See task: START ENGINE (WP 0021 00).
4. Release parking brake. See task: SET/RELEASE PARKING BRAKE (WP 0020 00).
5. Press down brake pedal and hold thru Step 6.

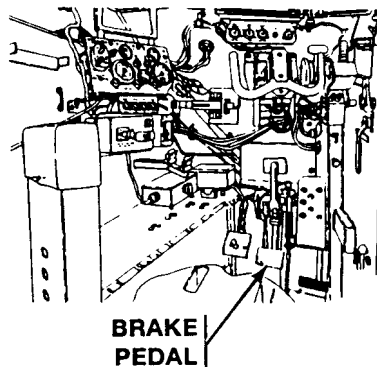

WARNING

Sudden carrier movement can injure personnel. Do not remove foot from brake.

6. Move transmission controller to range 1-2 and hold for 5 minutes while slowly raising engine idle. Raise idle until engine runs smoothly.

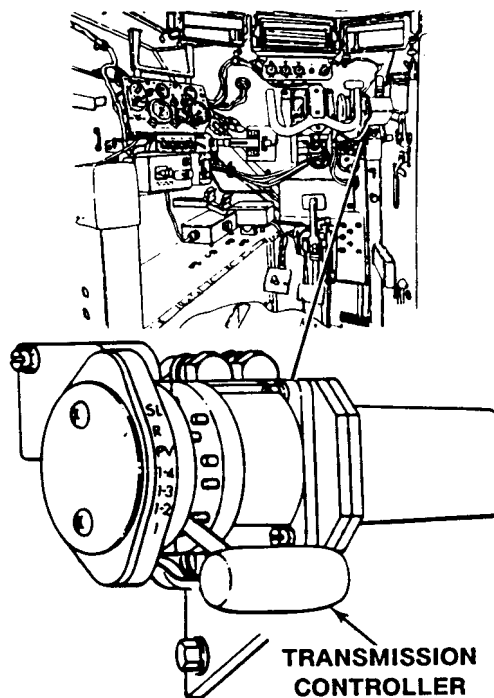

7. Lower engine idle to slow and move transmission controller to SL.
8. Set parking brake. See task: SET/RELEASE PARKING BRAKE (WP 0020 00).
9. Open one or more flaps on intake grill. See task: COVER/UNCOVER INTAKE AND EXHAUST GRILLS (WP 0083 00).

10. Remove tarpaulin from carrier.

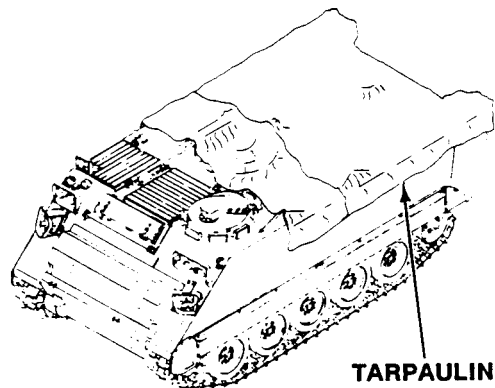

11. Repeat Steps 4 - 6.

CAUTION

Running engine at high speed after cold start could damage engine. Drive carrier slowly for first kilometer.

12. Perform mission. See task: DRIVE CARRIER (WP 0023 00).
 13. If engine coolant temperature gage is above 230°F during mission, do Step 7, Step 8, and Step 14.

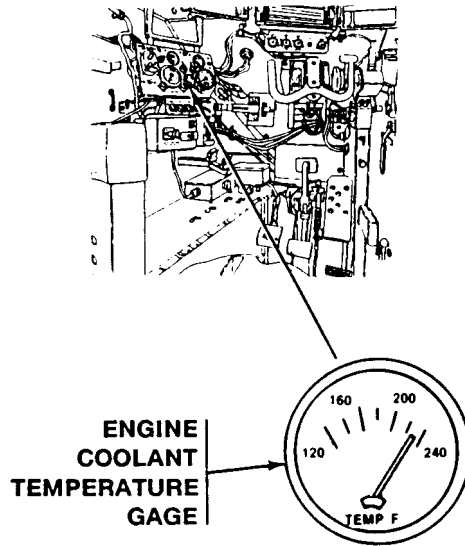

14. Remove cover from intake grill. See task: COVER/UNCOVER INTAKE AND EXHAUST GRILLS (WP 0083 00).
15. Stop engine. See task: STOP ENGINE (WP 0024 00).
16. Remove driver's power plant access panel. See task: REMOVE/INSTALL POWER PLANT ACCESS PANELS (WP 0040 00).

CAUTION

Condensation in fuel tanks and lines can freeze. Fuel lines can get blocked. Drain water from filters and keep fuel tanks full.

17. Drain fuel filters of water (WP 0004 00).
18. Install driver's power plant access panel. See task: REMOVE/INSTALL POWER PLANT ACCESS PANELS (WP 0040 00).
19. If intake grill was uncovered in Step 14, cover intake grill. See task: COVER/UNCOVER INTAKE AND EXHAUST GRILLS (WP 0083 00).
20. Cover exhaust grill. See task: COVER/UNCOVER INTAKE AND EXHAUST GRILLS (WP 0083 00).
21. Place tarpaulin over carrier.

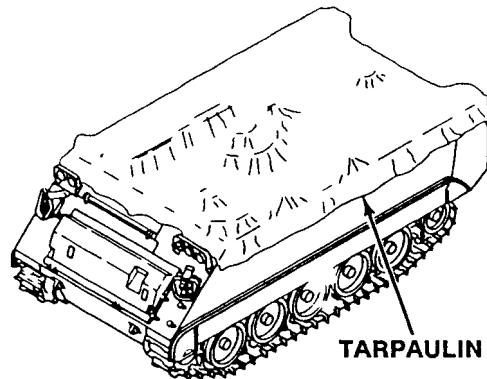

22. Check that driver's hatch cover is closed. See task: OPEN/CLOSE DRIVER'S HATCH COVER (WP 0006 00 or WP 0007 00).
23. Check that cargo hatch cover is closed. See task: OPEN/CLOSE CARGO HATCH COVER (WP 0008 00).
24. Check that commander's hatch cover is closed. See task: OPEN/CLOSE COMMANDER'S HATCH COVER (WP 0009 00).
25. Check that ramp is raised. See task: LOWER/RAISE RAMP (WP 0012 00).

DO'S AND DON'TS FOR OPERATION IN EXTREME COLD

DO'S:

1. Do be alert for the effects of cold on the carrier.
2. Do install air inlet and exhaust grill covers and adjust for conditions.
3. Do start engine coolant heater as soon as you stop for more than a few hours.
4. Do read FM 21-306 to learn about the methods and special hazards of driving on snow, ice, and unusual terrain.

5. Do park in shelter whenever you can. If there's no shelter, park so the carrier doesn't face the wind.
6. Do if you can't park in shelter, put a footing of planks or brush under the tracks so they won't get frozen in. Clean off snow, ice, or mud as soon as you can.
7. Do drain fuel filters as soon as you can. Close valves when clean fuel appears.
8. Do fill the fuel tanks as soon as you can. Water collects in an empty tank when it cools down. Ice will block fuel flow.
9. Do keep the carrier covered as much as you can. Use tarpaulins or anything available to protect the carrier. Cover machine gun when you're not using it. Keep gun clean and lightly lubed.
10. Do remove drain plugs when water collects in hull.
11. Do your AFTER operation preventive maintenance checks and services (PMCS).

DON'TS:

1. Don't operate lights or electrical equipment for very long when coolant heater is ON.
2. Don't run engine while coolant heater is operating.
3. Don't let the ends of tarpaulins touch the ground. They could freeze in place.
4. Don't touch external metal surfaces with bare hands or your tongue. They could freeze to the metal surface.

END OF TASK

OPERATE ENGINE COOLANT HEATER (BELOW -25°F (-31°C))

0062 00

THIS WORK PACKAGE COVERS:

- Turn Coolant Heater On (page 0062 00-1).
 - Turn Coolant Heater Off (page 0062 00-4).
-

INITIAL SETUP:

Maintenance Level

Operator

Personnel Required

Driver

Equipment Condition

- Engine coolant heater kit installed
 - Trim vane lowered (WP 0039 00)
 - Power plant access door opened (WP 0011 00)
 - Fuel tanks manual shutoff valves open (WP 0004 00)
-

TURN COOLANT HEATER ON

1. Open coolant pump shutoff valve and coolant heater shutoff valve.

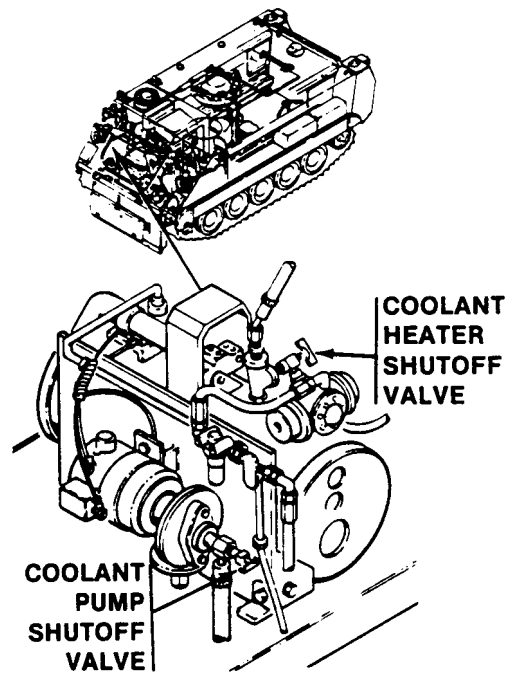

- Open coolant heater fuel supply valve.

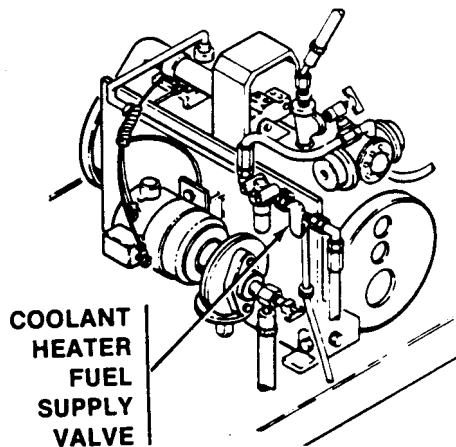

CAUTION

Overheating will damage batteries. Do not use coolant heater if temperature is above -25°F (-31°C).

Carrier batteries can discharge. Do not operate carrier lights, radios, or other electrical equipment while coolant heater is running.

- Press PRESS-TO-TEST switch. Check that indicator light comes on.
- Move RUN-OFF-START switch to START. Hold switch in START until indicator light comes on.

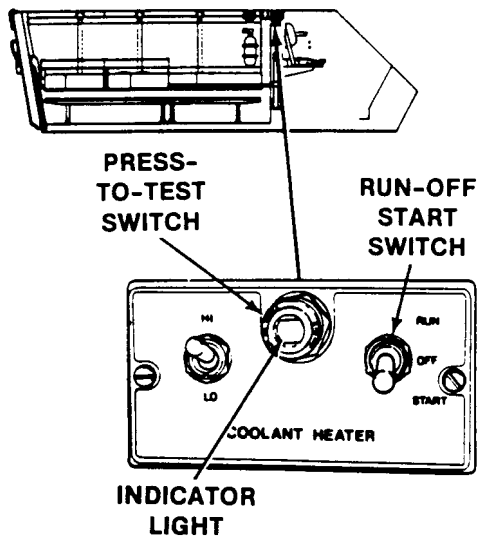

5. Move RUN-OFF-START switch to RUN as soon as indicator light comes on. Do not stop in OFF position.

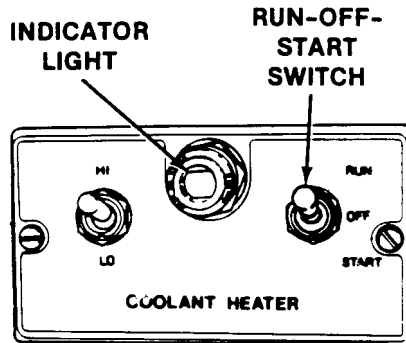

6. If coolant heater does not start, repeat Step 4 and Step 5. If coolant heater does not start after three tries, troubleshoot heater (WP 0089 00).

NOTE

Coolant heater always starts at low heat. It switches to high heat if HI-LO switch is set to HI.

7. Move HI-LO switch to HI or LO.

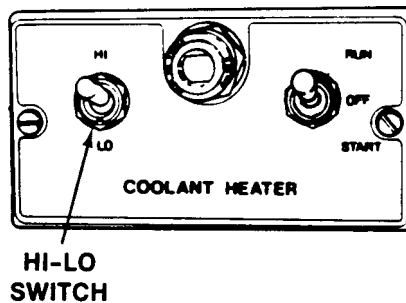

NOTE

When HI-LO switch is at HI, heater will automatically go to low heat if coolant temperature reaches 190°F (88°C). It will go back to high heat if coolant temperature drops to 120°F (49°C). If coolant reaches a temperature of 245°F to 260°F (118° to 126°C), heater will stop and must be restarted.

TURN COOLANT HEATER OFF

NOTE

When coolant heater is turned off, blower will run until heater is purged of fuel and burner is cool. Indicator light will stay on until blower stops. Driver should stay in carrier until blower stops.

1. Move RUN-OFF-START switch to OFF.
2. Allow coolant heater to purge itself.
3. Close coolant pump shutoff valve and coolant heater shutoff valve.

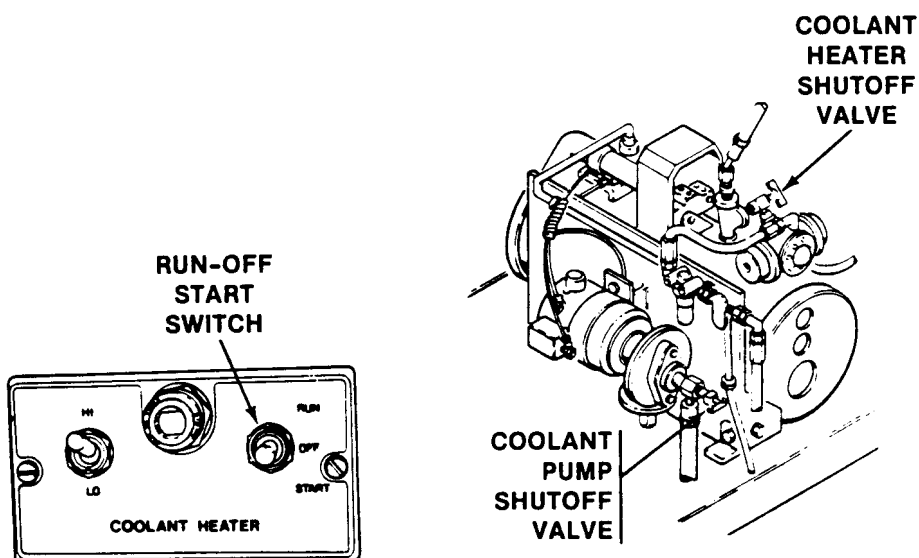

4. Close power plant access door. See task: OPEN/CLOSE POWER PLANT ACCESS DOOR (WP 0011 00).
5. Stow trim vane. See task: LOWER/STOW TRIM VANE (WP 0039 00).

CAUTION

Carrier batteries can discharge. If carrier is not to be driven after 12 hours of running coolant heater, start and run engine until all batteries are fully charged.

NOTE

Always turn coolant heater off and close coolant shutoff valves before starting engine.

6. If needed, start and run engine to charge batteries. See task: START ENGINE (WP 0021 00).

END OF TASK

FORD WATER UP TO 40 INCHES DEEP

0064 00

THIS WORK PACKAGE COVERS:

Ford Water Up To 40 Inches Deep (page 0064 00-1).

INITIAL SETUP:

Maintenance Level

Operator

Personnel Required

Driver
Crew

Tools and Special Tools

Socket Wrench Adapter (WP 0102 00, Item 1)
Socket Wrench Handle (WP 0102 00, Item 30)
Socket Wrench, 1/2 × 3/4 inch (WP 0102 00, Item 49)

Equipment Condition

Engine stopped (WP 0024 00)
Carrier tracks blocked (WP 0042 00)

FORD WATER UP TO 40 INCHES DEEP

WARNING

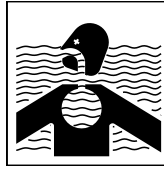

When water depth is unknown or deeper than 40 inches (3.4 feet), do not attempt to ford stream. Carrier may sink and personnel could drown. See task: PREPARATION BEFORE WATER OPERATION (WP 0066 00).

WARNING



Personnel could be killed or injured if carrier moves with someone under it. Make sure engine is stopped, parking brake set, and carrier tracks blocked before crawling under carrier.

1. Check that access covers, drain covers, and final drive drain plugs are in place, straight, and tight. Use socket wrench handle and adapter to check or install final drive drain plugs.

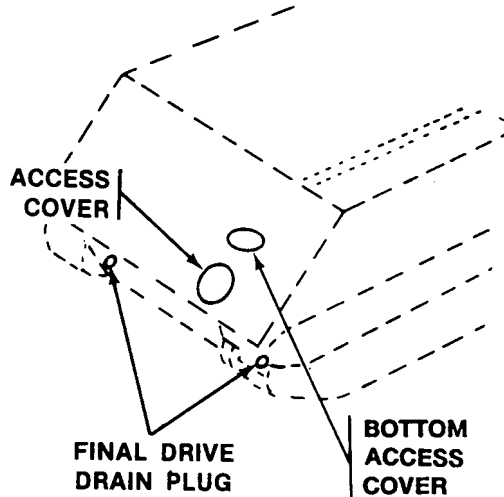

2. Check bilge pumps operation. See task: SERVICE BILGE PUMPS (WP 0096 00).
3. Choose spot to enter and exit water. Look for firm ground without rocks, stumps, or other obstacles. Avoid steep slopes and soft ground.
4. Unblock carrier tracks. See task: BLOCK/UNBLOCK CARRIER TRACKS (WP 0042 00).
5. START ENGINE (WP 0021 00).
6. Place BILGE PUMPS switch ON.

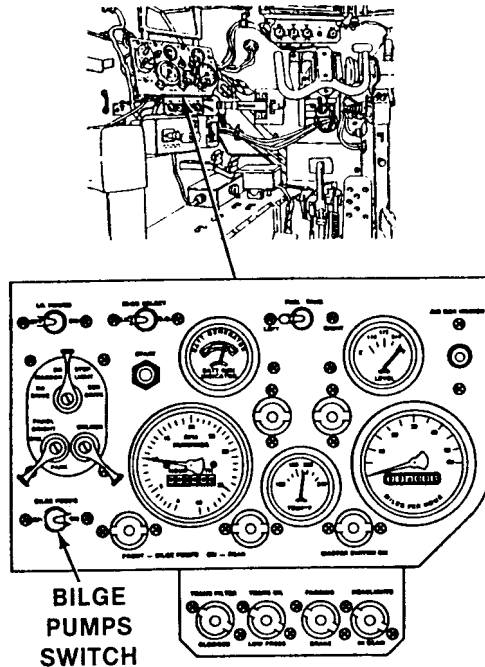

7. Place transmission controller in 1-2 range and enter water. See task: DRIVE CARRIER (WP 0023 00).

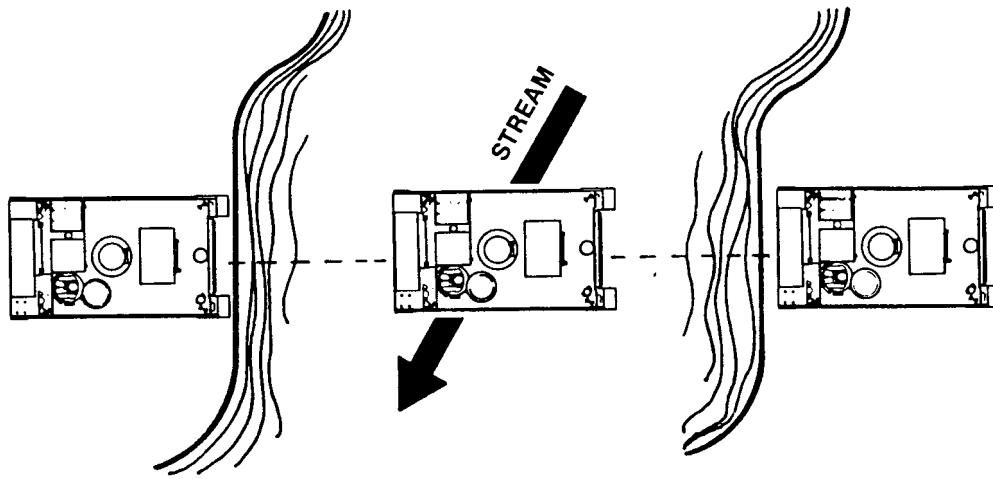

8. Proceed slowly. Watch out for obstacles under water.
9. Exit water. After bilges empty, place BILGE PUMPS switch to OFF.

END OF TASK

PERFORM POST-FORDING OPERATIONS

0065 00

THIS WORK PACKAGE COVERS:

Perform Post-Fording Operations (page 0065 00-1).

INITIAL SETUP:

Maintenance Level

Operator

Equipment Condition

Carrier has been driven in water (WP 0064 00)

Personnel Required

Driver
Crew

PERFORM POST-FORDING OPERATIONS

1. Drive carrier to firm, level ground. See task: DRIVE CARRIER (WP 0023 00).
2. Place BILGE PUMPS switch OFF when water stops coming out bilge outlets.

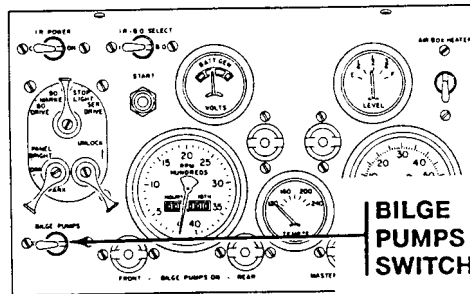

3. STOP ENGINE (WP 0024 00).
4. Check trim vane for damage. Stow trim vane. See task: LOWER/STOW TRIM VANE (WP 0039 00).
5. Check for water in final drive oil (WP 0090 00). If bubbles or white color are seen on dipstick, oil has water in it. Notify unit maintenance.
6. Lubricate carrier chassis (WP 0090 00) as soon as tactical situation permits.

CAUTION

Heater can be damaged during flushing if water gets into inlet or exhaust pipes. Cover heater inlet and exhaust pipes before flushing carrier.

Do not directly or indirectly wash power enclosure, power supplies, computer equipment, or electrical outlets on M1068A3. Electrical shorts may occur when operated next time.

Do not directly or indirectly wash the weapon station, external or internal radio equipment, power enclosure, or computer equipment on the M1068A3.

7. If carrier has been in salt water, flush outside with fresh water. Remove all drain plugs and flush bilges with fresh water. Keep water away from radios and all electrical wiring. Install drain plugs.

END OF TASK

OPERATE CARRIER OVER ROUGH TERRAIN

0073 00

THIS WORK PACKAGE COVERS:

- Drive Carrier Over Trenches (page 0073 00-2)
- Drive Carrier Over Obstacles (page 0073 00-3).
- Drive Carrier On Grades (page 0073 00-4)
- Drive Carrier On Side Slopes (page 0073 00-4).
- Drive Carrier On Snow, Ice, Or Mud (page 0073 00-5)
- Park Carrier On Snow, Ice, Or Mud (page 0073 00-6)

INITIAL SETUP:

Maintenance Level

Operator

Equipment Condition

Engine started (WP 0021 00)

Personnel Required

Driver
Crew

WARNING

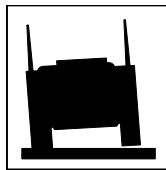

Carrier can roll over and kill or injure personnel. Avoid high speeds and sudden turns when driving on hills or rough terrain. Wear seat belts.

WARNING



Do not attempt to change carrier forward or reverse movement by shifting until carrier comes to a complete stop. Above four miles per hour, if you attempt to shift into reverse (or forward), the carrier will continue in the direction you are moving when you attempted to make the change. Failure to follow the above instructions, could result in injury or death to personnel, and destruction of equipment or property.

NOTE

The crossdrive transmission is designed not to change direction of movement at speeds above four miles per hour. If you attempt to shift into reverse while moving forward above four miles per hour the transmission will not go into reverse even with the shift lever set to “R” (reverse), and the carrier will continue to move forward when you accelerate. Likewise, if you attempt to shift into a forward gear while moving above four miles per hour in reverse, the carrier will continue to move in reverse when you accelerate.

DRIVE CARRIER OVER TRENCHES**CAUTION**

Carrier will get stuck in trenches wider than 5 1/2 ft (1.67m). Do not cross trenches wider than 5 1/2 ft (1.67m).

1. Place transmission controller in range 1 or 1-2.

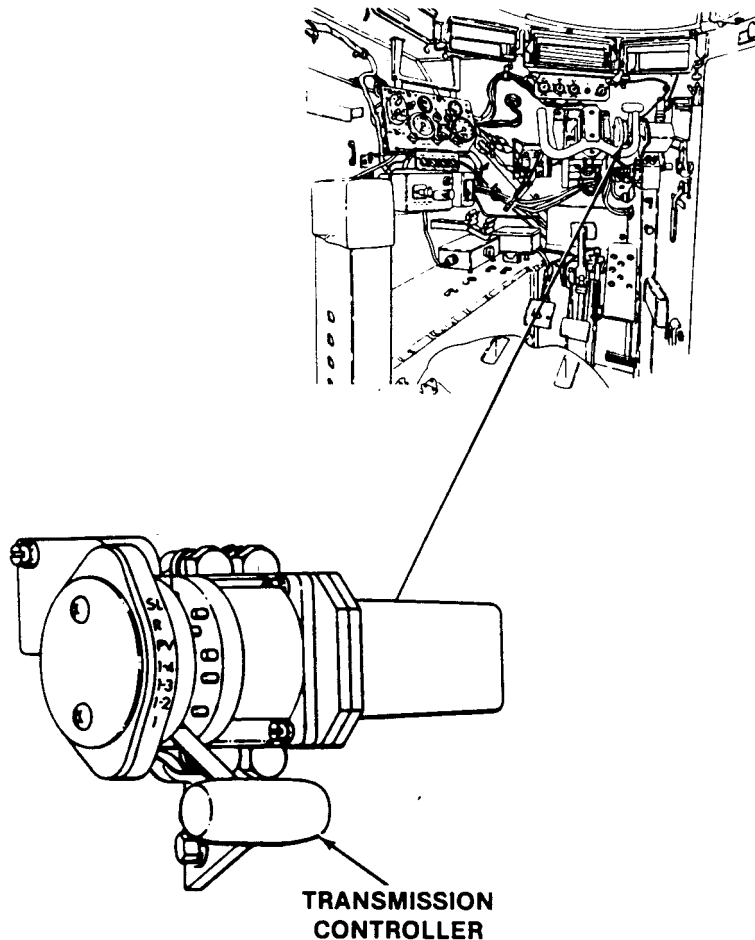

2. Approach trench straight on and drive slowly over trench. Accelerate when track contacts far side of trench.

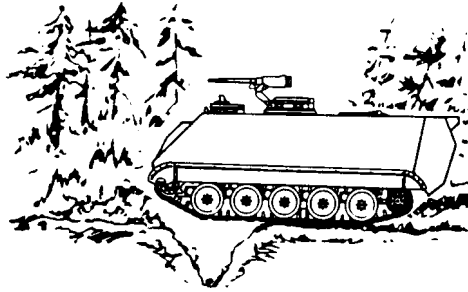

DRIVE CARRIER OVER OBSTACLES

CAUTION

Obstacles higher than 24 inches (61 cm) can damage carrier. Do not drive over obstacles higher than 24 inches.

1. Place transmission controller in range 1 or 1-2.

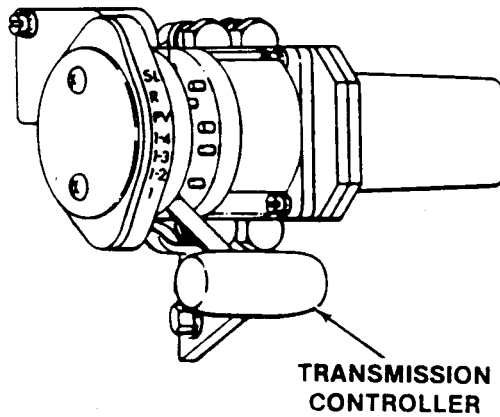

2. Approach obstacle straight on and drive slowly over obstacle.

DRIVE CARRIER ON GRADES

1. Place transmission controller in range 1-2 for grades up to 30% and range 1 for grades from 30% to 60%.

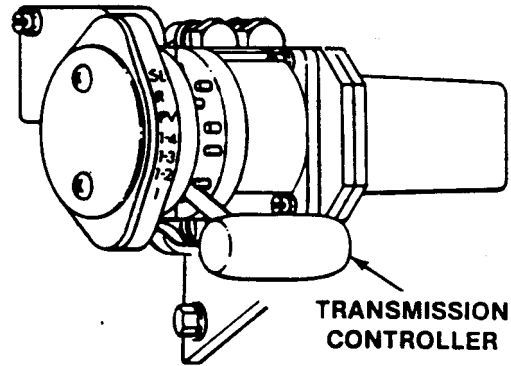
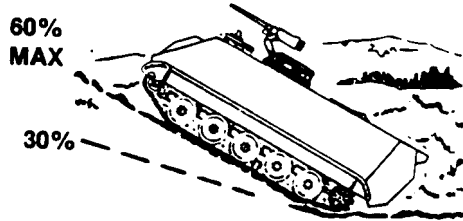

2. Accelerate as carrier climbs a grade. Decelerate when you reach top of grade and during descent.

DRIVE CARRIER ON SIDE SLOPES

WARNING

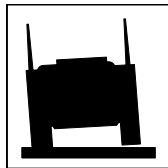

Carrier can roll over and kill or injure personnel. Do not drive on side slopes steeper than 30%.

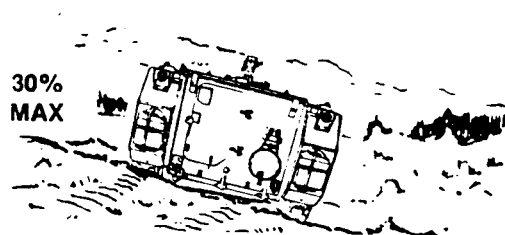

1. Place transmission controller in range 1 or 1-2.

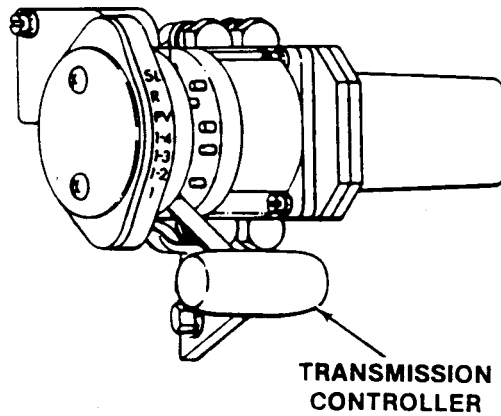

2. Steer in a series of small wide turns rather than one sharp turn.

DRIVE CARRIER ON SNOW, ICE, OR MUD

CAUTION

Sharp turns on snow, ice, or mud can cause carrier to throw a track. Make a series of small wide turns instead of one sharp turn.

NOTE

If you operate often in snow, ice, mud or heavy brush, have unit maintenance remove the track shrouds.

Do not drive on snow covered grades unless you have to. If you do, go as straight up and down the slope as you can.

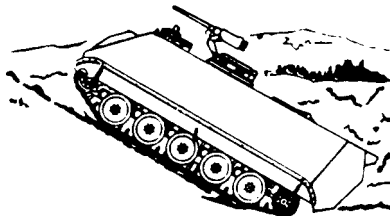

1. Use a low transmission range that moves carrier smoothly without digging in. Drive slowly to avoid skidding.
2. Slow carrier smoothly before making a turn.

3. If carrier breaks through crest of deep snow or soft soil, steer carrier straight to get back on crest.

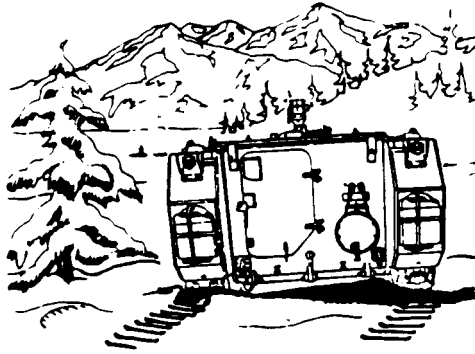
**PARK CARRIER ON SNOW, ICE, OR MUD**

1. If possible, stop carrier on firm surface.
2. When mission is completed, park carrier in a sheltered area with front of carrier faced away from the wind.
3. Clear snow, ice, and mud off road wheels and tracks after parking.
4. If carrier is parked in low area where water may freeze under tracks, put brush or branches under tracks.

END OF TASK

**OPERATE CARRIER IN EXTREME HEAT, HUMIDITY, OR SALTY
CONDITIONS**

0074 00

THIS WORK PACKAGE COVERS:

Operate Carrier (page 0074 00-2).

INITIAL SETUP:

Maintenance Level

Operator

Personnel Required

Driver

WARNING



Vehicle operation during hot weather may result in heat stress to crew members. Crew members should limit their exposure to high temperature and humidity based on TB MED 507. Open door for ventilation, if appropriate.

OPERATE CARRIER IN EXTREME HEAT, HUMIDITY, OR SALTY CONDITIONS

1. Check gages and warning lights often when driving. If any warning light comes on, STOP ENGINE (WP 0024 00). Troubleshoot problem (WP 0089 00).

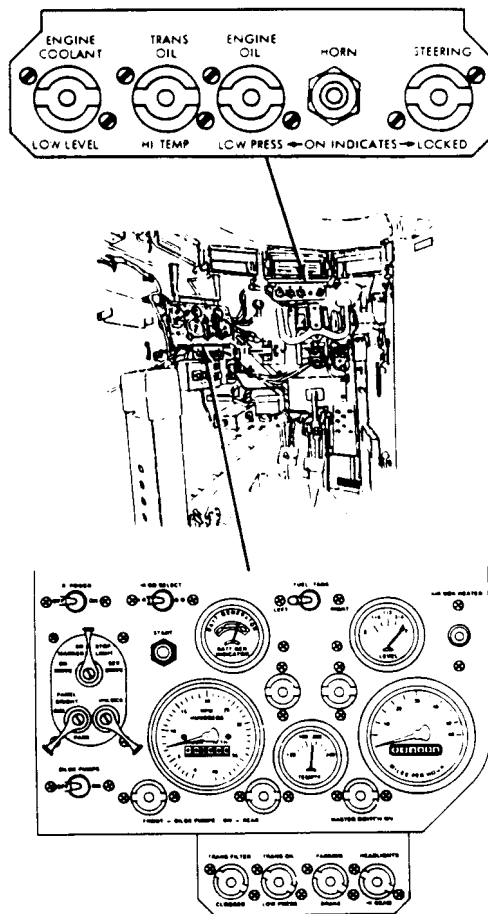

2. Check engine coolant level often. See task: CHECK/FILL COOLING SYSTEM (WP 0097 00).

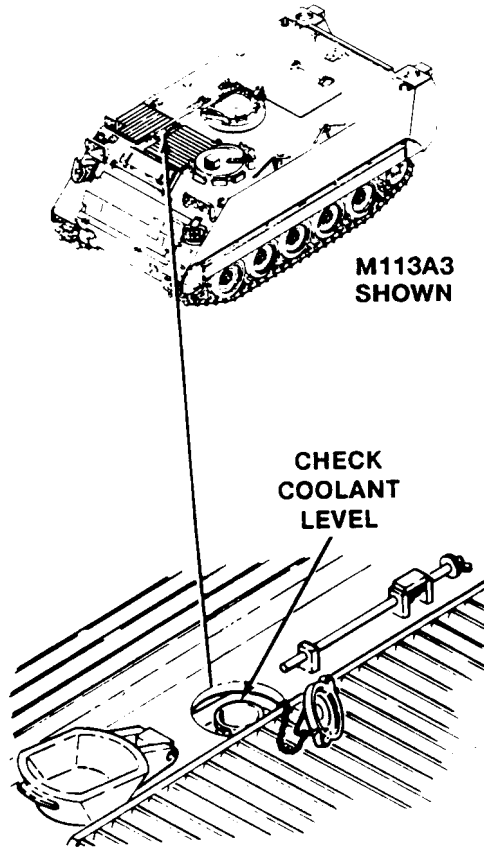

OPERATE CARRIER IN EXTREME HEAT, HUMIDITY, OR SALTY CONDITIONS —
Continued

0074 00

3. Check air cleaner indicator often. If at any time only red shows in the window, notify unit maintenance.

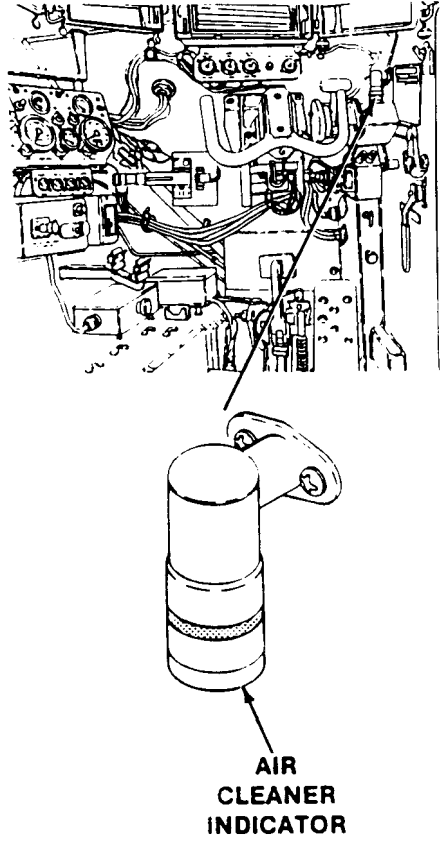

4. Check level of water in batteries. See task: CHECK CARRIER BATTERIES (WP 0095 00).

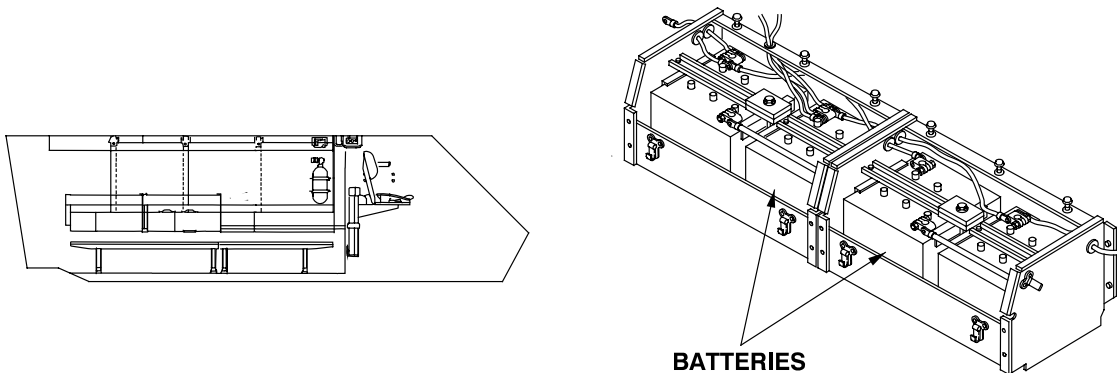

M113A3, M1059A3 SHOWN

5. Don't drive in any transmission range below 1-4 when you don't have to.

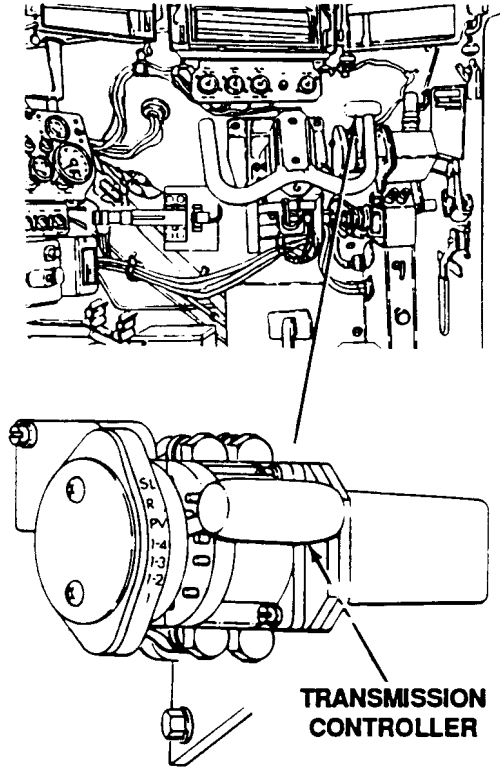

6. Don't let dirt, sand, or bugs build up in the radiator fins. Have unit maintenance clean fins with water pressure.
7. Lubricate frequently (WP 0090 00). Heat, sand, dust, humidity, and salt all have a bad effect on lubricants and moving parts.
8. Stop and fix any problem as soon as it comes up, or as soon as tactical situation allows.
9. Keep carrier clean. Fungus and mildew can grow fast in conditions of high heat and humidity. Look carrier over and clean it often.

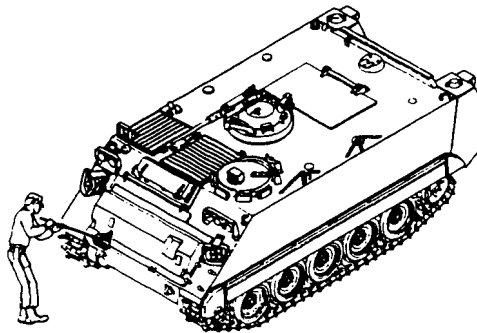

OPERATE CARRIER IN EXTREME HEAT, HUMIDITY, OR SALTY CONDITIONS —
Continued

0074 00

10. Keep carrier in shelter or shade as much as possible. Cover carrier with tarpaulins when it is parked. If you cannot cover entire carrier, at least cover intake and exhaust grilles. See task: COVER/UNCOVER INTAKE AND EXHAUST GRILLES (WP 0083 00).

**END OF TASK**

BYPASS DEFECTIVE TRANSMISSION CONTROLLER

0075 00

THIS WORK PACKAGE COVERS:

Bypass defective transmission controller (page 0075 00-1).

INITIAL SETUP:

Maintenance Level

Operator

Personnel Required

Driver

Equipment Condition

Parking brake set (WP 0020 00)

Engine started (WP 0021 00)

BYPASS DEFECTIVE TRANSMISSION CONTROLLER

NOTE

If carrier does not move in any shift lever position, transmission controller may be defective. Do Steps 1 - 5 below to bypass defective transmission controller allowing you to drive carrier.

1. Disconnect wiring harness from transmission controller.

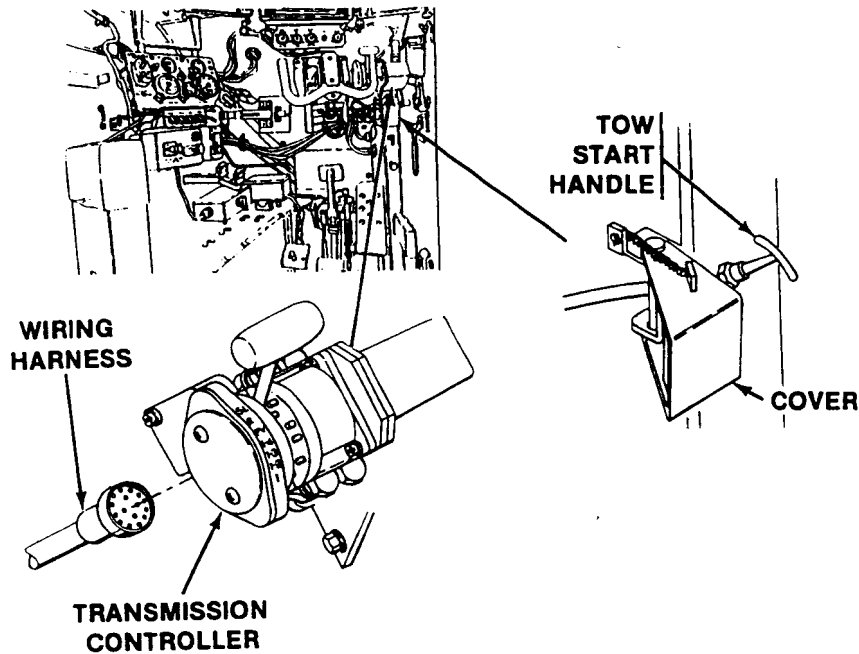

2. Open tow start handle cover.

NOTE

With transmission controller wiring harness disconnected, transmission will shift to 1-4 range when tow start handle is pulled. Carrier will move if parking brake is not set.

3. Pull tow start handle momentarily and release to engage transmission. Release parking brake (WP 0020 00), close cover, and drive carrier to required destination.

4. Stop engine (WP 0024 00).
5. Notify unit maintenance of defective transmission controller as soon as tactical situation permits.

END OF TASK

SECURING INOPERABLE/UNSAFE RAMP

0076 00

THIS WORK PACKAGE COVERS:

Securing inoperable/unsafe ramp (page 0076 00-1).

INITIAL SETUP:

Maintenance Level

Operator

Personnel Required

Driver

Equipment Condition

Engine stopped (WP 0024 00)

Carrier tracks blocked (WP 0042 00)

SECURING INOPERABLE/UNSAFE RAMP

WARNING



An inoperable/unsafe ramp can fall and kill you. Do not attempt to manually raise or lower an inoperable/unsafe ramp. Notify unit maintenance to raise or lower an inoperable/unsafe ramp.

NOTE

This task is for all carriers, except M113A3 with armor.

1. Close ramp access door and secure with combat lock. See task: OPEN/CLOSE RAMP ACCESS DOOR (WP 0005 00).

- Secure combat lock using padlock in tool bag.

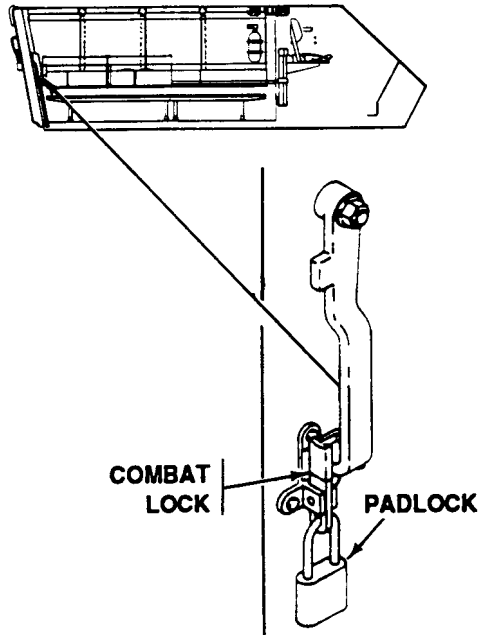

- If ramp is lowered when it becomes inoperable, notify unit maintenance to raise inoperable ramp using powered lifting equipment.
- Secure ramp closed using ramp lock. See task: LOWER/RAISE RAMP (WP 0012 00).

WARNING

An inoperable/unsafe ramp can fall and kill you. Do not remove any device securing an inoperable/unsafe ramp. Notify unit maintenance to remove lifting equipment.

NOTE

Steps 5 - 6 are for M113A3 and M1064A3 only.

5. With ramp lock engaged and lifting equipment holding ramp up, install tow hook on antenna brush guard and secure with headed pin and retaining clip. Install tow cable on tow hook.
6. Install opposite end of tow cable on tow hook. Install tow hook with tow cable attached to right rear towing eye and secure with headed pin and retaining clip.

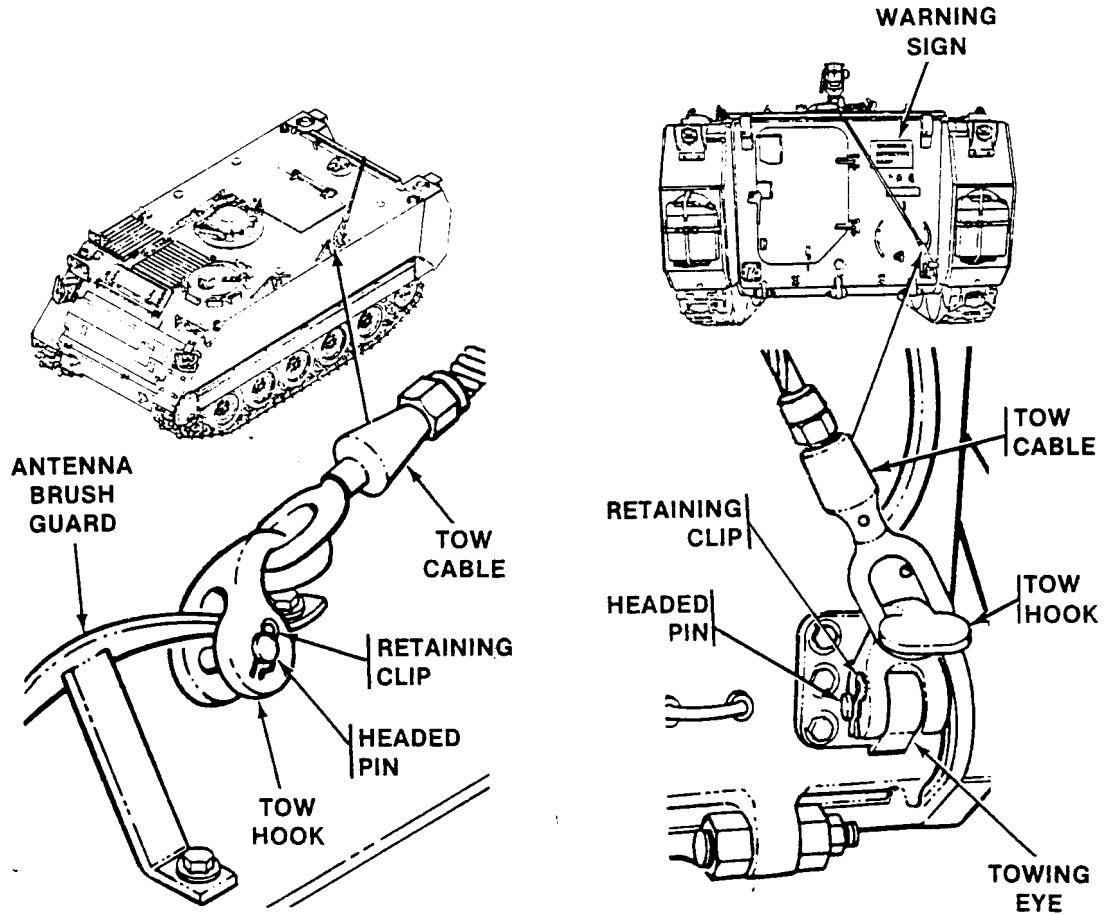

NOTE

Steps 7 - 8 are for M577A3 and M1068A3 only.

7. With ramp lock engaged and lifting equipment holding ramp up, install tow hooks in right-hand towing eye and rear left-hand lifting eye.
8. Route tow cable through tow pintle and connect to both tow hooks with headed pins and safety clips.

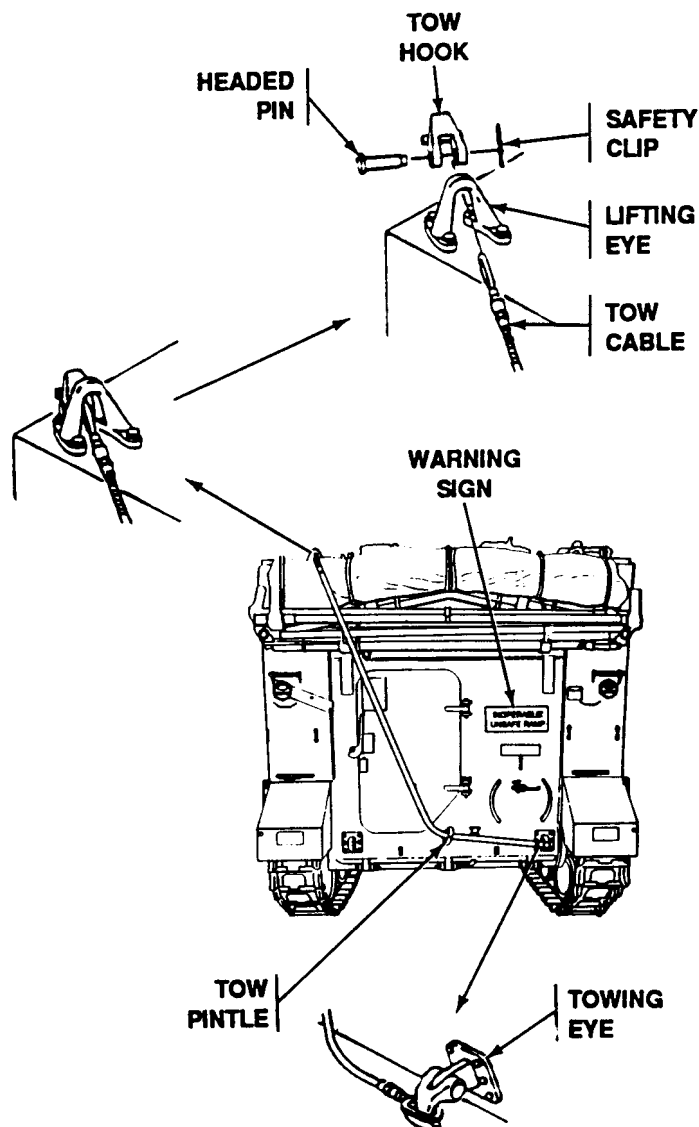

9. If possible, post a warning sign on ramp identifying hazardous condition.
10. Record fault. Notify unit maintenance.

END OF TASK

TOWING DISABLED CARRIER

0077 00

THIS WORK PACKAGE COVERS:

- Install Tow Bar on Disabled Carrier and Recovery Vehicle (page 0077 00-2).
 - Install Tow Cables on Disabled Carrier and Recovery Vehicle (page 0077 00-3).
 - Tow Disabled Carrier (page 0077 00-4).
 - Remove Tow Bar From Disabled Carrier and Recovery Vehicle (page 0077 00-5).
 - Remove Tow Cables From Disabled Carrier and Recovery Vehicle (page 0077 00-6).
-

INITIAL SETUP:

Maintenance Level

Operator

Personnel Required

Driver (2)

Helper (H) (4)

Tools and Special Tools

Crowbar (WP 0102 00, Item 13)

Tow Cable (WP 0102 00, Item 7)

Recovery vehicle

WARNING



A towed carrier does not have steering until it reaches 3 mph plus. Personnel can be killed or injured. Use tow bar or two tow cables and use brakes to stop carrier, when necessary.

WARNING



Steering and braking control are lost when final drive shafts are disconnected. Personnel can be killed or injured. Do not use tow cables when drive shafts have been disconnected.

WARNING



Carrier could roll and kill or injure personnel when final drive shafts are disconnected. Block carrier tracks and connect tow bar to disabled carrier and to tow vehicle before disconnecting drive shafts.

CAUTION

If transmission is inoperable, or if final drive or track assembly is missing, the transmission oil pumps will not operate. Serious damage will occur inside the transmission. Do not tow carrier with drive shafts connected. Unit maintenance should disconnect drive shafts before towing carrier.

CAUTION

Carrier may be towed backwards a maximum of 1/4 mile at 5 mph or less when final drive to transmission drive shafts are connected. Damage to transmission will result if carrier is towed backwards faster than 5 mph or further than 1/4 mile.

NOTE

A small vehicle will not tow a larger one. Tow vehicle must be the same size or larger than disabled carrier.

Personnel will disembark disabled carrier before towing operation begins when using tow bar. When using tow cables, driver will remain with carrier during towing operations.

Two helpers, one at left front and one at left rear of recovery vehicle, act as road guides. Two other helpers install tow bar.

INSTALL TOW BAR ON DISABLED CARRIER AND RECOVERY VEHICLE

1. Align rear of recovery vehicle with front of disabled carrier.
2. Remove two retainer clips and pins from tow bar.
3. Connect tow bar to towing eyes of disabled carrier and secure with two pins and retainer clips.

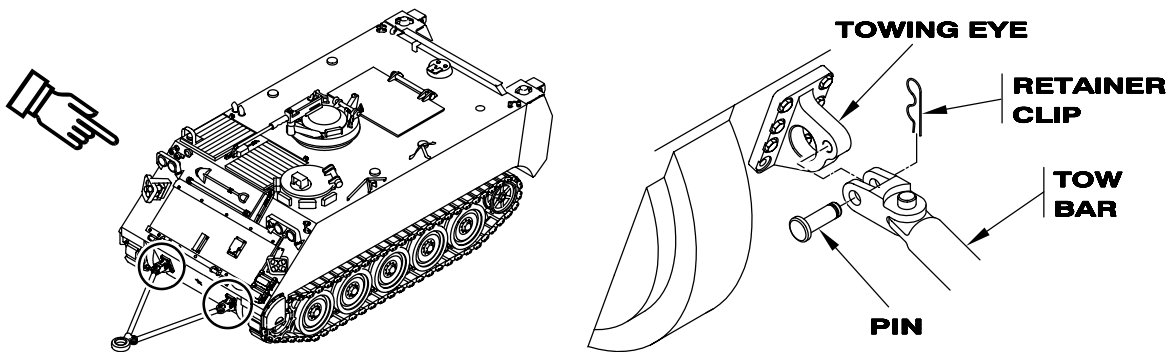

4. Remove cotter pin from tow pintle on recovery vehicle.
5. Pull up on pintle hook latch and open pintle.
6. □ Connect tow bar to tow pintle. □ Close tow pintle over tow bar. □ Check that tow pintle latch is closed.

7. Install cotter pin to secure pintle hook latch closed.

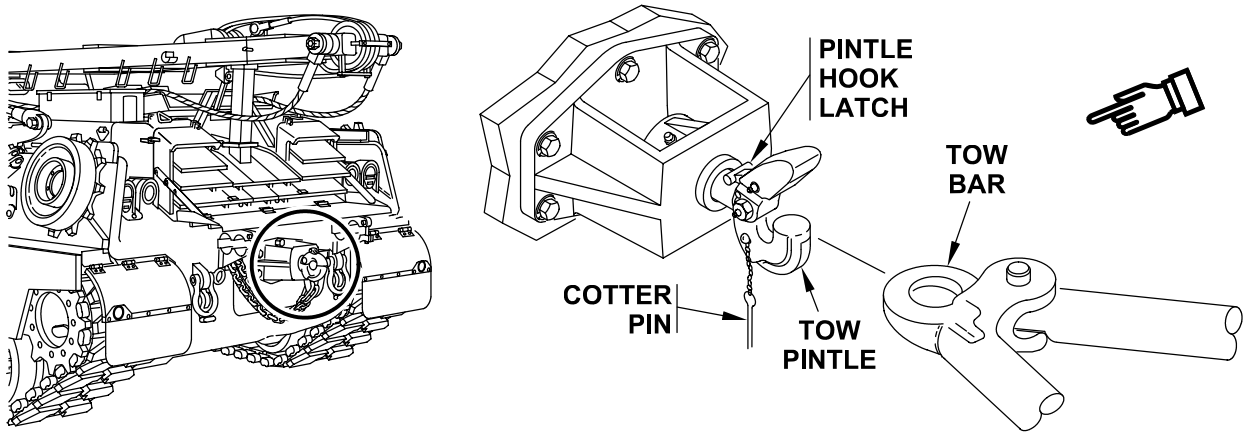

INSTALL TOW CABLES ON DISABLED CARRIER AND RECOVERY VEHICLE

NOTE

Left rear of recovery vehicle is connected to right front of disabled carrier. Right rear of recovery vehicle is connected to left front of disabled carrier.

1. Install two tow cables to tow hooks on front of disabled carrier and to tow hooks on rear of recovery vehicle in an X pattern.

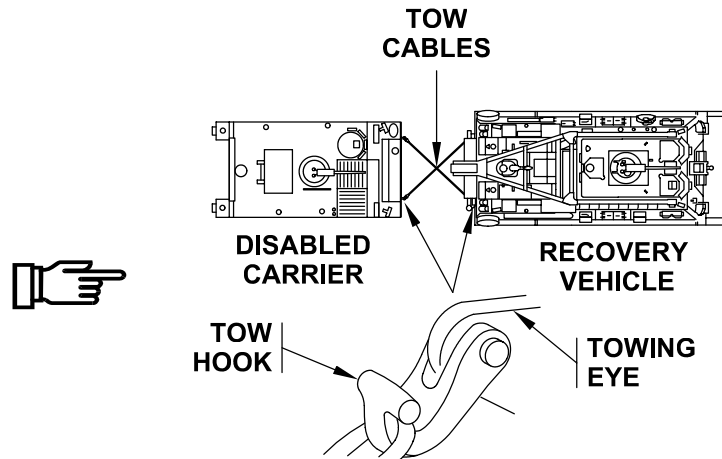

TOW DISABLED CARRIER

WARNING

Braking from high speeds when you tow with tow cables or tow bar can jackknife vehicles. Jackknife could injure personnel and damage vehicles. Do not tow at speeds over 15 mph (25 km/hr) with tow bar. Do not tow at speeds over 5 mph (8 km/hr) when in rough terrain, towing backward, or towing with tow cables.

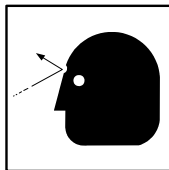
WARNING

Tow cables can snap and injure personnel. Close all hatch covers before you use tow cables to tow carrier. Clear personnel out of danger area.

1. If blocked, unblock carrier tracks (WP 0042 00).

2. Place transmission controller in disabled carrier to SL.

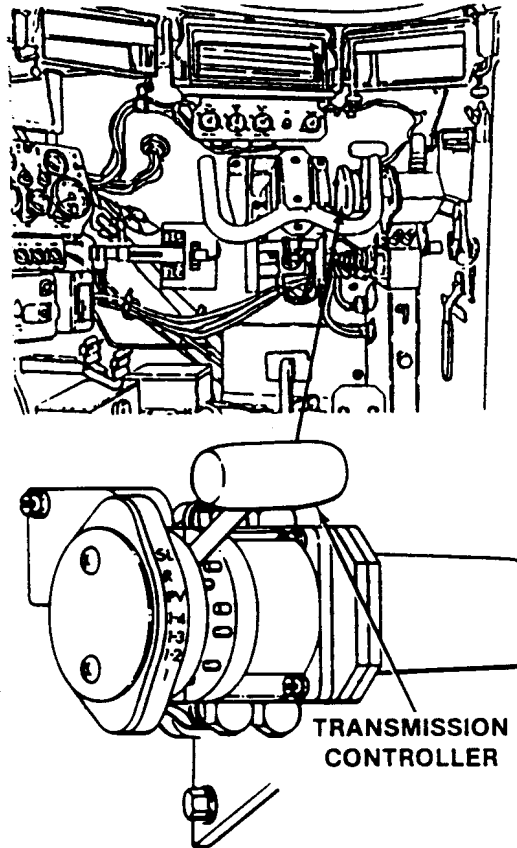

3. Release parking brake in disabled carrier (WP 0020 00).
4. Start engine in recovery vehicle.

NOTE

Constant speed must be maintained while towing carrier.

5. Drive recovery vehicle.
6. Slowly bring both vehicles to a stop by releasing accelerator pedal in recovery vehicle.
7. Set parking brake in disabled carrier (WP 0020 00).

REMOVE TOW BAR FROM DISABLED CARRIER AND RECOVERY VEHICLE

1. Stop engine on recovery vehicle.
2. Block disabled carrier.
3. Remove cotter pin from tow pintle on recovery vehicle.
4. Pull up on pintle hook latch and open pintle.
5. ~~Remove tow bar from tow pintle. Close tow pintle and check that tow pintle latch is closed.~~
6. Install cotter pin to secure pintle hook latch closed.

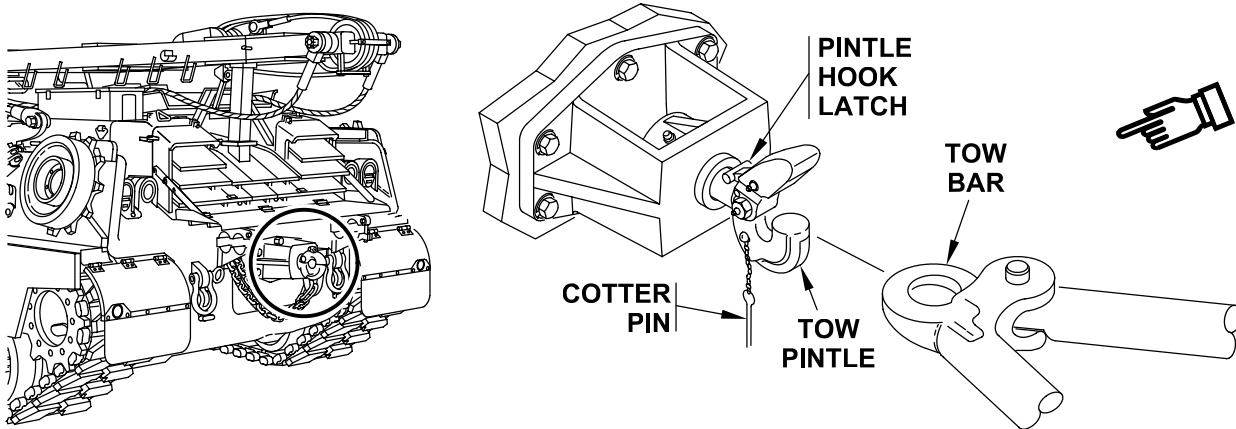

7. Remove two retainer clips and pins securing tow bar to towing eyes of disabled carrier. Remove tow bar.
8. Install two pins in tow bar and secure with retainer clips.

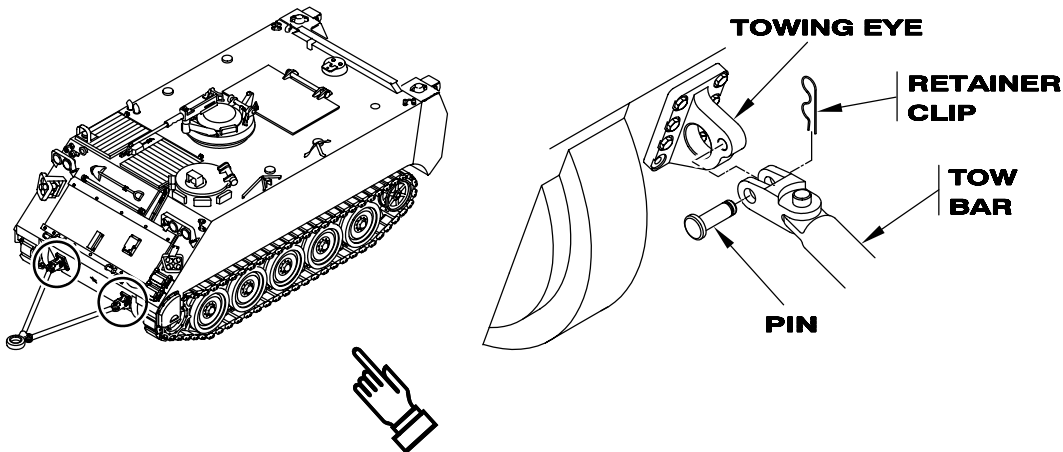

REMOVE TOW CABLES FROM DISABLED CARRIER AND RECOVERY VEHICLE

1. Drive recovery vehicle backward until tow cables are slack.
2. Stop engine on recovery vehicle.
3. Remove two tow cables from tow hooks on front of disabled carrier and from tow hooks on rear of recovery vehicle.

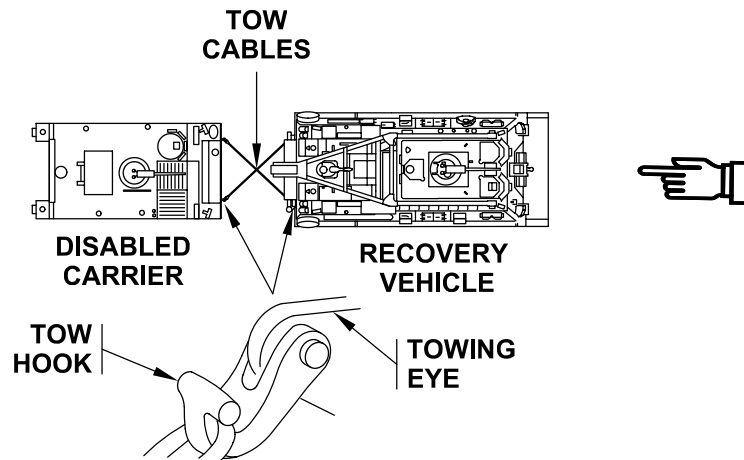
**END OF TASK**

TOW START DISABLED CARRIER

0078 00

THIS WORK PACKAGE COVERS:

- Install Tow Bar on Disabled Carrier and Recovery Vehicle (page 0078 00-1).
 - Install Tow Cables on Disabled Carrier and Recovery Vehicle (page 0078 00-4).
 - Tow Start Disabled Carrier (page 0078 00-4).
 - Remove Tow Bar From Disabled Carrier and Recovery Vehicle (page 0078 00-8).
 - Remove Tow Cables From Disabled Carrier and Recovery Vehicle (page 0078 00-9).
-

INITIAL SETUP:

Maintenance Level

Operator

Personnel Required

Driver (2)

Helper (H) (4)

Tools and Special Tools

Crowbar (WP 0102 00, Item 13)

Tow Cable (WP 0102 00, Item 7)

Recovery vehicle

Equipment Condition

Disabled carrier

WARNING



A towed carrier does not have steering until it reaches 3 mph plus. Personnel can be killed or injured. Use tow bar or two tow cables and use brakes to stop carrier, when necessary.

NOTE

The preferred method for tow starting a carrier is to use a tow bar. If tow bar is not available, you can use tow cables.

All personnel except driver will disembark disabled carrier before towing operation begins. Thoroughly inspect towing equipment before towing operation begins.

Two helpers, one at left front and one at left rear of recovery vehicle, act as road guides. Two other helpers install tow bar.

INSTALL TOW BAR ON DISABLED CARRIER AND RECOVERY VEHICLE

1. Align rear of recovery vehicle with front of disabled carrier.
2. Remove two retainer clips and pins from tow bar.

3. Connect tow bar to towing eyes of disabled carrier and secure with two pins and retainer clips.

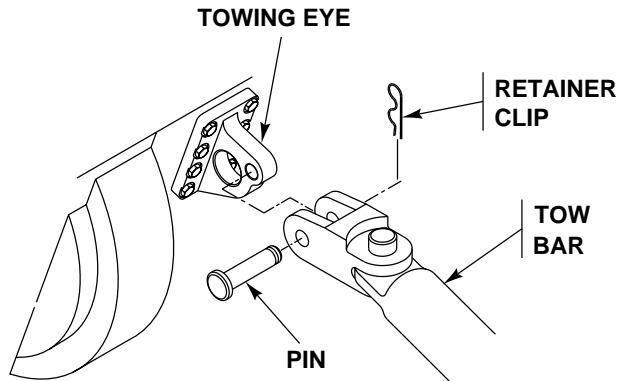
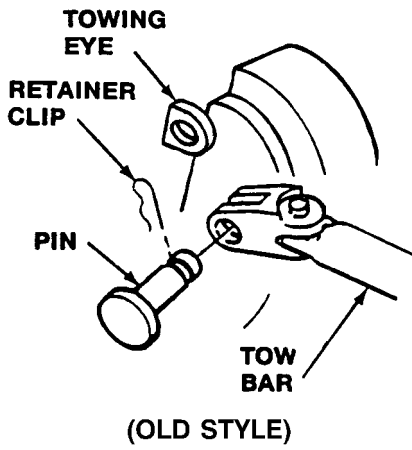
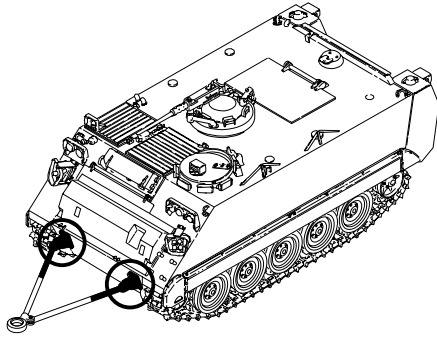

4. Remove cotter pin from tow pintle on recovery vehicle.
5. Pull up on pintle hook latch and open pintle.
6. Connect tow bar to tow pintle. Close tow pintle over tow bar. Check that tow pintle latch is closed.
7. Install cotter pin to secure pintle hook latch closed.

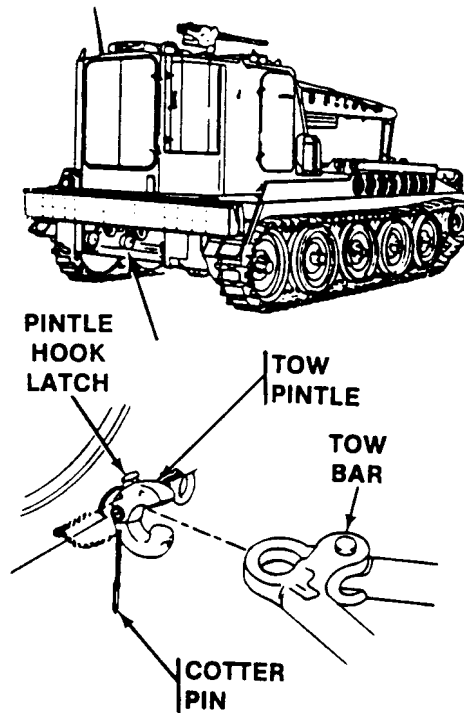

INSTALL TOW CABLES ON DISABLED CARRIER AND RECOVERY VEHICLE

NOTE

Left rear of recovery vehicle is connected to right front of disabled carrier. Right rear of recovery vehicle is connected to left front of disabled carrier.

1. Install two tow cables to tow hooks on front of disabled carrier and to tow hooks on rear of recovery vehicle in an x pattern.

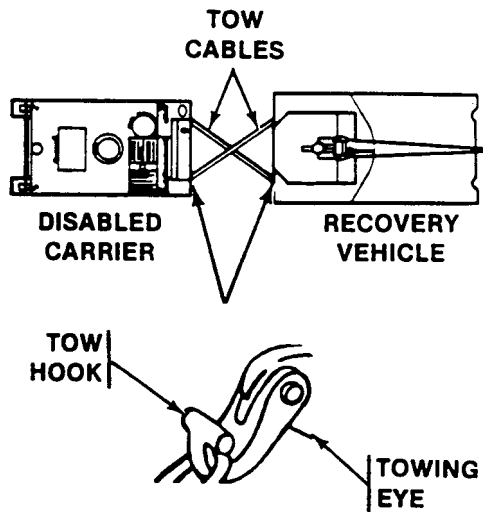

TOW START DISABLED CARRIER

1. Do Before (B) Preventive Maintenance Checks and Services on disabled carrier.

WARNING

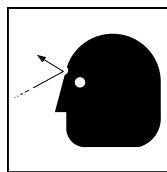

Tow cables can snap and injure personnel. Close all hatch covers before you use tow cables to tow carrier. Clear personnel out of danger area.

NOTE

If using tow bar, it is not necessary to close driver's hatch.

2. If using tow cables, close driver's hatch cover. See task: OPEN/CLOSE DRIVER'S HATCH COVER, WP 0006 00

- Place MASTER SWITCH in disabled carrier ON.

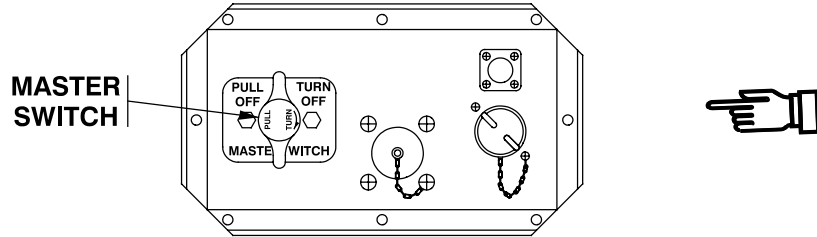

CAUTION

During engine start damage to radio components can occur. Make sure radio power switch is OFF before starting engine. See TM 11-5820-498-12.

- Push fuel cutoff control in all the way.

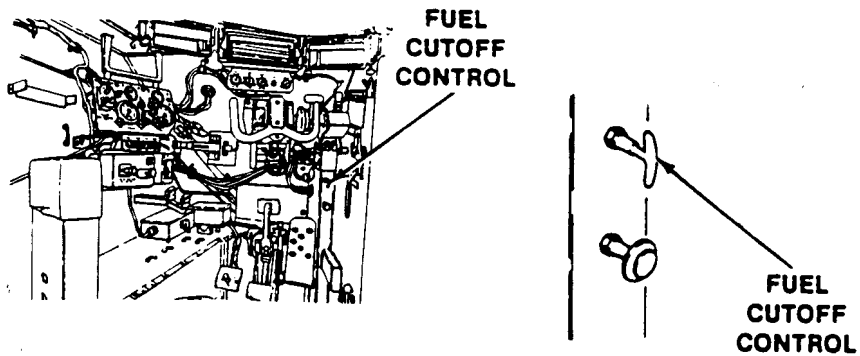

- Release parking brake. See task: SET/RELEASE PARKING BRAKE (WP 0020 00)

6. Place transmission controller in 1-4 range.

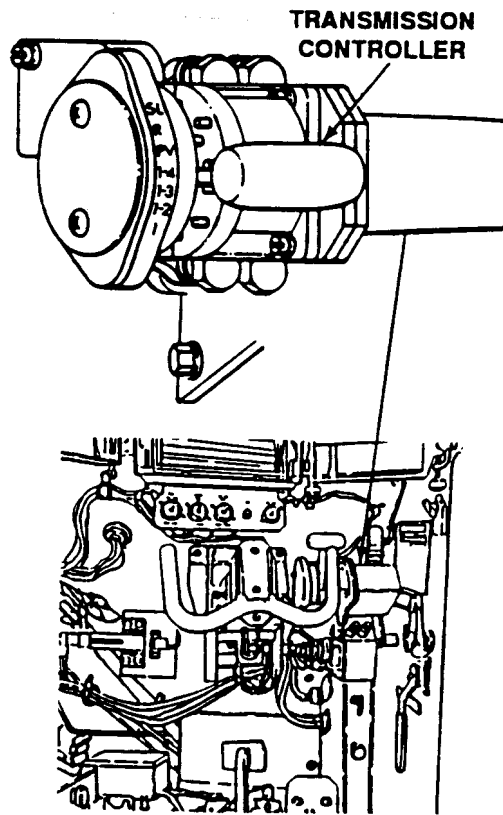

7. Start engine of recovery vehicle.

CAUTION

Failure to pull tow start handle when carrier begins to move could cause engine to start up in reverse and can damage carrier. Check that tow start handle is pulled out.

NOTE

If tow start handle is released during tow, it will return to normal position. No harm will result, but transmission will drop out of second gear lockup, and engine will not turn over.

8. Open cover, pull and hold tow start handle of disabled carrier. Signal driver of recovery vehicle to start.
9. Hold tow start handle while carrier is being towed. Find a straight level stretch of ground and tow disabled carrier at a speed between 9 and 15 mph to start the engine.
10. When disabled carrier starts, release tow start handle and close cover.

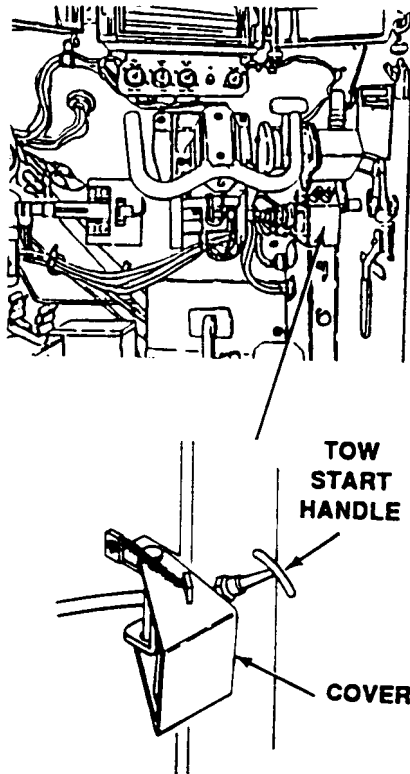

11. Slowly bring both vehicles to a stop.

12. Center steering wheel and place transmission controller in SL on disabled carrier.

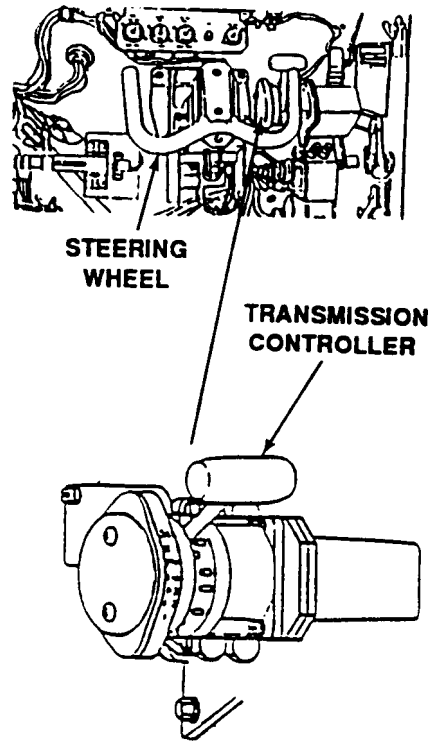

13. Set parking brake on disabled carrier. See task: SET/RELEASE PARKING BRAKE (WP 0020 00).

REMOVE TOW BAR FROM DISABLED CARRIER AND RECOVERY VEHICLE

1. Stop engine on recovery vehicle.
2. Remove cotter pin from tow pintle on recovery vehicle.
3. Pull up on pintle hook latch and open pintle.
4. Remove tow bar from tow pintle. Close tow pintle and check that tow pintle latch is closed.
5. Install cotter pin to secure pintle hook latch closed.

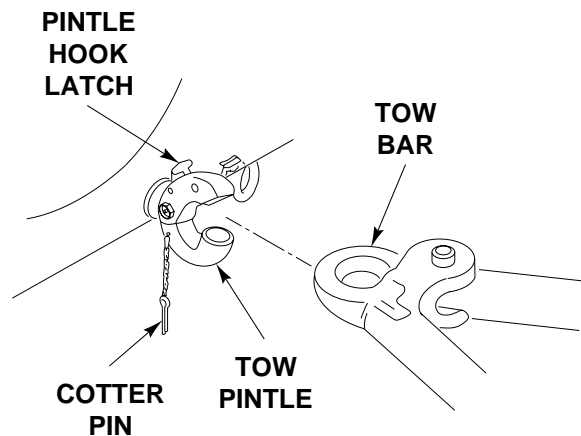

6. Remove two retainer clips and pins securing tow bar to towing eyes of disabled carrier. Remove tow bar.
7. Install two pins in tow bar and secure with retainer clips.

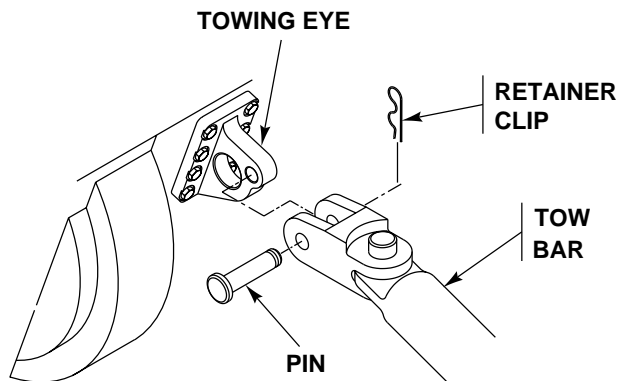
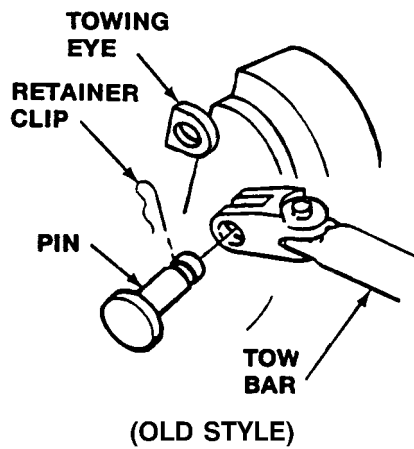
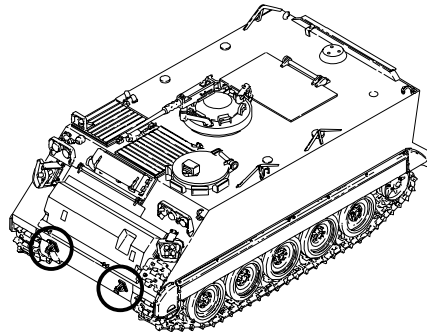

REMOVE TOW CABLES FROM DISABLED CARRIER AND RECOVERY VEHICLE

1. Drive recovery vehicle backward until tow cables are slack.
2. Stop engine on recovery vehicle.

3. Remove two tow cables from tow hooks on front of disabled carrier and from tow hooks on rear of recovery vehicle.

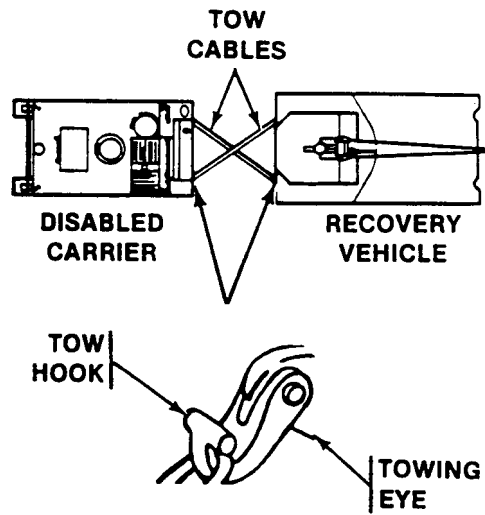

END OF TASK

TOWING TRAILER WITH CARRIER

0079 00

THIS WORK PACKAGE COVERS:

- Connect Trailer to Carrier (page 0079 00-1).
- Disconnect Trailer From Carrier (page 0079 00-5).

INITIAL SETUP:

Maintenance Level

Operator

Equipment Condition

Engine stopped (WP 0024 00)

Personnel Required

Driver

Tools and Special Tools

Chain assembly (4010-01-447-0753)

NOTE

Use suitable trailer only when mission requires one.

CONNECT TRAILER TO CARRIER

CAUTION

Carrier ramp could be damaged. Maximum weight of towed load is 14,500 pounds (6,583 kg).

1. Position trailer so its tow bar lines up with tow pintle on carrier.

NOTE

If vehicle has tow extender, perform Step 2 below. Otherwise, skip to Step 3.

2. Unstow pintle extender. Unlock linchpin and remove hitch pin to free extension bracket. Swing up 90 degrees to towing position. Reinstall hitch pin and lock with linchpin.

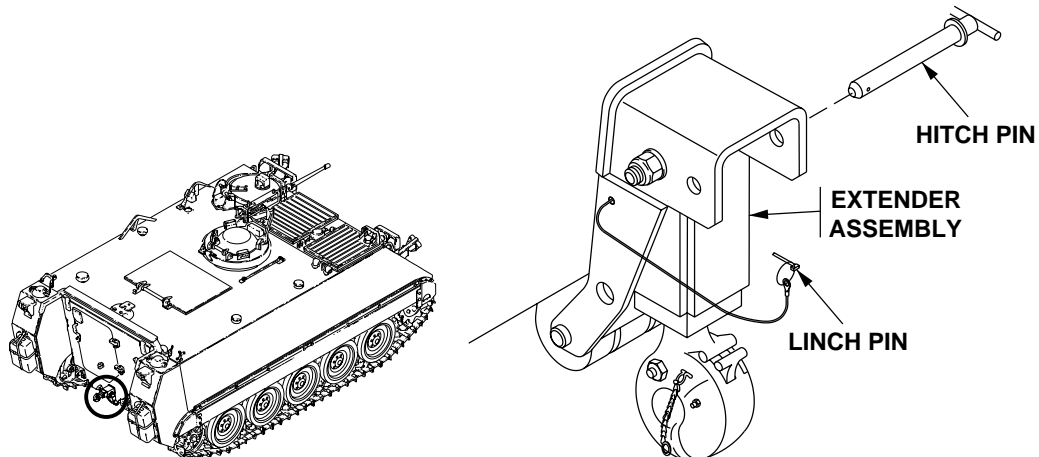

3. Remove cotter pin. Pull up on pintle hook latch and open pintle.
4. Hook trailer tow bar on carrier tow pintle.
5. Close tow pintle over trailer tow bar. Check that pintle latches closed. Install cotter pin to secure latch closed.

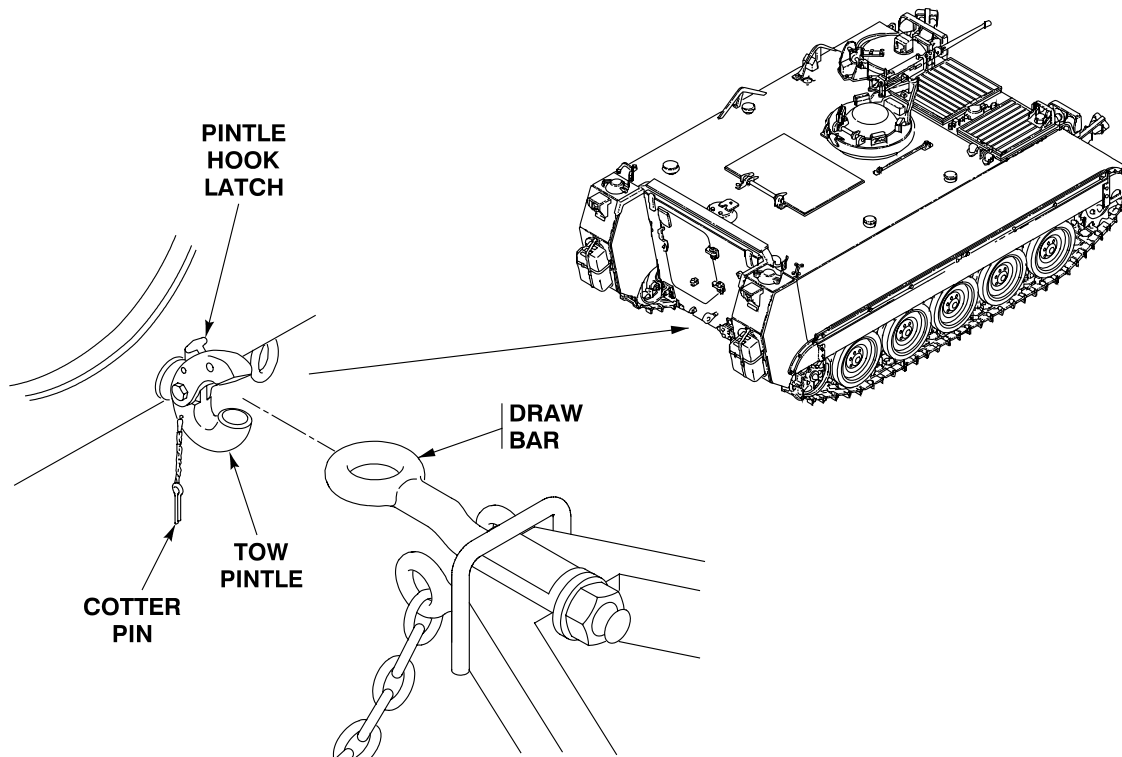

6. Remove existing towing chains.
7. Remove two shackles from tool bag and install them on towing eyes.
8. Use towing chains from M200 series trailer.
9. Attach new chains to trailer and to shackles on towing eyes in an X pattern.

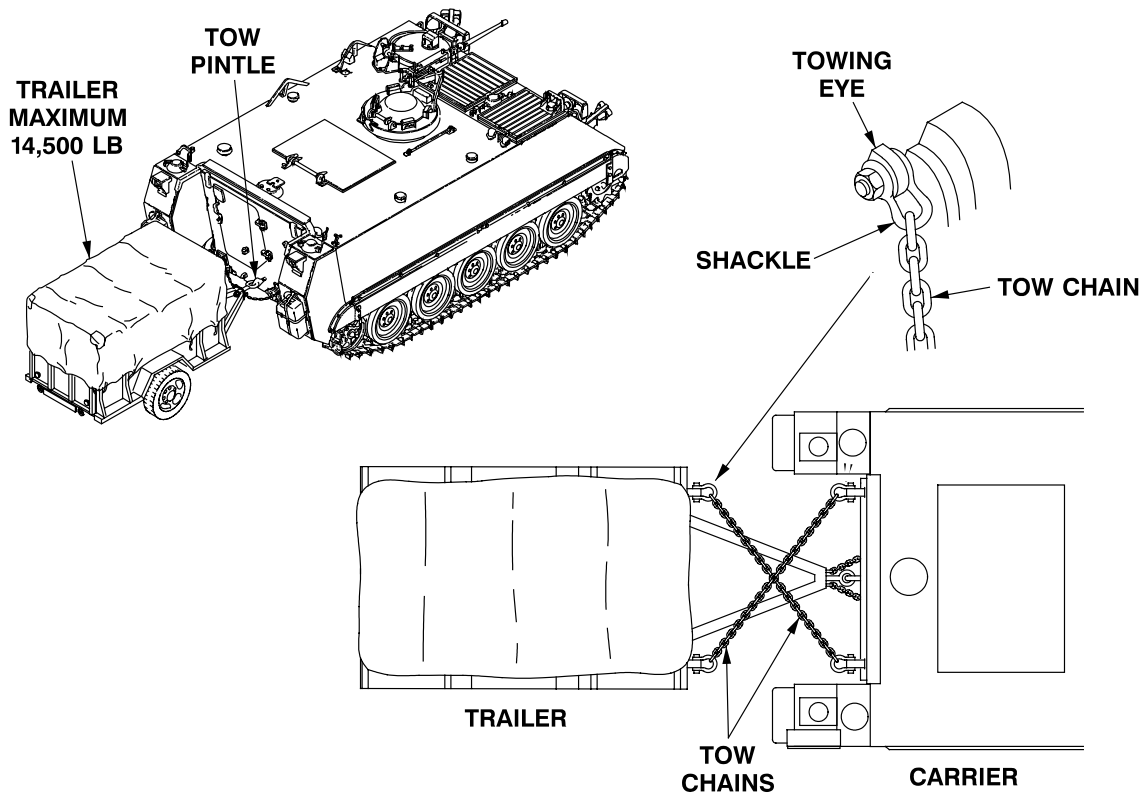

10. If trailer has an electrical connector, plug connector into carrier's trailer light receptacle. This will allow trailer's tail light and stop light to work with carrier lights.

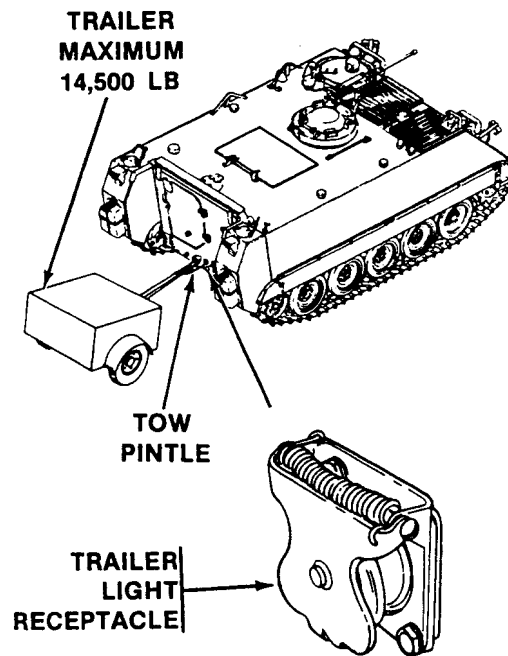

CAUTION

You will damage trailer or carrier if you pivot or make sharp turns at any speed when towing a trailer. (Use trailer only when mission requires one.) Use caution when making turns.

11. START ENGINE (WP 0021 00).
12. DRIVE CARRIER (WP 0023 00).

DISCONNECT TRAILER FROM CARRIER

1. STOP ENGINE. See WP 0024 00.
2. If connected, unplug trailer electrical connector from carrier trailer light receptacle.
3. Remove tow chains from shackles.
4. Remove shackles from towing eyes and stow in tool bag.
5. Remove chains from trailer and return to M200 series trailer.
6. Install trailer's original tow chains.
7. Remove cotter pin. Pull up on pintle hook latch and open pintle.
8. Remove trailer draw bar from carrier tow pintle.
9. Close tow pintle. Check that tow pintle latches closed. Install cotter pin to secure latch.

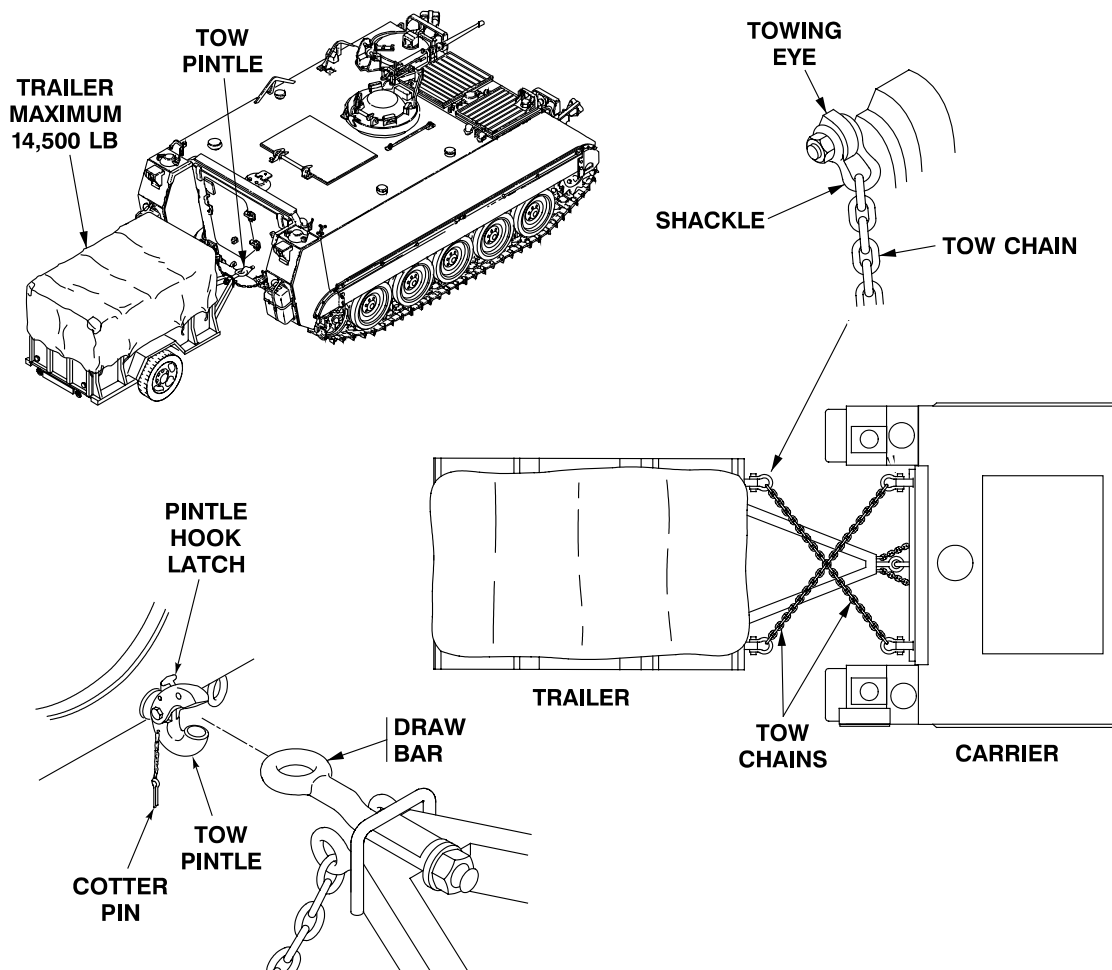

10. Stow pintle extender. Unlock linchpin and remove t-handle pin and allow extender bracket to swing down 90 degrees. Reinstall t-handle pin and lock with linchpin to secure bracket in down position.

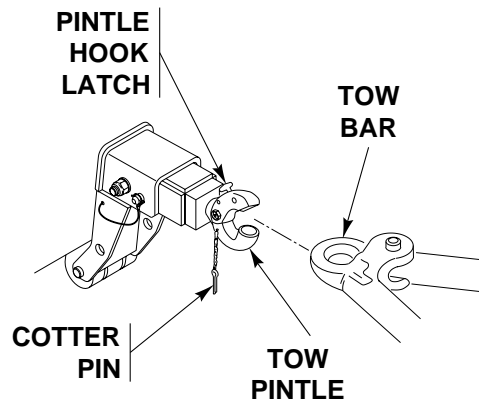

END OF TASK

OPERATE NBC KIT

0080 00

THIS WORK PACKAGE COVERS:

- Turn NBC Kit On In Ambulance With Litter Kit (page 0080 00-1).
- Turn NBC Kit Off In Ambulance With Litter Kit (page 0080 00-3).
- Turn NBC Kit On In Carrier Without Litter Kit (page 0080 00-4).
- Turn NBC Kit Off In Carrier Without Litter Kit (page 0080 00-6).

INITIAL SETUP:

Maintenance Level

Operator

References

TM 3-4240-346-10

Personnel Required

Soldier

Equipment Condition

NBC Kit installed

TURN NBC KIT ON IN AMBULANCE WITH LITTER KIT

WARNING

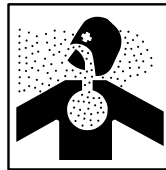

Filters and masks of the NBC system will not protect you against carbon monoxide, ammonia, acid, or solvent fumes. Be sure the carrier is properly ventilated. Do not let any filters of the NBC system get wet. Water will destroy their ability to take the deadly chemical and biological agents out of the air. Contaminated filters must be handled using adequate precautions and must be disposed of by trained personnel. If it is very cold outside, there is danger of frostbitten lungs from inhaling the cold air. Do not connect the hoses to your M42 mask canister until NBC system has been operating at least 15 minutes with the heater turned on.

1. Remove spring clip from air intake openings on air purifier.

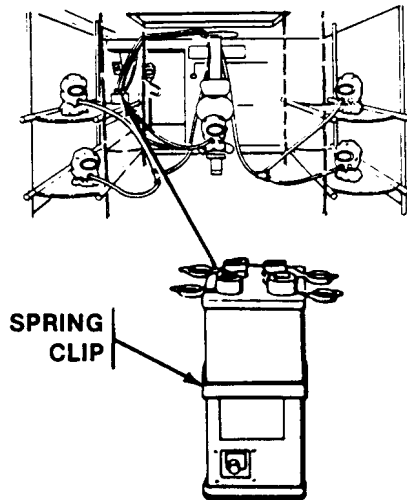

NOTE

Air purifier switches are located near the driver's seat and in the rear compartment.

2. Turn air purifier switches ON.

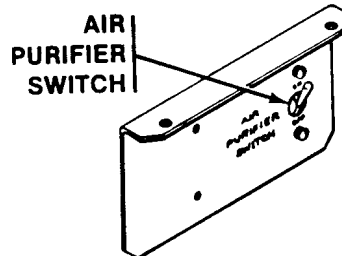

3. Assist patients in putting on their hospital hoods. Adjust the mask, tie the strap, and attach hoses to inlet adapter on hood.

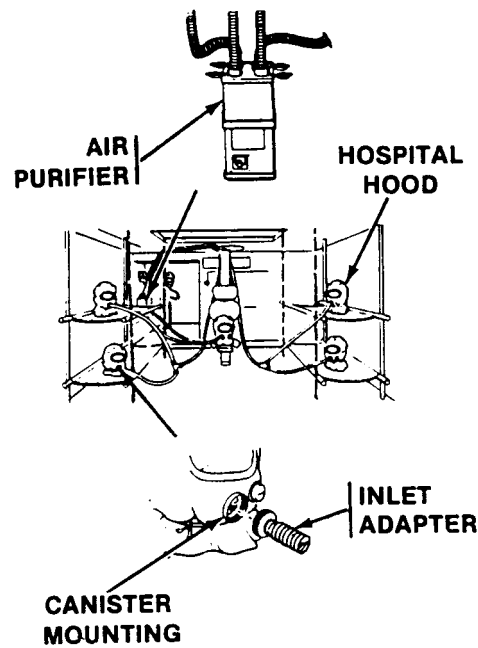

4. Make sure each patient is supplied with air.

NOTE

Attach a hospital hood, with its bottom folded, to any open hose to prevent too much air loss.

5. If only three outlets are used, cover the fourth with a solid cap. When less than three are used, cover one of the unused outlets with a solid cap and the other with a cap with a hole.

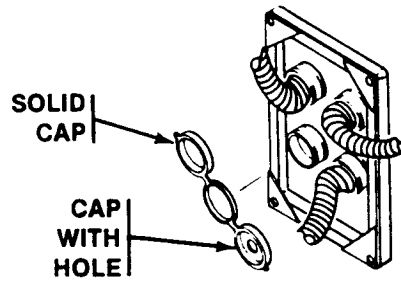

TURN NBC KIT OFF IN AMBULANCE WITH LITTER KIT

1. Help the patients to remove their hospital hoods. Uncouple the hoses from the inlet adapters on the hoods.
2. Turn the air purifier switches OFF.

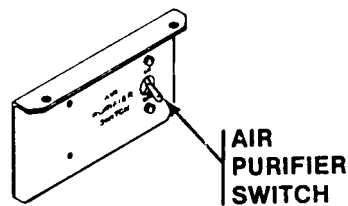

3. Stow hoses connected to Y connectors out of the way.
4. Install spring clip over air intake openings on the air purifier.

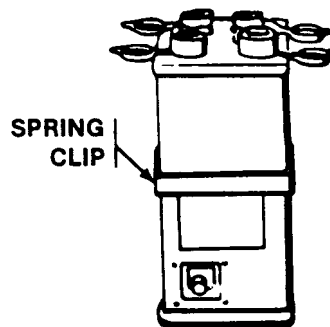

5. Clean air purifier housing with a clean cloth as soon as possible after operation.

TURN NBC KIT ON IN CARRIER WITHOUT LITTER KIT

WARNING

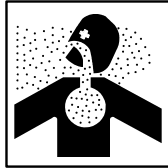

Filters and masks of the NBC system will not protect you against carbon monoxide, ammonia, acid, or solvent fumes. Be sure the carrier is properly ventilated. Do not let any filters of the NBC system get wet. Water will destroy their ability to take the deadly chemical and biological agents out of the air. Contaminated filters must be handled using adequate precautions and must be disposed of by trained personnel. If it is very cold outside, there is danger of frostbitten lungs from inhaling the cold air. Do not connect the hoses to your M42 mask canister until NBC system has been operating at least 15 minutes with the heater turned on.

NOTE

For operation of M42 protective mask, refer to TM 3-4240-346-10.

1. All crew members must put on their M42 protective mask. Adjust the mask.



2. Remove spring clip from air intake openings on air purifier.
3. Turn on heater to warm air coming into M42 mask by turning knob clockwise from OFF until light comes ON.

NOTE

Light may go on and off by itself during operation. This is normal; the light is lit only when heating element is on.

4. Adjust to desired warmth by turning knob clockwise to increase heat and counterclockwise to decrease heat.

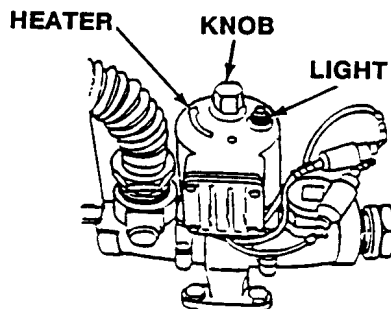

WARNING

If it is very cold outside, there is danger of frostbitten lungs from inhaling cold air. Do not connect the hoses to your M42 mask canister until heater has run for at least 15 minutes.

5. Disconnect hose from orifice connector at your duty station.
6. Connect canister coupling to hose.
7. When through with NBC system, disconnect canister coupling from hose and connect hose to orifice connector.

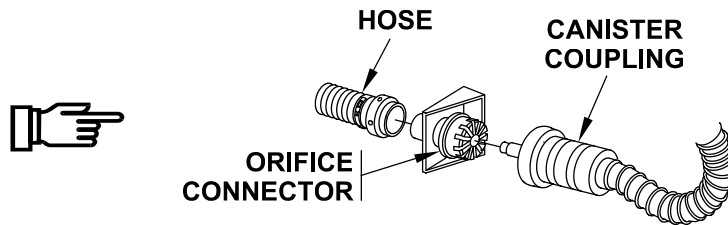

8. Turn off heater by turning knob counterclockwise to OFF.

NOTE

Light should extinguish. If not, notify unit maintenance.

9. Turn blower off by setting NBC power switch to OFF.
10. Slide spring clip over air intake holes on precleaner and particulate filter assembly.

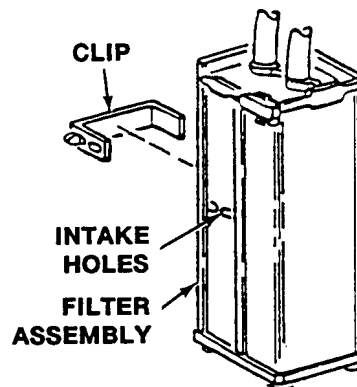

NOTE

Air purifier switches are located near the driver's seat and in the rear compartment.

11. Turn air purifier switches ON.

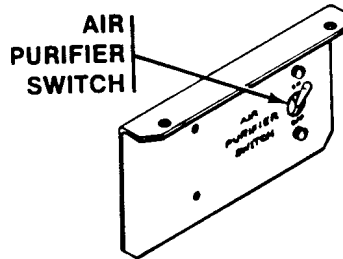

12. Couple the hoses leading from the air purifier to the canisters of the M42 protective mask.

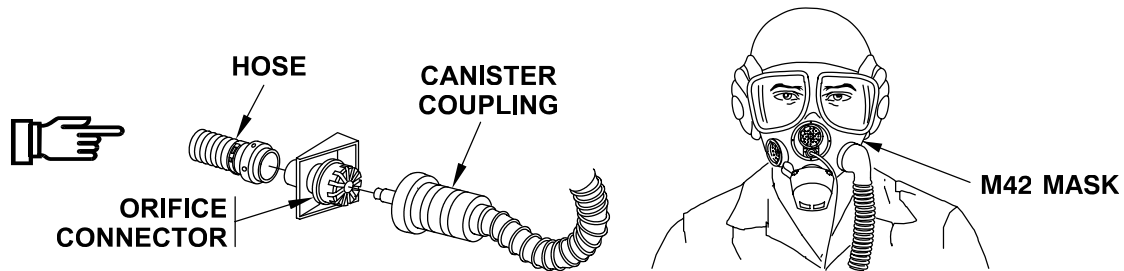

13. If only three outlets are used, cover the fourth with a solid cap. When less than three outlets are used, cover one of the unused outlets with a solid cap and the other with a cap with a hole.

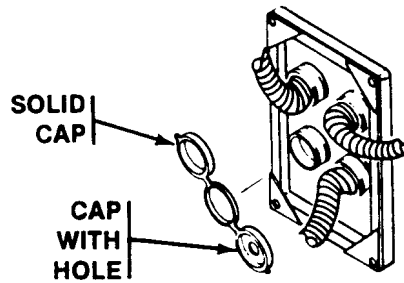

TURN NBC KIT OFF IN CARRIER WITHOUT LITTER KIT

1. Uncouple hoses from the mask canisters.
2. Turn the air purifier switches OFF.

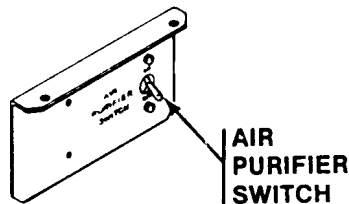

3. Remove and stow mask and hoses.

4. Install spring clip over air intake openings on the air purifier.

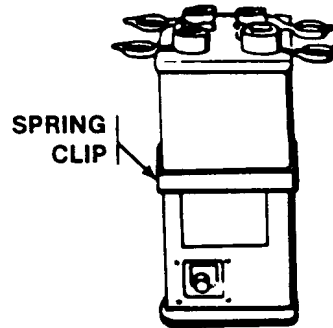

5. Clean air purifier housing with a clean cloth as soon as possible after operation.

END OF TASK

OPERATE NBC SYSTEM

0081 00

THIS WORK PACKAGE COVERS:

Operate NBC System (page 0081 00-1).

INITIAL SETUP:

Maintenance Level

Operator

References

TM 3-4240-346-10

Personnel Required

Soldier

Equipment Condition

NBC systems installed

Operate NBC System

WARNING

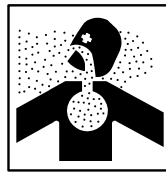

Filters and masks of the NBC system will not protect you against carbon monoxide, ammonia, acid, or solvent fumes. Be sure the vehicle is properly ventilated. Do not let any filters of the NBC system get wet. Water will destroy their ability to take the deadly chemical and biological agents out of the air. Contaminated filters must be handled using adequate precautions and must be disposed of by trained personnel. If it is very cold outside, there is danger of frostbitten lungs from inhaling the cold air. Do not connect the hoses to your M42 mask canister until NBC system has been operating at least 15 minutes with the heater turned on.

1. Put on M42 mask.



NOTE

For operation of the M42 mask, refer to TM 3-4240-346-10.

NOTE

Loosen two frame assembly clamps on air purifier assembly to open or close the spring clip.
Tighten frame assembly clamps immediately when done.

- Slide spring clip away from air intake holes on air purifier assembly.

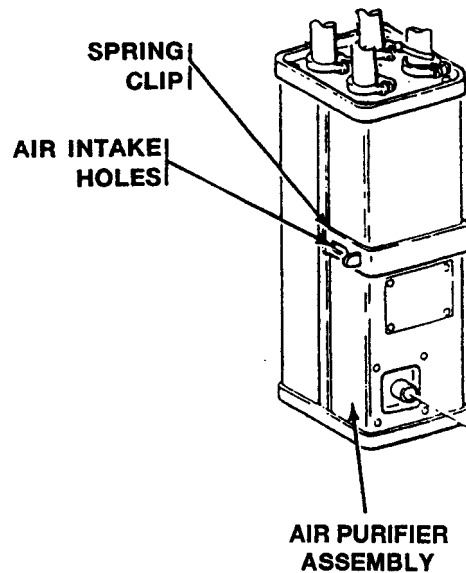

- Turn blower on by setting NBC POWER switch to ON.

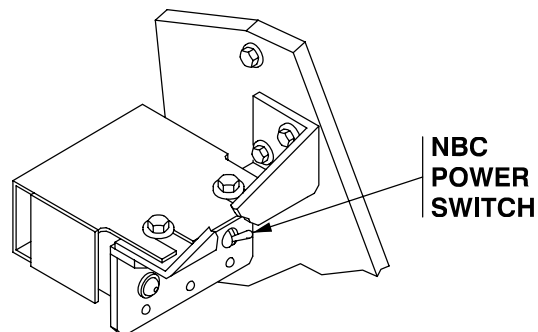

WARNING

If it is very cold outside, there is danger of frost bitten lungs from inhaling the cold air. Do not connect the hoses to your M42 mask canister until heater has run for at least 15 minutes. Follow the cold weather operating procedures.

4. Disconnect hose from orifice connector at your duty station.

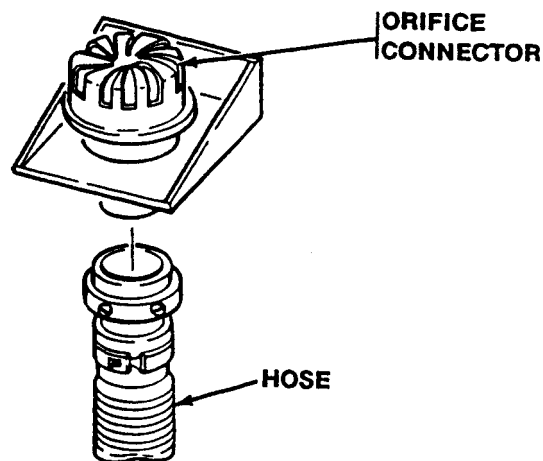

5. Connect canister coupling to hose.



- When through with NBC system, disconnect hose from mask and connect hose to orifice connector. Replace loose hose around bracket or on M113A3 secure with straps.

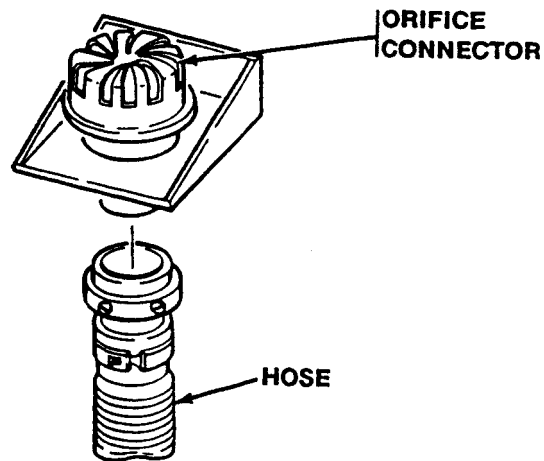

- Turn blower off by setting air purifier NBC POWER switch to OFF.

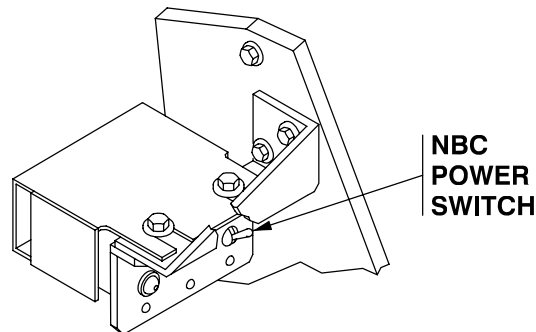

NOTE

**Loosen two frame assembly clamps on air purifier assembly to open or close the spring clip.
Tighten frame assembly clamps immediately when done.**

8. Slide spring clip over air intake holes on air purifier filter assembly.

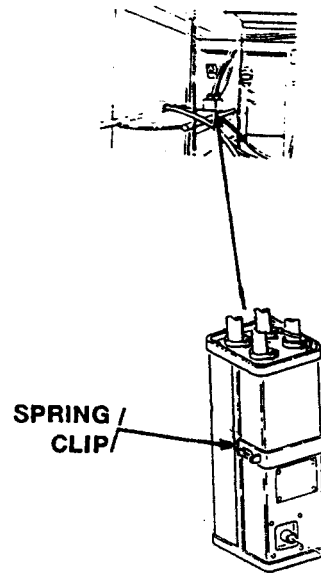

END OF TASK

OPERATE SMOKE GRENADE LAUNCHERS (ALL EXCEPT M577A3, M1064A3, AND M1068A3)

0082 00

THIS WORK PACKAGE COVERS:

- Loading Smoke Grenade Launchers (page 0082 00-1).
- Launching Smoke Grenades (page 0082 00-6).
- Misfires (page 0082 00-9).
- Duds (page 0082 00-10).
- Unloading Smoke Grenade Launchers (page 0082 00-10).

INITIAL SETUP:

Maintenance Level

Operator

Equipment Condition

Carrier parked

Personnel Required

Commander

LOADING SMOKE GRENADE LAUNCHERS

1. Turn MASTER SWITCH OFF.

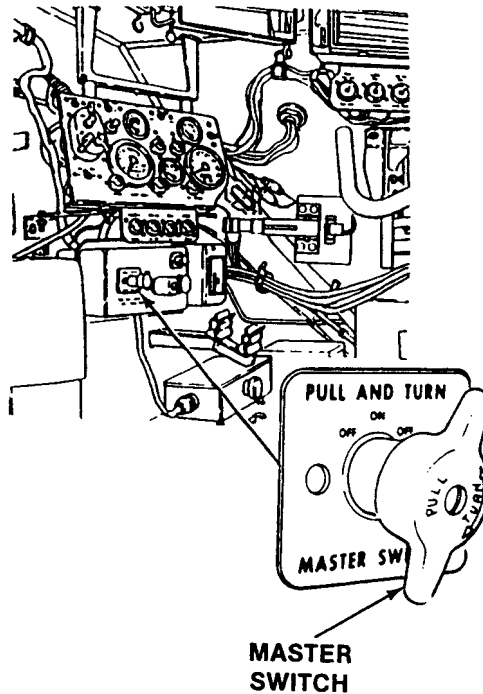

OPERATE SMOKE GRENADE LAUNCHERS (ALL EXCEPT M577A3, M1064A3, AND M1068A3) — Continued

0082 00

2. Place ARM/OFF switch to OFF. Check that indicator light is off.

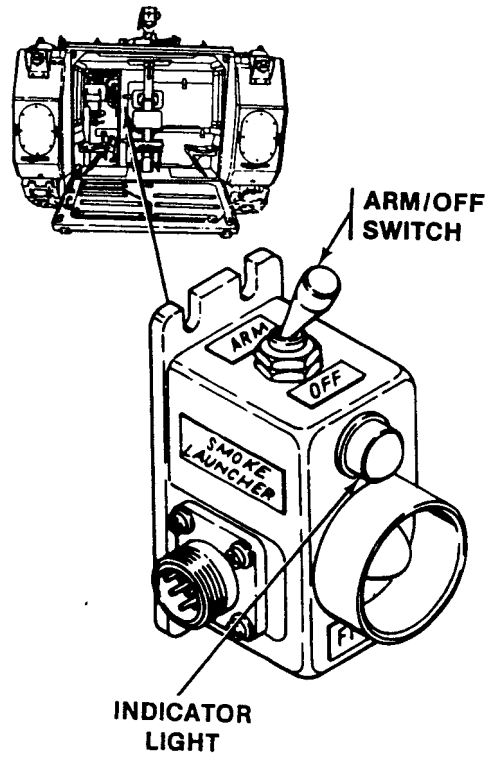

OPERATE SMOKE GRENADE LAUNCHERS (ALL EXCEPT M577A3, M1064A3, AND M1068A3) — Continued

0082 00

3. Remove rubber covers from launcher tubes and check that tubes are free of damage and debris. Retain rubber covers.

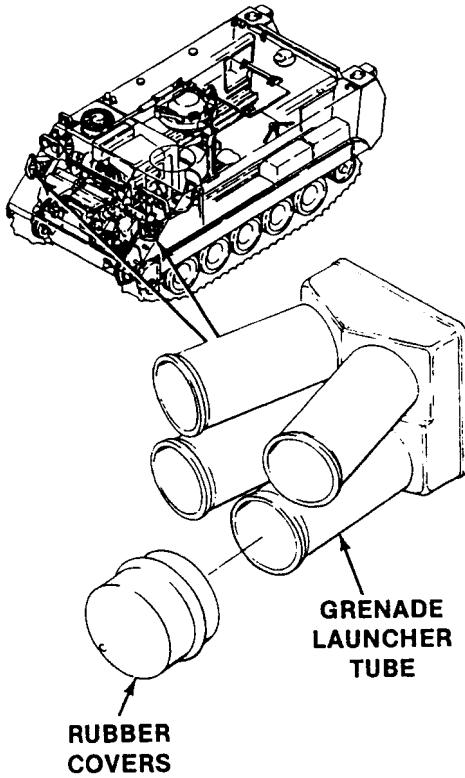

WARNING

Smoke grenades can explode and kill or injure personnel. Handle grenades with care. Do not drop or throw grenades. Do not use damaged grenades. Keep grenades away from electric sparks. Keep containers sealed until you are ready to use grenades.

WARNING

Heat could set off smoke grenades and kill or injure personnel. Do not place smoke grenades on hot surfaces.

4. Remove and unpack eight smoke grenades from ammo box.

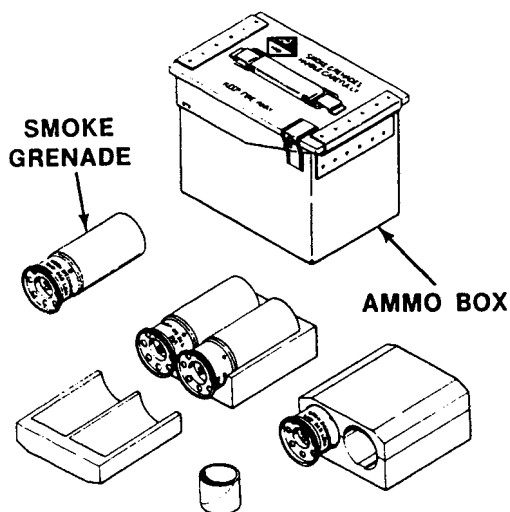

WARNING

Electrical trouble could cause smoke grenades to launch and kill or injure personnel. Make sure ARM/OFF switch is OFF before you load smoke grenades. Do not place any part of your body in front of smoke grenade launchers.

CAUTION

Smoke grenades can fail to fire. Keep grenades free of dirt and grease. Do not let firing contacts be damaged.

5. Grip top of grenade and insert grenade into launcher tube with metal end down. With palm of hand, gently push grenade down into launcher tube so that spring clip at base of grenade engages tip plug at bottom of tube.

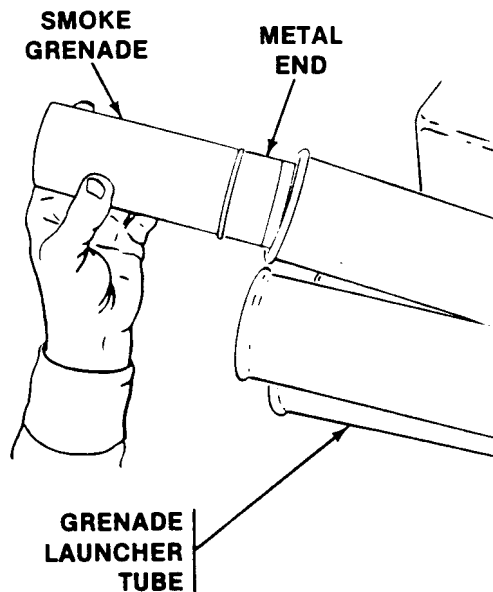

6. Rotate grenade 1/2 turn to insure good electrical contact.

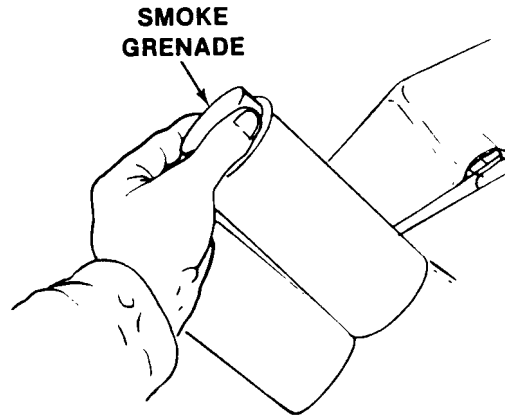

LAUNCHING SMOKE GRENADES

WARNING



Smoke grenades explode and burn. Handle them with care. Except when using your hand to load grenade launcher, never put any part of your body in front of loaded launcher tubes. You could be killed or injured. Check that personnel are clear of firing lines when launching grenades.

1. Close driver's hatch cover. See task: OPEN/CLOSE DRIVER'S HATCH COVER (WP 0006 00).
2. Close commander's hatch cover. See task: OPEN/CLOSE COMMANDER'S HATCH COVER (WP 0009 00).
3. Close cargo hatch cover. See task: OPEN/CLOSE CARGO HATCH COVER (WP 0008 00).
4. Point front of carrier directly at area where smoke is desired to conceal the maneuver of the carrier from enemy observation.

NOTE

Before launching grenades, make sure there are no obstacles directly in front of carrier.

5. Turn MASTER SWITCH ON.

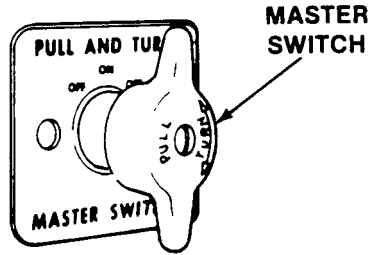

6. Place ARM/OFF switch to ARM. Check that indicator light comes on.

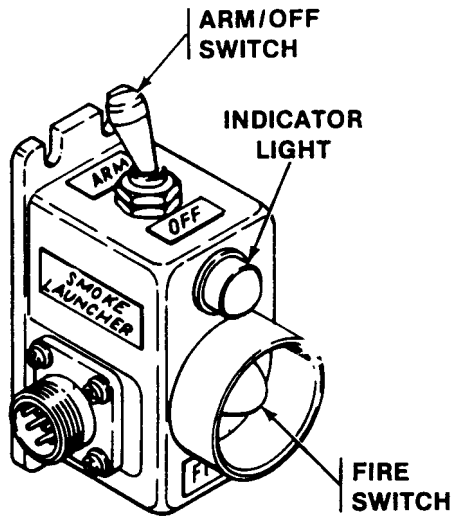

NOTE

When fire switch is pressed, eight grenades will detonate around a 105 degree arc, 98 feet (30 meters) from carrier. The smoke cloud will be approximately 30 feet (9 meters) high and will last about 1 to 3 minutes, depending on wind conditions.

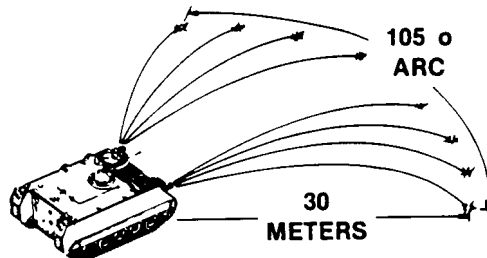

7. Press FIRE switch to launch smoke grenades.

8. Place ARM/OFF switch to OFF. Check that indicator light goes off.

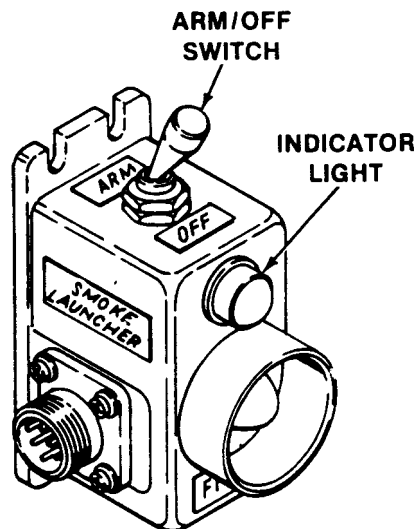

9. As soon as tactical situation permits, check that all eight smoke grenades have been launched. If any of the smoke grenades did not fire, see below for procedure on MISFIRES.

NOTE

Smoke grenade launchers must be cleaned and inspected daily when smoke grenades have been launched. Notify unit maintenance.

10. If all smoke grenades have fired, reload smoke grenade launchers as required by mission. Do Step 1, Step 2, and Steps 4 - 6 of procedure on LOADING SMOKE GRENADE LAUNCHERS.

MISFIRES

WARNING

If misfired smoke grenades launch during unloading, personnel in the area could be killed or injured. Keep carrier pointed down range until grenades are removed.

NOTE

A misfire is the failure of a smoke grenade to launch from grenade launcher tube.

1. Place ARM/OFF switch to ARM and press FIRE switch.

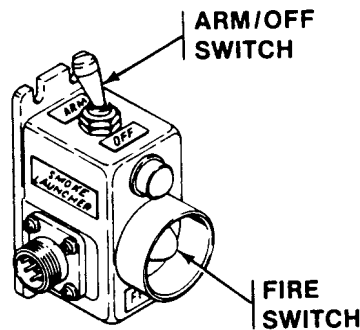

2. If grenade does not fire, place ARM/OFF switch OFF. Check that grenade is firmly seated in launcher tube.

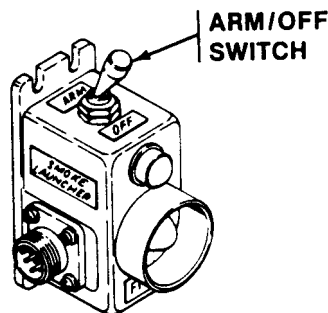

3. Place ARM/OFF switch to ARM and press FIRE switch.
4. If grenade does not fire, attempt to fire grenade from another launcher tube. If grenade fires, notify unit maintenance of defective launcher tube.
5. If grenade still does not fire, treat as a DUD. See following procedure.

DUDS



Misfired smoke grenades could kill or injure personnel if mishandled. Do not attempt to move a dud grenade.

1. In a training situation when a grenade fails to ignite after being launched, wait 15 minutes; then notify Explosive Ordnance Disposal (EOD) personnel. Give type, quantity and precise location of dud.

UNLOADING SMOKE GRENADE LAUNCHERS



Electrical trouble could cause smoke grenades to launch and kill or injure personnel. Make sure ARM/OFF switch is OFF before unloading smoke grenades. Do not place any part of your body in front of smoke grenade launchers.



Heat could set off smoke grenades and kill or injure personnel. Do not place smoke grenades on hot surfaces.

1. Place ARM/OFF switch to OFF.

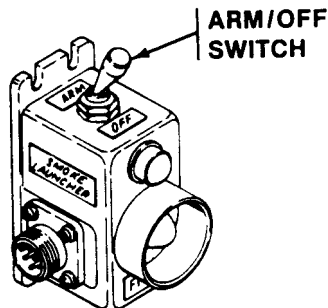

OPERATE SMOKE GRENADE LAUNCHERS (ALL EXCEPT M577A3, M1064A3, AND M1068A3) — Continued

0082 00

2. Turn MASTER SWITCH OFF.

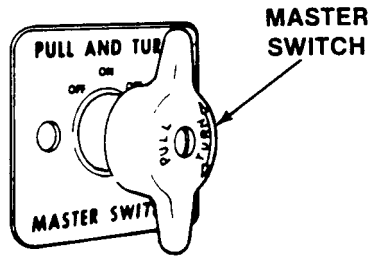

3. Remove smoke grenades from launcher tubes and place in ammo box.

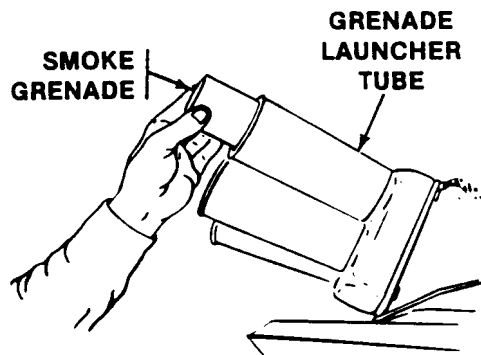

4. Install rubber covers on launcher tubes.

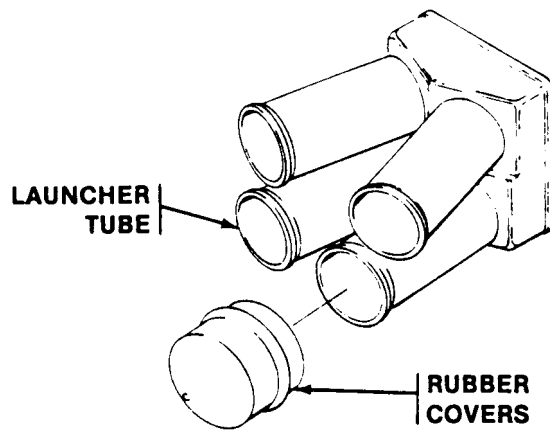

5. Secure grenades in accordance with unit SOP.

END OF TASK

COVER/UNCOVER INTAKE AND EXHAUST GRILLES

0083 00

THIS WORK PACKAGE COVERS:

- Cover Exhaust Grille (page 0083 00-2).
- Cover Intake Grille (page 0083 00-3).
- Uncover Exhaust Grille (page 0083 00-4).
- Uncover Intake Grille (page 0083 00-5).

INITIAL SETUP:

Maintenance Level

Operator

Equipment Condition

Engine stopped

Personnel Required

Driver

CAUTION

Extended operation with intake and exhaust grilles covered can cause engine to overheat and be damaged. Uncover exhaust grille and open one or more flaps on intake grille before starting engine. Avoid extended operation with intake grille covered.

NOTE

Intake and exhaust grille covers prevent ice, snow and other debris from entering power plant compartment and exhaust well when carrier is not in use.

When not in use, intake and exhaust grille covers are rolled up and secured to area between intake and exhaust grilles.

COVER EXHAUST GRILLE

1. Release two straps and unroll exhaust grille cover over exhaust grille.

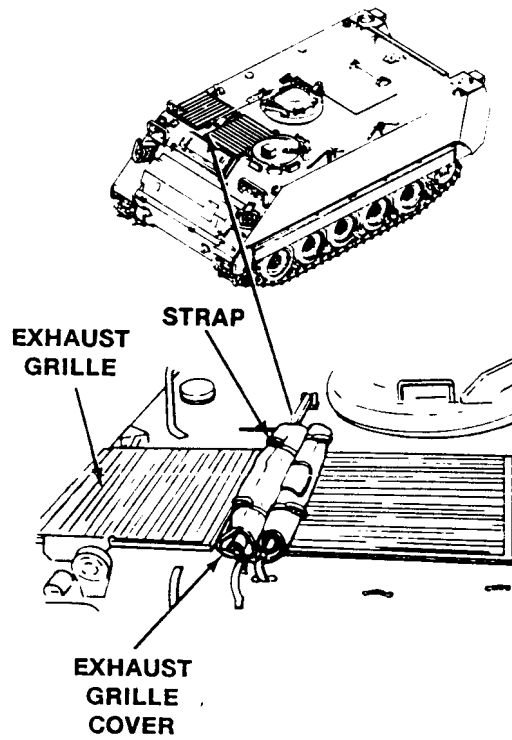

2. Secure two straps to footman loops on right side of exhaust grille.

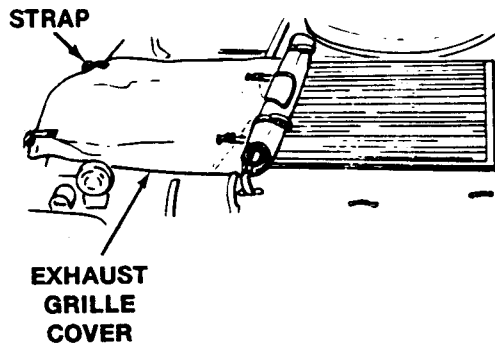

COVER INTAKE GRILLE

1. Release two straps and unroll intake grille cover over intake grille.

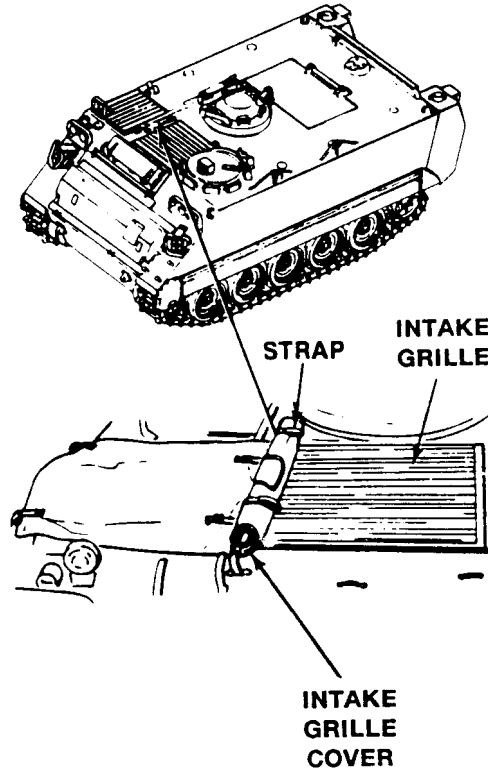

2. Secure two straps to footman loops on left side of intake grille.

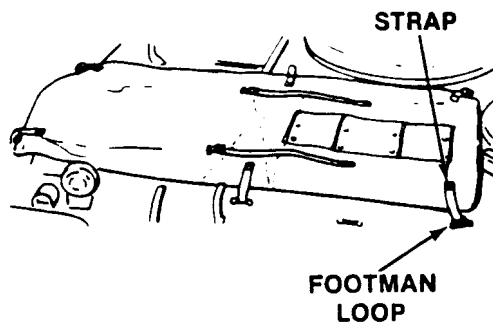

3. To open one or more flaps on intake grille cover, release stud fasteners and fold flap open. Secure flap open with stud fasteners.

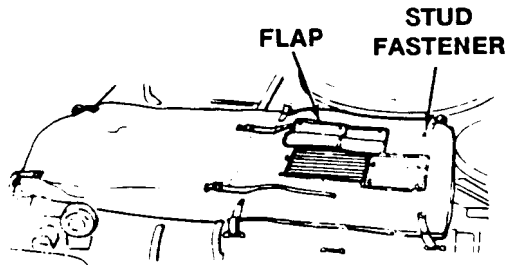

UNCOVER EXHAUST GRILLE

1. Release two straps from footman loops on right side of exhaust grille.

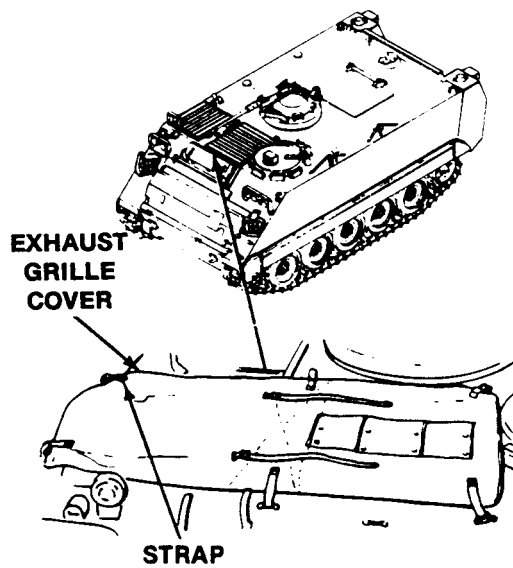

2. Roll exhaust grille cover toward area between intake and exhaust grilles and secure with two straps.

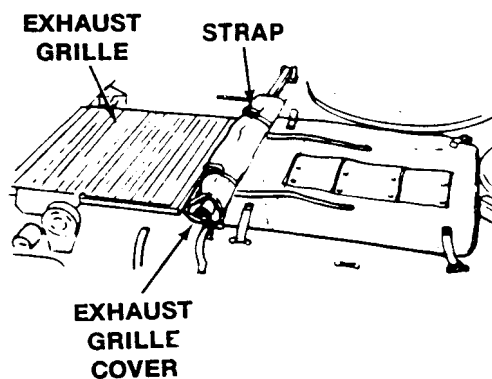

UNCOVER INTAKE GRILLE

1. Release two straps from footman loops on left side of intake grille.

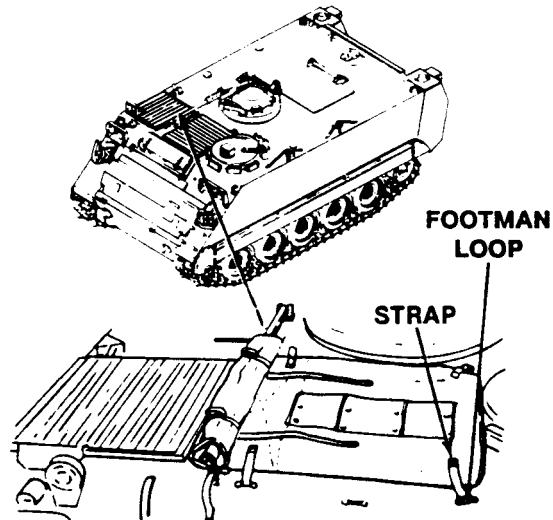

2. Roll intake grille cover toward area between intake and exhaust grilles and secure with two straps.

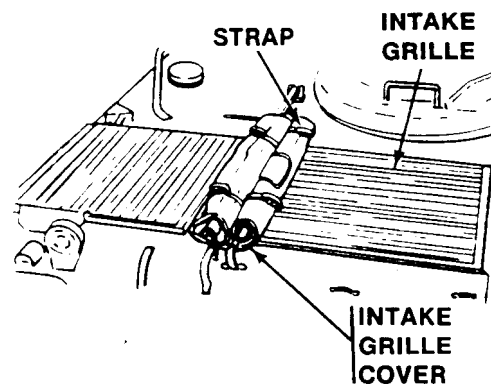

END OF TASK

OPERATE GLOW PLUG COLD START SYSTEM (MANUAL OVERRIDE)

0086 00

THIS WORK PACKAGE COVERS:

Operate (page 0086 00-1).

INITIAL SETUP:

Maintenance Level

Operator

Personnel Required

Driver

OPERATE

NOTE

If engine does not start during cold weather (engine temperature below 50°F), and glow plug WAIT indicator does not come on, this manual override procedure may be used.

1. Refer to Prepare To Start Engine (WP 0021 00), and Start Engine (-25° to +45°F) (WP 0021 00), and observe all pre-start steps and precautions.

CAUTION

Do not hold GLOW PLUG switch in ON position for more than two minutes.

2. Ensure that engine hand throttle is all the way in (idle position).

NOTE

Do not press accelerator pedal.

3. With power applied to carrier, push GLOW PLUG switch up (ON position) and hold for 35 seconds.

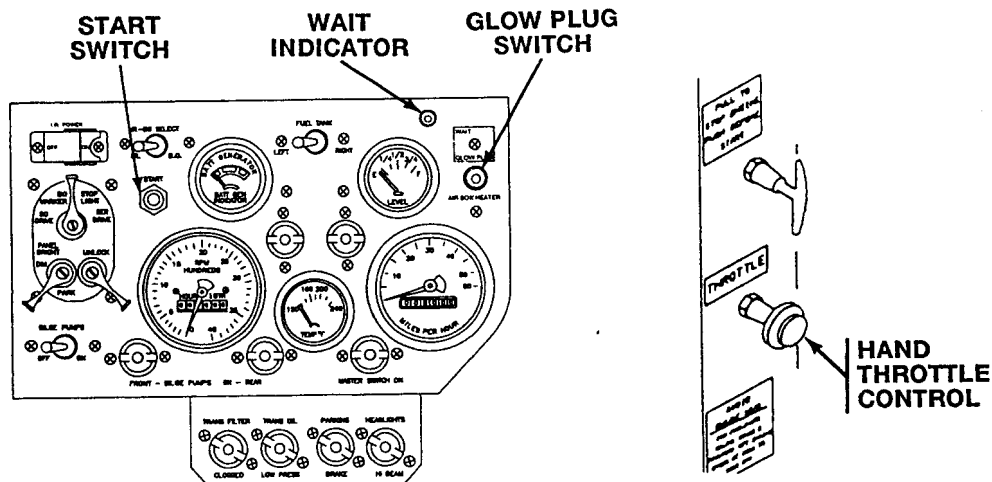

CAUTION

Do not engage START switch for more than five seconds (maximum) at a time.

4. Continue to hold GLOW PLUG switch while pushing START switch.

NOTE

If engine does not start, wait 10 seconds and repeat above procedure. If engine fails to start after four attempts, stop manual override procedure and notify unit maintenance.

5. After engine starts, release START switch. Continue to hold GLOW PLUG switch while slowly pressing throttle.
6. Release GLOW PLUG switch when engine is running. Raise engine speed until engine reaches 1200 RPM. Do not exceed 1800 RPM (maximum).

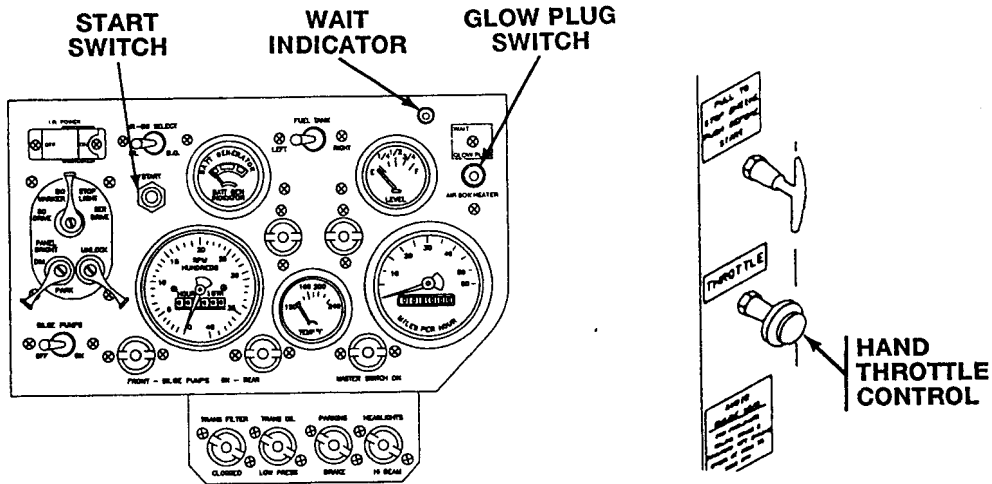

7. Reduce engine speed to 1000-1200 RPM. Hold until engine reaches normal operating temperature (190°-230°F).

END OF TASK

**ASSEMBLY AND PREPARATION FOR USE MORTAR FIRE
CONTROL SYSTEM (MFCS), M95 ONLY**

0086 01

THIS WORK PACKAGE COVERS:

- Installation of MFCS Equipment (page 0086 01-1).
 - Emplacing the Mortar on the M1064A3 Carrier (page 0086 01-6)
-

INITIAL SETUP:

Maintenance Level

Operator

References

TM 9-1015-250-10

TM 9-1220-248-10

Personnel Required

Gunner

Assistant Gunner

Ammunition Bearer

INSTALLATION OF MFCS EQUIPMENT

CAUTION

The Mortar Fire Control System (MFCS) is not intended for ground-mounted use. If mortar is to be employed in the ground-mounted mode, the pointing device (PD) and the PD mounting bracket **MUST** be removed.

To avoid equipment damage, always install dust cover/protective cap on cable and line replacement unit (LRU) connectors, as necessary.

CAUTION

Ensure power is turned off at power distribution assembly (PDA) before components are installed, to prevent damage to equipment.

CAUTION

To prevent equipment damage, do not handle computer by cable connecting keyboard to display area.

NOTE

Perform Steps 1 - 19 prior to mission if commander's interface (CI), gunner's display (GD), pointing device (PD), precision lightweight GPS receiver (PLGR) or defense advanced GPS receiver (DAGR), and driver's display (DD) are not in place in M1064A3 carrier.

**ASSEMBLY AND PREPARATION FOR USE MORTAR FIRE CONTROL
SYSTEM (MFCS), M95 ONLY — Continued**

0086 01

1. Obtain CI, GD, PD, PLGR/DAGR, and DD from secured place in accordance with unit standard operating procedure (SOP). If necessary, remove dust protective cap and connect keyboard cable (13) on computer (10).

NOTE
Steps 2 - 8 apply to installation of commander's interface (CI).

2. Ensure that computer mounting bracket (5) is secured to ram mount (2). Align two guide pins (11) of computer (10) with holes in two guide pin receptacles (12) of computer mounting bracket. Install computer on computer mounting bracket.
3. Align two retainer assemblies (4) with two locking fixtures (3) on computer (10). Tighten to secure computer.
4. Open spring snap on safety lanyard (1) and install in center hole of computer mounting bracket (5).
5. Align key on cable connector (15) with keyway in J1 connector (14). Install power/data cable connector to J1 connector on computer (10). Ensure that cable is in non-binding position.
6. Release rubber fastener (6) on each side of computer (10) and pull keyboard down and away from computer display area.
7. Place spring-loaded latch (8) on arm assembly (7) to secure keyboard at desired position.
8. If computer (10) is installed in the vehicle during travel, release spring-loaded latch (8) and fold keyboard against display area. Pull two rubber fasteners (6) into two U-shaped extensions (9) to secure keyboard. Position computer to avoid interference with commander's activities and to avoid contact with other interior items. Hand tighten ram mount (2).

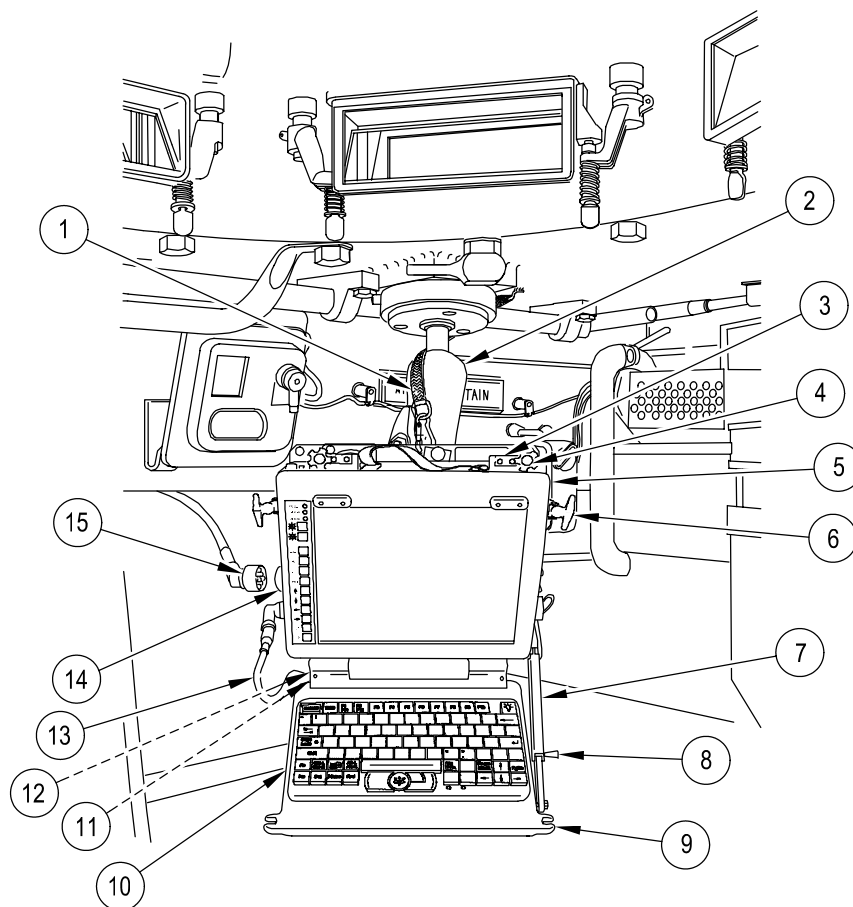

CAUTION

Ensure power is turned off at power distribution assembly before connection of PLGR/DAGR power cable, to prevent damage to equipment.

CAUTION

Ensure all connections are hand-tight to avoid damage to PLGR/DAGR.

To avoid damage to PLGR/DAGR, ensure that BA-5800 battery is removed from PLGR/DAGR before connection at external power source.

To avoid damage to MFCS system, ensure that on/off switch on PLGR/DAGR is turned off before installation of cables.

NOTE

Steps 9 - 10 apply to installation of PLGR/DAGR. Only PLGR is shown.

9. □ Connect MFCS cable to PLGR/DAGR (23). Reference TM 9-1220-248-10.

10. Position and secure PLGR/DAGR in its bracket (24).

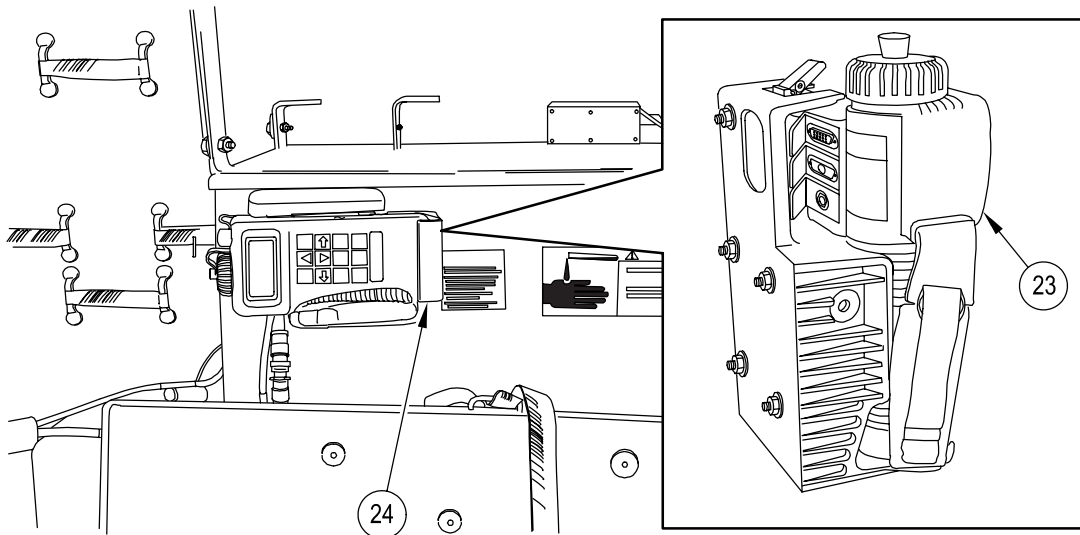

CAUTION

During movement of the M1064A3 carrier, the cannon must be locked in travel position to prevent damage to equipment and false readings in the software.

NOTE

Steps 11 - 15 apply to installation of cannon with pointing device (PD) attached.

11. The gunner, assistant gunner, and ammunition bearer carry cannon (25) with attached mounting assembly (26) and PD (31) into the M1064A3 carrier.

CAUTION

To prevent damage to PD, do not allow cannon (with PD attached) to be placed at rest using mounting assembly as supporting component during installation of cannon.

12. The gunner and assistant gunner position cannon (25) in breech cap socket (29) with white line facing up.
13. The ammunition bearer lifts the bipod assembly (33) into position and the assistant gunner locks the clamp handle assembly (34), securing the buffer housing assembly (35).

CAUTION

To avoid damage to equipment, do not connect any cable to J3 connector on PD.

14. Connect data cable (27) to J2 connector (30) on PD (31).
15. Connect power supply cable (28) to J1 connector (32) on PD (31).

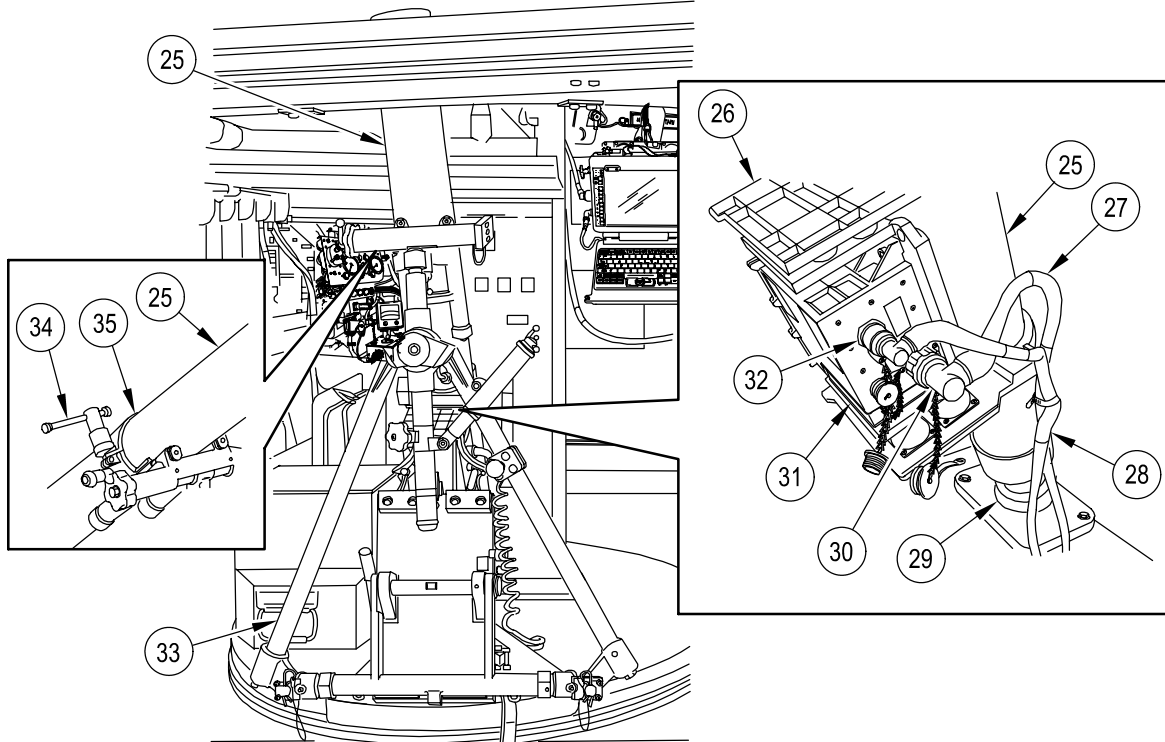

NOTE

Step 16 applies to installation of gunner's display (GD) on bipod.

NOTE

Do not press TEST button on gunner's display during firing operations. Complete system re-initialization will be required.

NOTE

If GD is mounted on back wall, see GD alternate location insert.

16. Connect power/data cable 3W5 (38) to J1 connector (37) on GD (36).

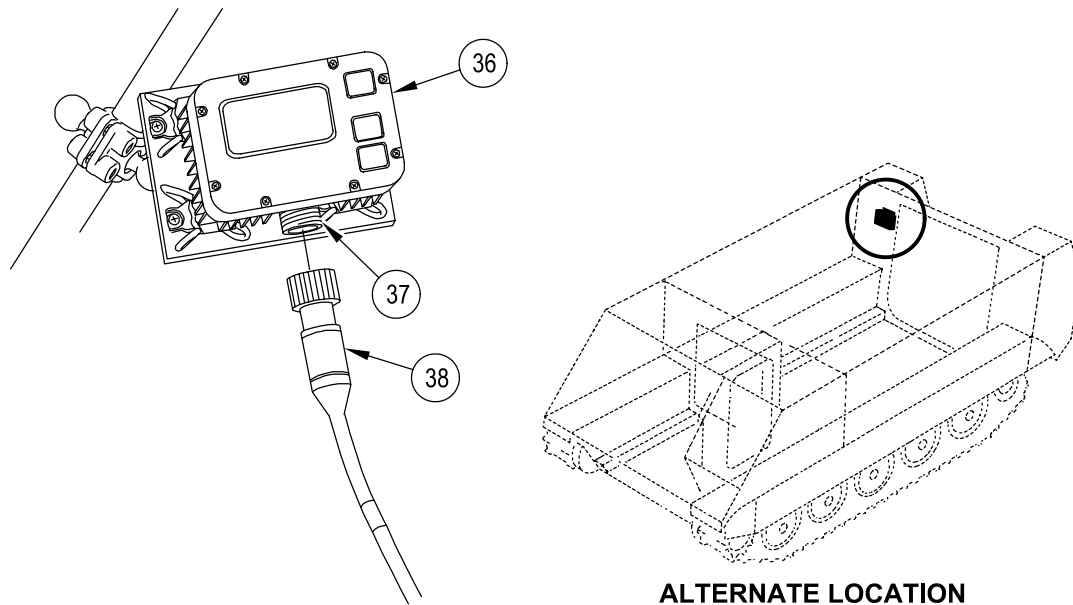

NOTE

Steps 17 - 19 apply to installation of driver's display (DD).

DD may be positioned either on the interior mount in the driver's compartment or on the exterior mounting ball. Follow these instructions to install DD to desired position.

17. Loosen T-handle (45) on locking clamp (44) to allow installation of DD (48) on ball on interior mount (43) or exterior mounting ball (49).
18. Place locking clamp (44) around mounting ball in desired location. Tighten T-handle (45) to secure DD (48).
19. Connect power/data cable (47) to J1 connector (46) on DD (48).

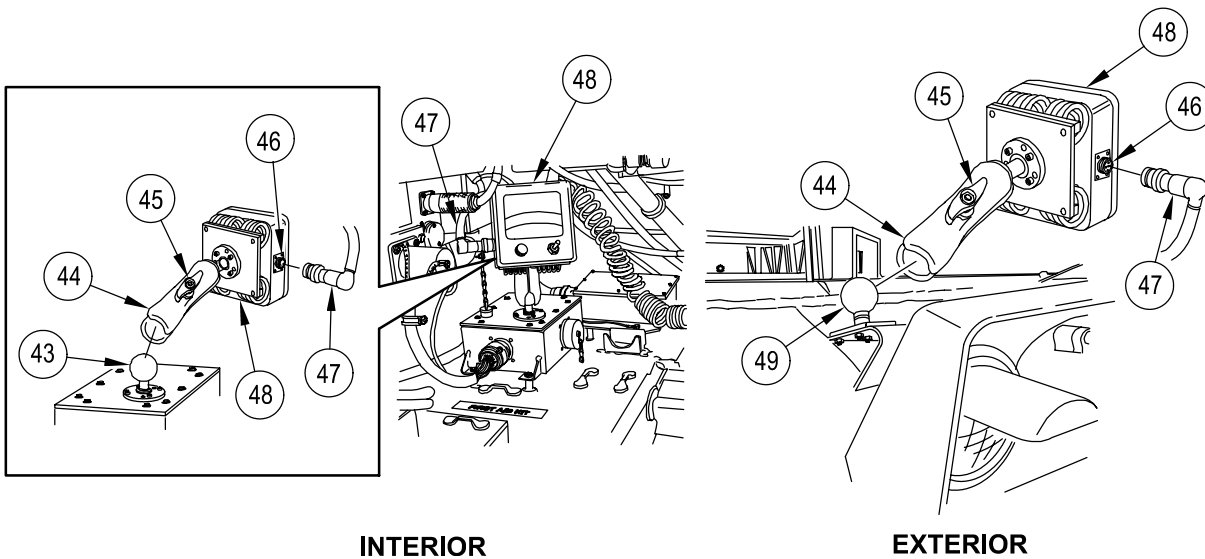

EMPLACING THE MORTAR ON THE M1064A3 CARRIER

1. Refer to TM 9-1015-250-10.

END OF TASK

CHAPTER 3

OPERATOR TROUBLESHOOTING PROCEDURES

WORK PACKAGE INDEX

<u>Title</u>	<u>Sequence No.</u>
INTRODUCTION TO TROUBLESHOOTING.....	0087 00
TROUBLESHOOTING SYMPTOM INDEX.....	0088 00
TROUBLESHOOTING TABLES.....	0089 00

INTRODUCTION TO TROUBLESHOOTING

0087 00**TROUBLESHOOTING SYMPTOM INDEX**

The Troubleshooting Symptom Index (WP 0088 00) lists common malfunctions that may occur during operation or crew servicing of the carrier and its components.

The Troubleshooting Symptom Index is divided into sections. Each section covers malfunctions common to the different systems of the carrier (e.g., engine, transmission, suspension, etc.).

Identify the malfunction that best describes your problem and turn to the appropriate Troubleshooting Table in WP 0089 00.

TROUBLESHOOTING TABLES

The Troubleshooting Tables work package (WP 0089 00) contains tables listing the malfunctions, tests or inspections, and corrective actions required to return the systems to normal operation. Perform the steps in the order they appear in the tables.

Each table is headed by an initial setup. This setup outlines what is needed as well as certain conditions which must be met before starting the task.

The Troubleshooting Tables have three columns — MALFUNCTION, TEST OR INSPECTION, and CORRECTIVE ACTION.

The MALFUNCTIONs (symptoms) are numbered in sequence through the Troubleshooting Table.

The TEST OR INSPECTION is a step you take to isolate the fault that causes the MALFUNCTION. Each TEST OR INSPECTION has a CORRECTIVE ACTION.

The CORRECTIVE ACTIONs are the statements which tell you what to do to correct the fault.

This manual cannot list all possible malfunctions, nor all the tests or inspections and corrective actions. It is essential that you record all faults on DA Form 2404 and report it to unit maintenance. If a malfunction is not listed, or is not corrected by the listed corrective action, notify unit maintenance.

TROUBLESHOOTING SYMPTOM INDEX

0088 00

NOTE

- For Smoke Obscurant System troubleshooting of M58, see TM 3-1040-285-10.
- For SCIPS troubleshooting of M1068A3, see TM 11-7010-256-12&P.
- For MCPS troubleshooting of M1068A3, see TM 10-8340-243-13&P.
- For Smoke Generator troubleshooting of M1059A3, see TM 3-1040-279-12&P.
- For AN/VVS-5 Driver's Vision Enhancer (DVE) troubleshooting (M58 only), see TM 11-5855-311-12&P.
- For 5.0 kw APU troubleshooting of (M1068A3/M577A3, see TM 9-6115-664-13&P

BILGE PUMPS

Bilge pumps does not work with BILGE PUMPS switch ON.....0089 00-15

ELECTRICAL SYSTEM

Batteries discharged.....0089 00-11
 No battery current.....0089 00-11
 Fuel level gage fails to register.....0089 00-11
 With MASTER SWITCH ON, MASTER SWITCH ON indicator light does
 not come on.....0089 00-11
 No image through driver's night viewer (carrier power used).....0089 00-11
 No image through driver's night viewer (2.7 volt battery used).....0089 00-11
 Image too bright through driver's night viewer.....0089 00-11
 Image dim (carrier power used).....0089 00-11
 Image dim (2.7 volt battery used).....0089 00-11
 Poor image quality through driver's night viewer.....0089 00-11

ENGINE

Engine does not crank when you press START switch.....0089 00-1
 Engine cranks but does not start.....0089 00-1
 Engine cranks but does not start when temperature is below +40° F (+4° C)
 and air box heater is used.....0089 00-1
 Engine cranks too slow to start.....0089 00-1
 Engine labors, runs rough, stalls, or does not put out full power.....0089 00-1
 Engine overheats.....0089 00-1
 ENGINE OIL LOW PRESS warning light comes on.....0089 00-1
 ENGINE COOLANT LEVEL LOW warning light comes on.....0089 00-1

ENGINE COOLANT HEATER

Heater does not start with RUN-OFF-START SWITCH held in START
 position. Heater motor runs.....0089 00-19
 Heater does not start with RUN-OFF-START SWITCH held in START
 position. Heater motor does not run.....0089 00-19
 Coolant heater overheats.....0089 00-19
 Coolant heater output is too low.....0089 00-19
 Batteries overheat.....0089 00-19

FINAL DRIVE

Final drive runs hot.....0089 00-7

NBC KIT

Insufficient air flow at all stations.....0089 00-21
 Air flow too high at all stations.....0089 00-21

TROUBLESHOOTING SYMPTOM INDEX — Continued

0088 00

Gas particulate filter will not operate when switch is in ON position.....0089 00-21

PERSONNEL HEATER

Heater does not start with RUN-OFF-START SWITCH held in START position. Heater motor runs.....0089 00-17
 Heater does not start with RUN-OFF-START SWITCH held in START position. Heater motor does not run.....0089 00-17
 Heater overheats and stops.....0089 00-17
 Heater overheats and does not stop.....0089 00-17
 Heater does not put enough heat.....0089 00-17

TRACKS AND SUSPENSION

Carrier pulls to one side.....0089 00-9
 Carrier throws track.....0089 00-9
 Too much noise in track or suspension.....0089 00-9
 Carrier rides too hard.....0089 00-9

TRANSMISSION

Transmission does not drive in any range.....0089 00-5
 TRANS OIL LOW PRESS warning light comes on.....0089 00-5
 TRANS OIL HI TEMP warning light comes on.....0089 00-5
 TRANS FILTER CLOGGED warning light comes on.....0089 00-5

TROUBLESHOOTING TABLE

0089 00

INITIAL SETUP:

Maintenance Level

Operator

ENGINE

MALFUNCTION	TEST OR INSPECTION	CORRECTIVE ACTION
1. ENGINE DOES NOT CRANK WHEN YOU PRESS START SWITCH.	1. Check to see if MASTER SWITCH is OFF.	Turn MASTER SWITCH to ON.
	2. Check to see if transmission controller is in SL position.	Place transmission controller in SL position (WP 0004 00).
	3. Check to see if batteries are in good condition.	Troubleshoot electrical system (0089 00-11).
2. ENGINE CRANKS BUT DOES NOT START.	1. Check to see if fuel cutoff control is pulled out.	Push fuel cutoff control in (WP 0021 00).
	2. Check to see if there is enough fuel in fuel tanks.	Refuel carrier; all except M577A3 and M1068A3 (WP 0025 00); M577A3 and M1068A3 (WP 0026 00).
	3. Check to see if fuel tank manual shutoff valves are closed.	Open fuel tank manual shutoff valves (WP 0004 00).
	4. If air temperature is colder than +40° F (+4° C), check to see if AIR BOX HEATER switch is ON, or GLOW PLUG switch is operated.	Use air box heater, or glow plug (WP 0021 00).
	5. Check to see if there is water in the fuel.	Drain primary and secondary fuel filters (WP 0090 00).
	6. Check to see if engine is getting enough air.	Clear intake grille of any debris.
	7. Check air cleaner restriction indicator (WP 0098 00).	If indicator shows only red in the window, notify unit maintenance. If engine still does not start, notify unit maintenance.
3. ENGINE CRANKS BUT DOES NOT START WHEN THE TEMPERATURE IS BELOW +40° F (+4° C) AND THE AIR BOX HEATER IS USED.	1. Check to see if there are any loose connections.	Tighten any loose connections. Notify unit mechanic.
4. ENGINE CRANKS TOO SLOW TO START.	1. Check to see if battery cable connections are clean and tight, and battery water is up to correct level (WP 0095 00).	Use outside power source (WP 0022 00) or tow start (WP 0078 00) the carrier. If the cause of slow cranking is not obvious, have unit maintenance troubleshoot the electrical system.

MALFUNCTION	TEST OR INSPECTION	CORRECTIVE ACTION
<p>5. ENGINE LABORS, RUNS ROUGH, STALLS, OR DOES NOT PUT OUT FULL POWER.</p>	<ol style="list-style-type: none"> 1. Check to see if engine is getting enough air. Check engine air cleaner restriction indicator (WP 0098 00). 2. Check to see if there is water in the fuel. 3. Check elevation. 	<p>If indicator shows only red in the window, notify unit maintenance.</p> <p>Drain primary and secondary fuel filters (WP 0090 00).</p> <p>The carrier will normally lose power at high elevations (mountain passes or high plateaus). If carrier runs rough or power loss is bad, notify unit maintenance.</p>
<p>6. ENGINE OVERHEATS.</p>	<p style="text-align: center;">CAUTION</p> <p>Driving carrier with an overheated engine can damage engine. When ENGINE COOLANT TEMPERATURE GAUGE indicates above 230° F (110° C), stop carrier and run engine at 1000-1200 RPM until coolant temperature drops below 230° F (110° C).</p> <ol style="list-style-type: none"> 1. Check to see if all power plant access panels are in place and mounting clamps are tight. 2. If hard running in hot weather, follow the precautions for driving in extreme heat (WP 0074 00) 	<p>Install power plant access panels (WP 0040 00).</p> <p>When engine overheats, stop carrier and run engine at 1000-1200 RPM until coolant temperature drops below 230° F (110° C).</p>

MALFUNCTION	TEST OR INSPECTION	CORRECTIVE ACTION
	<p style="text-align: center;">WARNING</p> <div style="text-align: center;">  </div> <p>Hot radiator coolant can burn you. Use hand to remove cap only if cool to touch. Turn cap slowly to release pressure. Replace cap by pressing down and turning cap until tight.</p> <ol style="list-style-type: none"> 3. Check to see if coolant level is low. (ENGINE COOLANT LOW LEVEL WARNING LIGHT should indicate low coolant level. If coolant level is low and warning light did not come on, notify unit maintenance.) 4. Check to see if radiator cap is sealed right. 5. Check to see if there is enough air moving through intake grille and radiator. 6. Check to see if coolant fan is working right. 7. Check to see if engine oil level is low. 	<p>Add coolant as needed (WP 0097 00). Check for coolant leaks. If you find any, notify unit maintenance.</p> <p>Make sure cap is on straight and tight (WP 0097 00). If cap is damaged or seal is broken, notify unit maintenance.</p> <p>Remove any debris from intake grille, exhaust grille, and radiator fins.</p> <p>Look for any loose or broken fan belts (WP 0090 00). If any belt is broken, worn, or loose, notify unit maintenance.</p> <p>Add oil as needed (WP 0090 00).</p>

MALFUNCTION	TEST OR INSPECTION	CORRECTIVE ACTION
<p>7. ENGINE OIL LOW PRESS WARNING LIGHT COMES ON.</p>	<p>8. Check coolant fan drive system:</p> <ol style="list-style-type: none"> a. Stop engine (WP 0024 00). b. Remove top rear power plant access panel (WP 0040 00). c. Pull on coolant fan drive belt to see if coolant fan will turn (WP 0090 00). <p style="text-align: center;">CAUTION</p> <p>Operating carrier with an ENGINE OIL LOW PRESS warning light on can damage engine. If ENGINE OIL LOW PRESS warning light does not go off within 10 seconds after engine starts, stop engine.</p> <ol style="list-style-type: none"> 1. Check to see if engine oil level is low. 2. Check to see if engine is overheating. 	<p>If coolant fan does not turn, coolant fan drive system is broken. Do not operate carrier. Notify unit maintenance.</p> <p>If coolant fan turns, push in and turn thermostatic fan speed switch bypass button to the left (old configuration) or move toggle switch to the UP position for manual fan speed OVERRIDE (new configuration). Install top rear power plant access panel (WP 0040 00). Start engine (WP 0021 00). Drive carrier under similar conditions of reported overheat. Notify unit maintenance that thermostatic fan speed switch bypass button (old configuration) or manual fan speed override switch (new configuration) has been activated. If engine overheats, stop engine immediately (WP 0024 00). Notify unit maintenance.</p>
<p>8. ENGINE COOLANT LOW LEVEL WARNING LIGHT COMES ON.</p>	<ol style="list-style-type: none"> 1. Check to see if coolant level is low. 	<p>Add oil as needed (WP 0090 00).</p> <p>See ENGINE OVERHEATS (0089 00-1).</p> <p>Add coolant as needed (WP 0097 00). Check for coolant leaks. If you find any leaks, notify unit maintenance.</p>

TROUBLESHOOTING TABLE — Continued

0089 00

INITIAL SETUP:

Maintenance Level

Operator

TRANSMISSION

MALFUNCTION	TEST OR INSPECTION	CORRECTIVE ACTION
<p>1. TRANSMISSION DOES NOT DRIVE IN ANY RANGE.</p> <p>2. TRANS OIL LOW PRESS WARNING LIGHT COMES ON.</p>	<p>1. Check transmission to final drive shafts to see if they have been disconnected.</p> <p>2. Check for low transmission oil level.</p> <p>3. Check for broken track.</p> <p>4. Check transmission controller.</p> <p style="text-align: center;">CAUTION</p> <p>Operating carrier with TRANS OIL LOW PRESS warning light on can damage transmission and may result in unpredictable carrier operation. DO NOT OPERATE carrier with TRANS OIL LOW PRESS warning light on.</p> <p>1. Reduce throttle to idle and stop vehicle on level ground. With transmission oil at operating temperature (engine coolant temp gauge at 200° F), set shift control to SL and release brakes.</p> <p>2. Check TRANS FILTER CLOGGED warning light.</p>	<p>If disconnected, notify unit maintenance.</p> <p>Add oil as needed (WP 0090 00).</p> <p>Repair track ((T130)((WP009300) or ((T150)((WP009301).</p> <p>If defective, notify unit maintenance.</p> <p>If TRANS FILTER CLOGGED warning light is lit, shut down engine and notify unit maintenance.</p> <p>If TRANS FILTER CLOGGED warning light is not lit, go to Step</p>

MALFUNCTION	TEST OR INSPECTION	CORRECTIVE ACTION
<p>3. TRANS OIL HI TEMP WARNING LIGHT COMES ON.</p> <p>4. TRANS FILTER CLOGGED WARNING LIGHT COMES ON.</p>	<p>3. Check transmission oil level.</p> <p>4. Increase engine speed to 1200-1300 RPM.</p> <p>5. Check warning light.</p> <p style="text-align: center;">CAUTION</p> <p>Operating carrier with TRANS OIL HI TEMP warning light on can damage transmission. DO NOT OPERATE carrier with TRANS OIL HI TEMP warning light on.</p> <p>1. Bad driving habits.</p> <p>2. Check to see if transmission oil level is low.</p> <p>3. Check to see if coolant level is low.</p>	<p>If transmission oil level is low, add oil as needed (WP 0090 00). Then go to Step 5.</p> <p>If transmission oil level is OK, go to Step 4.</p> <p>If TRANS OIL LOW PRESS warning light goes off, continue normal operation.</p> <p>If TRANS OIL LOW PRESS warning light stays lit or lights again, shut down engine and notify unit maintenance.</p> <p>Do not drive with transmission controller in range 1 any longer than you have to.</p> <p>Add oil as needed (WP 0090 00).</p> <p>Add coolant as needed (WP 0097 00). Check for coolant leaks. If leaks are found, notify unit maintenance.</p> <p>Notify unit maintenance.</p>

TROUBLESHOOTING TABLE — Continued

0089 00

INITIAL SETUP:

Maintenance Level

Operator

FINAL DRIVE

MALFUNCTION	TEST OR INSPECTION	CORRECTIVE ACTION
1. FINAL DRIVE RUNS HOT.	1. Check to see if final drive oil level is low.	Add oil as needed (WP 0090 00).

INITIAL SETUP:

Maintenance Level

Operator

TRACKS AND SUSPENSION

MALFUNCTION	TEST OR INSPECTION	CORRECTIVE ACTION
1. CARRIER PULLS TO ONE SIDE.	1. Check for crowned road or sloping ground. 2. Check to see if track tension is equal on both sides. 3. Check to see if mud, dirt, debris, or snow has built up on one track.	The carrier will normally pull to one side of any slope. Adjust track tension (T130) (WP 0091 00) or (T150) (WP 0091 01). Clear track of debris.
2. CARRIER THROWS TRACK.	1. Check to see if track is loose or worn. 2. Check for bad driving habits.	Adjust track tension (T130) (WP 0091 00) or (T150) (WP 0091 01). Do not use pivot steer when carrier is moving. Avoid sharp turns at high speed or in soft ground.
NOTE		
Keep track clear. On soft ground or in heavy brush, turn in a series of short turns so track can clear itself.		
3. TOO MUCH NOISE IN THE TRACK OR SUSPENSION.	3. Check to see if dirt, mud, or other material has built up in the track.	Clear track of debris.
3. TOO MUCH NOISE IN THE TRACK OR SUSPENSION.	1. Check to see if wrong tension is on track. 2. Check to see if track shoes are badly worn. 3. Check to see if track pads are loose, worn, or missing. 4. Check to see if sprockets or cushions are worn (WP 0090 00).	Adjust track tension (T130) (WP 0091 00) or (T150) (WP 0091 01). If shoes are worn, notify unit maintenance. Tighten loose pads. If any pads are worn or missing, notify unit maintenance. If sprockets or cushions are worn, notify unit maintenance.
4. CARRIER RIDES TOO HARD.	1. Check shock absorbers for leaks. 2. Feel shock absorbers after running. 3. Check to see if carrier has any broken torsion bars (WP 0090 00).	If shock absorbers leak, notify unit maintenance. Good shocks will be noticeably warmer than the hull. A cool shock is a faulty one. Notify unit maintenance If carrier has broken torsion bars, notify unit maintenance.

INITIAL SETUP:

Maintenance Level

Operator

ELECTRICAL SYSTEM

MALFUNCTION	TEST OR INSPECTION	CORRECTIVE ACTION
1. BATTERIES DISCHARGED.	<ol style="list-style-type: none"> 1. Check to see if battery water level is low (WP 0095 00). 2. Too much use of electrical equipment when the engine is not running. 3. Check to see if battery cables are loose, disconnected, or corroded. 4. Check engine generator drive belt. 	<p>Add distilled water.</p> <p>Run the engine periodically to recharge the batteries.</p> <p>Notify unit maintenance.</p> <p>If belt is loose, broken, or missing, notify unit maintenance.</p>
2. NO BATTERY CURRENT.	<ol style="list-style-type: none"> 1. Check to see if battery cables are loose, disconnected, or corroded. 	<p>Notify unit maintenance.</p>
3. FUEL LEVEL GAUGE FAILS TO REGISTER.	<ol style="list-style-type: none"> 1. Check to see if there is fuel in the fuel tanks. 2. Check to see if MASTER SWITCH is in OFF position. 3. Check for disconnected or faulty fuel level gauge lead. 	<p>Refuel carrier (for all except M577A3 and M1068A3, see WP 0025 00; for M577A3 and M1068A3, see WP 0026 00).</p> <p>Turn MASTER SWITCH to ON.</p> <p>Connect disconnected lead. If lead is faulty, notify unit maintenance.</p>
4. WITH MASTER SWITCH ON, MASTER SWITCH ON INDICATOR LIGHT DOES NOT COME ON.	<ol style="list-style-type: none"> 1. Check to see if lamp is burned out or there are loose connections in the lamp leads. 2. Check battery indicator gauge to see if batteries are dead. Check for faulty or loose battery connectors. 	<p>If battery gauge shows normal reading (WP 0090 00) and other electrical equipment and lights are working, lamp is faulty. You can drive carrier, but be sure to turn MASTER SWITCH to OFF when you shut down carrier. Notify unit maintenance.</p> <p>Notify unit maintenance to tighten loose battery cable connectors. If you have to operate carrier with dead batteries, tow start (WP 0078 00) or use outside power source (WP 0022 00) to start the engine.</p>
5. NO IMAGE THROUGH DRIVER'S NIGHT VIEWER (CARRIER POWER USED) (AN/VVS-2(V)1A).	<ol style="list-style-type: none"> 1. Check to see if OFF/BRIGHT rotary switch is set on OFF. 	<p>Rotate OFF/BRIGHT rotary switch to maximum BRIGHT position.</p>

MALFUNCTION	TEST OR INSPECTION	CORRECTIVE ACTION
<p>6. NO IMAGE THROUGH DRIVER'S NIGHT VIEWER (2.7 VOLT BATTERY USED) (AN/VVS-2(V)1A).</p>	<p>2. Check to see if MASTER SWITCH and DNV switch are ON.</p> <p>3. Check to see if entrance window cover is installed.</p> <p style="text-align: center;">NOTE</p> <p>If outside light is too bright, driver's night viewer will not operate and entrance window cover should be installed.</p> <p>4. Check light conditions outside. If too bright, driver's night viewer will not operate.</p> <p>1. Check to see if OFF/BRIGHT rotary switch is set to OFF.</p> <p>2. Check to see if battery compartment cap is loose.</p> <p>3. Check to see if 2.7 volt battery is dead.</p> <p style="text-align: center;">NOTE</p> <p>If outside light is too bright, driver's night viewer will not operate and entrance window cover should be installed.</p> <p>4. Check light conditions outside. If too bright, driver's night viewer will not operate.</p> <p>5. Check 2.7 volt battery for proper installation.</p> <p>6. Check to see if entrance window protective cover is installed.</p>	<p>Turn MASTER SWITCH and DNV switch to ON.</p> <p>Turn MASTER SWITCH and DNV switch to OFF.</p> <p>Disconnect driver's night viewer power cable and operate driver's night viewer using 2.7 volt battery.</p> <p>Remove entrance window protective cover.</p> <p>Point driver's night viewer at darker scene.</p> <p>Rotate OFF/BRIGHT rotary switch to maximum BRIGHT position.</p> <p>Secure battery compartment cap.</p> <p>Replace 2.7 volt battery.</p> <p>Point driver's night viewer at darker scene.</p> <p>Install 2.7 volt battery with recessed end (+) first into battery compartment.</p> <p>Remove entrance window protective cover.</p>
<p>7. IMAGE TOO BRIGHT THROUGH DRIVER'S NIGHT VIEWER (AN/VVS-2(V)1A).</p>	<p>1. Check to see if OFF/BRIGHT rotary switch is correctly adjusted.</p>	<p>Adjust OFF/BRIGHT switch.</p>

TROUBLESHOOTING TABLE — Continued

0089 00

MALFUNCTION	TEST OR INSPECTION	CORRECTIVE ACTION
8. IMAGE DIM (CARRIER POWER USED) (AN/VVS-2(V)1A).	1. Check OFF/BRIGHT rotary switch position. 2. Check if carrier battery has a charge.	Adjust OFF/BRIGHT rotary switch for best image. Start engine (WP 0021 00) to charge carrier batteries.
9. IMAGE DIM (2.7 VOLT BATTERY USED) (AN/VVS-2(V)1A).	1. Check OFF/BRIGHT rotary switch position. 2. Check if 2.7 volt battery has a charge.	Adjust OFF/BRIGHT rotary switch for best image. Replace 2.7 volt battery.
10. POOR IMAGE QUALITY THROUGH DRIVER'S NIGHT VIEWER (AN/VVS-2(V)1A).	1. Check to see if entrance window or eyepiece lens is dirty or foggy. 2. Check to see if carrier batteries are charged. 3. Check to see if 2.7 volt battery is damaged.	Clean entrance window and eyepiece lens. Start engine (WP 0021 00) to charge batteries or disconnect driver's night viewer power plug and install 2.7 volt battery. Replace 2.7 volt battery.
11. FOR DRIVER'S NIGHT VISION ENHANCER (DVE) AN/VVS-5(V)1, SEE TM 11-5855-311-12&P-1 FOR TROUBLESHOOTING THE DISPLAY & SENSOR ONLY.		
12. NO IMAGE THROUGH DVE DISPLAY.	1. Check to see if sensor window cover is installed. 2. Check for faulty or loose cables.	Remove sensor window cover. Tighten power cable connector on driver's hatch. If broken connectors or cut wires, notify unit maintenance.

INITIAL SETUP:

Maintenance Level

Operator

BILGE PUMPS

MALFUNCTION	TEST OR INSPECTION	CORRECTIVE ACTION
<p>1. BILGE PUMP DOES NOT WORK WITH THE BILGE PUMPS SWITCH ON.</p>	<p>1. Check to see if MASTER SWITCH is OFF.</p> <p>2. Check to see if bilge pump strainers or outlets are clogged.</p> <p>3. Check to see if bilge pump vents are blocked.</p>	<p>Turn MASTER SWITCH to ON.</p> <p>Clean bilge pump strainers or outlets (WP 0096 00).</p> <p>Clean bilge pump vents (WP 0096 00). If you cannot get to the bilge pump to clean it because of a load in the personnel compartment, cycle the BILGE PUMP switch ON and OFF (WP 0004 00) a few times. That will usually start the pump.</p>

INITIAL SETUP:

Maintenance Level

Operator

PERSONNEL HEATER

NOTE

For troubleshooting Model A20 personnel heater with P/N 5000-30178 see TM 9-2540-207-14&P. For troubleshooting personnel heaters with P/N D55350-G1 and 10560M24B1 use table below.

MALFUNCTION	TEST OR INSPECTION	CORRECTIVE ACTION
1. HEATER DOES NOT START WITH THE RUN-OFF-START SWITCH HELD IN START POSITION. HEATER MOTOR RUNS.	1. Check to see if fuel tanks manual shutoff valves are closed.	Open fuel tanks manual shutoff valves (WP 0004 00).
	2. Check diagnostic display on heater for diagnostic fault code (Model A20 only).	Notify unit maintenance.
2. HEATER DOES NOT START WITH THE RUN-OFF-START SWITCH HELD IN START POSITION. HEATER MOTOR DOES NOT RUN.	1. Push PRESS-TO-TEST switch on personnel heater control box to test for electrical power. If light does not work, check for loose electrical connections at control box and heater.	Tighten loose connections.
	2. Check to see if battery connections are tight.	Notify unit maintenance.
	3. Check diagnostic display on heater for diagnostic fault code (Model A20 only).	Notify unit maintenance.
3. HEATER OVERHEATS AND STOPS.	1. Check to see if heater intake elbow, exhaust elbow, or warm air outlet is blocked.	Remove whatever is blocking the heater system (WP 0028 00).
	2. Check diagnostic display on heater for diagnostic fault code (Model A20 only).	Notify unit maintenance.
4. HEATER OVERHEATS AND DOES NOT STOP.	1. Check to see if personnel heater fuel supply valve is OFF.	Turn personnel heater fuel supply valve OFF (WP 0028 00).
	2. Allow heater to run for 2-3 minutes to burn off fuel in heater.	Disconnect electrical connector from heater.
	3. Check diagnostic display on heater for diagnostic fault code (Model A20 only).	Notify unit maintenance.
5. HEATER DOES NOT PUT OUT ENOUGH HEAT.	1. Check to see if HI-LO switch is in LO position.	Move HI-LO switch to HI position (WP 0028 00).
	2. Check diagnostic display on heater for diagnostic fault code (Model A20 only).	Notify unit maintenance.

INITIAL SETUP:

Maintenance Level

Operator

ENGINE COOLANT HEATER

MALFUNCTION	TEST OR INSPECTION	CORRECTIVE ACTION
1. HEATER DOES NOT START WITH RUN-OFF-START SWITCH HELD IN START POSITION. HEATER MOTOR RUNS.	1. Check to see if fuel tanks manual shutoff valves are closed.	Open fuel tanks manual shutoff valves (WP 0004 00).
2. HEATER DOES NOT START WITH RUN-OFF-START SWITCH HELD IN START POSITION. HEATER MOTOR DOES NOT RUN.	1. Push PRESS-TO-TEST switch on engine coolant heater control box to test for electrical power. If light does not work, check for loose electrical connections at control box and heater. 2. Check to see if battery connections are tight.	Tighten loose connections. Notify unit maintenance to tighten loose battery connections.
3. COOLANT HEATER OVERHEATS.	1. Check to see if one or both coolant shutoff valves are closed.	Open coolant shutoff valves (WP 0062 00).
4. COOLANT HEATER OUTPUT IS TOO LOW.	1. Check to see if the HI-LO switch is in LO position.	Move HI-LO switch to HI position (WP 0062 00).
5. BATTERIES OVERHEAT.	1. The air temperature is too warm to need the engine coolant heater 2. The engine is running at the same time as the engine coolant heater.	Turn off engine coolant heater (WP 0062 00). You do not need to use engine coolant heater if temperature is above -25 ^o F (-32 ^o C). Turn off engine coolant heater (WP 0062 00) as soon as the engine starts.

TROUBLESHOOTING TABLE — Continued

0089 00

INITIAL SETUP:

Maintenance Level

Operator

NBC KIT

MALFUNCTION	TEST OR INSPECTION	CORRECTIVE ACTION
1. INSUFFICIENT AIR FLOW AT ALL STATIONS.	1. Check to see if spring clip is down over air intake openings on air purifier. 2. Check to see if air hoses are kinked or pinched. 3. Check to see if there are any loose hose connections.	Raise spring clip from air intake openings on air purifier (WP 0081 00). Straighten or replace air hoses (WP 0081 00). Tighten loose hose connections (WP 0081 00).
2. AIR FLOW TOO HIGH AT ALL STATIONS.	1. Check to see if air purifier is out of adjustment.	If air purifier is out of adjustment, notify unit maintenance.
3. GAS PARTICULATE FILTER WILL NOT OPERATE WHEN SWITCH IS IN ON POSITION.	1. Check to see if AIR PURIFIER SWITCH is in OFF position. 2. Check to see if ground wire is loose or missing. 3. Check to see if electrical cable assemblies are loose or missing.	Turn AIR PURIFIER SWITCH to ON. Notify unit maintenance of loose or missing ground wire. Notify unit maintenance.

CHAPTER 4

MAINTENANCE INSTRUCTIONS
FOR MAINTENANCE OF CARRIER

WORK PACKAGE INDEX

<u>Title</u>	<u>Sequence No.</u>
PREVENTIVE MAINTENANCE CHECKS AND SERVICES.....	.0090 00
ADJUST T130 TRACK TENSION.....	.0091 00
ADJUST T150 TRACK TENSION.....	.0091 01
BREAK/JOIN T130 TRACK.....	.0092 00
BREAK/JOIN T150 TRACK.....	.0092 01
REMOVE/INSTALL T130 TRACK SHOE.....	.0093 00
REMOVE/INSTALL T150 TRACK SHOE.....	.0093 01
TRACK SHOE WEAR LIMITS.....	.0094 00
ASSEMBLE T130 TRACK SHOE SECTIONS OFF VEHICLE.....	.0094 01
CHECK CARRIER BATTERIES.....	.0095 00
SERVICE BILGE PUMPS.....	.0096 00
CHECK/FILL COOLING SYSTEM.....	.0097 00
MAINTENANCE OF AIR CLEANER.....	.0098 00
CHECK/REPLACE MISSING PLUG (M113A3 ONLY).....	.0099 00
SERVICE SMOKE GENERATOR FUEL CAN/FOG OIL TANK (M1059A3).....	.0100 00

PREVENTIVE MAINTENANCE CHECKS AND SERVICES

0090 00

THIS WORK PACKAGE COVERS:

- Before (Table 3, page 0090 00-9).
- During (Table 4, page 0090 00-48).
- After (Table 5, page 0090 00-62).
- Weekly (Table 6, page 0090 00-100).
- Monthly (Table 7, page 0090 00-127).
- Semi-annually (Table 8, page 0090 00-128).

INITIAL SETUP:

<u>Maintenance Level</u>	<u>References</u>
Operator	DA PAM 750-8
	FM 9-207
<u>Tools and Special Tools</u>	TB 43-0211
Grease gun adapter (WP 0102 00, Item 18)	TM 3-1040-283-10
Industrial goggles (WP 0103 00)	TM 3-1040-285-10
	TM 5-6115-596-14
<u>Materials/Parts</u>	TM 9-1005-213-10
Cleaning compound (WP 0104 00, Item 6)	TM 9-1010-230-10
Lens cleaning solution (WP 0104 00, Item 16)	TM 9-1015-250-10
Cloth (WP 0104 00, Item 7)	TM 9-1220-248-10
Detergent (WP 0104 00, Item)	TM 9-1220-249-10
Grease (WP 0104 00, Item 10)	TM 9-6115-664-13&P
Hydraulic Fluid, Fire Resistant (WP 0104 00, Item 10.2)	TM 11-5820-401-10-2
Lubricating Oil, Engine (WP 0104 00, Item 11.1)	TM 11-5820-498-12
Lubricating Oil, General Purpose (WP 0104 00, Item 11.2)	TM 11-5820-890-10-8
Lubricating Oil, Gear (WP 0104 00, Item 11.3)	TM 11-5830-263-10
Wiping rag (WP 0104 00, Item 15)	TM 11-5965-286-14
	TM 11-5855-311-12&P
<u>Personnel Required</u>	DA Form 2404
Commander	DD Form 2026
Driver	
Gunner	<u>Equipment Condition</u>
Generator Operator	Engine Stopped (WP 0024 00)

SCOPE

This section details preventive maintenance checks and services (PMCS), including lubrication instructions, required for the carrier. Your PMCS table has been provided so you can keep your equipment in good operating condition and ready for its primary mission.

MAINTENANCE FORMS AND RECORDS

Every mission begins and ends with paperwork. There isn't much of it, but you have to keep it up. The forms and records you fill out have many uses. They are a permanent record of the services, repairs, and changes made to your carrier. They are reports to unit maintenance and to your track commander. They are checklists that tell you whether those faults have been repaired. For information on forms and records, see DA PAM 750-8.

WARNINGS AND CAUTIONS

Always observe the WARNINGS and CAUTIONS appearing in your PMCS table BEFORE, DURING, and AFTER you operate the equipment. The WARNINGS and CAUTIONS appear before certain procedures. You must observe these WARNINGS and CAUTIONS to prevent serious injury to yourself and others or to prevent your equipment from being damaged.

EXPLANATION OF TABLE ENTRIES

Item Number Column — Numbers in this column are for reference. When completing DA Form 2404 (Equipment Inspection and Maintenance Worksheet), include the item number for the check/service indicating a fault. Item numbers also appear in the order that you must do checks and services for the intervals listed.

Interval Column — This column tells you when you must do the procedure in the *PROCEDURE* column.

BEFORE procedures must be performed prior to the equipment leaving its containment area or performing its mission. DURING checks are performed by the track commander/driver/gunner per the PMCS table to monitor and identify faults in equipment performance during the mission.

AFTER procedures are performed per the PMCS table at the conclusion of the mission to identify and correct faults which will preclude the next mission.

WEEKLY procedures are performed once each week. WEEKLY as well as BEFORE PMCS procedures must be performed if:

You are the assigned crewmember and have not operated the carrier since the last WEEKLY.

You are operating the carrier for the first time.

When a check or service procedure is required for both WEEKLY and BEFORE intervals, it is not necessary to do the procedure twice.

MONTHLY procedures are performed each month.

SEMI-ANNUALLY procedures are performed every six months or every 1500 miles.

Man-hour Column — Man-hours required to complete all prescribed lubrication are shown to the nearest tenth of an hour.

Item To Be Checked or Serviced Column — This column lists the item to be checked or serviced.

Crewmember/Procedure Column — This column gives the procedure you must do to check or service the item listed in the *ITEM TO BE CHECKED OR SERVICED* column to know if the equipment is ready or available for its intended mission or for operation. You must do the procedure at the time stated in the *INTERVAL* column. Carefully follow these instructions. If you do not have the tools, or if the procedure tells you to, have unit maintenance do the work.

Equipment Not Ready/Available If: Column — Information in this column tells you what faults will keep your equipment from being capable of performing its primary mission. If a check/service finds faults listed in this column, do not operate the equipment. Follow standard operating procedures for maintaining the equipment or reporting equipment failure.

If you find something wrong when performing PMCS, fix it if you can by using Troubleshooting Procedures (WP 0089 00) or maintenance procedures. Notify unit maintenance if you can't fix it.

PMCS GENERAL INSTRUCTIONS**Tools/Materials**

When you do your PMCS, take along the tools you will need to make all the checks. You will always need wiping rags.

Basic Issue Items

Tools and equipment that you need to use when you drive or maintain your carrier are listed in WP 0102 00. These items are issued with the carrier, and they must be turned in with the carrier. Keep them on your carrier at all times. You can't take proper care of the carrier without the basic issue items, so keep them clean and in good shape. Don't use the tools for jobs they are not designed to do. You won't get the job done right, and you could break the tools.

Expendable/Consumable Maintenance Supplies

Supplies that you need to take care of your carrier are listed in WP 0104 00. These supplies are items that you normally will use up or wear out when you use them. Maintenance supplies work for you. Try to get the most out of them.

Cleaning

Keep the carrier clean. Dirt, grease, oil, and debris only get in the way, and may cover up a serious problem. Clean your carrier as you work and as needed. If you clean the carrier or weapons, be sure to observe all information in the following paragraph.

WARNING



Benzene (benzol), paint thinner, gasoline, and diesel fuel oil can burn, poison soldiers, and damage equipment.

Use the approved cleaning agents.

CAUTION

Steam, water, or air under pressure can damage sighting and fire control equipment gears and bearings.

CAUTION

Water entering engine exhaust system can damage engine. Do not allow water to enter engine exhaust system.

CAUTION

Petroleum products will damage rubber that is not resistant to petroleum. Do not get petroleum products on rubber parts.

Use cleaning compound (WP 0104 00, Item 6) on all metal surfaces. Use soap and water when you clean rubber or plastic surfaces. Use clean water or lens cleaning solution (WP 0104 00, Item 16) when you clean optical surfaces.

General Inspection

Hardware: Check bolts, nuts, and screws for looseness and missing, bent, or broken parts. If you find a loose one, tighten it. If you can't tighten it, notify unit maintenance. Look for chipped paint, bare metal, or rust around bolt heads.

Welds: Look for loose or chipped paint, rust, cracks, or gaps where parts are welded together. If you find a bad weld, notify unit maintenance.

Electrical Wires and Connectors: Look for cracked or broken insulation, bare wires, and loose or broken connectors. Tighten loose connectors. Make sure wires are in good shape. If you find cracked or broken insulation, bare wires, or broken connectors, notify unit maintenance.

Straps: Look for rubber hold-down straps that are cracked, broken, or hardened. Look for webbing stowage straps that are frayed, worn, or have missing metal ends. If you find any bad straps, notify unit maintenance.

Hoses and Fluid Lines: Look for wear, damage, and leaks. Make sure clamps and fittings are tight. Wet spots show leaks. A stain around a fitting or connector can also mean there is a leak. If a leak comes from a loose fitting or connector, tighten each fitting or connector. If something is broken or worn out, notify unit maintenance.

Fluid Leaks

You need to know how fluid leaks affect your carrier. Definitions of the types and classes of leaks are given below. You need to know them to determine the condition of your carrier. Learn them. REMEMBER: WHEN IN DOUBT, NOTIFY UNIT MAINTENANCE!

NOTE

You are allowed to operate equipment with minor leaks (Class I or II). How much fluid each item or system being checked or inspected can hold must be considered. When in doubt, notify unit maintenance. When operating equipment with Class I or II leaks, continue to check fluid levels as required in your PMCS. Report Class III leaks to unit maintenance for corrective action right away.

Any fuel leak will make the carrier NOT READY/AVAILABLE.

CLASS I	Seepage of fluid is not great enough to form drops, but is shown by wetness or color changes.
CLASS II	Leakage of fluid is great enough to form drops, but drops do not drip from the item being checked or inspected.
CLASS III	Leakage of fluid is great enough to form drops that fall from the item being checked or inspected.

LUBRICATION

Service Intervals — Normal Conditions

For safer, more trouble-free operation, see to it that your carrier is serviced when it needs it.

Service Intervals — Unusual Conditions

Your carrier will often need extra service and care when you operate under unusual conditions. High or low temperatures, long periods of hard use, continued use in sand, water, mud, or snow, will break down the lubricant. Then you have to add or change lubricant more often. But during periods when the carrier isn't used, the service intervals can be stretched out.

Army Oil Analysis Program (AOAP)

AOAP is an effective maintenance diagnostic tool and is not a maintenance substitute. TB 43-0211 must not be interpreted to mean AOAP minimizes, in any way, the need to employ good maintenance practices and strong maintenance disciplines.

Sampling Requirements: Samples may be taken without WARMING a component to operating temperature if equipment has been operated within the last 30 days. If equipment has not been operated within the last 30 days, the component must be brought to operating temperature. These requisites apply to both routine and special sampling. Oil samples must not be taken immediately after oil is added. When oil sampling valve is not available to take oil sample, use a vampire pump.

Frequency of AOAP Sample: Every 60 days obtain samples of engine and transmission oil and send to the nearest AOAP Laboratory (TB 43-0211). Take samples as near the prescribed interval as possible. If sampling at the prescribed interval is not possible, a 10 percent variance before or after the scheduled interval date or miles is permissible. The need for on-condition oil changes will be determined by the AOAP Laboratory.

NOTE

If AOAP laboratory support is not available, notify unit maintenance to drain oil and change filter element/gasket every 1,500 miles or semi-annually. The hard time interval may be shortened if equipment is operated under adverse conditions.

Engine and transmission filters need to be replaced every 150 hours/1,500 miles or semi-annually, even when following AOAP procedures.

Sampling Procedures:

1. Perform DAILY operation checks and services.

NOTE

DO NOT ADD OIL immediately prior to taking oil samples. When operation checks and services indicate the need to replenish oil levels, **WAIT** until after taking samples. New oil added immediately prior to taking samples or before prolonged operation of components will adversely affect oil analysis results.

2. Obtain two sample bottles (NSN 8125-01-082-9697) and two DD Form 2026s from the unit AOAP monitor.
3. Start engine (WP 0021 00). If required (refer to Sampling Requirements paragraph), operate carrier to bring engine and transmission up to normal operating temperatures.
4. Stop carrier and set the brakes.
5. Place range selector in SL position (steering lock) and keep engine running.
6. Remove driver's power plant access panel (WP 0040 00).
7. With engine running, remove dust caps from engine and transmission oil sampling valves.

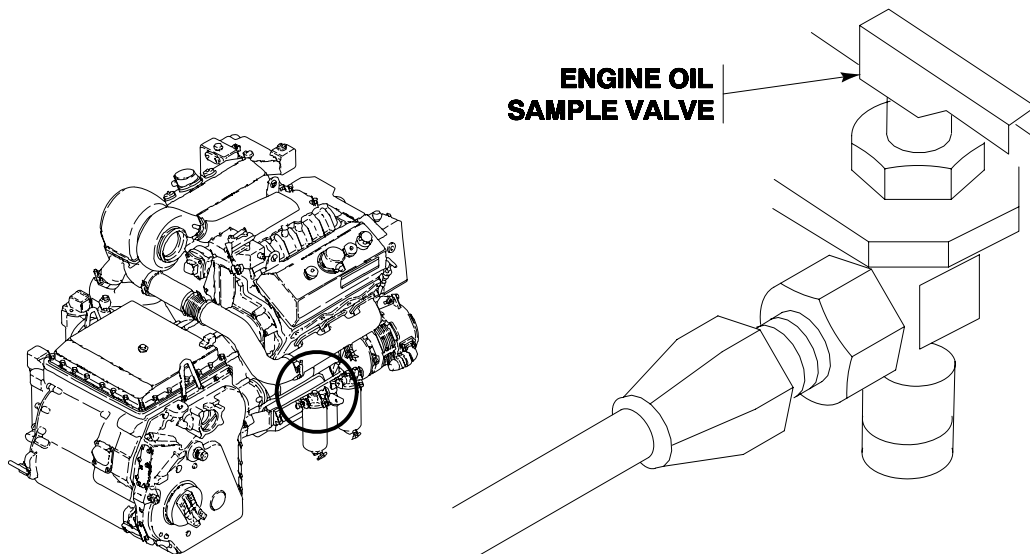

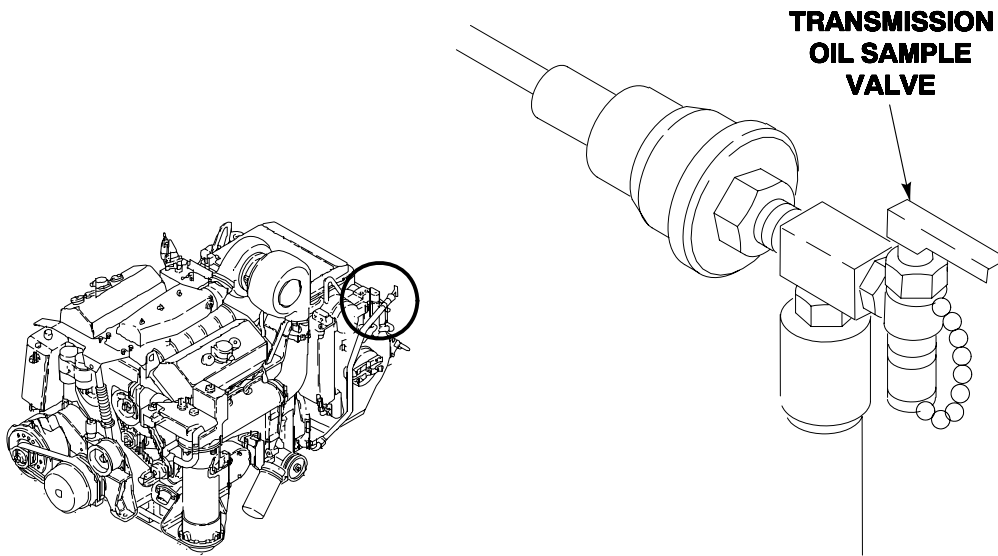

8. Open sampling valve on engine oil filter and drain a small amount of oil into a container to clear valve of grit and contamination. (Properly dispose of container and oil upon completion of sample taking.) Fill sampling bottle to the neck shoulder and seal it. Attach DD Form 2026 to sample bottle.



9. Close oil sample valve and install dust cap.
10. Take oil sample from transmission in the same manner (Steps 7 - 9).
11. Stop engine (WP 0024 00).
12. Install driver's power plant access panel (WP 0040 00) and secure carrier.
13. Deliver sample bottles to unit AOAP monitor.

NOTE

For location of nearest AOAP Laboratory and complete information about AOAP, refer to TB 43-0211.

Preservation Oil

If engine/transmission has been filled with preservation engine oil, leave this oil in engine/transmission until first scheduled oil change. Maintain operating oil level by adding applicable grade oil (OE/HDO or OEA). When first scheduled oil change is due, notify unit maintenance to refill engine/transmission with applicable grade oil. See Lubrication Tables.

Lubrication Tables

The following tables provide lubrication data for the PMCS lubrication checks.

Table 1. LUBRICANT SYMBOLS

SYMBOL	NOMENCLATURE	SPECIFICATION
DF	Diesel Fuel	A-A-52557
FRH	Hydraulic Fluid, Rust Inhibited, Fire Retardant	MIL-PRF-46170
GAA	Grease, Automotive and Artillery	MIL-PRF-10924
	Grease, Wire Rope and Exposed Gear	MIL-PRF-18458
OE/HDO	Lubricating Oil, Internal Combustion Engine	MIL-PRF-2104
OEA	Lubricating Oil, Internal Combustion Engine	MIL-PRF-46167
PE	Preservation Oil	MIL-PRF-21260
PL-M	Lubricating Oil, General Purpose (Medium)	MIL-PRF-3150
PL-S	Lubricating Oil, General Purpose (Special)	SAE J2360

Table 2. LUBRICANT USAGE

COMPONENTS	CAPACITIES (APPROX)	LUBRICANTS TO USE AT EXPECTED TEMPERATURES*			INTERVALS
		ABOVE 32°F (ABOVE 0°C)	+40°F TO -10°F (+5°C TO -23°C)	0°F TO -65°F (-18°C TO -54°C)	
Engine	18 qts.	OE/HDO-15/40	OE/HDO-15/40	OEA	Daily - Check and Fill On Condition - Sample
		PE-30-1	PE-30-1		Leave in engine until first scheduled oil change
Fuel System M113A3, M1059A3, M1064A3, M58	95 gal	DF-2	DF-1	DF-A	Daily - Drain filters
Fuel System M577A3, M1068A3	120 gal	DF-2	DF-1	DF-A	Daily - Drain filters

PREVENTIVE MAINTENANCE CHECKS AND SERVICES — Continued

0090 00

COMPONENTS	CAPACITIES (APPROX)	LUBRICANTS TO USE AT EXPECTED TEMPERATURES*			INTERVALS
		ABOVE 32°F (ABOVE 0°C)	+40°F TO -10°F (+5°C TO -23°C)	0°F TO -65°F (-18°C TO -54°C)	
Transmission	Initial fill - 12 gal or 48 qts <u>Refill after oil change</u> - approx 36 qts	OE/HDO-15/40	OE/HDO-15/40	OEA	Daily - Check and Fill On Condition - Sample
		PE-10-1	PE-10-1		Leave in transmission until first scheduled oil change
Ramp System	3 1/2 qts or 7 pints	FRH			Daily - Check and Fill
Final Drives	3 1/2 qts or 7 pt (FULL mark on gauge rod)	OE/HDO-15/40	OE/HDO-15/40	OEA	Weekly - Check and Fill
Fan Gearbox	18 oz or 3/4 pt	OE/HDO-15/40	OE/HDO-15/40	OEA	Monthly - Check and Fill
Tow Cable	As required	Grease MIL-PRF-18458			Semi-annually or every 1500 miles - Clean and Lube
Ramp Wire Rope	As required	Grease MIL-PRF-18458			Semi-annually or every 1500 miles - Clean and Lube
Machine Gun Mount	As required	PL-M	PL-M	PL-S	Semi-annually or every 1500 miles - Clean and Lube

*For arctic operation, refer to FM 9-207.

Table 3. Preventive Maintenance Checks and Services for Model M113A3 FOV, Before

ITEM NO.	INTERVAL	MAN-HOUR	ITEM TO BE CHECKED OR SERVICED	CREWMEMBER PROCEDURE	EQUIPMENT NOT READY/ AVAILABLE IF:
1	Before		Carrier Exterior	<p style="text-align: center;">WARNING</p> <div style="text-align: center;">  </div> <p>Failure to set parking brake and block wheels can allow carrier to move and could result in personnel injury or death. Always set parking brake and block wheels before performing PMCS.</p> <p style="text-align: center;">NOTE</p> <p>Perform your WEEKLY as well as BEFORE PMCS if: You are the assigned operator but have not operated the carrier since your last weekly inspection or you are operating the carrier for the first time.</p> <p>THINK SAFETY Inspect and work safely. Protect yourself and your crew members. Read and observe all warnings.</p> <p>DRIVER</p> <p>a. Walk around vehicle, check for leaks, tampering, damage, or missing parts.</p>	Any Class III leak or fuel leak identified. Any damage that would prevent operation.

ITEM NO.	INTERVAL	MAN-HOUR	ITEM TO BE CHECKED OR SERVICED	CREWMEMBER PROCEDURE	EQUIPMENT NOT READY/ AVAILABLE IF:
2	Before		Auxiliary Power Unit (APU) (M577A3 and M1068A3)	DRIVER a. See TM 9-6115-664-13&P for PMCS procedures.	Fault listed in "NOT FULLY MISSION CAPABLE IF:" column of APU TM.
3	Before		Track Tension	DRIVER <div style="text-align: center;"> <hr style="width: 100px; margin: 0 auto;"/> <p>WARNING</p> <hr style="width: 100px; margin: 0 auto;"/>  <p>Not having the correct track tension during inspection can cause you to not see defective track parts that could cause track failure and loss of vehicle control. Soldiers can be killed or injured.</p> <p>Adjust track tension before inspecting track assembly and track shoes.</p> </div> <div style="text-align: center; margin-top: 20px;"> <p>NOTE</p> <p>Perform adjustment after vehicle is fully loaded.</p> </div> a. Adjust track tension as necessary (T130) (WP 0091 00) or (T150) (WP 0091 00).	

PREVENTIVE MAINTENANCE CHECKS AND SERVICES — Continued

0090 00

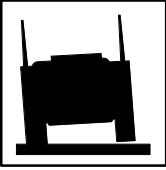
ITEM NO.	INTERVAL	MAN-HOUR	ITEM TO BE CHECKED OR SERVICED	CREWMEMBER PROCEDURE	EQUIPMENT NOT READY/ AVAILABLE IF:
4	Before		Track Shoes and Bushings (T150 Track Only)	<p>DRIVER</p> <p style="text-align: center;">WARNING</p>  <p>If you lose a track (break a track shoe or vehicle throws a track), extreme caution must be exercised in maintaining control. Immediately release accelerator and let the vehicle coast to a stop. Do not apply braking action, i.e., brake pedal, pivot, or any type of steering controls. This causes the vehicle to pull to the active or good track and could result in a rollover. It is absolutely necessary to apply braking action only, and we stress only, if the vehicle is approaching a ravine, a cliff, or if you perceive the outcome to be catastrophic, probably resulting in fatalities. When a rollover is imminent, all crewmembers should immediately withdraw inside the vehicle, tighten seat belts and hold onto a secure fixture, until the vehicle comes to a complete stop.</p>	

ITEM NO.	INTERVAL	MAN-HOUR	ITEM TO BE CHECKED OR SERVICED	CREWMEMBER PROCEDURE	EQUIPMENT NOT READY/ AVAILABLE IF:
				<p style="text-align: center;">WARNING</p> <div style="text-align: center;">  </div> <p>Failure to perform track PMCS and not repair or report to maintenance per technical manual procedures can allow you to operate the vehicle with defective track parts that could cause track failure and loss of vehicle control. Soldiers can be killed or injured.</p> <p>Never operate a vehicle without performing the BEFORE mission PMCS track tension adjustment and track inspection per PMCS procedures in the technical manual. Repair or report problems to maintenance per technical manual instructions as outlined in PMCS.</p> <p style="text-align: center;">NOTE</p> <p>Move carrier one track length to inspect entire track.</p> <ol style="list-style-type: none"> a. Check for any broken track shoes (cracked or broken shoe body) bent, broken, or missing center guides, chunked or missing road wheel path. If one or more track shoes or three or more center guides in a row are broken, notify unit maintenance. b. Check center guide wear. Use track wear gauge (WP 0102 00, Item 24A). If three or more center guides in a row show excessive wear, notify unit maintenance. 	<p>One or more broken track shoes. Three or more broken center guides in a row.</p> <p>Three or more center guides in a row show excessive wear.</p>

ITEM NO.	INTERVAL	MAN-HOUR	ITEM TO BE CHECKED OR SERVICED	CREWMEMBER PROCEDURE	EQUIPMENT NOT READY/ AVAILABLE IF:
				<p style="text-align: center;">NOTE</p> <p>Worn or missing track shoe pads will cause track shoe to wear out prematurely and mark road surface.</p> <p>c. Check track shoe for worn or missing track pads/pad nuts.</p>	

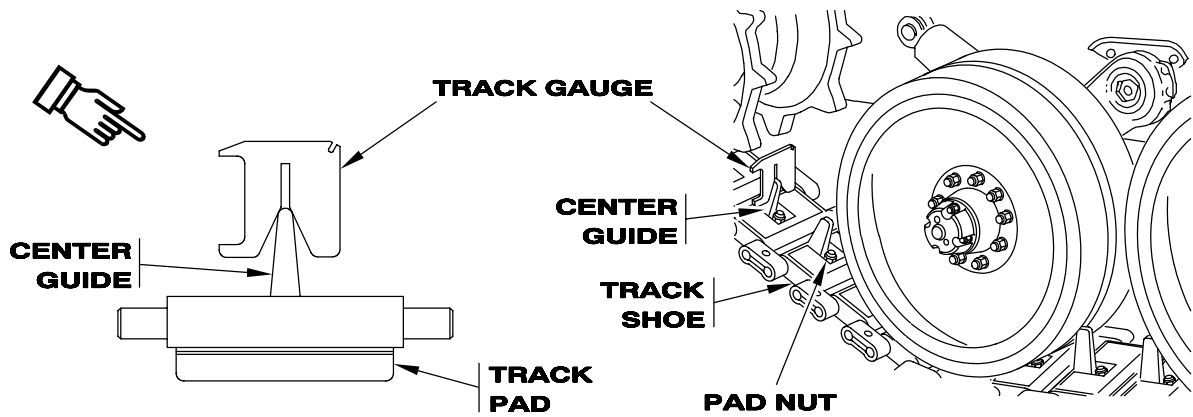

				<p>d. Check track shoe for missing, or loose end connectors/bolts. Tighten loose end connectors. If one or more end connectors or bolts is missing, notify unit maintenance.</p>	<p>One or more end connectors/bolts missing.</p>
--	--	--	--	--	--

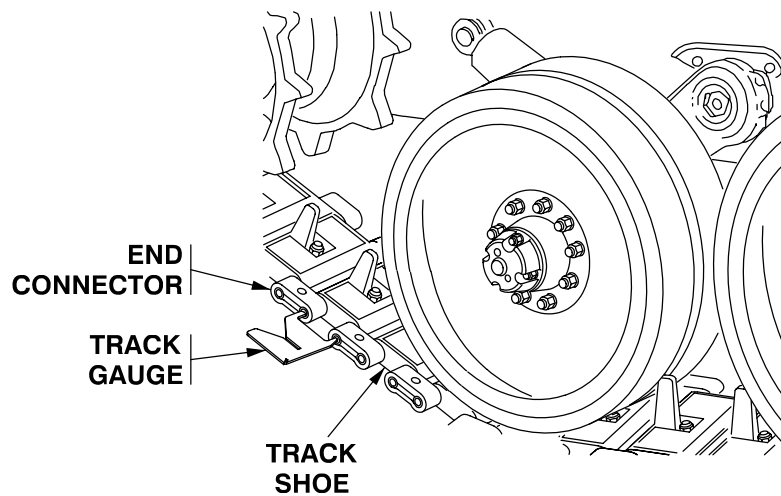

PREVENTIVE MAINTENANCE CHECKS AND SERVICES — Continued

0090 00

ITEM NO.	INTERVAL	MAN-HOUR	ITEM TO BE CHECKED OR SERVICED	CREWMEMBER PROCEDURE	EQUIPMENT NOT READY/ AVAILABLE IF:
5	Before		T150 Track Shoe End Connector Bolt	<p>e. Check for track pin bushing wear. Use track wear gauge when worn bushings are visible (WP 0102 00, Item 24A). If track wear gauge does not move freely inside track pin, notify unit maintenance.</p> <p>DRIVER</p> <p>a. All new installed T150 track shoes require to be checked between 30 and 80 miles of use. END CONNECTOR BOLTS NEED TO BE RETORQUED TO 400-430 LB-FT (543-583 N·M) TORQUE. Notify unit maintenance.</p>	Track wear gauge does not move freely inside track pin.

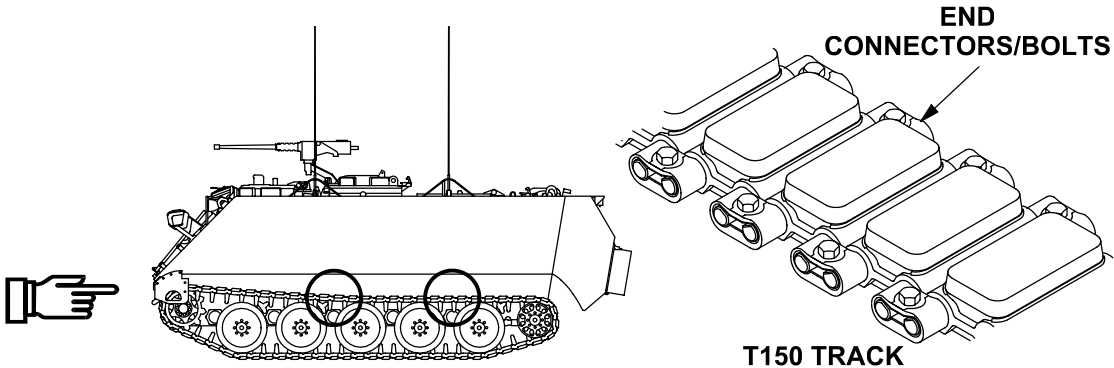

PREVENTIVE MAINTENANCE CHECKS AND SERVICES — Continued

0090 00

ITEM NO.	INTERVAL	MAN-HOUR	ITEM TO BE CHECKED OR SERVICED	CREWMEMBER PROCEDURE	EQUIPMENT NOT READY/ AVAILABLE IF:
6	Before		Track Shoes and Bushings (T130 Track Only)	<p>DRIVER</p> <p style="text-align: center;">WARNING</p>  <p>Failure to perform track PMCS and not repair or report to maintenance per technical manual procedures can allow you to operate the vehicle with defective track parts that could cause track failure and loss of vehicle control. Soldiers can be killed or injured.</p> <p>Never operate a vehicle without performing the BEFORE mission PMCS track tension adjustment and track inspection per PMCS procedures in the technical manual. Repair or report problems to maintenance per technical manual instructions as outlined in PMCS.</p>	

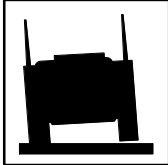
ITEM NO.	INTERVAL	MAN-HOUR	ITEM TO BE CHECKED OR SERVICED	CREWMEMBER PROCEDURE	EQUIPMENT NOT READY/ AVAILABLE IF:
				<p style="text-align: center;">WARNING</p> <div style="text-align: center;">  </div> <p>If you lose a track (break a track shoe or vehicle throws a track), extreme caution must be exercised in maintaining control. Immediately release accelerator and let the vehicle coast to a stop. Do not apply braking action, i.e., brake pedal, pivot, or any type of steering controls. This causes the vehicle to pull to the active or good track and could result in a rollover. It is absolutely necessary to apply braking action only, and we stress only, if the vehicle is approaching a ravine, a cliff, or if you perceive the outcome to be catastrophic, probably resulting in fatalities. When a rollover is imminent, all crewmembers should immediately withdraw inside the vehicle, tighten seat belts and hold onto a secure fixture, until the vehicle comes to a complete stop.</p> <p style="text-align: center;">NOTE</p> <p>Move carrier one track length to inspect entire track.</p> <p>a. Visually check for unusual or uneven gaps between two adjacent shoes. Check any suspect bushing using the track and sprocket gauge (WP 0102 00, Item 24). If a “NO/GO” reading is obtained on either the inside or outside of the block, the unserviceable shoe/shoes must be replaced.</p>	<p>Any unserviceable shoe.</p>

ITEM NO.	INTERVAL	MAN-HOUR	ITEM TO BE CHECKED OR SERVICED	CREWMEMBER PROCEDURE	EQUIPMENT NOT READY/ AVAILABLE IF:
				<p>b. Check track shoes for damage. Damage includes cracked or broken shoe body, bent, broken, or missing center guides, chunked or missing roadwheel path rubber.</p> <p style="text-align: center;">NOTE</p> <p>Worn or missing track pads will cause the track shoe to mark the road surface.</p> <p>c. Replace worn or missing track pads and track pad nuts.</p>	<p>Any one track shoe body bent, cracked, or broken. Any one track pin bent, broken, or missing.</p>

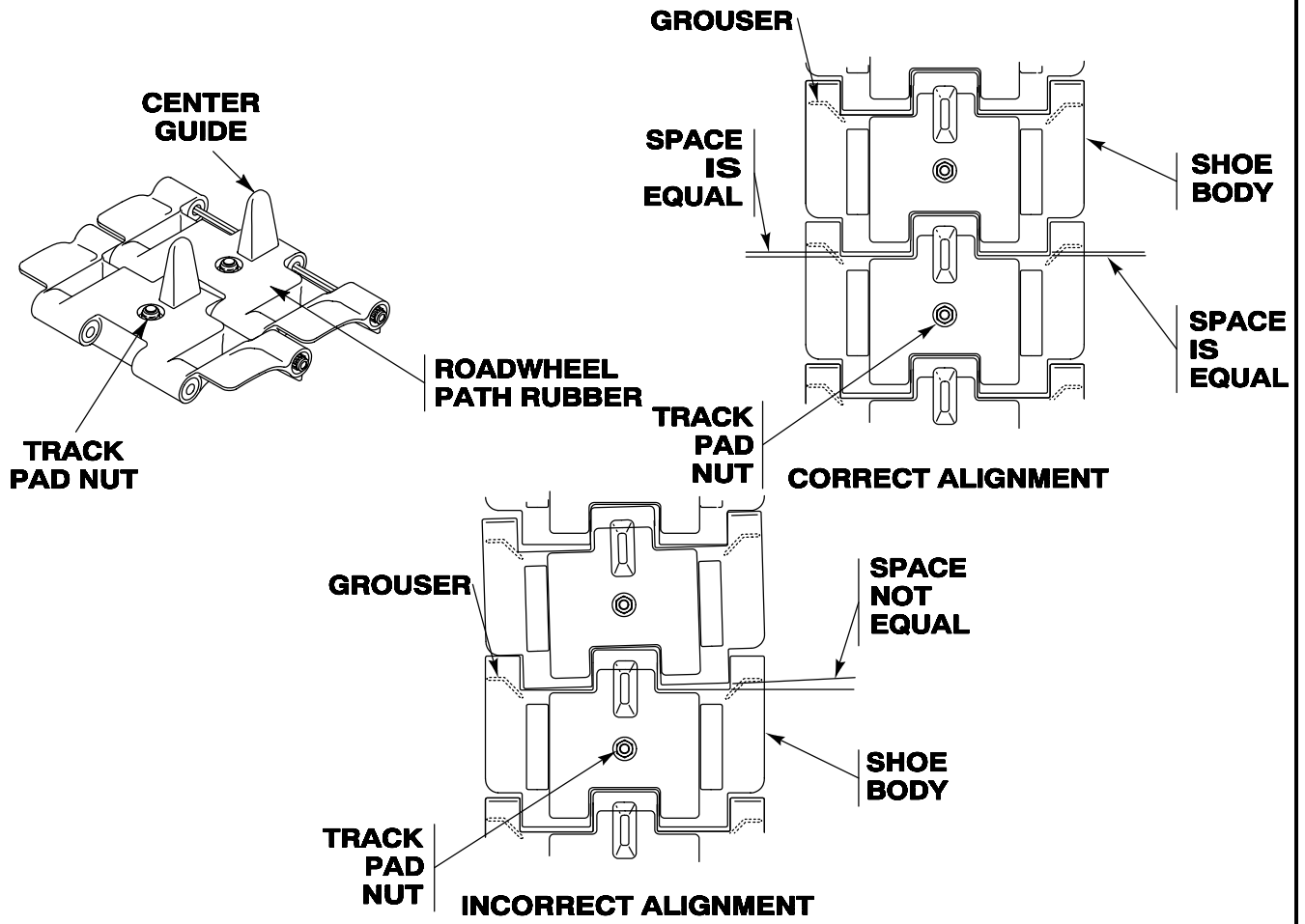

ITEM NO.	INTERVAL	MAN-HOUR	ITEM TO BE CHECKED OR SERVICED	CREWMEMBER PROCEDURE	EQUIPMENT NOT READY/ AVAILABLE IF:
				<p>d. Check track shoe for damaged pins, missing pin nuts, and any unusual or uneven gaps between two adjacent track shoes which indicate worn bushings.</p> <p style="text-align: center;">NOTE</p> <p>Worn bushings are very difficult to locate. Worn bushings may cause the track pin to appear off-center; it may have protruding track pin or track pin nut, unusual gaps between two adjacent shoes.</p>	<p>Any one shoe with worn bushing, protruding track pin, missing track pin nut. Any one bushing deemed unserviceable, pad height is less than 1/16" above grouser.</p>

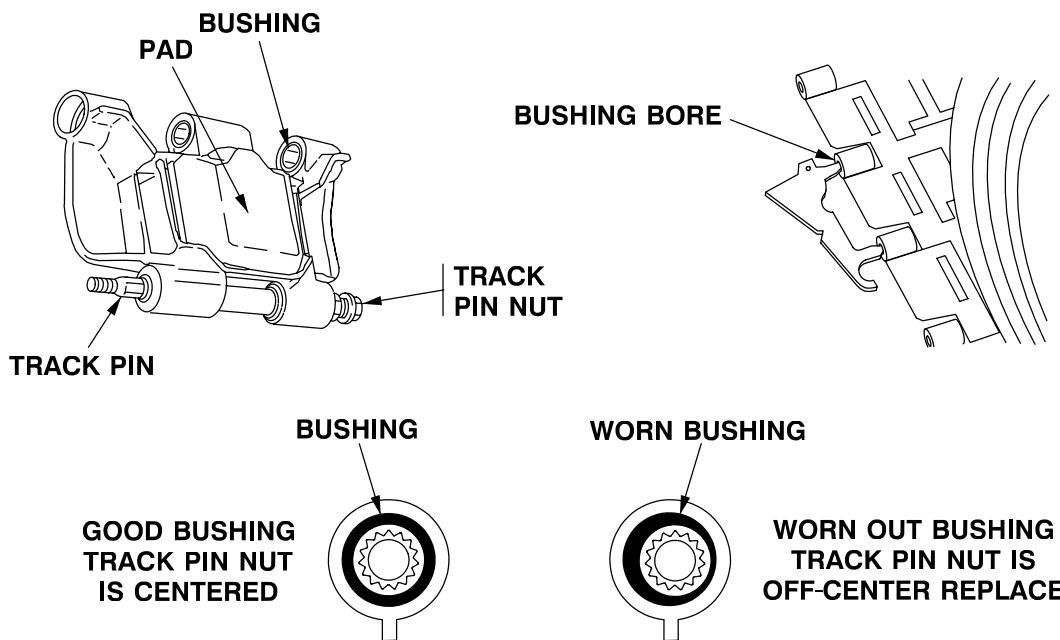

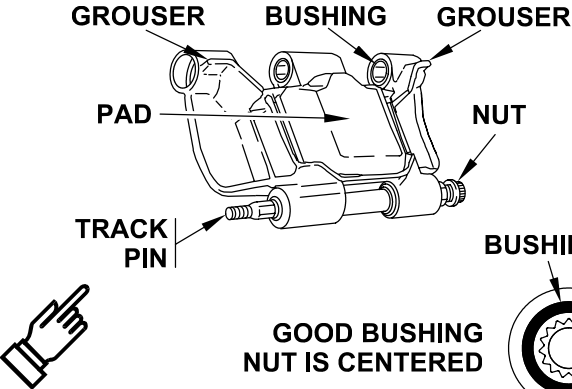
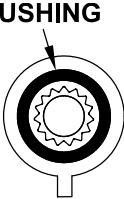
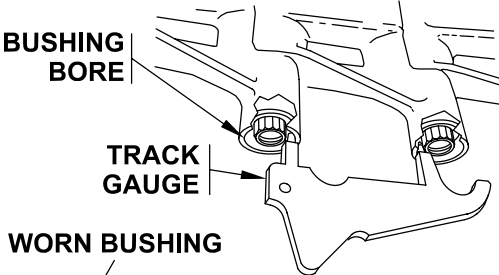
ITEM NO.	INTERVAL	MAN-HOUR	ITEM TO BE CHECKED OR SERVICED	CREWMEMBER PROCEDURE	EQUIPMENT NOT READY/ AVAILABLE IF:
				<p style="text-align: center;">NOTE</p> <p>Check left and right side of vehicle for damage to track shoes.</p> <p>e. Check for any suspect bushings which should be tested with the track and sprocket gauge. Gauge pins must be fully inserted into bushing bore. Any track shoe failing track gauge inspection is unserviceable. Replace any worn shoe bushing with shoe.</p>	<p>Any one track shoe with worn bushing, protruding track pin, or missing track pin nut. Any one bushing deemed unserviceable. Pad height is less than 1/16" above grouser.</p>
<div style="display: flex; justify-content: space-around; align-items: flex-start;"> <div style="text-align: center;">  <p>GOOD BUSHING NUT IS CENTERED</p> </div> <div style="text-align: center;">  <p>WORN BUSHING NUT IS OFF-CENTER REPLACE</p> </div> <div style="text-align: center;">  </div> </div>					

PREVENTIVE MAINTENANCE CHECKS AND SERVICES — Continued

0090 00

ITEM NO.	INTERVAL	MAN-HOUR	ITEM TO BE CHECKED OR SERVICED	CREWMEMBER PROCEDURE	EQUIPMENT NOT READY/ AVAILABLE IF:
7	Before		Carrier Exterior (Ground Level) Final Drive and Hull Plugs	<p>DRIVER</p> <p>a. Check beneath carrier for loose or missing hull access cover and drain plugs (three plugs). Tighten loose hull access cover and drain plugs.</p>	Any Class III leak. One or more hull access covers, drain plugs or seals missing. Any fuel leak.
8	Before		Fire Extinguisher Exterior Pull Handle	<p>COMMANDER</p> <p>a. Check seal on exterior pull handle. Make sure seal or lockwire is not broken. Report broken seal or lockwire to unit maintenance.</p>	Seal or lockwire missing or broken.

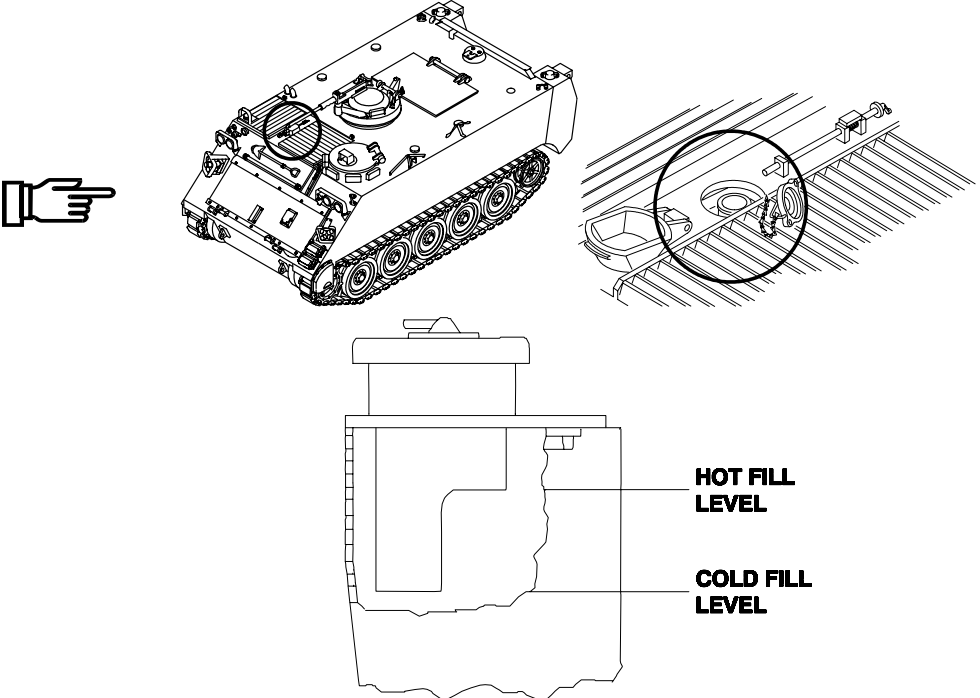

ITEM NO.	INTERVAL	MAN-HOUR	ITEM TO BE CHECKED OR SERVICED	CREWMEMBER PROCEDURE	EQUIPMENT NOT READY/ AVAILABLE IF:
9	Before		Radiator (on deck) Coolant Level	<p>DRIVER</p> <p style="text-align: center;">WARNING</p>  <p>Hot radiator coolant can burn you. Use hand to remove cap only if cool to touch. Turn cap slowly to release pressure. Replace cap by pressing down and turning cap until tight.</p> <p>a. Remove radiator cap. Check coolant level.</p>	Any Class III leak. Cap damaged or missing.



ITEM NO.	INTERVAL	MAN-HOUR	ITEM TO BE CHECKED OR SERVICED	CREWMEMBER PROCEDURE	EQUIPMENT NOT READY/ AVAILABLE IF:
10	Before		Fixed Fire Extinguisher	<p>DRIVER</p> <p style="text-align: center;">WARNING</p> <div style="text-align: center;">  </div> <p>A fire can break out at any time. Personnel could be killed or injured. Equipment could be damaged. Make sure all fire extinguishers are ready to use before you operate carrier.</p> <p style="text-align: center;">CAUTION</p> <p>Inspect cylinder/bottle data to ensure the latest hydrostatic test was performed within the past 5 years. Any bottle/cylinder beyond the test time limit shall be declared unserviceable and replaced.</p> <ol style="list-style-type: none"> a. Inspect fire extinguisher cylinder data plate to ensure that a hydrostatic test has been performed within the past 5 years. Faulty extinguishers or those beyond the test time limit (5 years) shall be declared unserviceable and replaced. b. Check fixed extinguisher control seal. 	<p>If cylinder/ bottles are overdue for a hydrostatic test.</p> <p>Extinguisher missing.</p>

PREVENTIVE MAINTENANCE CHECKS AND SERVICES — Continued

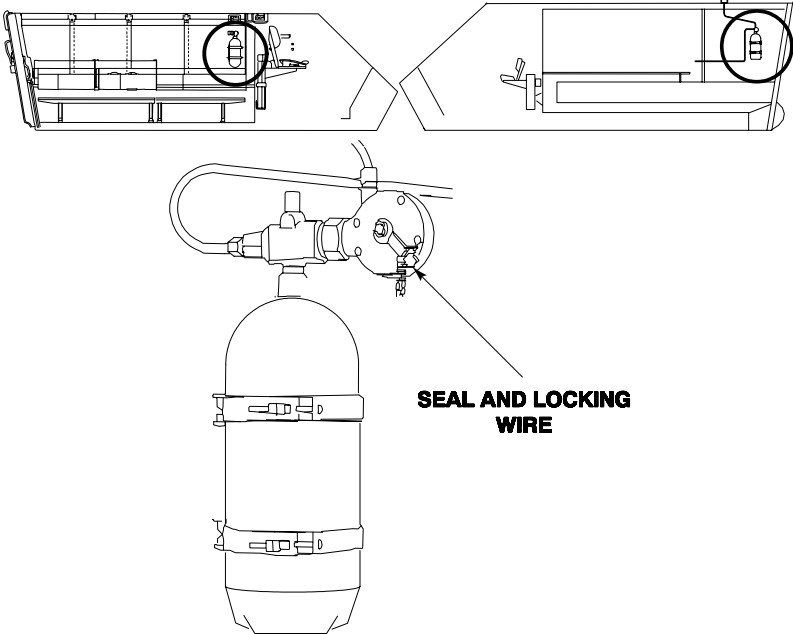
0090 00

ITEM NO.	INTERVAL	MAN-HOUR	ITEM TO BE CHECKED OR SERVICED	CREWMEMBER PROCEDURE	EQUIPMENT NOT READY/ AVAILABLE IF:
11	Before		Portable Fire Extinguishers	<p>c. Make sure seal or lockwire is not broken. Report broken seal to unit maintenance.</p>  <p>SEAL AND LOCKING WIRE</p> <p>CREWMEMBER</p> <p>WARNING</p>  <p>A fire can break out at any time. Personnel could be killed or injured. Equipment could be damaged. Make sure all fire extinguishers are ready to use before you operate carrier.</p>	Seal or lockwire missing or broken.

ITEM NO.	INTERVAL	MAN-HOUR	ITEM TO BE CHECKED OR SERVICED	CREWMEMBER PROCEDURE	EQUIPMENT NOT READY/ AVAILABLE IF:
<p>NOTE</p> <p>On M113A3, portable fire extinguisher is located against curbside rear plate behind spill liner panels.</p> <p>On M577A3, portable fire extinguisher is located against curbside rear plate.</p> <p>On M1064A3, portable fire extinguisher is located against roadside rear plate.</p> <p>On M1068A3, portable fire extinguisher is located against curbside wall next to the map board.</p> <p>On M58, portable fire extinguisher is located against roadside wall between the battery box and the visual tank.</p>					

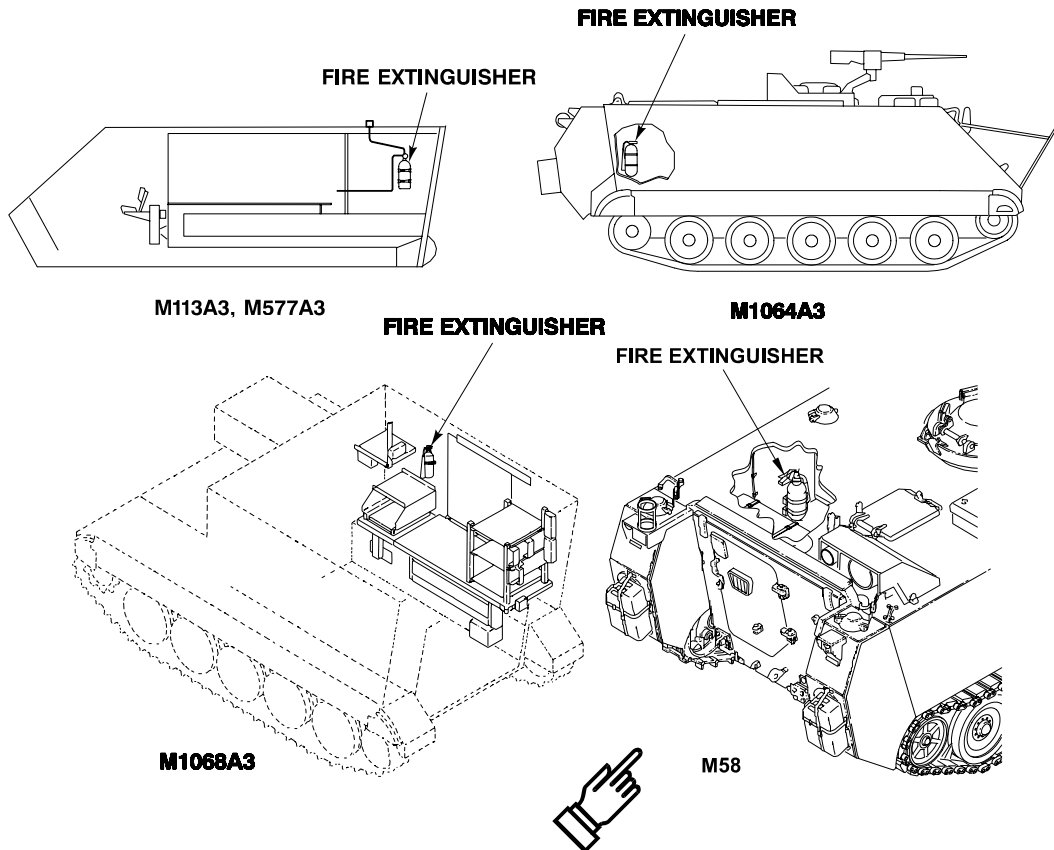

PREVENTIVE MAINTENANCE CHECKS AND SERVICES — Continued

0090 00

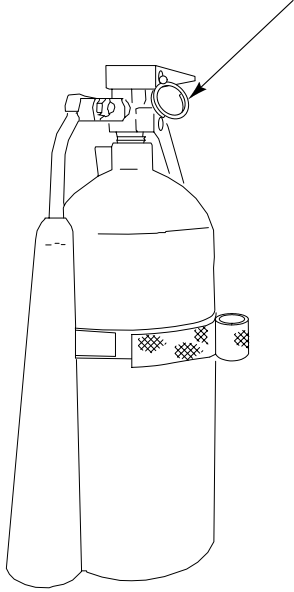
ITEM NO.	INTERVAL	MAN-HOUR	ITEM TO BE CHECKED OR SERVICED	CREWMEMBER PROCEDURE	EQUIPMENT NOT READY/ AVAILABLE IF:
				<ul style="list-style-type: none"> a. Check portable fire extinguisher control seal. Make sure seal or lockwire is not broken. Report broken seal to unit maintenance. b. Check fire extinguisher for security of mounting hardware and missing hardware. c. Check for full charge. 	<p>Fire extinguisher missing. Seal or lockwire missing or broken.</p> <p>Pressure gauge indicates discharge or seal is broken. Extinguisher feels light or seal is broken, if no gauge.</p>
<p>SEAL AND LOCKING PIN</p> 					

PREVENTIVE MAINTENANCE CHECKS AND SERVICES — Continued

0090 00

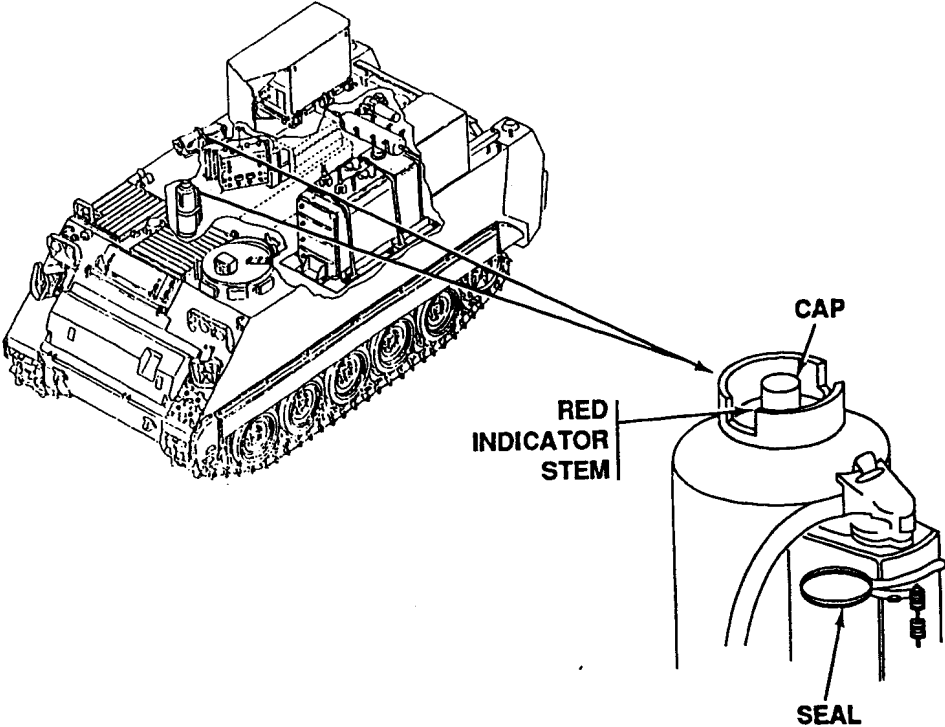
ITEM NO.	INTERVAL	MAN-HOUR	ITEM TO BE CHECKED OR SERVICED	CREWMEMBER PROCEDURE	EQUIPMENT NOT READY/ AVAILABLE IF:
				<p>COMMANDER M1059A3 ONLY</p> <p>d. Check exterior hand-held fire extinguisher seals. Check that red indicator stem on cap is not popped up.</p> <p>e. Check for availability and a full charge.</p>	<p>Fire extinguisher is missing or seal is broken. Red stem popped up.</p> <p>Fire extinguisher is missing or seal is broken.</p>
 <p>The diagram shows a fire extinguisher mounted on the exterior of a vehicle. A callout provides a detailed view of the cap assembly, which includes a 'CAP', a 'RED INDICATOR STEM', and a 'SEAL'.</p>					

PREVENTIVE MAINTENANCE CHECKS AND SERVICES — Continued

0090 00

ITEM NO.	INTERVAL	MAN-HOUR	ITEM TO BE CHECKED OR SERVICED	CREWMEMBER PROCEDURE	EQUIPMENT NOT READY/ AVAILABLE IF:
12	Before		Driver's Instrument Panel and Warning Lights Panel	<p>DRIVER</p> <p>a. Start engine (WP 0021 00). Check that BATT GEN INDICATOR points to green zone.</p> <p>b. Check that TRANS FILTER CLOGGED warning light is off.</p>	<p>Any binding, chattering, or unusual noise. Engine will not start. BATT GEN INDICATOR does not point to green zone. Indicator is missing or broken.</p> <p>Warning light is on, missing or broken.</p>

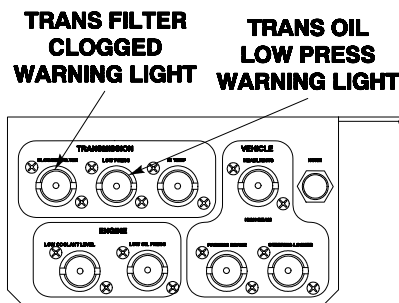
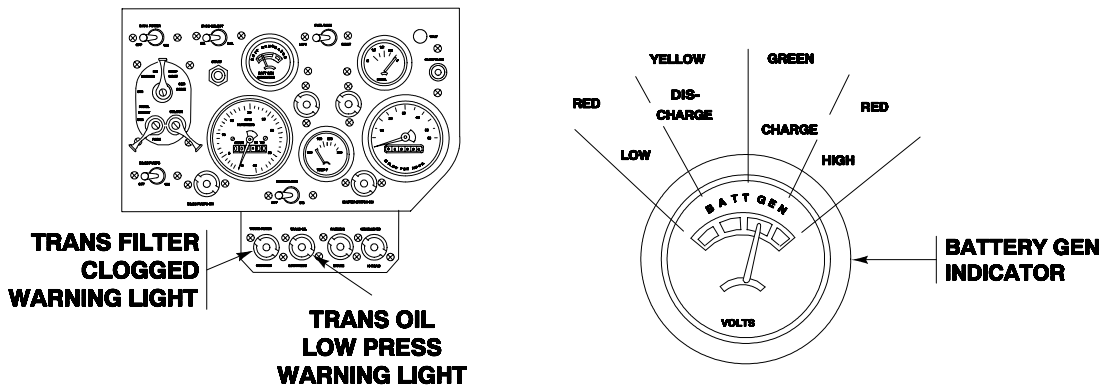

M58 ONLY

ITEM NO.	INTERVAL	MAN-HOUR	ITEM TO BE CHECKED OR SERVICED	CREWMEMBER PROCEDURE	EQUIPMENT NOT READY/ AVAILABLE IF:
				<p style="text-align: center;">CAUTION</p> <p>Do not operate vehicle with the TRANS OIL LOW PRESS warning light on. Operating the vehicle with the TRANS OIL LOW PRESS warning light on can damage the transmission and may result in unpredictable vehicle operation.</p> <p>c. Check that TRANS OIL LOW PRESS warning light is off. Light should go off. Light should go out when engine speed reaches 1200-1300 RPM.</p> <p>d. Check tachometer to see that it is operating properly. Check the idle speed is normal at 650 to 700 RPM.</p> <p>e. Check that ENGINE COOLANT LOW LEVEL warning light is off.</p>	<p>Light does not go out at 1200-1300 RPM.</p> <p>Warning light is on. Light is missing or broken.</p>

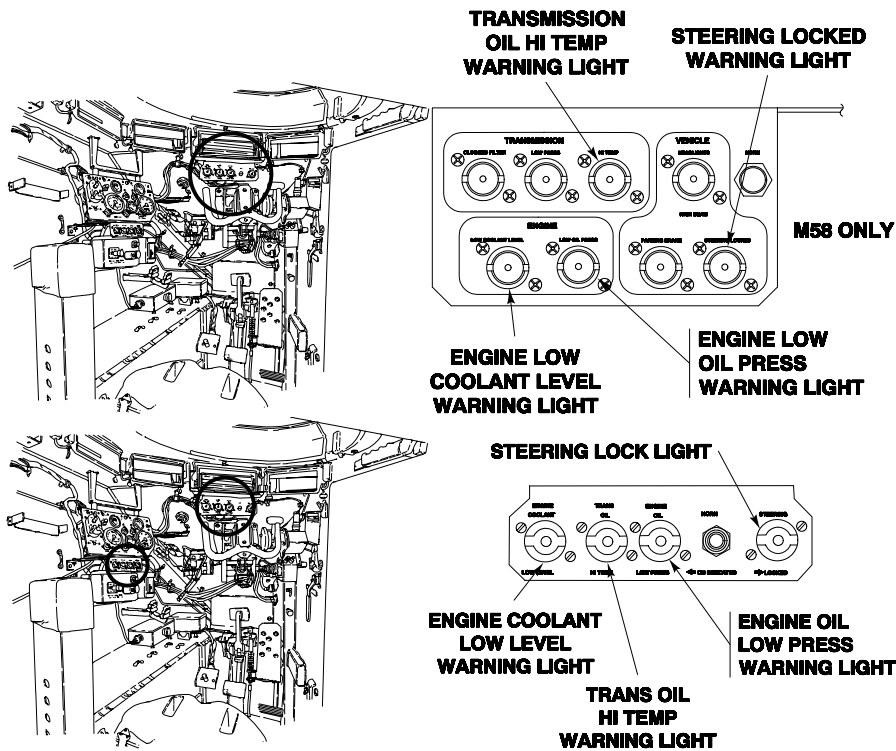

ITEM NO.	INTERVAL	MAN-HOUR	ITEM TO BE CHECKED OR SERVICED	CREWMEMBER PROCEDURE	EQUIPMENT NOT READY/ AVAILABLE IF:
				<p>f. Check that ENGINE OIL LOW PRESS warning light is off.</p> <p>g. Check that TRANS OIL HIGH TEMP warning light is off.</p> <p>h. Check steering lock indicator light is on. Check that steering wheel is locked in locked position.</p>	<p>Warning light is on, missing or broken.</p> <p>Warning light is on, missing, or broken.</p> <p>If steering wheel will not lock in the locked position.</p>

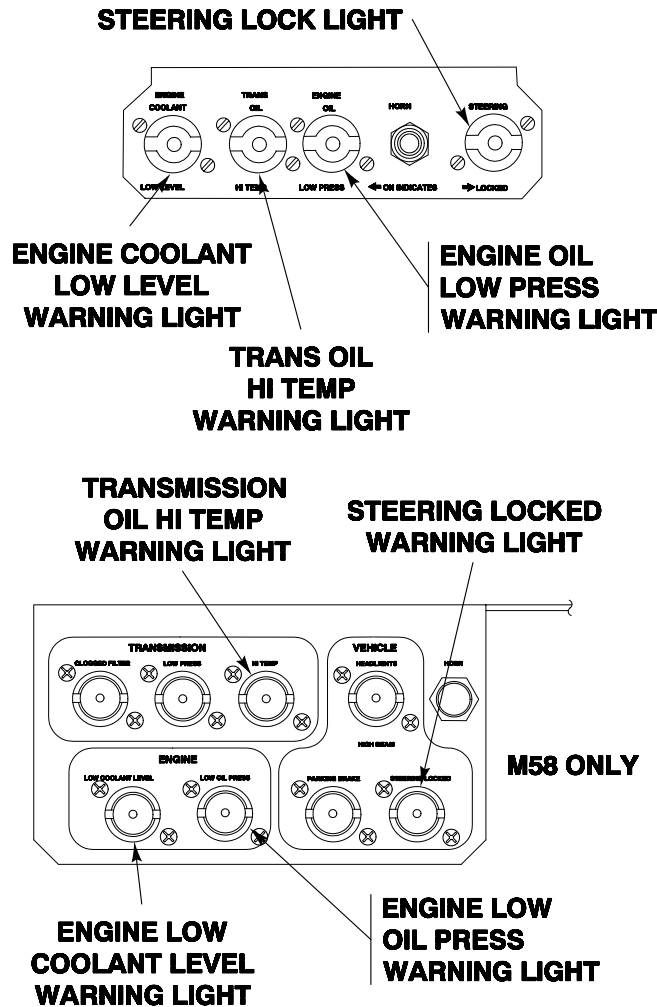

PREVENTIVE MAINTENANCE CHECKS AND SERVICES — Continued

0090 00

ITEM NO.	INTERVAL	MAN-HOUR	ITEM TO BE CHECKED OR SERVICED	CREWMEMBER PROCEDURE	EQUIPMENT NOT READY/ AVAILABLE IF:
				i. Check ENGINE COOLANT TEMPERATURE GAUGE. If outside air temperature is less than 85°F (29°C), normal operating temperature should be 160°F to 200°F (71°C to 93°C). If outside air temperature is greater than 85°F (29°C), normal operating temperature should be 160°F to 225°F (71°C to 107°C). Report any abnormal reading to unit maintenance.	Outside air temperature is less than 85°F (29°C) and gauge is above 200°F (71°C). Outside air temperature is above 85°F (29°C) and gauge is above 225°F (107°C). Gauge is missing or broken.

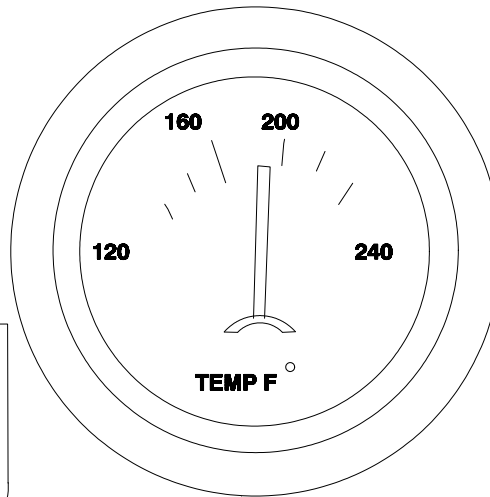
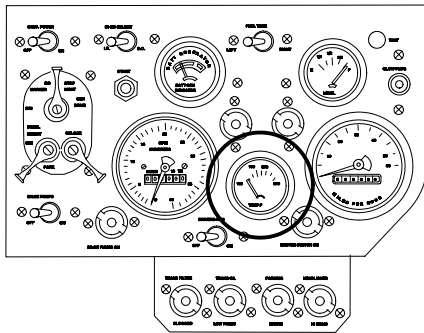

ENGINE COOLANT TEMPERATURE GAUGE

ITEM NO.	INTERVAL	MAN-HOUR	ITEM TO BE CHECKED OR SERVICED	CREWMEMBER PROCEDURE	EQUIPMENT NOT READY/ AVAILABLE IF:
				j. Check warning light panel lights. Watch DIFF OIL HI-TEMP, TRANS OIL HI-TEMP, AND ENGINE OIL HI-TEMP LO PRESS warning lights for red warning.	Any oil warning light comes on.

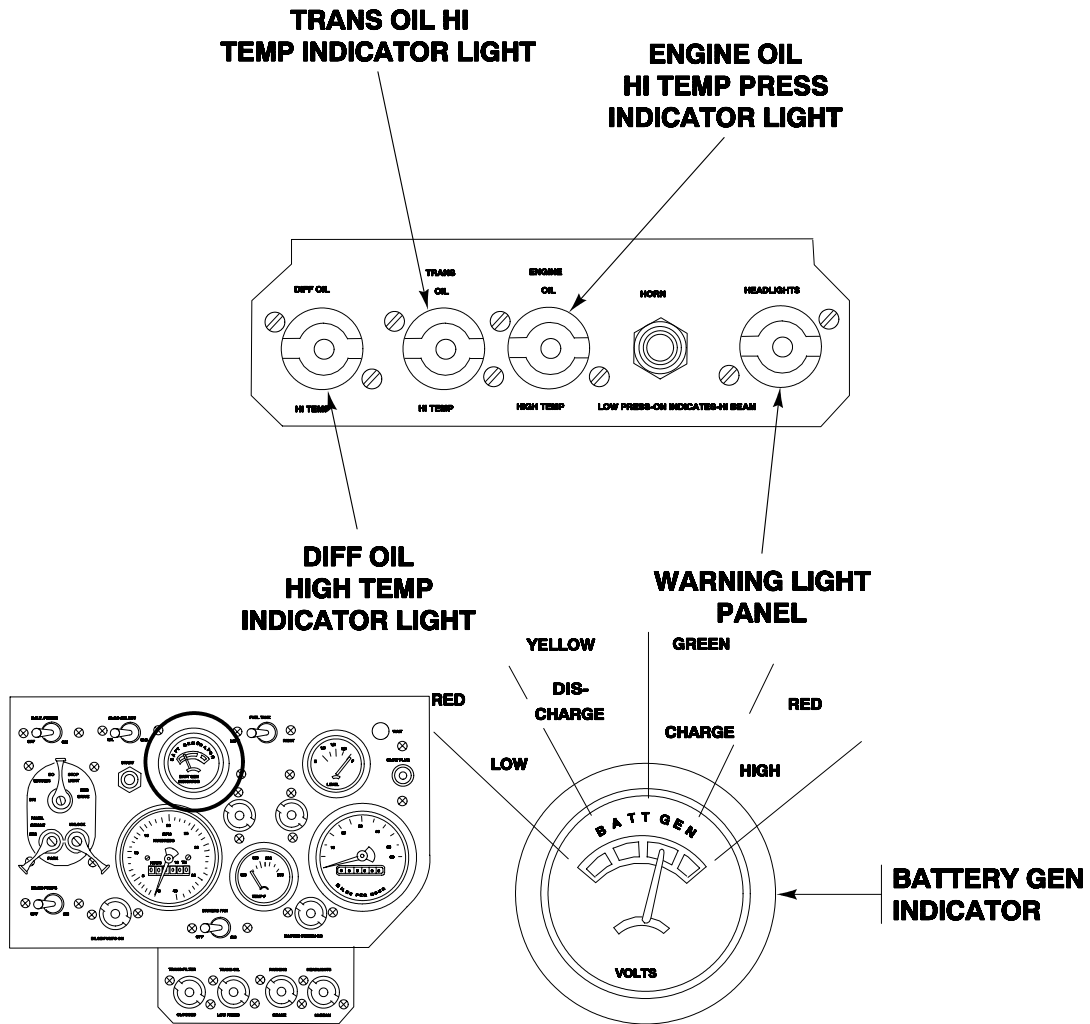

ITEM NO.	INTERVAL	MAN-HOUR	ITEM TO BE CHECKED OR SERVICED	CREWMEMBER PROCEDURE	EQUIPMENT NOT READY/ AVAILABLE IF:
13	Before		Variable Speed Fan Drive Controller	<p>DRIVER</p> <p style="text-align: center;">NOTE</p> <p>Fault indicating lights for Low Coolant Level, ECM Data Link Port, and Fan Brake Active are not used or observed for M113A3 FOV.</p> <p>a. Check variable speed fan controller indicator lights for any faults.</p>	Any faults found (other than coolant level). Report to unit maintenance. If coolant level code is lit, this requires adding water.

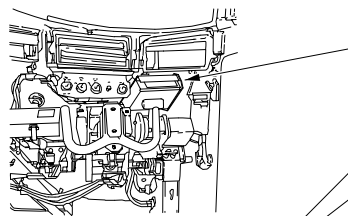

NOTE:
 Fault indicating lights for Low Coolant Level, ECM Data Link Port, and Fan Brake Active are not used or observed for M113A3 FOV.

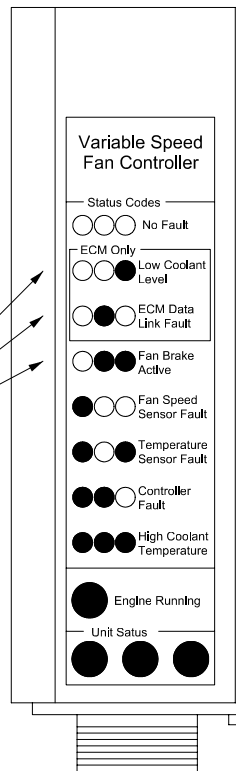

PREVENTIVE MAINTENANCE CHECKS AND SERVICES — Continued

0090 00

ITEM NO.	INTERVAL	MAN-HOUR	ITEM TO BE CHECKED OR SERVICED	CREWMEMBER PROCEDURE	EQUIPMENT NOT READY/ AVAILABLE IF:
14	Before		Ramp	<p>DRIVER</p> <p style="text-align: center;">NOTE</p> <p>Leave ramp lowered to perform before checks.</p> <p>a. Check ramp operation by raising and lowering (WP 0012 00).</p>	Ramp will not raise or lower under power. Ramp lock will not hold ramp in closed position.
15	Before		Ramp Door	<p>DRIVER</p> <p>a. Check ramp door operation. Make sure hinges work right and that door can be tightly secured by lock.</p>	Lock will not secure door. Hinges broken or missing.

ITEM NO.	INTERVAL	MAN-HOUR	ITEM TO BE CHECKED OR SERVICED	CREWMEMBER PROCEDURE	EQUIPMENT NOT READY/ AVAILABLE IF:
16	Before		Throttle Controls	<p>DRIVER</p> <p style="text-align: center;">WARNING</p>  <p>Sticking or damaged linkages can cause carrier to crash. Personnel can be killed or injured. If accelerator pedal does not operate smoothly, or engine does not return to idle when accelerator pedal is released, do not drive carrier.</p> <p>Loss of carrier control can cause carrier to crash. Personnel can be killed or injured. Avoid over steering at high speeds to prevent skidding or carrier upset. Use caution when turning on hills or side slopes.</p> <p>a. Check hand throttle and accelerator pedal operation.</p>	Accelerator pedal or hand throttle binds. Engine does not return to idle when accelerator pedal or hand throttle is released.

PREVENTIVE MAINTENANCE CHECKS AND SERVICES — Continued

0090 00

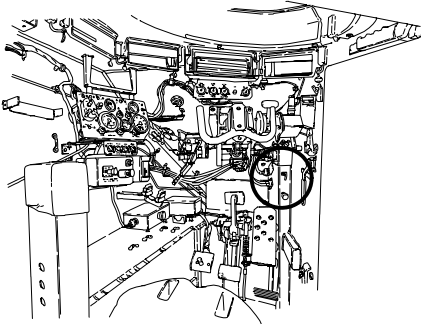
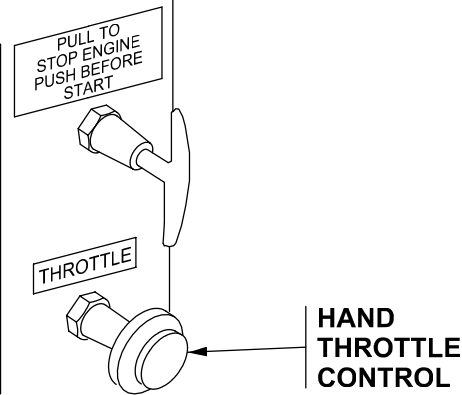
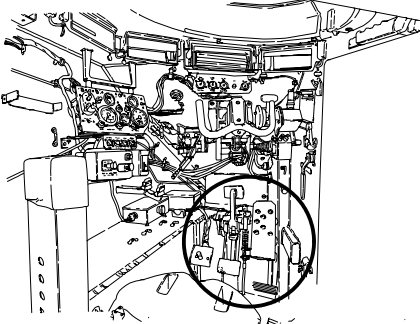
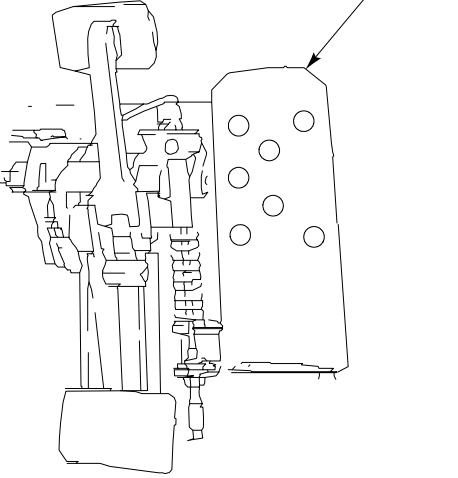
ITEM NO.	INTERVAL	MAN-HOUR	ITEM TO BE CHECKED OR SERVICED	CREWMEMBER PROCEDURE	EQUIPMENT NOT READY/ AVAILABLE IF:
					
					

PREVENTIVE MAINTENANCE CHECKS AND SERVICES — Continued

0090 00

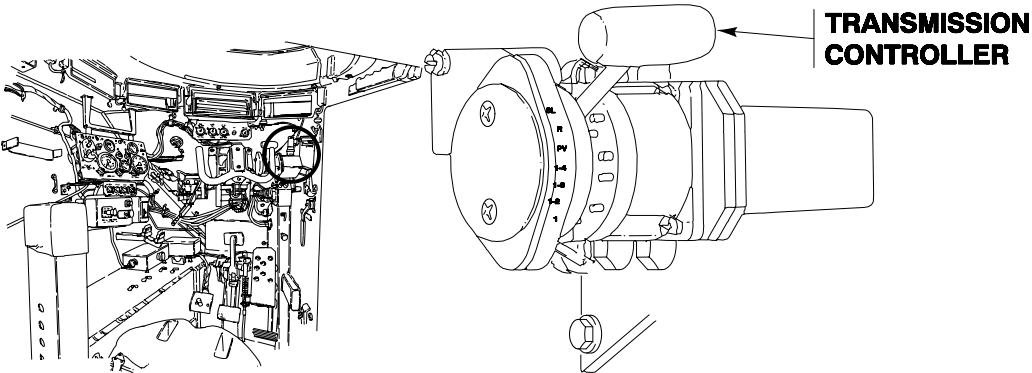
ITEM NO.	INTERVAL	MAN-HOUR	ITEM TO BE CHECKED OR SERVICED	CREWMEMBER PROCEDURE	EQUIPMENT NOT READY/ AVAILABLE IF:
17	Before		Shifting Controls	<p>DRIVER</p> <p>a. Check transmission controller operation.</p>	<p>Transmission controller binds when moved. Transmission does not engage when transmission controller is put in gear.</p>
					

PREVENTIVE MAINTENANCE CHECKS AND SERVICES — Continued

0090 00

ITEM NO.	INTERVAL	MAN-HOUR	ITEM TO BE CHECKED OR SERVICED	CREWMEMBER PROCEDURE	EQUIPMENT NOT READY/ AVAILABLE IF:
18	Before		Steering Controls	<p>DRIVER</p> <p style="text-align: center;">WARNING</p>  <p>Carrier can pivot steer when transmission controller is in SL position and steering lock pin is not engaged. Personnel can be killed or injured. Make sure transmission controller is in SL and steering wheel is centered to engage steering lock pin (steering locked indicator light should be ON) unless carrier is to be steered.</p> <p>a. Check steering wheel operation.</p>	Steering lock pin will not engage. Carrier wanders to right or left when steering wheel is centered. Steering wheel does not return to center when released.

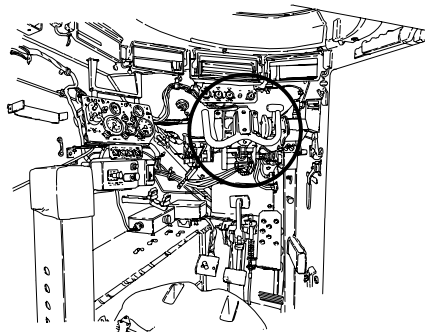

STEERING WHEEL

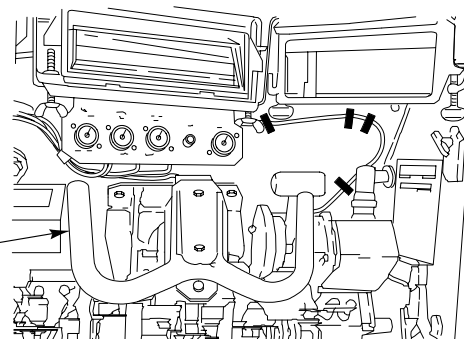

PREVENTIVE MAINTENANCE CHECKS AND SERVICES — Continued

0090 00

ITEM NO.	INTERVAL	MAN-HOUR	ITEM TO BE CHECKED OR SERVICED	CREWMEMBER PROCEDURE	EQUIPMENT NOT READY/ AVAILABLE IF:
19	Before		Braking Controls	<p>DRIVER</p> <p>a. Check carrier brakes.</p> <p style="text-align: center;">NOTE</p> <p>Parking brake handle only supplies enough force to lock service brake pedal. It will not supply enough force to actuate service.</p> <p>b. Check brake pedal while setting parking brake (WP 0020 00). If brake pedal is held firmly or moves downward slightly, parking brake adjustment is ok. If any upward movement of brake pedal is noticed, parking brake must be adjusted. If parking brake will not hold or parking brake handle can be moved very easily, notify unit maintenance.</p>	<p>Brake pedal touches floor when pushed down, or brake does not return freely to off position when released.</p>

PREVENTIVE MAINTENANCE CHECKS AND SERVICES — Continued

0090 00

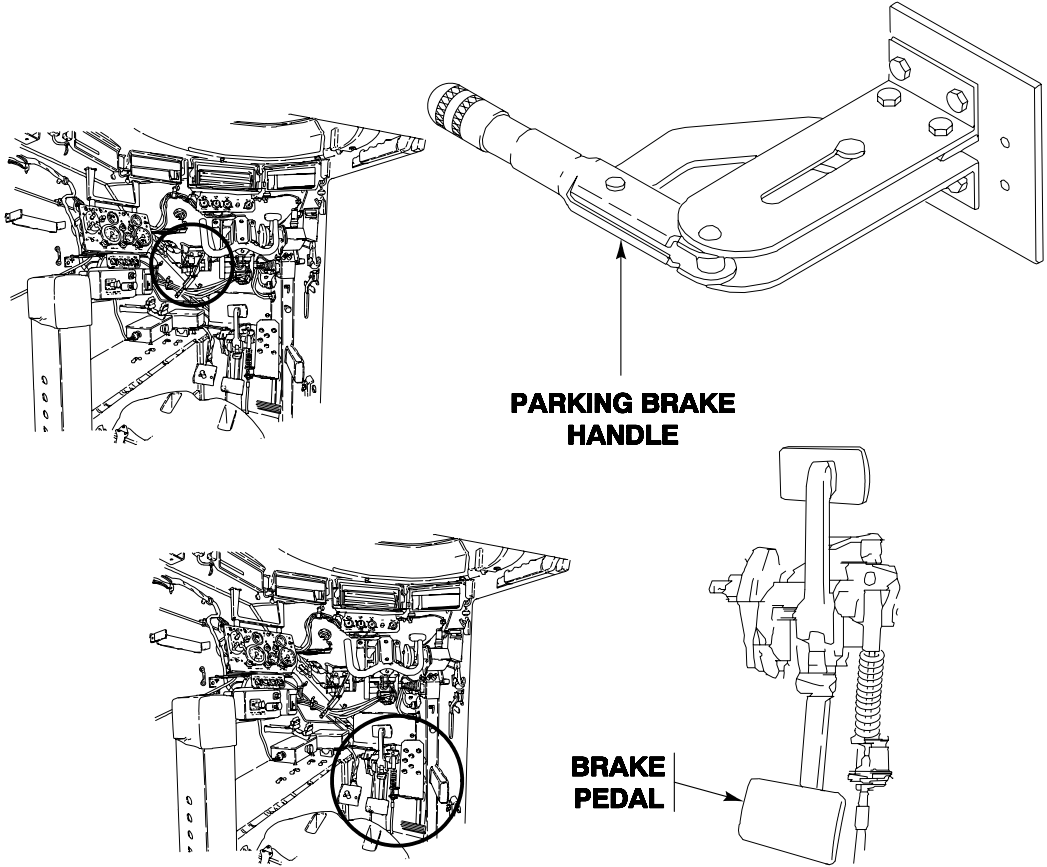
ITEM NO.	INTERVAL	MAN-HOUR	ITEM TO BE CHECKED OR SERVICED	CREWMEMBER PROCEDURE	EQUIPMENT NOT READY/ AVAILABLE IF:
			 <p>The diagram shows two views of a vehicle's interior. The top view shows the parking brake handle, which is a long, curved metal lever with a cylindrical grip, mounted on a metal plate. The bottom view shows the brake pedal, which is a rectangular footplate mounted on a vertical shaft. Both views include callouts with arrows pointing to the respective components.</p>		

ITEM NO.	INTERVAL	MAN-HOUR	ITEM TO BE CHECKED OR SERVICED	CREWMEMBER PROCEDURE	EQUIPMENT NOT READY/ AVAILABLE IF:
20	Before		Carrier Communications Equipment Radio	<p>DRIVER</p> <p>a. Check radio equipment for proper operation. See TM 11-5820-498-12, TM 11-5820-401-10-2, and/or TM 11-5820-890-10-8, as needed. See TM 11-5965-286-14 for headset microphone.</p> <p style="text-align: center;">NOTE</p> <p>M577A3 and M1068A3 carriers may be equipped with the Vehicle Intercommunication System (VIS). See TM 11-5830-263-10 for proper operation.</p> <p>b. Check intercom system for proper operation.</p>	<p>Fault listed in "Equipment Not Ready/ Available If:" column of radio TM. Will not transmit or receive.</p> <p>No intercom between commander and driver.</p>

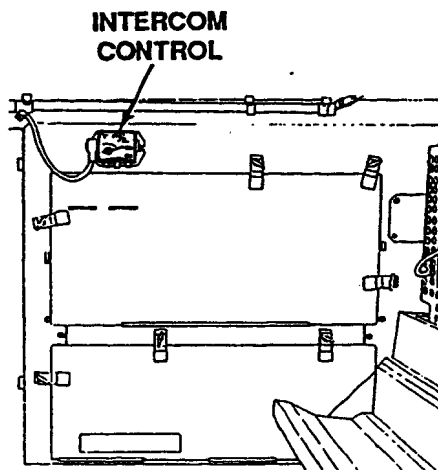
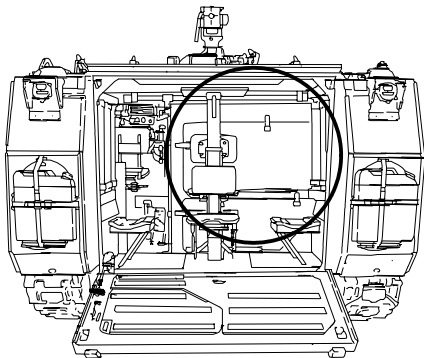

PREVENTIVE MAINTENANCE CHECKS AND SERVICES — Continued

0090 00

ITEM NO.	INTERVAL	MAN-HOUR	ITEM TO BE CHECKED OR SERVICED	CREWMEMBER PROCEDURE	EQUIPMENT NOT READY/ AVAILABLE IF:
21	Before		Mortar Fire Control System (MFCS) (M1064A3 and M577A3)	DRIVER/GUNNER/COMMANDER a. Check MFCS per TM 9-1220-248-10 for M1064A3 or TM 9-1220-249-10 for M577A3.	Fault listed in "Equipment Not Ready/ Available If:" column of MFCS TM.
22	Before		Machine Gun .50 Cal M2 (M113A3, M1059A3, M1064A3, and M58)	COMMANDER <div style="text-align: center;"> <hr style="width: 100px; margin: 0 auto;"/> <p>WARNING</p> <hr style="width: 100px; margin: 0 auto;"/>  </div> <p>Make sure weapon is clear and safe before loading or testing, to prevent accidental firing of machine gun and injury to personnel.</p> a. Check mounting of machine gun in mount. b. Check headspace and timing. See TM 9-1005-213-10 and PMCS.	Machine gun missing or unserviceable. Fault listed in "Equipment Not Ready/ Available If:" column of machine gun TM.

PREVENTIVE MAINTENANCE CHECKS AND SERVICES — Continued

0090 00

ITEM NO.	INTERVAL	MAN-HOUR	ITEM TO BE CHECKED OR SERVICED	CREWMEMBER PROCEDURE	EQUIPMENT NOT READY/ AVAILABLE IF:
23	Before		Mortar Cannon Tube Assembly (M1064A3 Only)	<p>GUNNER</p> <p style="text-align: center;">CAUTION</p> <p>Make sure mortar tube is clean and dry before firing. Damage to equipment may occur.</p> <p>a. See TM 9-1015-250-10 to conduct PMCS for 4.7 inch, 120-mm Mortar.</p>	<p>Fault listed in "Equipment Not Ready/ Available If:" column of mortar gun TM.</p>
24	Before		M157A2 Smoke Generator System (M1059A3 Only)	<p>GENERATOR OPERATOR</p> <p style="text-align: center;">WARNING</p>  <p>All personnel within 75 feet (22.9 meters) of M1059A3 and M58 during operation must wear personnel hearing devices to prevent hearing damage. Contamination is likely, and loss of hearing could occur. Personnel inside carrier in motion, with smoke generator in operation, must wear double hearing protection. Limit exposure of high noise levels to six hours to prevent hearing damage. Use of yellow/white foam ear plugs is prohibited for personnel operating M1059A3 and M58 carrier.</p>	

PREVENTIVE MAINTENANCE CHECKS AND SERVICES — Continued

0090 00

ITEM NO.	INTERVAL	MAN-HOUR	ITEM TO BE CHECKED OR SERVICED	CREWMEMBER PROCEDURE	EQUIPMENT NOT READY/ AVAILABLE IF:
25	Before		Commander's Seat (All except M577A3 or M1068A3)	<p>a. For PMCS procedures, see TM 3-1040-283-10.</p> <p>COMMANDER</p> <p>a. Check for smooth operation of seat and vertical locking mechanism as needed with OE/HDO.</p>	<p>Fault listed in "Equipment Not Ready/ Available If:" column of smoke generator TM.</p> <p>Any missing, broken or cracked seat hardware, less seat cushions or cut, frayed seat belts, or missing seat and post assembly.</p>

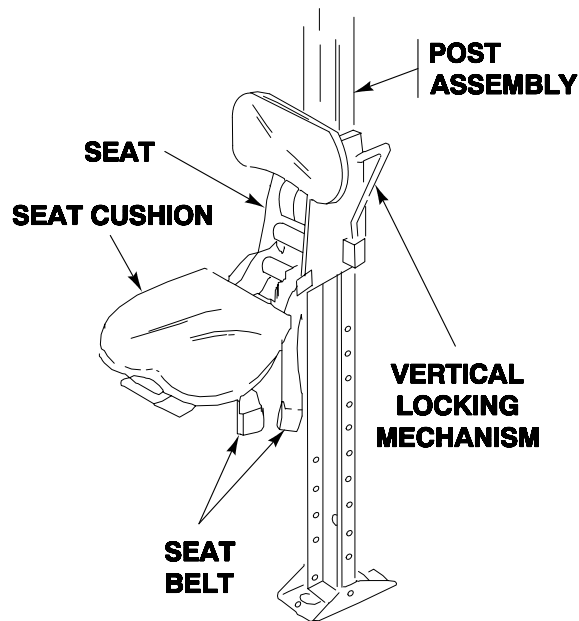

PREVENTIVE MAINTENANCE CHECKS AND SERVICES — Continued

0090 00

ITEM NO.	INTERVAL	MAN-HOUR	ITEM TO BE CHECKED OR SERVICED	CREWMEMBER PROCEDURE	EQUIPMENT NOT READY/ AVAILABLE IF:
26	Before		Driver's Seat, Lap Seatbelt, and Shoulder Harness	<p>DRIVER</p> <p>a. Check for smooth operation of seat, horizontal and vertical locking mechanism. Lubricate as needed with OE/HDO. See WP 0013 00 for seat adjustments.</p> <p>b. Check seat belts for operation and condition of belts, harness ends, belt buckle, belt tongue, and shoulder harness adjuster. See WP 0014 00 for belt and shoulder harness adjuster.</p>	Any missing, broken or cracked seat hardware, less seat cushions or cut, frayed seat belts, or missing seat and post assembly.

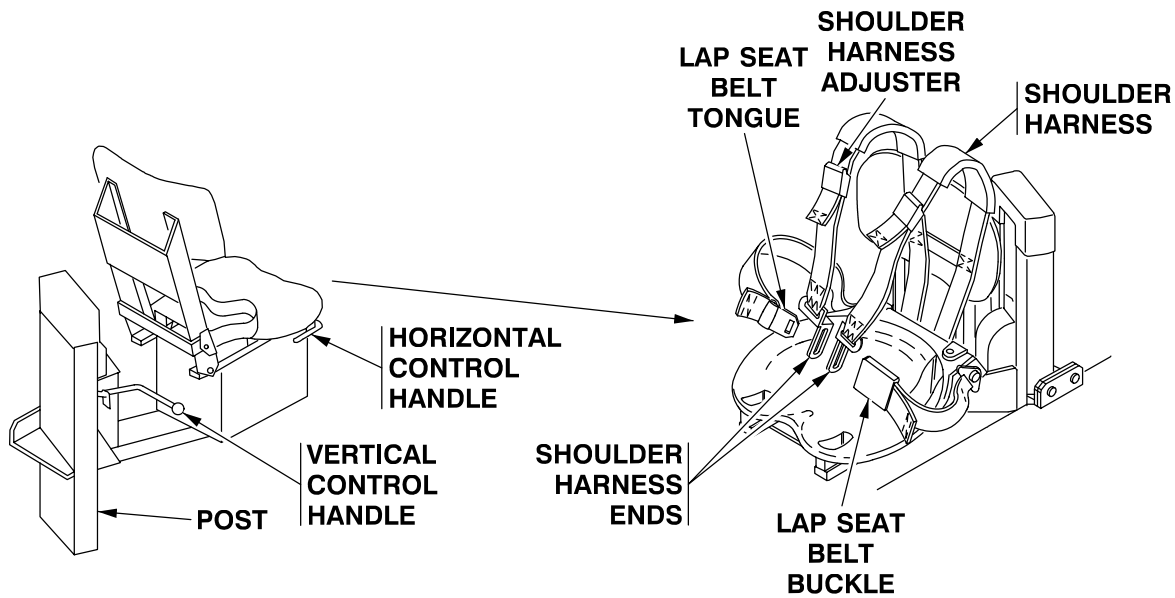

PREVENTIVE MAINTENANCE CHECKS AND SERVICES — Continued

0090 00

ITEM NO.	INTERVAL	MAN-HOUR	ITEM TO BE CHECKED OR SERVICED	CREWMEMBER PROCEDURE	EQUIPMENT NOT READY/ AVAILABLE IF:
27	Before		Smoke Obscurant System (M58 Only)	<p>GENERATOR OPERATOR</p> <p style="text-align: center;">WARNING</p>  <p>All personnel within 75 feet (22.9 meters) of M1059A3 and M58 during operation must wear personnel hearing devices to prevent hearing damage. Contamination is likely, and loss of hearing could occur. Personnel inside carrier in motion, with smoke generator in operation, must wear double hearing protection. Limit exposure of high noise levels to six hours to prevent hearing damage. Use of yellow/white foam ear plugs is prohibited for personnel operating M1059A3 and M58 carrier.</p> <p>a. For PMCS procedures, see TM 3-1040-285-10.</p>	<p>Fault listed in "Equipment Not Ready/ Available If:" column of smoke obscurant system TM.</p>

PREVENTIVE MAINTENANCE CHECKS AND SERVICES — Continued

0090 00

ITEM NO.	INTERVAL	MAN-HOUR	ITEM TO BE CHECKED OR SERVICED	CREWMEMBER PROCEDURE	EQUIPMENT NOT READY/ AVAILABLE IF:
28	Before		Engine Glow Plug Test	<p>DRIVER</p> <p style="text-align: center;">NOTE</p> <p>Perform check whenever ambient temperature is expected to be below 40°F (4°C).</p> <p>a. At engine temperature greater than 50°F (10°C), glow plug WAIT indicator comes on for one second and goes out.</p> <p>b. At engine temperature less than 50°F (10°C), glow plug WAIT indicator comes on for about 35 seconds and then begins to flash for approximately 60 seconds and then goes out.</p>	<p>WAIT indicator does not come on.</p> <p>WAIT indicator flashes during the first 35 seconds of test below engine temperature of 50°F (10°C).</p>

WAIT INDICATOR

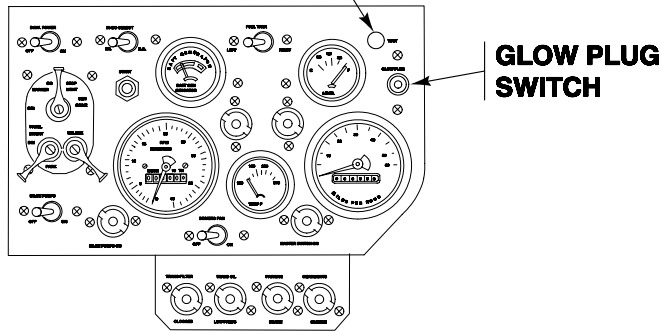

PREVENTIVE MAINTENANCE CHECKS AND SERVICES — Continued

0090 00

ITEM NO.	INTERVAL	MAN-HOUR	ITEM TO BE CHECKED OR SERVICED	CREWMEMBER PROCEDURE	EQUIPMENT NOT READY/ AVAILABLE IF:
29	Before		Driver's Vision Enhancer (DVE) (M58 Only)	DRIVER/COMMANDER a. See TM 11-5855-311-12&P for PMCS procedures for DVE.	Fault listed in "Not Ready/ Available If:" column of DVE TM.

Table 4. Preventive Maintenance Checks and Services for Model M113A3 FOV, During

ITEM NO.	INTERVAL	MAN-HOUR	ITEM TO BE CHECKED OR SERVICED	CREWMEMBER PROCEDURE	EQUIPMENT NOT READY/ AVAILABLE IF:
30	During		Instrument Panel Warning Lights and Gauges	<p>DRIVER</p> <p style="text-align: center;">WARNING</p> <div style="text-align: center;">  </div> <p>If TRANS OIL LOW PRESS warning light stays on, personnel can be injured and equipment can be damaged from erratic vehicle movement. Ensure all ground personnel are clear of the vehicle before engaging transmission. Apply and hold brakes before engaging transmission.</p> <p style="text-align: center;">CAUTION</p> <p>Do not operate vehicle with the TRANS OIL LOW PRESS warning light on. Operating the vehicle with the TRANS OIL LOW PRESS warning light on can damage the transmission and may result in unpredictable vehicle operation.</p>	

ITEM NO.	INTERVAL	MAN-HOUR	ITEM TO BE CHECKED OR SERVICED	CREWMEMBER PROCEDURE	EQUIPMENT NOT READY/ AVAILABLE IF:
				<p style="text-align: center;">CAUTION</p> <p>If the TRANS OIL LOW PRESS comes on or if erratic movement occurs at any time during operation, cease operation immediately. The driver shall shut down the vehicle in accordance with the vehicle operator's manual instructions below:</p> <ul style="list-style-type: none"> • Bring vehicle to a stop. • Place transmission controller in "SL" position. • Set parking brake. • Pull fuel shutoff control. • Turn off master switch. • Secure the vehicle. • Notify unit maintenance for proper disposition. <p style="text-align: center;">NOTE</p> <p>TRANS OIL LOW PRESS warning light may come on when brakes are released, but light should go off when engine speed reaches 1200-1300 RPM.</p> <p>a. During carrier operation, check instrument panel warning lights and gauges periodically for possible carrier malfunctions. Panel indicators should read as follows:</p> <ul style="list-style-type: none"> • Warning lights - all OFF. • Battery Generator indicator - in green zone. <p style="text-align: center;">CAUTION</p> <p>Damage to the engine will occur if the temperature gauge exceeds 230° F (110° C).</p>	<p>Any erratic vehicle movement or TRANS OIL LOW PRESS warning light stays on. Any warning light comes on. Gauge is not in green zone.</p>

PREVENTIVE MAINTENANCE CHECKS AND SERVICES — Continued

0090 00

ITEM NO.	INTERVAL	MAN-HOUR	ITEM TO BE CHECKED OR SERVICED	CREWMEMBER PROCEDURE	EQUIPMENT NOT READY/ AVAILABLE IF:
31	During		Personnel Heater	<p>• Coolant temperature gauge - If outside air temperature is less than 85°F (29°C), normal coolant temperature should be 160-230°F (71-110°C).</p> <p>b. <input type="checkbox"/> Report any abnormal indications to unit maintenance. For a complete description of warning lights and gauges, see WP 0004 00.</p> <p style="text-align: center;">WARNING</p>  <p>Ammunition can explode and kill you. Do not start heater until ammunition and combustible explosive materials are properly stored at least 30 inches from heater vents. Combustible material must be stored 12 inches or more from metal surfaces of heater.</p>	<p>Outside air temperature is less than 85°F (29°C) and gauge is above 200°F (93°C). If outside air temperature is greater than 85°F (29°C) and gauge is above 230°F (110°C), notify unit maintenance immediately.</p>

PREVENTIVE MAINTENANCE CHECKS AND SERVICES — Continued

0090 00

ITEM NO.	INTERVAL	MAN-HOUR	ITEM TO BE CHECKED OR SERVICED	CREWMEMBER PROCEDURE	EQUIPMENT NOT READY/ AVAILABLE IF:
				<p style="text-align: center;">NOTE</p> <p>For Model 5000-30178 (A-20) refer to TM 9-2540-207-14&P for PMCS procedures.</p> <p>a. Check personnel heater fuel lines for leaks, especially near connections. If any fuel leak is found, notify unit maintenance of leaks immediately after operation.</p>	<p>Any fuel leaks in heater or fuel lines.</p>

PREVENTIVE MAINTENANCE CHECKS AND SERVICES — Continued

0090 00

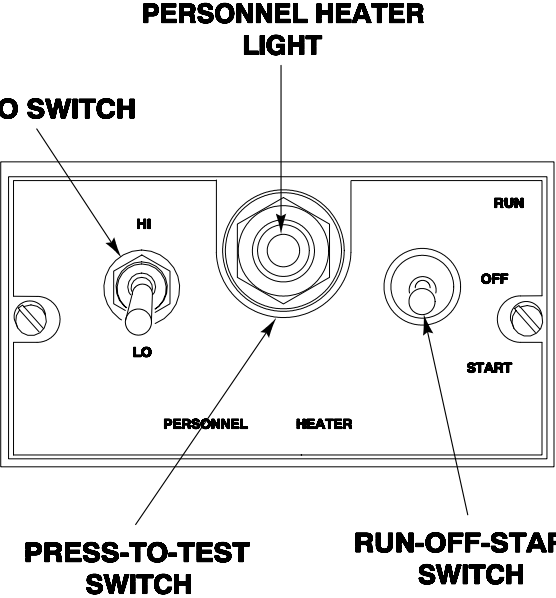
ITEM NO.	INTERVAL	MAN-HOUR	ITEM TO BE CHECKED OR SERVICED	CREWMEMBER PROCEDURE	EQUIPMENT NOT READY/ AVAILABLE IF:
				<p style="text-align: center;">NOTE</p> <p>Make sure nothing is blocking the personnel heater exhaust, air inlet, or heater ducts.</p> <p>b. Check operation of personnel heater electrical circuits.</p> <p>c. Push the PRESS-TO-TEST light cover. Make sure indicator light comes ON before you start heater.</p>	
				<div style="text-align: center;"> <p>PERSONNEL HEATER LIGHT</p>  <p>The diagram shows a control panel with four main components: a HI-LO SWITCH on the left with 'HI' and 'LO' positions; a central PERSONNEL HEATER with a circular indicator light; a PRESS-TO-TEST SWITCH on the right with a 'START' label; and a RUN-OFF-START SWITCH on the far right with 'RUN' and 'OFF' positions. Arrows point from the text labels to their respective components.</p> </div>	

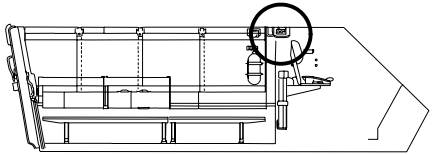

ITEM NO.	INTERVAL	MAN-HOUR	ITEM TO BE CHECKED OR SERVICED	CREWMEMBER PROCEDURE	EQUIPMENT NOT READY/ AVAILABLE IF:
32	During		Coolant Heater	<p>DRIVER</p> <p style="text-align: center;">WARNING</p>  <p>Do not use heater during operation. Injury to personnel may occur.</p> <ol style="list-style-type: none"> Check for leaks in fuel lines and coolant lines. Make sure coolant valves are open before you start heater. Push the PRESS-TO-TEST light cover. Make sure indicator light comes ON before you start heater. Make sure nothing is blocking coolant heater exhaust or air inlet. Check operation of coolant heater electrical circuits. 	Any fuel or coolant leak.

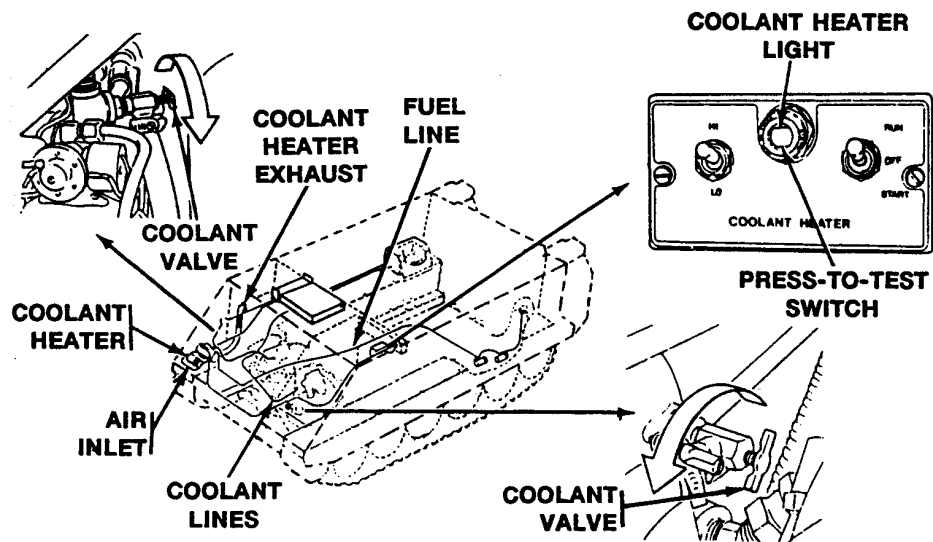

PREVENTIVE MAINTENANCE CHECKS AND SERVICES — Continued

0090 00

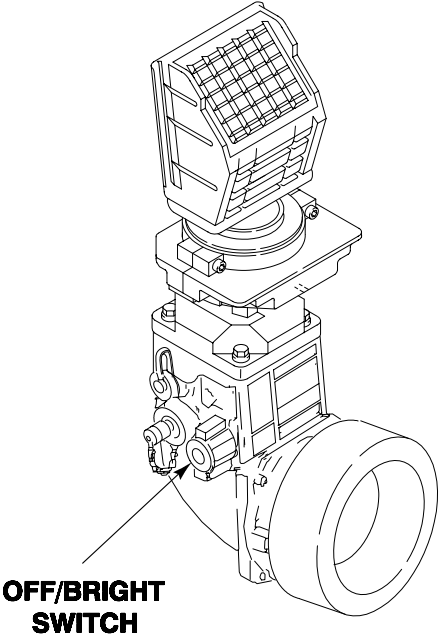
ITEM NO.	INTERVAL	MAN-HOUR	ITEM TO BE CHECKED OR SERVICED	CREWMEMBER PROCEDURE	EQUIPMENT NOT READY/ AVAILABLE IF:
33	During		Driver's Night Viewer Off/Bright Rotary Switch Control	<p>DRIVER</p> <p>a. Rotate OFF/BRIGHT rotary switch control and brightness control. Report deficiencies to unit maintenance.</p>	
 <p>The diagram shows a night viewer assembly consisting of a lensed viewing window at the top, a mounting bracket, and a control panel below. A callout line points to a rotary switch on the control panel labeled 'OFF/BRIGHT SWITCH'.</p>					
34	During		Driver's Vision Enhancer (DVE) (M58 Only)	<p>DRIVER/COMMANDER</p> <p>a. See TM 11-5855-311-12&P for PMCS procedures for DVE.</p>	Fault listed in "Not Ready/ Available If:" column of DVE TM.

PREVENTIVE MAINTENANCE CHECKS AND SERVICES — Continued

0090 00

ITEM NO.	INTERVAL	MAN-HOUR	ITEM TO BE CHECKED OR SERVICED	CREWMEMBER PROCEDURE	EQUIPMENT NOT READY/ AVAILABLE IF:
35	During		Air Cleaner Restriction Indicator	<p>DRIVER</p> <p>a. Check air cleaner restriction indicator. If at any time you see only red in the window and button does not reset when pushed in, stop engine. Clean air cleaner. Recheck.</p>	Air restriction indicator remains red after cleaning filter and resetting. Hose or indicator cracked or damaged.

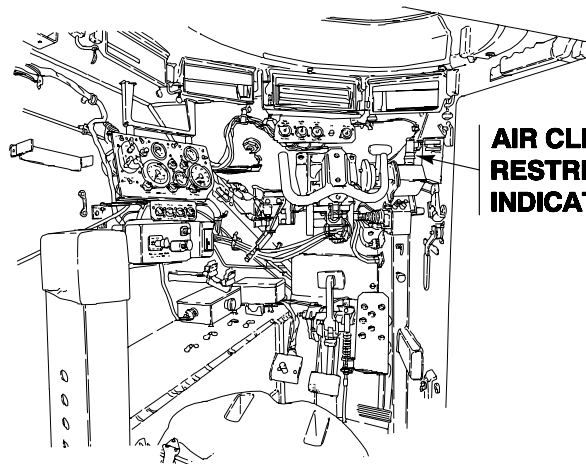

AIR CLEANER RESTRICTION INDICATOR

PREVENTIVE MAINTENANCE CHECKS AND SERVICES — Continued

0090 00

ITEM NO.	INTERVAL	MAN-HOUR	ITEM TO BE CHECKED OR SERVICED	CREWMEMBER PROCEDURE	EQUIPMENT NOT READY/ AVAILABLE IF:
36	During		Steering, Braking, Shifting, and Throttle Controls	<p>DRIVER</p> <p style="text-align: center;">WARNING</p>  <p>Sudden carrier movement can throw you out of seat. Wear seat belts at all times when carrier is in motion, except when performing water operations.</p> <ul style="list-style-type: none"> a. Check steering yoke, range selector, hand throttle, and accelerator. b. Operate steering yoke, range selector (in all ranges), hand throttle, and accelerator pedal. 	<p>If binding, grabbing, unusual noise or vibration is felt during operation of any of these items.</p>

PREVENTIVE MAINTENANCE CHECKS AND SERVICES — Continued

0090 00

ITEM NO.	INTERVAL	MAN-HOUR	ITEM TO BE CHECKED OR SERVICED	CREWMEMBER PROCEDURE	EQUIPMENT NOT READY/ AVAILABLE IF:
37	During		M157A2 Smoke Generator System (M1059A3 Only)	<p>GENERATOR OPERATOR</p> <p style="text-align: center;">WARNING</p>  <p>All personnel within 75 feet (22.9 meters) of M1059A3 and M58 during operation must wear personnel hearing devices to prevent hearing damage. Contamination is likely, and loss of hearing could occur. Personnel inside carrier in motion, with smoke generator in operation, must wear double hearing protection. Limit exposure of high noise levels to six hours to prevent hearing damage. Use of yellow/white foam ear plugs is prohibited for personnel operating M1059A3 and M58 carrier.</p> <p>a. For PMCS procedures, see TM 3-1040-283-10.</p>	<p>Fault listed in "Equipment Not Ready/ Available If:" column of smoke generator TM.</p>

PREVENTIVE MAINTENANCE CHECKS AND SERVICES — Continued

0090 00

ITEM NO.	INTERVAL	MAN-HOUR	ITEM TO BE CHECKED OR SERVICED	CREWMEMBER PROCEDURE	EQUIPMENT NOT READY/ AVAILABLE IF:
38	During		Smoke Obscurant System (M58 Only)	<p style="text-align: center;">WARNING</p>  <p>All personnel within 75 feet (22.9 meters) of M1059A3 and M58 during operation must wear personnel hearing devices to prevent hearing damage. Contamination is likely, and loss of hearing could occur. Personnel inside carrier in motion, with smoke generator in operation, must wear double hearing protection. Limit exposure of high noise levels to six hours to prevent hearing damage. Use of yellow/white foam ear plugs is prohibited for personnel operating M1059A3 and M58 carrier.</p> <p>a. For PMCS procedures, see TM 3-1040-285-10.</p>	Fault listed in "Equipment Not Ready/ Available If:" column of smoke obscurant system TM.
39	During		Mortar Carrier Tube Assembly (M1064A3 Only)	<p>GUNNER</p> <p>a. See TM 9-1015-250-10 to conduct PMCS for 4.7 inch, 120-mm mortar.</p>	Fault listed in "Equipment Not Ready/ Available If:" column of mortar TM.

PREVENTIVE MAINTENANCE CHECKS AND SERVICES — Continued

0090 00

ITEM NO.	INTERVAL	MAN-HOUR	ITEM TO BE CHECKED OR SERVICED	CREWMEMBER PROCEDURE	EQUIPMENT NOT READY/ AVAILABLE IF:
40	During		Mortar Fire Control System (MFCS) (M1064A3 and M577A3)	<p>DRIVER/GUNNER/COMMANDER</p> <p>a. See TM 9-1220-248-10 to conduct PMCS for M1064A3 or TM 9-1220-249-10 to conduct PMCS for M577A3.</p>	<p>Fault listed in "Equipment Not Ready/ Available If:" column of MFCS TM.</p>
41	During		Generator Set (M577A3 and M1068A3)	<p>CREWMEMBER</p> <p>a. See TM 5-6115-596-14 for PMCS procedures.</p>	<p>Fault listed in "Equipment Not Ready/ Available If:" column of generator TM.</p>
42	During		Auxiliary Power Unit (APU) (M577A3 and M1068A3)	<p>CREWMEMBER</p> <p>a. See TM 9-6115-664-13&P for PMCS procedures.</p>	<p>Fault listed in "Equipment Not Ready/ Available If:" column of APU TM.</p>

PREVENTIVE MAINTENANCE CHECKS AND SERVICES — Continued

0090 00

ITEM NO.	INTERVAL	MAN-HOUR	ITEM TO BE CHECKED OR SERVICED	CREWMEMBER PROCEDURE	EQUIPMENT NOT READY/ AVAILABLE IF:
43	During		Seatbelts	<p>COMMANDER</p> <p>a. Ensure all personnel are buckled in their seats. Personnel sitting in open hatch area must not expose more than head and shoulders to name tag level, except when firing weapons.</p>	Missing, worn, torn, or frayed belt. Buckle that will not lock and/or unlock.
44	During		Carrier Communications Equipment	<p>COMMANDER</p> <p>a. Check radio equipment for proper operation. See TM 11-5820-498-12, TM 11-5820-401-10-2, and/or TM 11-5820-890-10-8 as needed.</p> <p style="text-align: center;">NOTE</p> <p>M577A3 and M1068A3 carriers may be equipped with the Vehicle Intercommunication System (VIS). See TM 11-5830-263-10 for proper operation.</p> <p>b. Check intercom controls for proper operation.</p>	<p>Radios do not transmit or receive.</p> <p>No intercom between commander and driver.</p>

ITEM NO.	INTERVAL	MAN-HOUR	ITEM TO BE CHECKED OR SERVICED	CREWMEMBER PROCEDURE	EQUIPMENT NOT READY/ AVAILABLE IF:
<p style="text-align: center;">M58 SHOWN</p>					

Table 5. Preventive Maintenance Checks and Services for Model M113A3 FOV, After

ITEM NO.	INTERVAL	MAN-HOUR	ITEM TO BE CHECKED OR SERVICED	CREWMEMBER PROCEDURE	EQUIPMENT NOT READY/ AVAILABLE IF:
45	After		Engine Shutdown	<p>DRIVER</p> <p style="text-align: center;">WARNING</p>  <p style="text-align: center;">Hot parts can burn you. Let hot parts cool before you start work.</p> <p>a. <input type="checkbox"/> Stop engine (WP 0024 00).</p>	Engine won't shut down.
46	After		Driver's Power Plant Compartment	<p>DRIVER</p> <p>a. Remove operator's power plant access panel and check for signs of leaks in fuel lines, coolant hoses, oil lines, and air intake ducts. Report Class I and II fluid leaks after operation.</p>	Any Class III oil or coolant leak or any fuel leak. Any holes or tears in flexible ducts.

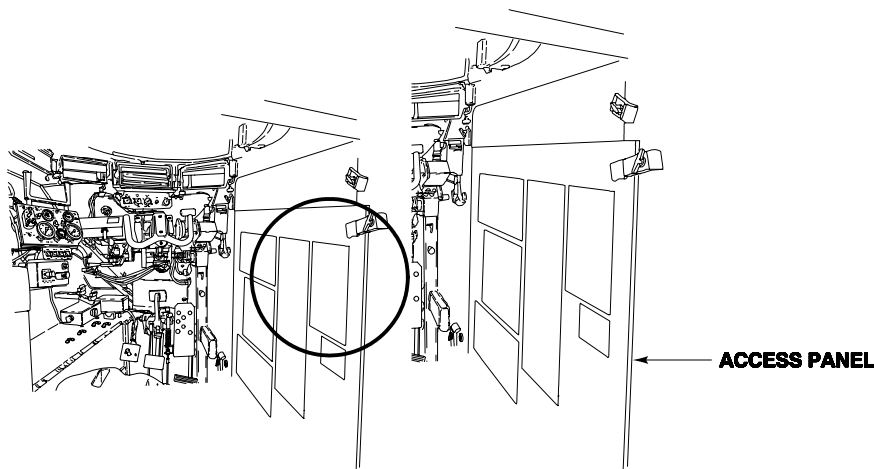

ITEM NO.	INTERVAL	MAN-HOUR	ITEM TO BE CHECKED OR SERVICED	CREWMEMBER PROCEDURE	EQUIPMENT NOT READY/ AVAILABLE IF:
47	After	0.3	Engine Oil Level	<p>DRIVER</p> <p style="text-align: center;">CAUTION</p> <p>Engine can be damaged if filled above F (Full) mark.</p> <p>Do not add oil unless below L (Low) mark.</p> <p>Do not mix OE/HDO-15W40 with single grade lubricants.</p> <p style="text-align: center;">NOTE</p> <p>Carrier must be on level surface when checking oil level.</p> <p style="text-align: center;">NOTE</p> <p>Visual inspection of engine oil should not be justification to replace oil. Diesel engine oil may appear black due to additives.</p> <p>Notify unit maintenance to change oil and oil filters when converting from OE/HDO to OEA, PE-30-1 to OE/HDO, etc.</p> <p>For AOAP sampling requirements and procedures, see page 0090 00-4.</p>	

PREVENTIVE MAINTENANCE CHECKS AND SERVICES — Continued

0090 00

ITEM NO.	INTERVAL	MAN-HOUR	ITEM TO BE CHECKED OR SERVICED	CREWMEMBER PROCEDURE	EQUIPMENT NOT READY/ AVAILABLE IF:
48	After	0.3	Fuel Filter	<p>a. Check engine oil level. Oil level on engine dipstick should be between L (Low) and F (Full) marks. Add oil as needed. Do not overfill. Oil level should not be above F (Full) mark. See Lubrication Tables (Table 2, page 0090 00-7).</p> <div data-bbox="167 646 1356 1081" data-label="Image"> </div>	<p>Any sign of Class III leak. Any fuel leak.</p>
				<p>DRIVER</p> <div data-bbox="873 1304 1068 1373" data-label="Section-Header"> <p>WARNING</p> </div> <div data-bbox="886 1400 1052 1566" data-label="Image"> </div> <p>Fuel is flammable. Always use in area with good air flow, away from heat or flames. Do not breathe fumes. If fuel gets on hands, wash them. If fuel gets in eyes, flush with water and get medical help. Keep fire extinguisher nearby.</p>	

PREVENTIVE MAINTENANCE CHECKS AND SERVICES — Continued

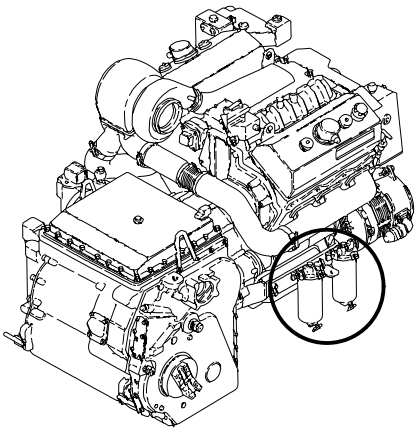
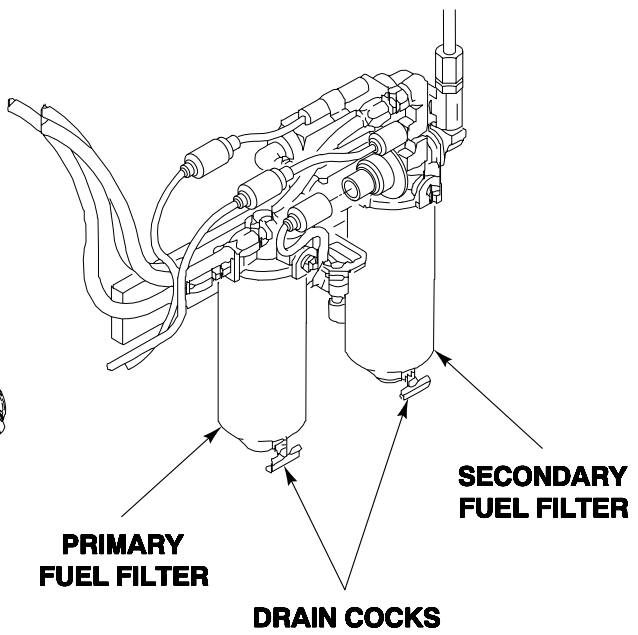
ITEM NO.	INTERVAL	MAN-HOUR	ITEM TO BE CHECKED OR SERVICED	CREWMEMBER PROCEDURE	EQUIPMENT NOT READY/AVAILABLE IF:
				<p>a. Drain water and sediment from engine primary and secondary fuel filters as follows:</p> <ol style="list-style-type: none"> 1) Place suitable container under primary fuel filter. Open drain cock to drain water and sediment from primary fuel filter. When clean fuel starts to drain out, close drain cock. 2) Repeat step above for secondary fuel filter. If sediment or water is found when draining secondary fuel filter, notify unit maintenance. <p>b. Check for fuel leaks at primary and secondary fuel filters. If leak is found, notify unit maintenance.</p>	<p>Any fuel leak.</p> <p>Any fuel leak.</p>
				 <p>PRIMARY FUEL FILTER</p> <p>SECONDARY FUEL FILTER</p> <p>DRAIN COCKS</p>	

ITEM NO.	INTERVAL	MAN-HOUR	ITEM TO BE CHECKED OR SERVICED	CREWMEMBER PROCEDURE	EQUIPMENT NOT READY/ AVAILABLE IF:
49	After		Driver's Power Plant Access Panel	<p style="text-align: center;">CAUTION</p> <p>Unsealed or missing panels may cause coolant system to overheat because air does not flow through the radiator but instead will flow through unsealed or missing panels. Damage to the power train components due to overheating may occur.</p> <ol style="list-style-type: none"> a. Check driver's power plant access panel to make sure it seals tightly. b. Check panel for damage or warps. c. Check panel latches for looseness. Tighten loose latches. Report missing latches to unit maintenance. d. Check rubber seals for breaks, brittleness, cracks, or poor seating. 	Latch missing or will not tighten.

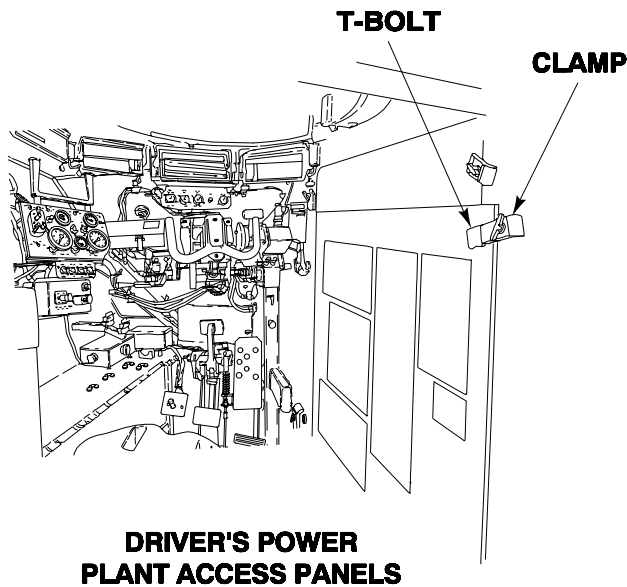

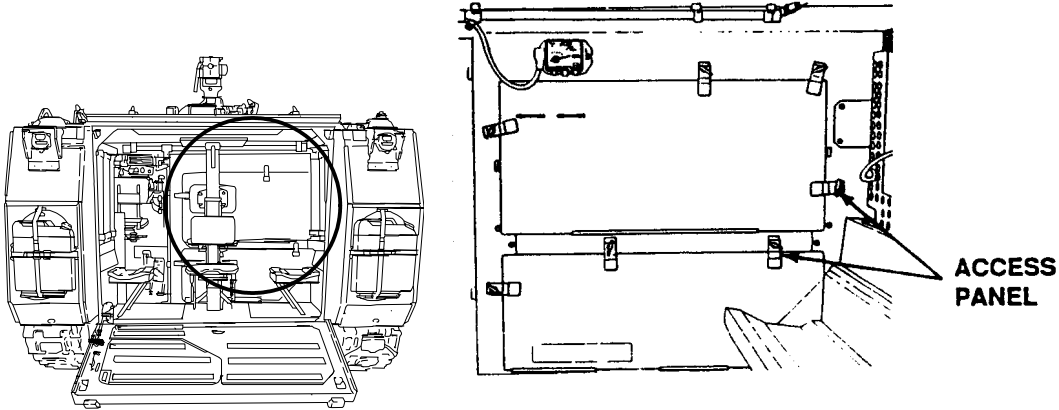

PREVENTIVE MAINTENANCE CHECKS AND SERVICES — Continued

0090 00

ITEM NO.	INTERVAL	MAN-HOUR	ITEM TO BE CHECKED OR SERVICED	CREWMEMBER PROCEDURE	EQUIPMENT NOT READY/ AVAILABLE IF:
50	After		Rear Power Plant Compartment	<p>DRIVER</p> <p>a. Remove rear power plant access panel and check for signs of leaks in fuel lines, coolant hoses, oil lines, and air intake ducts. Report Class I and II fluid leaks after operation.</p>	Any Class III oil or coolant leaks, holes, or tears in flexible ducts. Any fuel leak.
					

PREVENTIVE MAINTENANCE CHECKS AND SERVICES — Continued

0090 00

ITEM NO.	INTERVAL	MAN-HOUR	ITEM TO BE CHECKED OR SERVICED	CREWMEMBER PROCEDURE	EQUIPMENT NOT READY/ AVAILABLE IF:
51	After	0.2	Carrier Ramp	<p>DRIVER</p> <p style="text-align: center;">WARNING</p>  <p>Lowering ramp could injure personnel. Make sure no one is in ramp zone before you lower ramp. If tactical situation permits, sound horn before lowering ramp.</p> <p>a. Lower ramp.</p> <p style="text-align: center;">WARNING</p>  <p>Fire resistant hydraulic (FRH) fluid may contain Tricresyl Phosphate which, if taken internally, can produce paralysis. Hydraulic fluid may be absorbed through the skin. Wear long sleeves, gloves, goggles, and face shield. If FRH gets in eyes, wash them immediately and get medical aid immediately. If FRH gets on your skin, thoroughly wash with soap and water. Wash hands thoroughly prior to eating or smoking. Application of these measures is considered an effective control of the hazard.</p>	Ramp will not lower or raise.

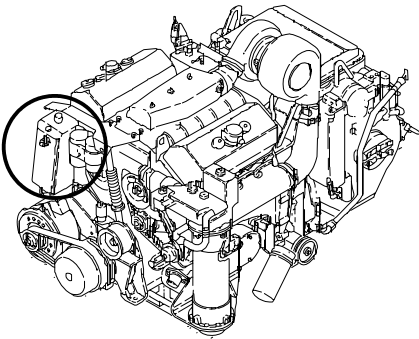
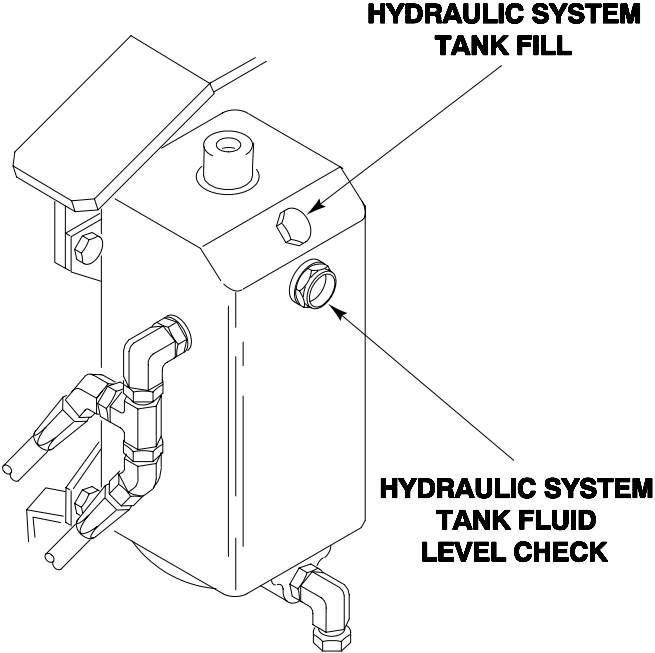
ITEM NO.	INTERVAL	MAN-HOUR	ITEM TO BE CHECKED OR SERVICED	CREWMEMBER PROCEDURE	EQUIPMENT NOT READY/ AVAILABLE IF:
				<p style="text-align: center;">CAUTION</p> <p>Use only FRH hydraulic fluid. Do not mix different types of fluid. Do NOT overfill.</p> <p>b. Check ramp hydraulic fluid level with ramp down and carrier on level ground. Fluid level must be visible halfway up in ramp hydraulic fluid level sight glass. To add FRH, remove fill plug and preformed packing from top of tank. Add FRH as needed. See Lubrication Tables (Table 2, page 0090 00-8). Install fill plug and new preformed packing.</p>	<p>Fluid is not visible half way up in sight glass. Breather cap is missing.</p>
					

PREVENTIVE MAINTENANCE CHECKS AND SERVICES — Continued

0090 00

ITEM NO.	INTERVAL	MAN-HOUR	ITEM TO BE CHECKED OR SERVICED	CREWMEMBER PROCEDURE	EQUIPMENT NOT READY/ AVAILABLE IF:
52	After		Drive Belts	<p>DRIVER</p> <p>a. Check generator, coolant pump, and coolant fan drive belts for looseness, wear, and damage.</p>	Any drive belt missing, broken, cracks to the belt fiber, has more than one crack (1/8 inch in depth or 50% of belt thickness) or has frays more than 2 inches long.

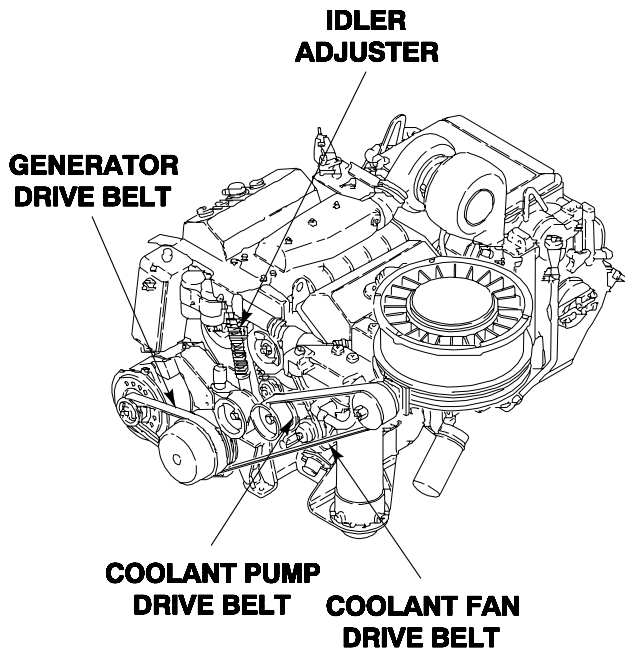

PREVENTIVE MAINTENANCE CHECKS AND SERVICES — Continued

0090 00

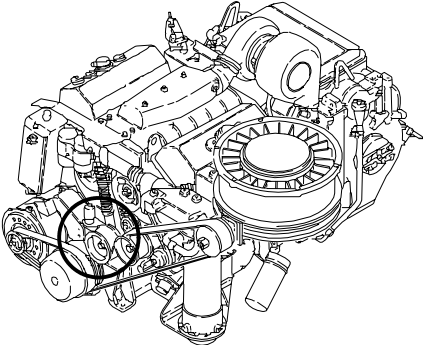
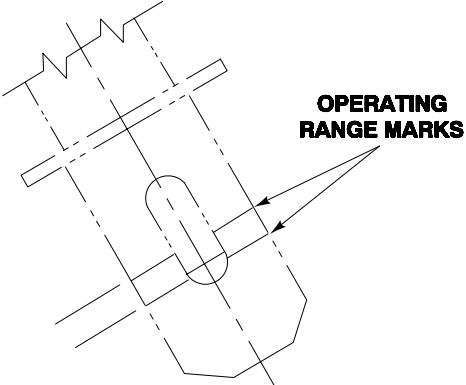
ITEM NO.	INTERVAL	MAN-HOUR	ITEM TO BE CHECKED OR SERVICED	CREWMEMBER PROCEDURE	EQUIPMENT NOT READY/ AVAILABLE IF:
				<p>b. Check idler adjuster for proper adjustment (between operating range marks). If idler is not in operating range and coolant fan drive belt has more than 1/2 inch deflection between pulleys, notify unit maintenance.</p> 	<p>Fan assembly grinding or squeaking. Loose or missing idler adjuster and/or hardware.</p>

PREVENTIVE MAINTENANCE CHECKS AND SERVICES — Continued

0090 00

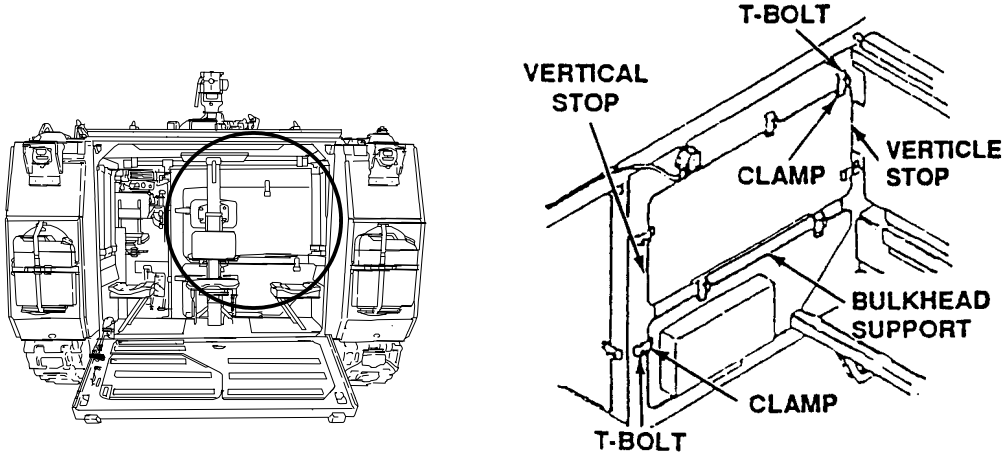
ITEM NO.	INTERVAL	MAN-HOUR	ITEM TO BE CHECKED OR SERVICED	CREWMEMBER PROCEDURE	EQUIPMENT NOT READY/ AVAILABLE IF:
53	After		Rear Power Plant Access Panel	<p>DRIVER</p> <p style="text-align: center;">CAUTION</p> <p>Make sure rear power plant access panel is closed tightly before continuing your PMCS or operating carrier.</p> <ol style="list-style-type: none"> a. Check rear compartment access panel for good sealing. b. Check panel for damage or warps. c. Check panel latches for looseness. Tighten loose latches. Report missing latches to unit maintenance. d. Check rubber seals for breaks, brittleness, cracks, or poor seating. 	Latch is missing or will not tighten.
					

PREVENTIVE MAINTENANCE CHECKS AND SERVICES — Continued

0090 00

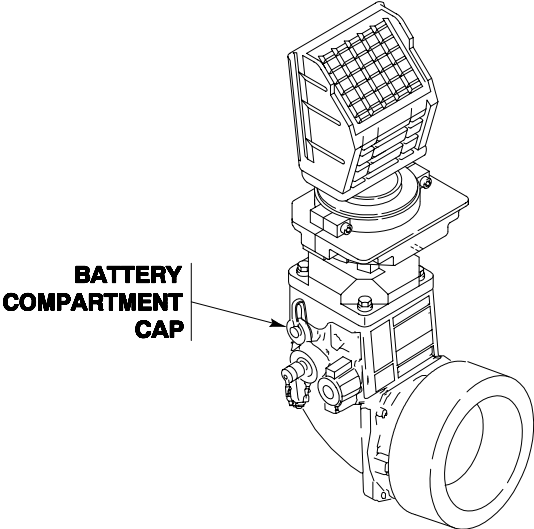
ITEM NO.	INTERVAL	MAN-HOUR	ITEM TO BE CHECKED OR SERVICED	CREWMEMBER PROCEDURE	EQUIPMENT NOT READY/ AVAILABLE IF:
54	After		Driver's Night Viewer Battery	<p>DRIVER</p> <p>a. Remove battery compartment cap and remove battery after operation. Replace battery compartment cap.</p>	
					
55	After		Driver's Vision Enhancer (DVE) (M58 Only)	<p>DRIVER/COMMANDER</p> <p>a. See TM 11-5855-311-12&P for PMCS procedures for DVE.</p>	Fault listed in "Not Ready/ Available If:" column of DVE TM.
56	After		Driver's Night Viewer	<p>DRIVER</p> <p>a. Inspect the exterior surface. They should be clean, free of dust, dirt, grease, and fungus.</p>	

PREVENTIVE MAINTENANCE CHECKS AND SERVICES — Continued

0090 00

ITEM NO.	INTERVAL	MAN-HOUR	ITEM TO BE CHECKED OR SERVICED	CREWMEMBER PROCEDURE	EQUIPMENT NOT READY/ AVAILABLE IF:
57	After	1.0	50 Cal. Machine Gun or 40mm MK19 Machine Gun (All Except M577A3 and M1068A3)	<p>COMMANDER</p> <p>a. Perform PMCS per Machine Gun manual (TM 9-1005-213-10 or TM 9-1010-230-10).</p>	<p>Fault listed in "Equipment Not Ready/ Available If:" column of machine gun TM.</p>
58	After		Machine Gun Mount 50 Cal. M2 (All Except M577A3 and M1068A3)	<p>COMMANDER</p> <p>a. Check gun mount for missing pins. Check for tightness of all fasteners and operating parts. Operate ammo box locking latch. When locked, ammo box must be sturdy and secure.</p>	<p>Damaged, binding, or missing parts or pin.</p>

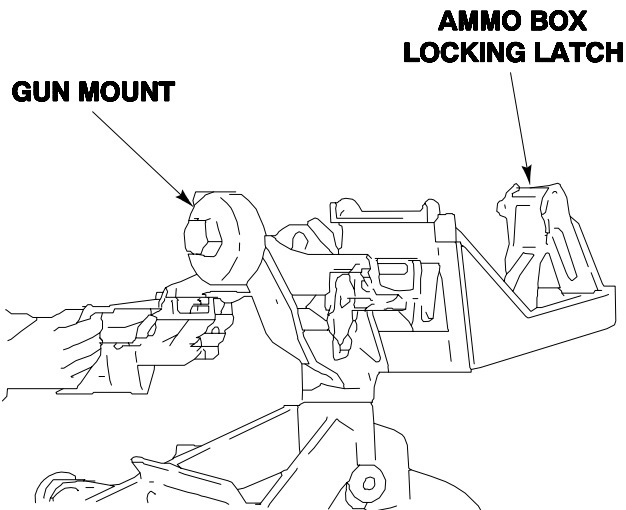
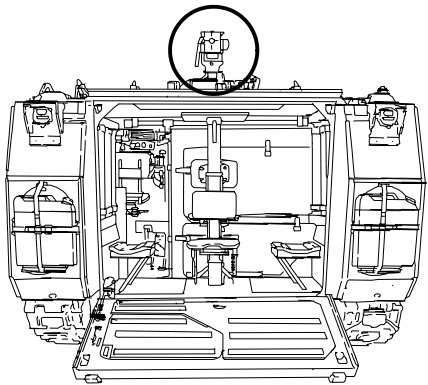

PREVENTIVE MAINTENANCE CHECKS AND SERVICES — Continued

0090 00

ITEM NO.	INTERVAL	MAN-HOUR	ITEM TO BE CHECKED OR SERVICED	CREWMEMBER PROCEDURE	EQUIPMENT NOT READY/ AVAILABLE IF:
59	After		Commander's Cupola (M113A3, M1059A3, M1064A3, and M58)	<p>COMMANDER</p> <ol style="list-style-type: none"> a. Check that cupola lock locks movement of the cupola. Release lock and test cupola for ease of movement (WP 0010 00). b. Check operation of drag brake (WP 0010 00). Report damaged lock or drag brake to unit maintenance. 	

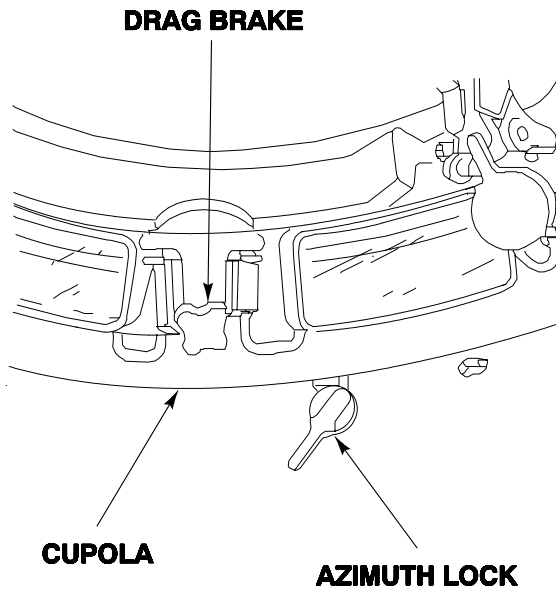
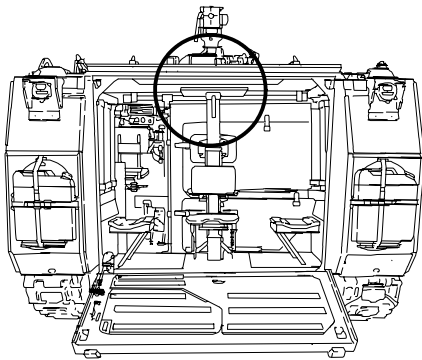

ITEM NO.	INTERVAL	MAN-HOUR	ITEM TO BE CHECKED OR SERVICED	CREWMEMBER PROCEDURE	EQUIPMENT NOT READY/ AVAILABLE IF:
60	After		Smoke Grenade Launcher (M113A3, M1059A3, and M58)	<p>COMMANDER</p> <ol style="list-style-type: none"> a. Indicator light comes on when ARM/OFF switch is set to on. b. Check electrical connector to launcher control for bent pins, frayed wires, tears, or any damage rendering the cable unserviceable. 	

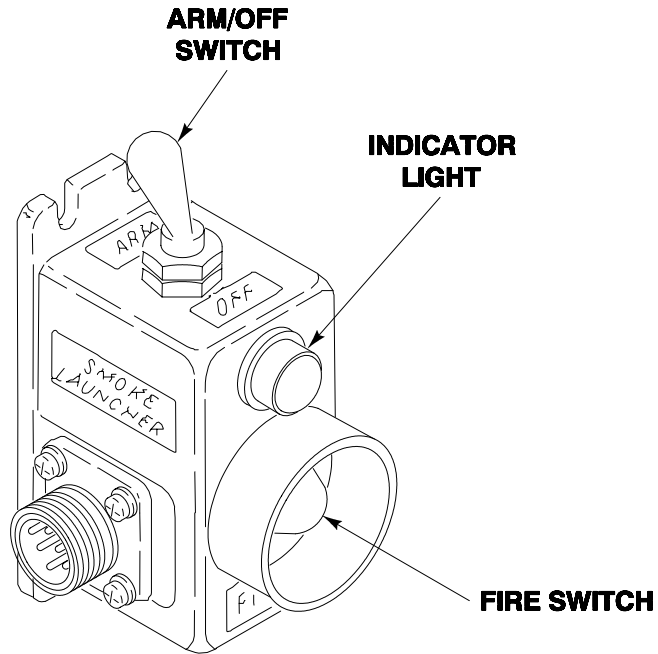
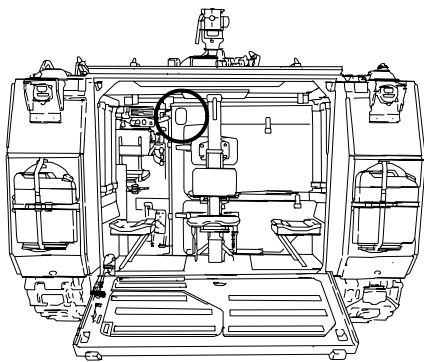



CAUTION

Do not use wire brush to clean launcher tubes. Brush may cause damage to tubes.

- c. Clean smoke grenade launcher tubes.
 - 1) During continued firing, clean tubes with cleaning compound (WP 0104 00, Item 5). Do not wipe dry or lubricate.

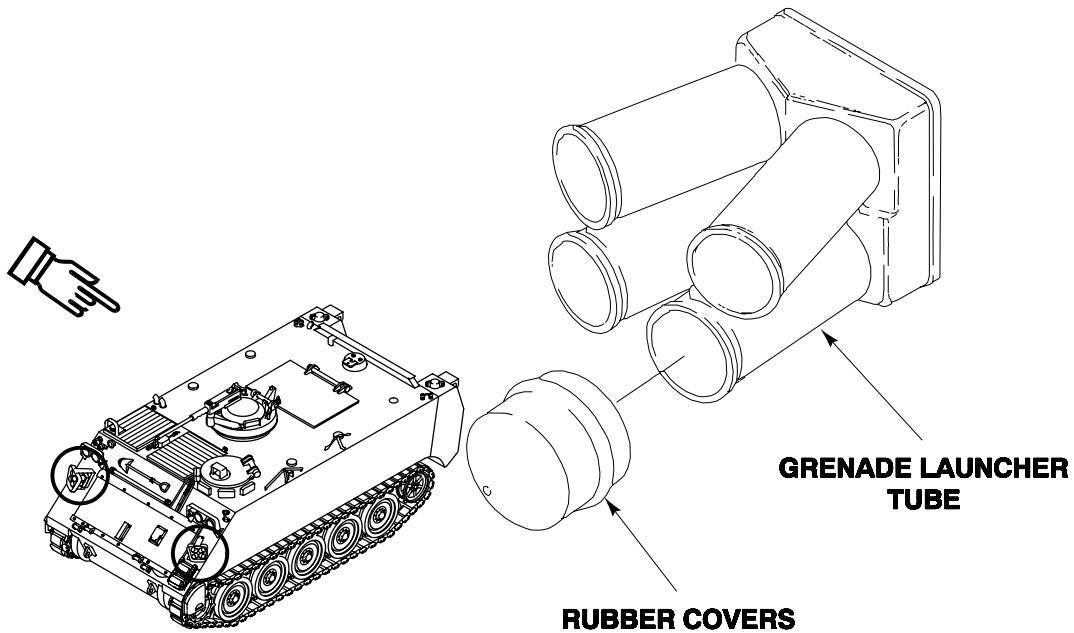
ITEM NO.	INTERVAL	MAN-HOUR	ITEM TO BE CHECKED OR SERVICED	CREWMEMBER PROCEDURE	EQUIPMENT NOT READY/ AVAILABLE IF:
				<ol style="list-style-type: none"> 2) Clean debris from barrel drain holes by inserting stiff wire, if necessary. 3) Be sure that no residue remains around tip plugs located at bottom center in each barrel. 4) Immediately after firing and for two consecutive days thereafter, thoroughly clean tubes with cleaning compound (WP 0104 00, Item 5). Make sure all surfaces are well coated. Do not wipe dry. 5) Three days after last firing, clean tubes with cleaning compound (WP 0104 00, Item 5). Wipe dry with clean cloth (WP 0104 00, Item 7). <p>d. Covering Launchers.</p> <ol style="list-style-type: none"> 1) After each cleaning, install rubber covers on launcher tubes. 	

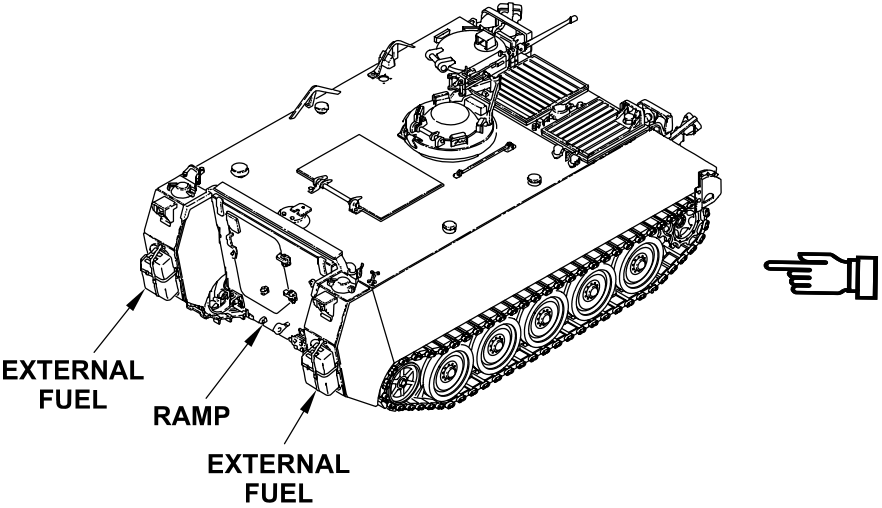

ITEM NO.	INTERVAL	MAN-HOUR	ITEM TO BE CHECKED OR SERVICED	CREWMEMBER PROCEDURE	EQUIPMENT NOT READY/ AVAILABLE IF:
61	After		Fuel Lines (All Except M577A3 and M1068A3)	<p>DRIVER</p> <p style="text-align: center;">WARNING</p> <div style="text-align: center;">  </div> <p>Fuel lines may vibrate loose or crack during mortar firing. Fuel leaks can cause fumes or fires which cause serious bodily harm or death to personnel. If fuel leaks, STOP FIRING. Repair leaks or cracks and wipe up any excess fuel before you resume firing.</p> <p>a. Check carrier fuel lines for leaks. Report any leaks to unit maintenance.</p>	Any fuel leak.
					

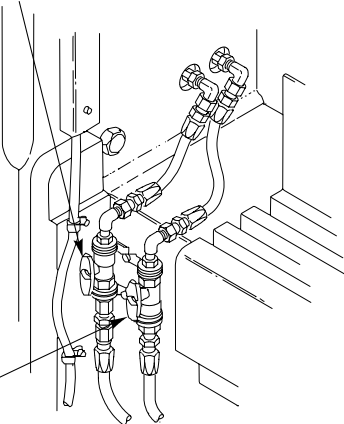
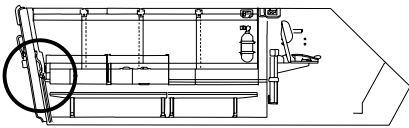
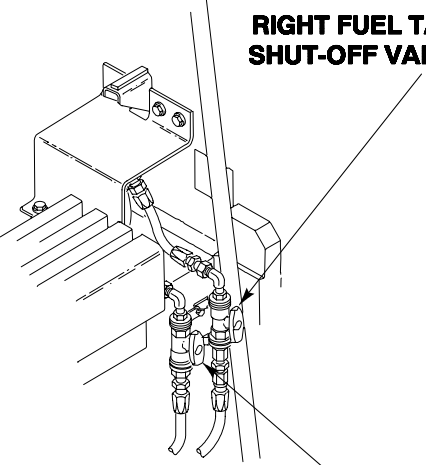
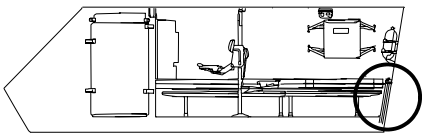
ITEM NO.	INTERVAL	MAN-HOUR	ITEM TO BE CHECKED OR SERVICED	CREWMEMBER PROCEDURE	EQUIPMENT NOT READY/ AVAILABLE IF:
			<p style="text-align: center;">LEFT FUEL TANK MANUAL SHUT-OFF VALVE (SUPPLY)</p>  <p style="text-align: center;">LEFT FUEL TANK MANUAL SHUT-OFF VALVE (RETURN)</p>  <p style="text-align: center;">RIGHT FUEL TANK MANUAL SHUT-OFF VALVE (RETURN)</p>  <p style="text-align: center;">RIGHT FUEL TANK MANUAL SHUT-OFF VALVE (SUPPLY)</p> 		

PREVENTIVE MAINTENANCE CHECKS AND SERVICES — Continued

0090 00

ITEM NO.	INTERVAL	MAN-HOUR	ITEM TO BE CHECKED OR SERVICED	CREWMEMBER PROCEDURE	EQUIPMENT NOT READY/AVAILABLE IF:
			Fuel Lines (Cont.) (M577A3 and M1068A3)	a. Check carrier fuel lines for leaks. Report any leaks to unit maintenance.	Any fuel leak.

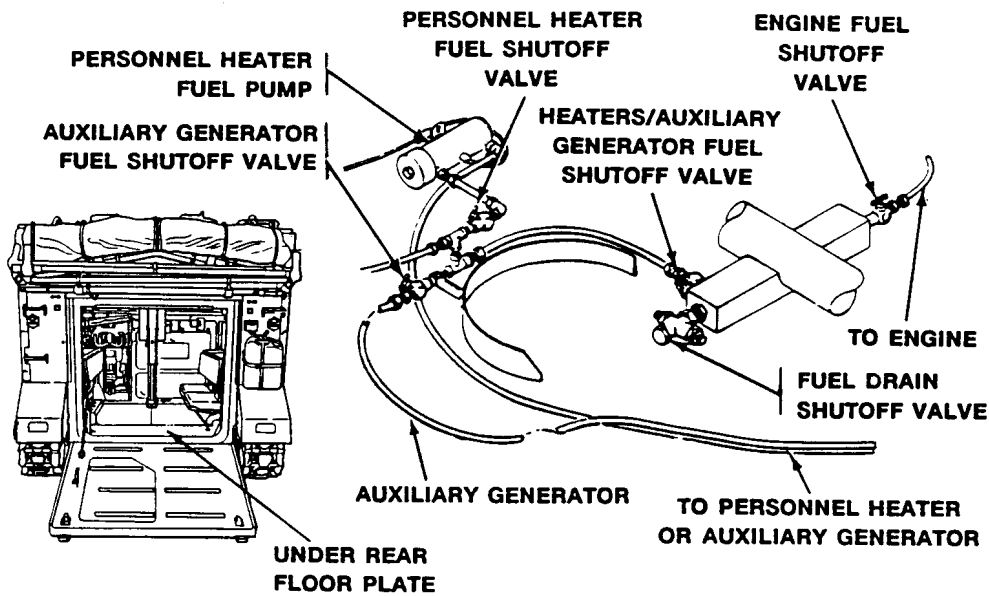

62	After		Fuel Tank and Filler Cap	<p>DRIVER</p> <p style="text-align: center;">WARNING</p> <div style="text-align: center;">  </div> <p>Make sure carrier is properly grounded before refueling. Fuel can catch fire and burn you. Wipe up spilled fuel.</p>	
----	-------	--	--------------------------	---	--

ITEM NO.	INTERVAL	MAN-HOUR	ITEM TO BE CHECKED OR SERVICED	CREWMEMBER PROCEDURE	EQUIPMENT NOT READY/ AVAILABLE IF:
				<p>a. Make sure filler screen is clean and in good shape. If the screen needs cleaning, do it before you fill up on fuel. Install screen before refueling. Make sure filler cap is OK and seals tightly on filler neck.</p> <p style="text-align: center;">NOTE</p> <p>M577A3 and M1068A3 have only one fuel filler cap located on right rear hull.</p>	
63	After		Front Access Power Plant Compartment	DRIVER	

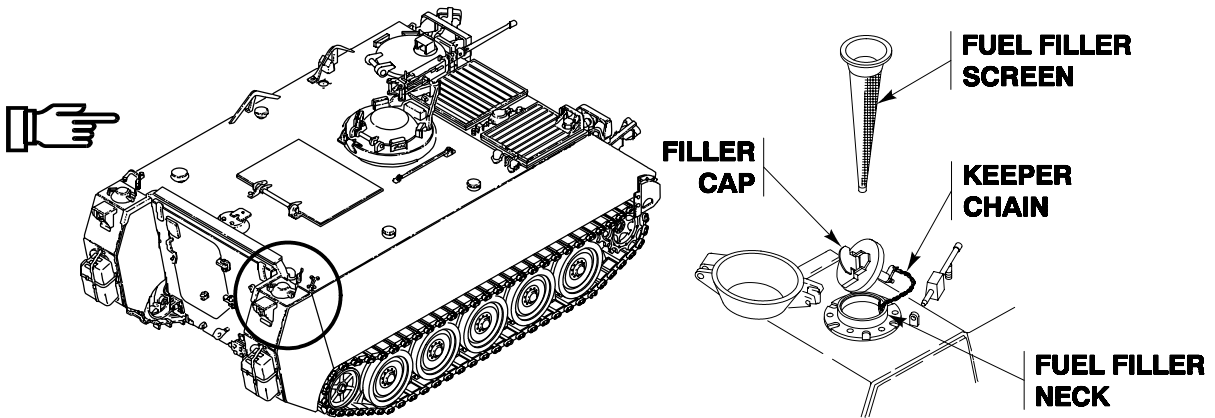

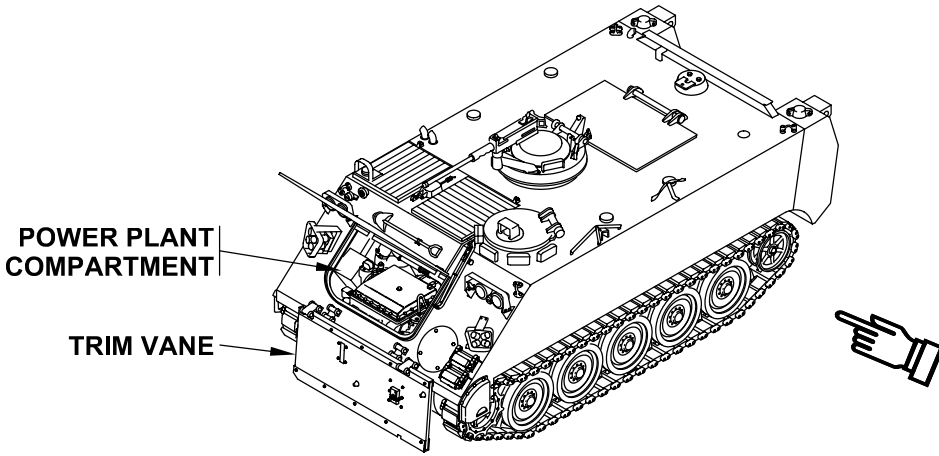
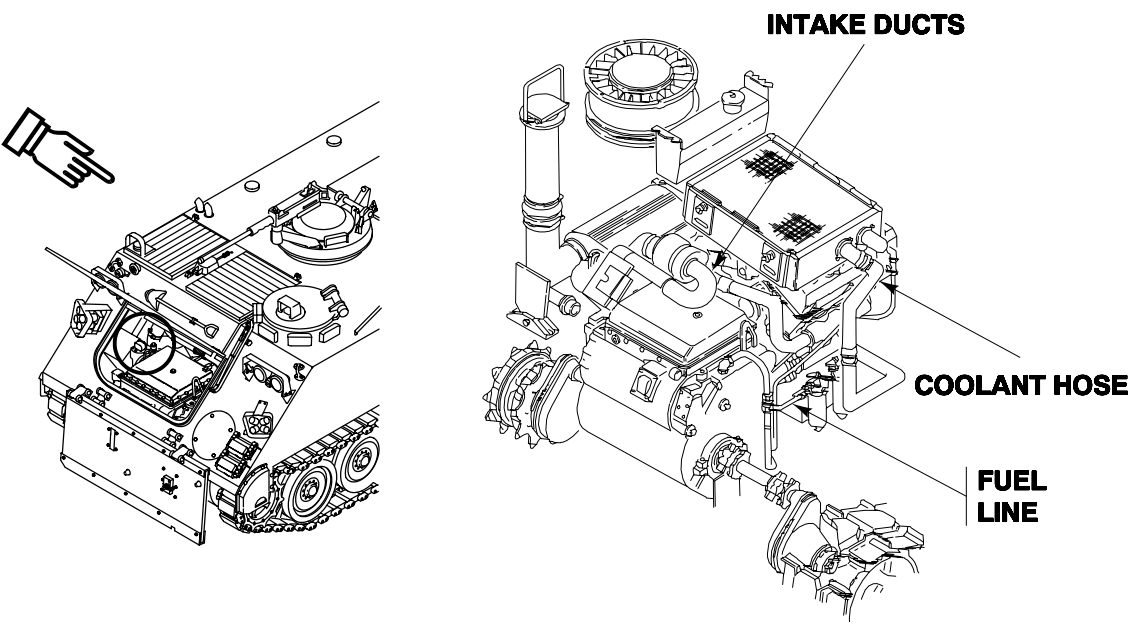
ITEM NO.	INTERVAL	MAN-HOUR	ITEM TO BE CHECKED OR SERVICED	CREWMEMBER PROCEDURE	EQUIPMENT NOT READY/ AVAILABLE IF:
				a. Check inside power plant compartment for leaks and damage.	Any Class III oil or coolant leaks. Any fuel leaks.
					
				b. Check air intake ducts and fuel lines for signs of damage and loose fittings.	Any holes or tears in flexible air intake.
					

PREVENTIVE MAINTENANCE CHECKS AND SERVICES — Continued

0090 00

ITEM NO.	INTERVAL	MAN-HOUR	ITEM TO BE CHECKED OR SERVICED	CREWMEMBER PROCEDURE	EQUIPMENT NOT READY/ AVAILABLE IF:
64	After	0.2	Transmission Oil Level	<p>DRIVER</p> <p style="text-align: center;">CAUTION</p> <p>Transmission can be damaged if filled above FULL mark on gauge rod. Do NOT mix OE/HDO-15W40 with single grade lubricants.</p> <p style="text-align: center;">NOTE</p> <p>Carrier must be on level surface when checking oil level. For early model transmissions, the dipstick is also the fill tube. On late model transmissions, the fill tube is on the brake cover and the dipstick is separate.</p> <p style="text-align: center;">NOTE</p> <p>Visual inspection of transmission oil should not be justification to replace oil. Detergent transmission oils may appear dark in color due to additives.</p> <p>Notify unit maintenance to change oil and oil filters when converting from OE/HDO to OEA, PE-10-1 to OE/HDO, etc.</p> <p>For AOAP sampling requirements and procedures, see page 0090 00-4.</p>	

PREVENTIVE MAINTENANCE CHECKS AND SERVICES — Continued

0090 00

ITEM NO.	INTERVAL	MAN-HOUR	ITEM TO BE CHECKED OR SERVICED	CREWMEMBER PROCEDURE	EQUIPMENT NOT READY/ AVAILABLE IF:
				a. Check transmission oil level. Before operation, oil level should be at FULL mark on gauge rod. Just after carrier operation when oil is warm, oil level should be at or just above ADD mark on gauge rod. Add oil as needed. Do not overfill. See Lubrication Tables (Table 2, page 0090 00-8).	Any sign of Class III leak. Any fuel leak.

DIPSTICK (EARLY MODEL)

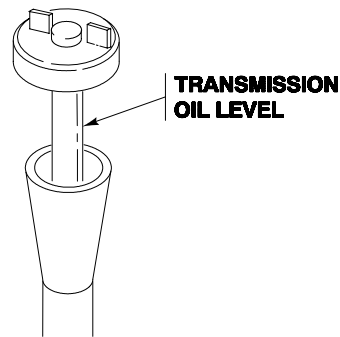
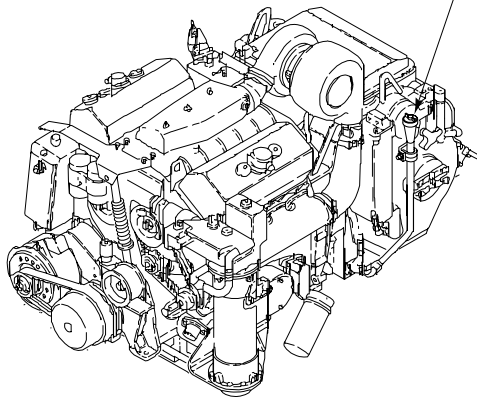

DIPSTICK (LATE MODEL)

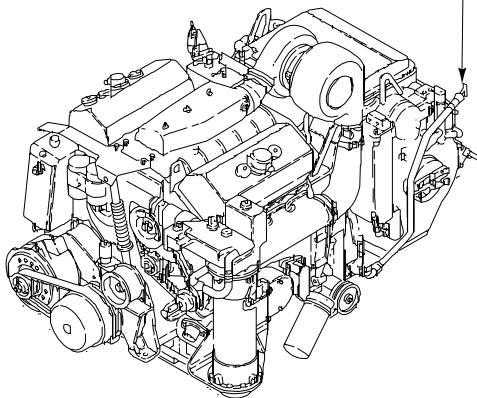

PREVENTIVE MAINTENANCE CHECKS AND SERVICES — Continued

0090 00

ITEM NO.	INTERVAL	MAN-HOUR	ITEM TO BE CHECKED OR SERVICED	CREWMEMBER PROCEDURE	EQUIPMENT NOT READY/ AVAILABLE IF:
65	After		Final Drives Housings	<p>DRIVER</p> <p style="text-align: center;">WARNING</p>  <p>Final drive housings can heat up enough to burn you.</p> <ol style="list-style-type: none"> a. Check final drive housings for overheating. Feel each final drive housing. If it is too hot to touch, report overheated final drive housing to unit maintenance. b. Check drain plugs. 	<p>Any overheated drive housing.</p> <p>Drain plug missing.</p>

PREVENTIVE MAINTENANCE CHECKS AND SERVICES — Continued

0090 00

ITEM NO.	INTERVAL	MAN-HOUR	ITEM TO BE CHECKED OR SERVICED	CREWMEMBER PROCEDURE	EQUIPMENT NOT READY/ AVAILABLE IF:
66	After		Propeller Shafts, Universal Joints	<p>DRIVER</p> <p>a. Check propeller shafts, universal joints, mating coupling, and yokes for loose or missing mounting hardware, corrosion, and evidence of wear/damage.</p>	Any damaged, loose, or missing mounting hardware or parts.
<p>The diagram shows an exploded view of a propeller shaft assembly. It includes a propeller shaft with a coupling at one end and a yoke at the other. A universal joint is shown between the shaft and the yoke. The labels 'COUPLING', 'PROPELLER SHAFT', 'UNIVERSAL JOINT', and 'YOKE' are positioned around the assembly with arrows pointing to their respective parts.</p>					

PREVENTIVE MAINTENANCE CHECKS AND SERVICES — Continued

0090 00

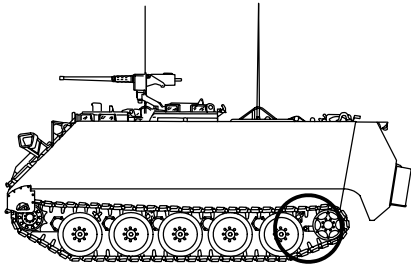
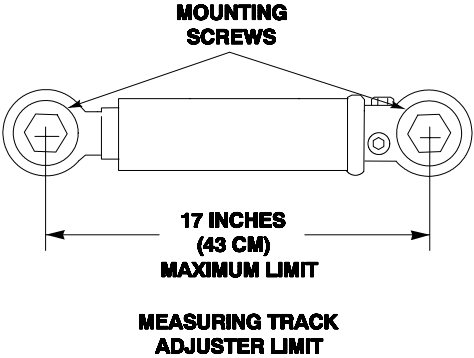
ITEM NO.	INTERVAL	MAN-HOUR	ITEM TO BE CHECKED OR SERVICED	CREWMEMBER PROCEDURE	EQUIPMENT NOT READY/ AVAILABLE IF:
67	After		Track Tension	<p>DRIVER</p> <p>a. Check for missing or damaged track adjusters.</p> <p style="text-align: center;">CAUTION</p> <p>Track adjuster extended too far may buckle and become damaged during operation. Do not extend track adjuster beyond 17 inches (43 cm) (maximum), as measured between centers of track adjuster and mounting screws. Adjust track after vehicle has been unloaded of equipment.</p> <p>b. Adjust track tension as necessary (T130) (WP 0091 00) or (T150) (WP 0091 01).</p>	Track adjuster missing or unserviceable.
<div style="display: flex; justify-content: space-around; align-items: center;"> <div style="text-align: center;">  </div> <div style="text-align: center;">  </div> <div style="text-align: center;">  <p>MOUNTING SCREWS</p> <p>17 INCHES (43 CM) MAXIMUM LIMIT</p> <p>MEASURING TRACK ADJUSTER LIMIT</p> </div> </div>					

PREVENTIVE MAINTENANCE CHECKS AND SERVICES — Continued

0090 00

ITEM NO.	INTERVAL	MAN-HOUR	ITEM TO BE CHECKED OR SERVICED	CREWMEMBER PROCEDURE	EQUIPMENT NOT READY/ AVAILABLE IF:
68	After		Sprockets and Cushions	<p>DRIVER</p> <p>a. Check sprockets for cracked, broken, or missing teeth and loose or missing mounting bolts. Report cracked, broken, or missing sprocket teeth and missing mounting bolts to unit maintenance. Tighten loose mounting bolts as needed. Mark bolts and notify unit maintenance to torque.</p>	<p>Any sprocket tooth is cracked, broken, or missing. Any sprocket to carrier mounting bolt missing. Two or more carrier to hub mounting bolts missing.</p>
<p>The diagrams illustrate the components to be inspected. On the left, a T130 track sprocket is shown with a mounting bolt. In the middle, a T150 track sprocket is shown with a mounting bolt. On the right, a top-down view of a tank's track system is shown, with a hand pointing to the sprocket area.</p>					
<p>NOTE</p> <p>New style drive sprockets (T150) have a round circle for a wear indicator and do not require profile gauge to measure sprocket tooth wear. The old drive sprockets (T130) will still require the use of the profile gauge to measure the sprocket teeth.</p>					

ITEM NO.	INTERVAL	MAN-HOUR	ITEM TO BE CHECKED OR SERVICED	CREWMEMBER PROCEDURE	EQUIPMENT NOT READY/ AVAILABLE IF:
				<p>b. Check sprocket teeth for wear. Use profile gauge on old style drive sprockets (T130) to measure sprocket teeth. If any of the sprocket teeth does not extend beyond gauge or wear indicator (on newer sprockets), notify unit maintenance. New style (T150) sprocket teeth have a wear gauge as a part of the sprocket. If only one side of sprocket shows wear, notify unit maintenance to reverse sprocket.</p> <p>c. Check cushions for wear and damage. If cushions appear to be moving on sprocket hub, notify unit maintenance. If track shoes are contacting sprocket hub flange, a thumping sound will be heard. Cushions should be replaced. Notify unit maintenance.</p>	<p>Any sprocket tooth fails gauge test or is worn to the wear indicator.</p>

PREVENTIVE MAINTENANCE CHECKS AND SERVICES — Continued

0090 00

ITEM NO.	INTERVAL	MAN-HOUR	ITEM TO BE CHECKED OR SERVICED	CREWMEMBER PROCEDURE	EQUIPMENT NOT READY/ AVAILABLE IF:
69	After		Roadwheels and Idler Wheels	<p>DRIVER</p> <p style="text-align: center;">WARNING</p>  <p>Roadwheel hubs and idler wheel hubs can heat up enough to burn you.</p> <p>a. Check roadwheels for separation of rubber from metal.</p> <p>b. Check for missing, bent, warped, or cracked roadwheels or idler wheels.</p>	<p>Separation of one-half of rubber contact from the wheel. Chunking across one-half width of outer rubber surface.</p> <p>Missing, bent, warped, or cracked roadwheel or idler wheel. Mounting holes elongated.</p>

PREVENTIVE MAINTENANCE CHECKS AND SERVICES — Continued

0090 00

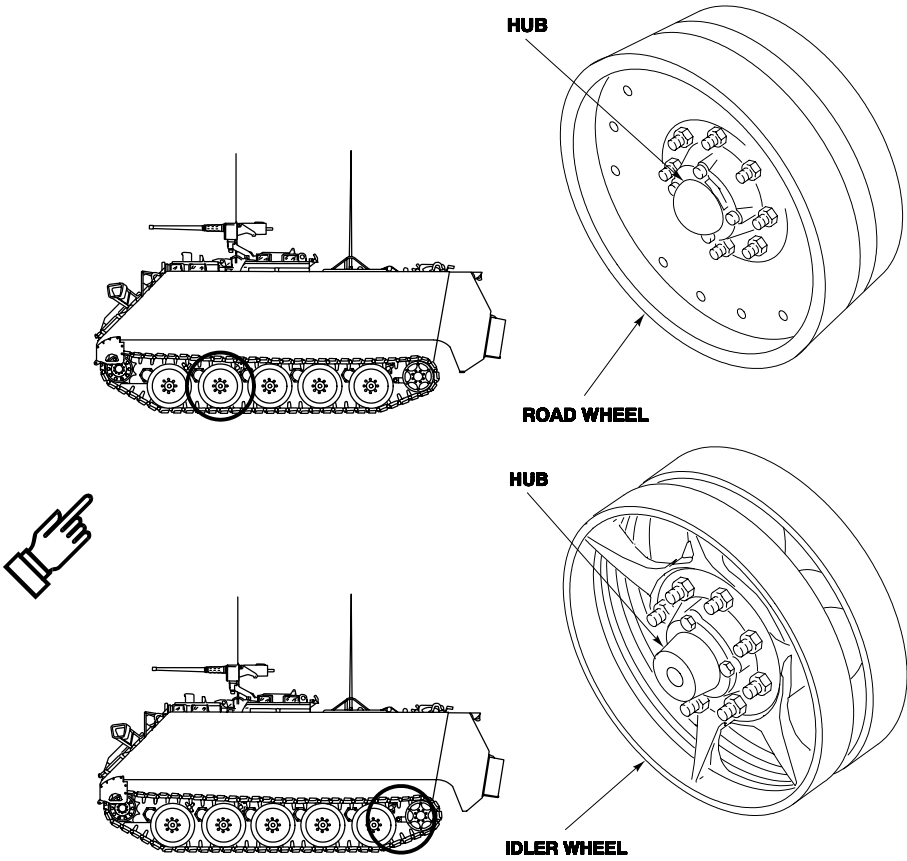
ITEM NO.	INTERVAL	MAN-HOUR	ITEM TO BE CHECKED OR SERVICED	CREWMEMBER PROCEDURE	EQUIPMENT NOT READY/ AVAILABLE IF:
					

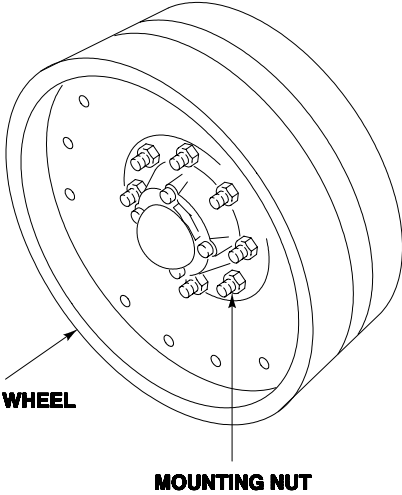
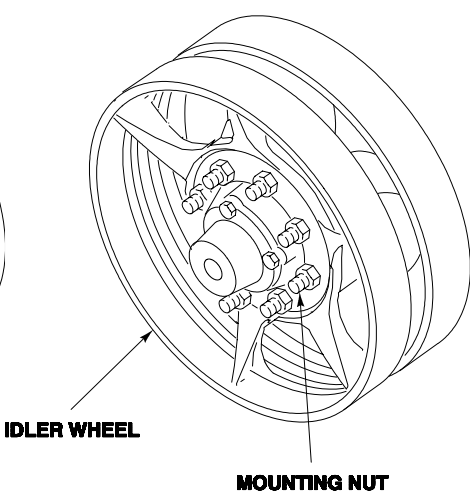
ITEM NO.	INTERVAL	MAN-HOUR	ITEM TO BE CHECKED OR SERVICED	CREWMEMBER PROCEDURE	EQUIPMENT NOT READY/ AVAILABLE IF:
				<p style="text-align: center;">NOTE</p> <p>If a hub feels hotter than any other or is hotter than normal, you may have a bearing that needs service.</p> <p>c. Feel roadwheel hubs and idler wheel hubs. Report any hub that feels hotter than others to unit maintenance.</p> <p>d. Check roadwheels and idler wheels for worn mounting holes by looking for a shiny area around mounting holes.</p>	<p>Any stud or nut loose or missing or holes elongated.</p>
					
				<p>e. Check roadwheel and idler wheel hubs for lubricant leakage from around outer hub cap and between rear of hub and support arm.</p>	<p>Any damaged hub or Class III leak.</p>

ITEM NO.	INTERVAL	MAN-HOUR	ITEM TO BE CHECKED OR SERVICED	CREWMEMBER PROCEDURE	EQUIPMENT NOT READY/ AVAILABLE IF:
70	After		Shock Absorbers	<p>DRIVER</p> <p style="text-align: center;">WARNING</p> <div style="text-align: center;">  </div> <p>Shock absorbers can heat up enough to burn you.</p> <p style="text-align: center;">NOTE</p> <p>Small dents in shock absorber should not affect its performance. Feel all shock absorbers after use. A cold shock is defective and should be replaced.</p> <ul style="list-style-type: none"> a. Check for leaks. If shock is cold or has a Class III leak, report it to unit maintenance. b. Check shock absorbers. After a good run on rough terrain or bumpy course, shock absorbers should be warm enough so you can tell they have been operating properly. 	<p>Any shock absorber is broken or cold after operation. Any Class III leak. Any shock absorber missing.</p>

ITEM NO.	INTERVAL	MAN-HOUR	ITEM TO BE CHECKED OR SERVICED	CREWMEMBER PROCEDURE	EQUIPMENT NOT READY/ AVAILABLE IF:
71	After		Torsion Bars and Roadwheel Arms	<p>DRIVER</p> <p>a. Check for bent, broken, or missing roadwheel arms and torsion bars. With crowbar, try to lift each roadwheel. If any roadwheel comes up easily, you have a broken or missing torsion bar. Report any broken or missing torsion bar to unit maintenance.</p>	Any bolt loose or missing.

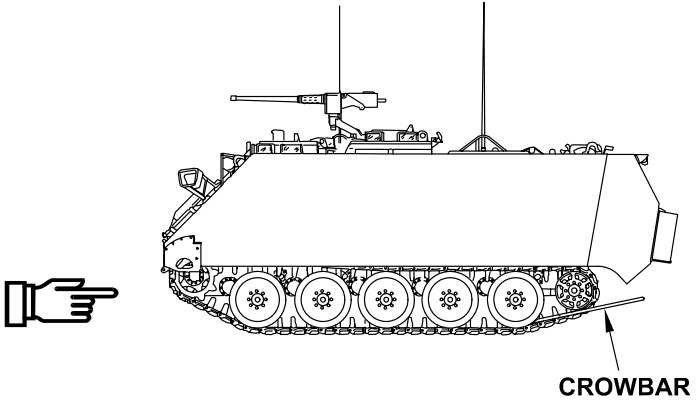
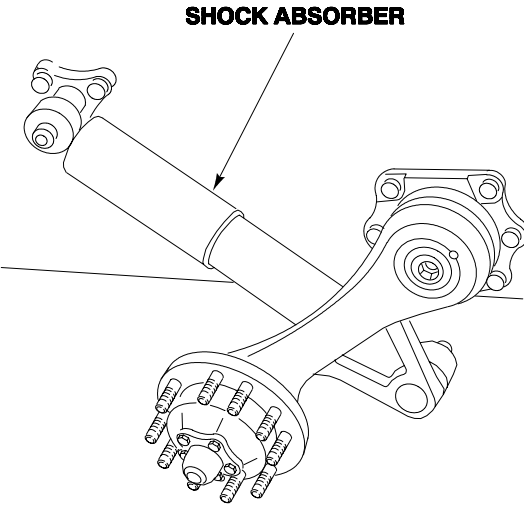
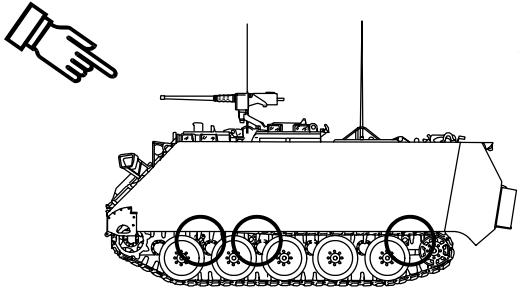

ITEM NO.	INTERVAL	MAN-HOUR	ITEM TO BE CHECKED OR SERVICED	CREWMEMBER PROCEDURE	EQUIPMENT NOT READY/ AVAILABLE IF:
72	After		Seat Belts	<p>COMMANDER</p> <p>a. Check that all seat belts operate properly and are serviceable.</p>	
73	After		Hatches (M1064A3 Only)	<p>CREWMEMBER</p> <p>a. Check mortar carrier latches.</p> <p>b. Check operation of exterior catches on all hatches. Check interior latches.</p> <p>c. Check hatch seals for breaks, brittleness, cracks, and poor sealing. Report any damaged hatch, seal, catches, missing or inoperable locking pins to unit maintenance.</p>	<p>Latches on any hatch that do not hold the hatch in open or closed position. Any hatch locking pins missing or inoperable.</p>

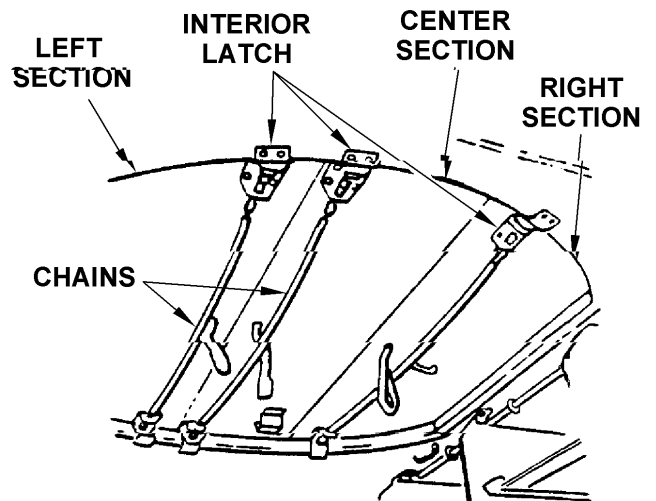
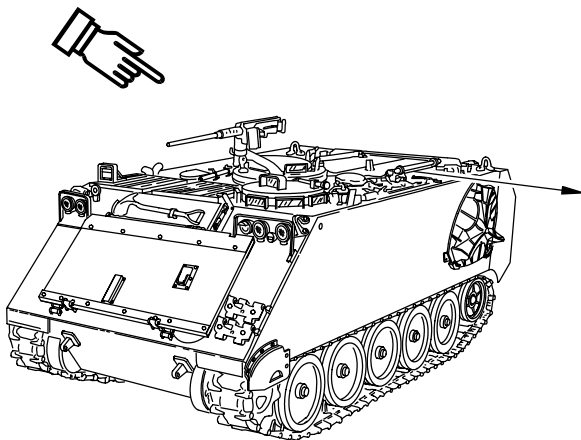

PREVENTIVE MAINTENANCE CHECKS AND SERVICES — Continued

0090 00

ITEM NO.	INTERVAL	MAN-HOUR	ITEM TO BE CHECKED OR SERVICED	CREWMEMBER PROCEDURE	EQUIPMENT NOT READY/ AVAILABLE IF:
74	After		Mortar Carrier (M1064A3 Only)	<p>CREWMEMBER</p> <p>a. See TM 9-1015-250-10 to conduct PMCS for 4.7 inch, 120-mm mortar.</p>	<p>Fault listed in "Not Fully Mission Capable If:" column of mortar TM.</p>
75	After		Ammo Racks, Door, Posts and Hinges (M1064A3 Only)	<p>CREWMEMBER</p> <p>a. Check ammo racks, door, posts, and hinges for cracks and breaks. Report damaged or missing ammo racks, hinges, door, or posts to unit maintenance.</p>	

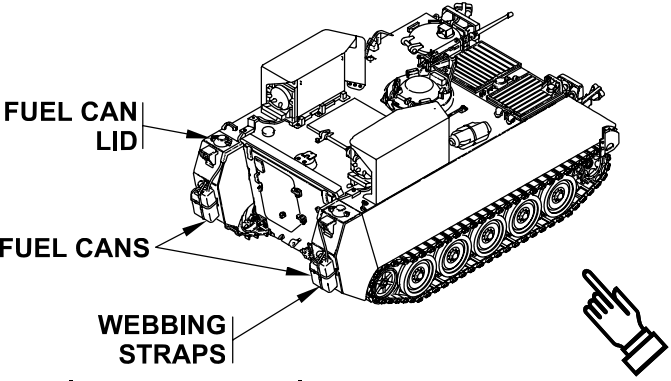
ITEM NO.	INTERVAL	MAN-HOUR	ITEM TO BE CHECKED OR SERVICED	CREWMEMBER PROCEDURE	EQUIPMENT NOT READY/ AVAILABLE IF:
76	After		M157A2 Smoke Generator System (M1059A3 Only)	<p>GENERATOR OPERATOR</p> <p>a. For PMCS procedures, see TM 3-1040-283-10.</p> <div style="text-align: center;"> <p>WARNING</p>  <p>Sparks from static electricity can cause a fire or explosion. Fuel cans should be removed before being filled. Metal nozzle must touch metal in filler neck when filling or ground wire must be attached to fuel can being filled. Fuel can catch fire and burn you. Do not smoke. Wipe up spilled fuel.</p> </div> <p>b. Check generator fuel cans.</p> <div style="text-align: center;">  </div>	<p>Fault listed in "Not Fully Mission Capable If:" column of smoke generator TM.</p>

PREVENTIVE MAINTENANCE CHECKS AND SERVICES — Continued

0090 00

ITEM NO.	INTERVAL	MAN-HOUR	ITEM TO BE CHECKED OR SERVICED	CREWMEMBER PROCEDURE	EQUIPMENT NOT READY/ AVAILABLE IF:
77	After		Smoke Obscurant System (M58 Only)	<p>GENERATOR OPERATOR</p> <p>a. For PMCS procedures, see TM 3-1040-285-10.</p>	<p>Fault listed in "Not Fully Mission Capable If:" column of smoke obscurant system TM.</p>
78	After		4.2 KW Generator System (M577A3 and M1068A3)	<p>CREWMEMBER</p> <p>a. Refer to TM 5-6115-596-14 for PMCS procedures.</p>	<p>Fault listed in "Not Fully Mission Capable If:" column of generator TM.</p>
79	After		5.0 KW Auxiliary Power Unit (APU) (M1068A3 Only)	<p>CREWMEMBER</p> <p>a. Refer to TM 9-6115-664-13&P for PMCS procedures.</p>	<p>Fault listed in "Not Fully Mission Capable If:" column of APU TM.</p>

PREVENTIVE MAINTENANCE CHECKS AND SERVICES — Continued

0090 00

ITEM NO.	INTERVAL	MAN-HOUR	ITEM TO BE CHECKED OR SERVICED	CREWMEMBER PROCEDURE	EQUIPMENT NOT READY/ AVAILABLE IF:
80	After		Mortar Fire Control System (MFCS) (M1064A3 and M577A3)	DRIVER/GUNNER/COMMANDER a. See TM 9-1220-248-10 to conduct PMCS for M1064A3 or TM 9-1220-249-10 to conduct PMCS for M577A3.	Fault listed in "Equipment Not Ready/ Available If:" column of MFCS TM.

Table 6. Preventive Maintenance Checks and Services for Model M113A3 FOV, Weekly

ITEM NO.	INTERVAL	MAN-HOUR	ITEM TO BE CHECKED OR SERVICED	CREWMEMBER PROCEDURE	EQUIPMENT NOT READY/ AVAILABLE IF:
81	Weekly		Power Plant Access Door and Trim Vane	<p style="text-align: center;">NOTE</p> <p>Do PREVENTIVE MAINTENANCE steps each week or before operation if you are operating the carrier for the first time.</p> <p>Carrier commander will direct and assist in weekly, monthly, and semi-annual PMCS.</p> <ol style="list-style-type: none"> a. Check that access door, door seal, and trim vane are serviceable. b. Check rubber seal for breaks, brittleness, cracks, and poor seating. c. Check access door for watertight fit. Make sure door locks. d. Check trim vane for cracks, warps, and separation of plywood. e. Operate trim vane control handle. Make sure adjustment is right in both the stowed and open position. 	Access door will not close and lock.

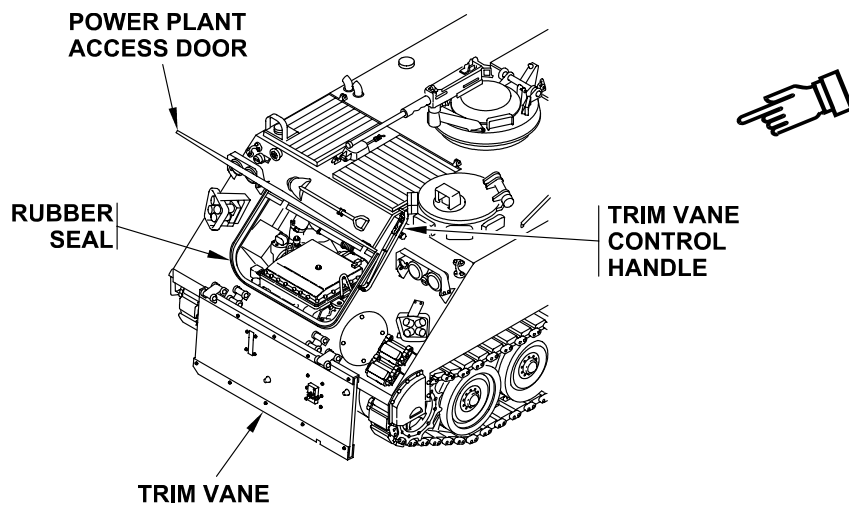

PREVENTIVE MAINTENANCE CHECKS AND SERVICES — Continued

0090 00

ITEM NO.	INTERVAL	MAN-HOUR	ITEM TO BE CHECKED OR SERVICED	CREWMEMBER PROCEDURE	EQUIPMENT NOT READY/ AVAILABLE IF:
82	Weekly		Engine Exhaust System	<p style="text-align: center;">NOTE</p> <p>Check for exhaust leaks only after engine reaches normal operating temperature of 160° to 200° F (71.1° to 93.3° C). Carrier leaks exhaust gas when cold. For this reason, carbon will be present around joints and exhaust pipe connecting clamps. This is normal. The exhaust system joints will seal after pipes heat up.</p> <p>a. Check complete exhaust system for deterioration, damage, or evidence of exhaust leakage at connection points. Look for weld failures and loose or missing hardware. Notify unit maintenance of defects.</p>	Any part missing, damaged, improperly aligned, or insecurely mounted.

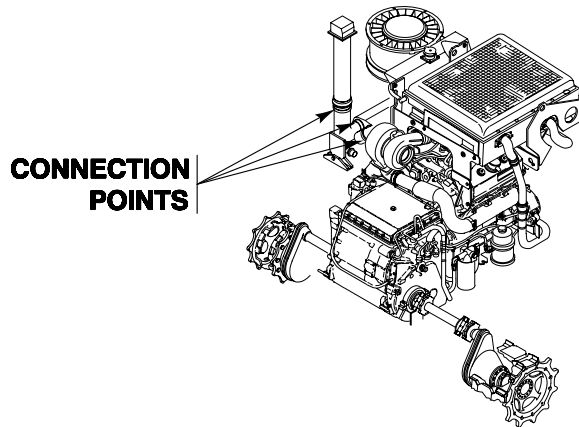

ITEM NO.	INTERVAL	MAN-HOUR	ITEM TO BE CHECKED OR SERVICED	CREWMEMBER PROCEDURE	EQUIPMENT NOT READY/ AVAILABLE IF:
83	Weekly		Air Cleaner	<p style="text-align: center;">WARNING</p> <div style="text-align: center;">  </div> <p>Failure to decontaminate and wear protective clothing after NBC attack could result in serious health hazards to personnel. Do not service air cleaner or vent system after NBC attack until carrier has been decontaminated.</p> <p>If NBC exposure is suspected, all air filter media should be handled by personnel wearing protective equipment. Consult your unit NBC officer or NBC NCO for appropriate handling or disposal instructions.</p> <p>Unlatched hatch covers can swing and injure personnel. Make sure hatches are latched open or closed.</p> <p style="text-align: center;">CAUTION</p> <p>Operating carrier with air cleaner missing or damaged can cause extensive engine damage. Do not operate carrier if air cleaner element is missing or door or gasket is missing or damaged.</p> <p>a. Check air cleaner as follows:</p> <ol style="list-style-type: none"> 1) Check latch for proper operation. Release latch at top of air cleaner housing. Swing door up and remove door. 	<p>Air cleaner element, door, or gasket is missing or damaged.</p>

PREVENTIVE MAINTENANCE CHECKS AND SERVICES — Continued

0090 00

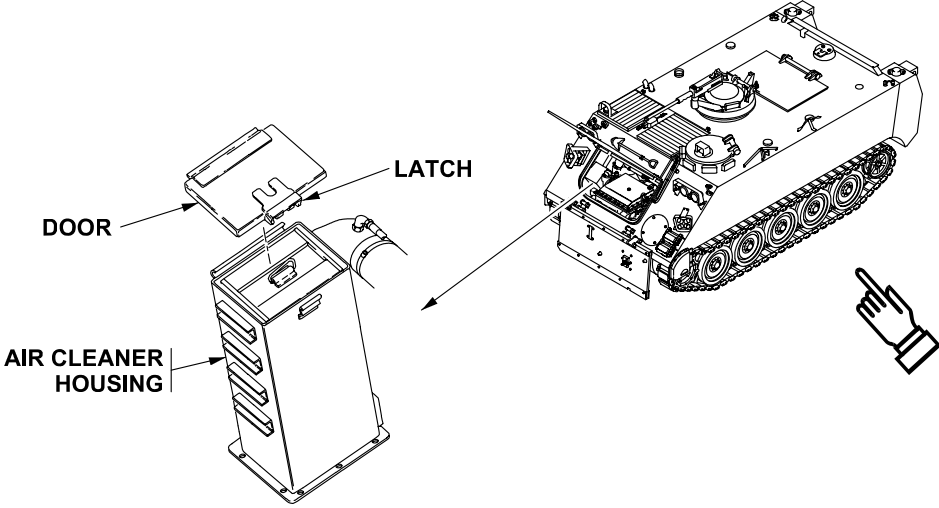
ITEM NO.	INTERVAL	MAN-HOUR	ITEM TO BE CHECKED OR SERVICED	CREWMEMBER PROCEDURE	EQUIPMENT NOT READY/ AVAILABLE IF:
				<p>2) Check door for missing or damaged gasket.</p> <p>3) Check that air cleaner element is installed in air cleaner housing.</p> 	

ITEM NO.	INTERVAL	MAN-HOUR	ITEM TO BE CHECKED OR SERVICED	CREWMEMBER PROCEDURE	EQUIPMENT NOT READY/ AVAILABLE IF:
84	Weekly	0.2	Final Drives Oil Level	<p style="text-align: center;">CAUTION</p> <p>Carrier must be on level surface when checking oil level. For access to left drive gauge rod, remove hull front access cover.</p> <p>a. Check oil in both final drives for level between ADD and FULL marks on gauge rod. Add applicable OE/HDO or OEA as specified in Lubrication Tables (page 0090 00-7). Do not overfill.</p>	Any Class III leak.

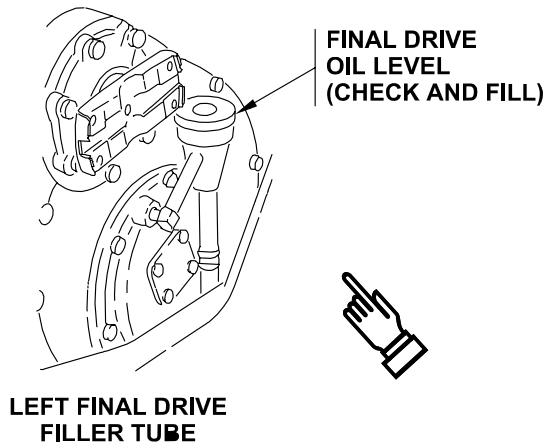
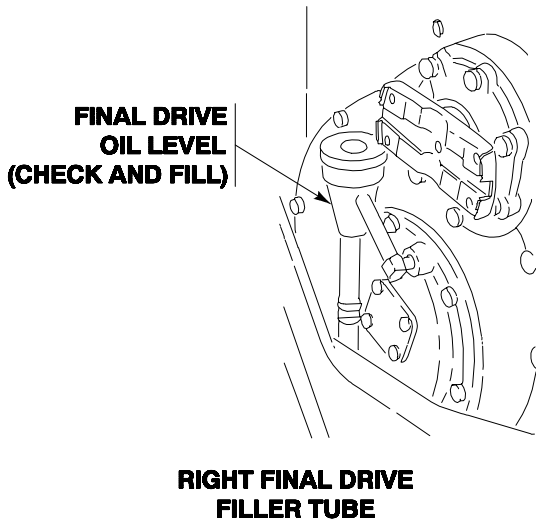
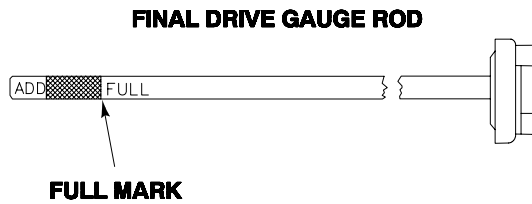
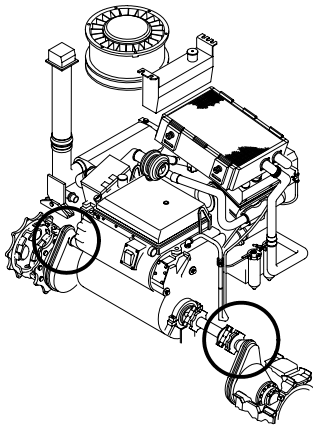

PREVENTIVE MAINTENANCE CHECKS AND SERVICES — Continued

0090 00

ITEM NO.	INTERVAL	MAN-HOUR	ITEM TO BE CHECKED OR SERVICED	CREWMEMBER PROCEDURE	EQUIPMENT NOT READY/ AVAILABLE IF:
85	Weekly		Lights	<p style="text-align: center;">NOTE</p> <p>Driver will turn on lights and crewmember will check for operation.</p> <ol style="list-style-type: none"> a. Turn MASTER SWITCH to ON and lift up on safety lock lever. b. Check service lights by turning driving lights switch on. Depress high-beam switch to make sure lights operate properly on high and low beams. 	

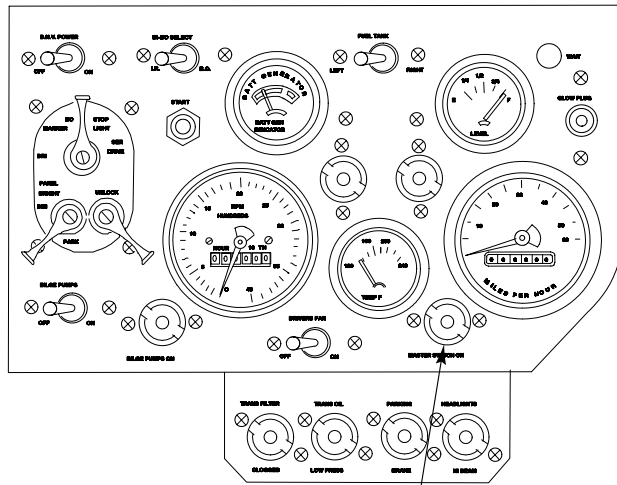
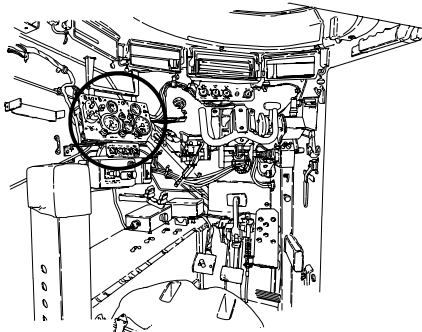

**MASTER SWITCH ON
INDICATOR LIGHT**

PREVENTIVE MAINTENANCE CHECKS AND SERVICES — Continued

0090 00

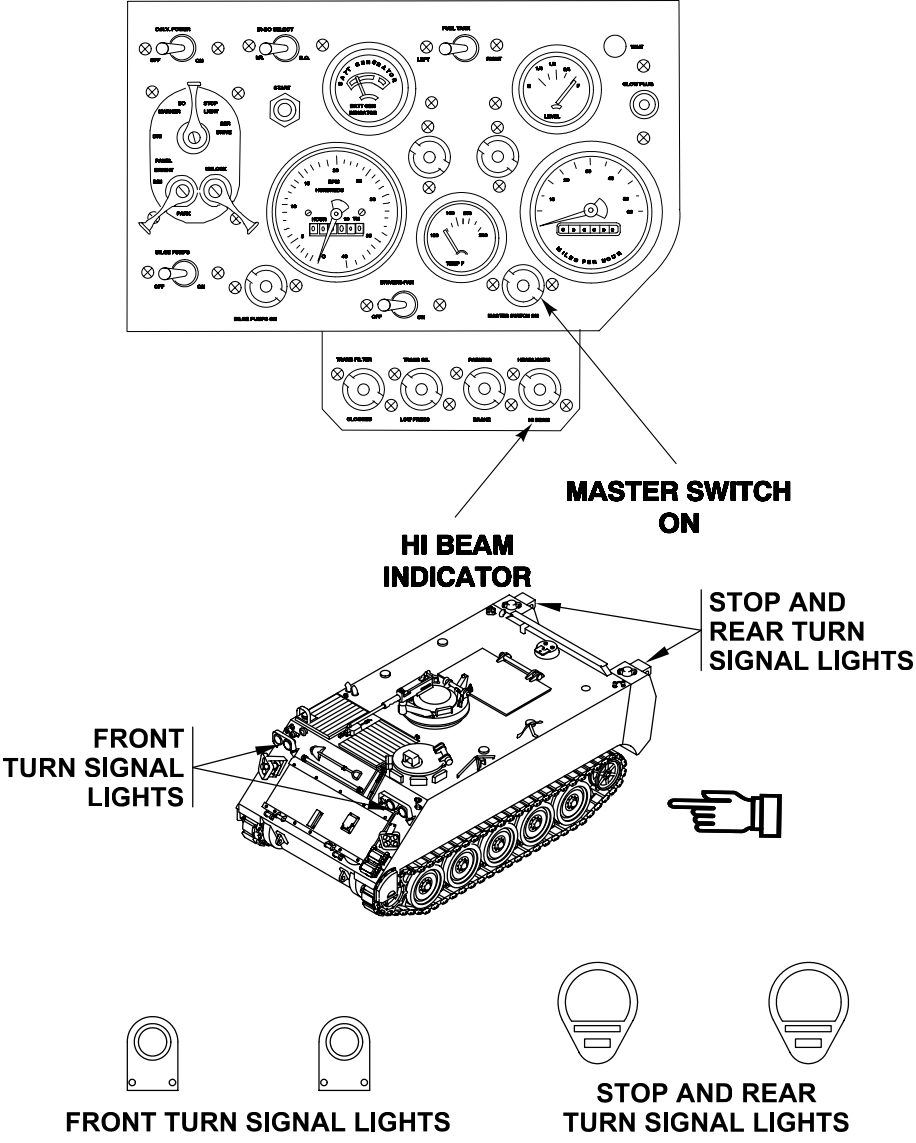
ITEM NO.	INTERVAL	MAN-HOUR	ITEM TO BE CHECKED OR SERVICED	CREWMEMBER PROCEDURE	EQUIPMENT NOT READY/ AVAILABLE IF:
				<p>c. <input type="checkbox"/> Check HI BEAM indicator light and MASTER SWITCH ON indicator light.</p> <p>d. Check that turn signals operate properly on both sides of carrier.</p> <div style="text-align: center;">  </div>	

PREVENTIVE MAINTENANCE CHECKS AND SERVICES — Continued

0090 00

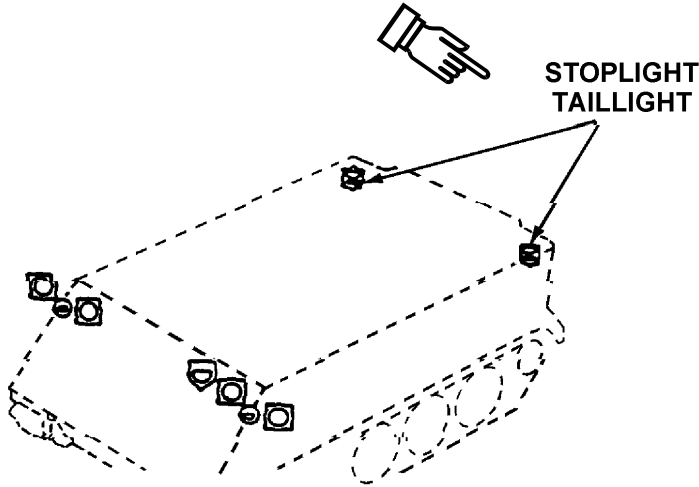
ITEM NO.	INTERVAL	MAN-HOUR	ITEM TO BE CHECKED OR SERVICED	CREWMEMBER PROCEDURE	EQUIPMENT NOT READY/ AVAILABLE IF:
				<p>e. Check stoplight and taillights to see that they operate properly. Make sure lights brighten during braking.</p> 	

ITEM NO.	INTERVAL	MAN-HOUR	ITEM TO BE CHECKED OR SERVICED	CREWMEMBER PROCEDURE	EQUIPMENT NOT READY/ AVAILABLE IF:
				<p style="text-align: center;">NOTE</p> <p>Blackout stoplight will light when brakes are applied.</p> <p>f. Check blackout drive lights by turning light switch lever to B.O. DRIVE and moving I.R.-B.O. SELECT switch to B.O. Blackout headlights and four blackout marker lights will light.</p>	

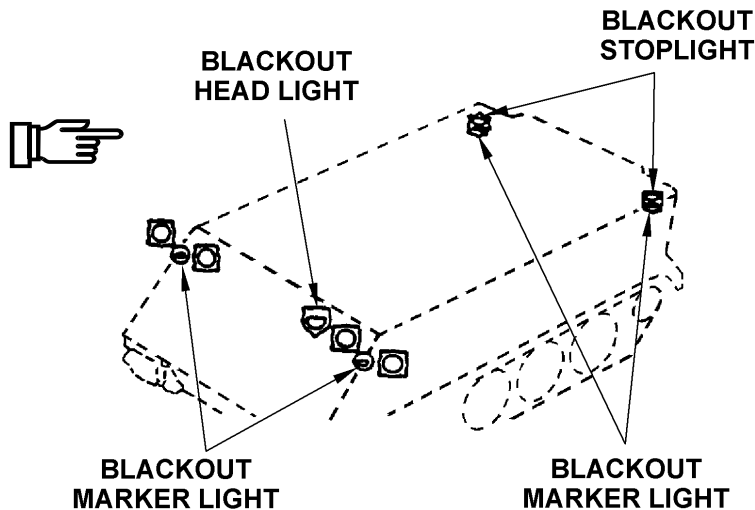
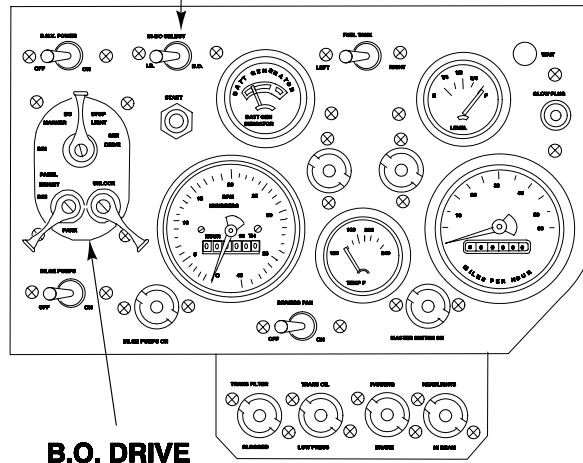
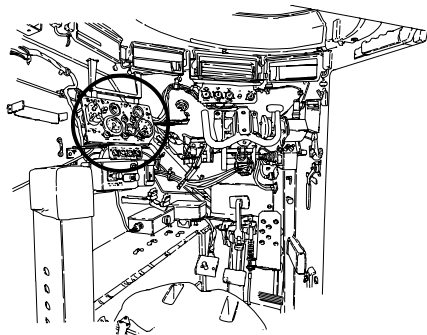

I.R.-B.O. SELECT SWITCH

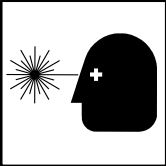
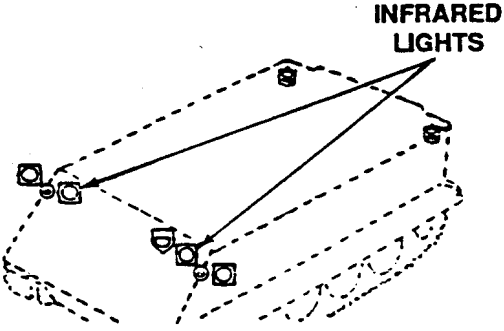

ITEM NO.	INTERVAL	MAN-HOUR	ITEM TO BE CHECKED OR SERVICED	CREWMEMBER PROCEDURE	EQUIPMENT NOT READY/ AVAILABLE IF:
				<p style="text-align: center;">WARNING</p> <div style="text-align: center;">  </div> <p>Do not look directly into infrared lights. You can damage your eyes. Do not touch lens. You can burn your fingers.</p> <p>g. Check infrared lights on both high and low beam. Do this by HOLDING YOUR HANDS OVER THE LENS, but do not touch the lens. If the light is operating properly, you will feel heat.</p> <div style="text-align: center;">  </div>	

PREVENTIVE MAINTENANCE CHECKS AND SERVICES — Continued

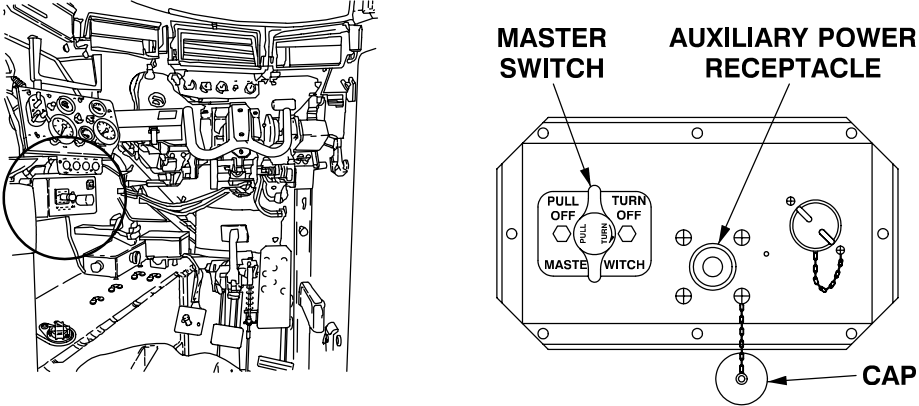
0090 00

ITEM NO.	INTERVAL	MAN-HOUR	ITEM TO BE CHECKED OR SERVICED	CREWMEMBER PROCEDURE	EQUIPMENT NOT READY/ AVAILABLE IF:
86	Weekly		Slave Cable and Receptacle	<p>a. Check slave cable, receptacle, and cap for damage, burnt-out condition, and corrosion.</p> 	
87	Weekly		Ramp and Ramp Door	<p>WARNING</p>  <p>Lowering ramp could injure personnel. Make sure no one is in ramp zone before you lower ramp. If tactical situation permits, sound horn before lowering ramp.</p> <p>a. Check ramp and ramp door for proper operation and seal.</p> <p>b. Check ramp door seal for breaks, brittleness, cracks, or poor seating.</p>	Ramp or ramp door will not seal.

ITEM NO.	INTERVAL	MAN-HOUR	ITEM TO BE CHECKED OR SERVICED	CREWMEMBER PROCEDURE	EQUIPMENT NOT READY/ AVAILABLE IF:
				<p>c. Check ramp wire rope for frayed or broken strands.</p> <p>d. Check ramp-to-hull seals for breaks, brittleness, cracks, or poor seating.</p> <p>e. Check ramp locks for proper operation and missing parts.</p> <p>M58 Only</p> <p>f. Make sure vision block is not missing or damaged enough to allow water into the vehicle.</p> <p>g. Check frame and glass for cracks and scratches that impair vision, or damage.</p>	<p>Ramp wire rope is frayed or broken.</p>
88	Weekly		Tow Pintle and Nut	<p>a. Check that cotter pin on tow pintle is present and properly secured.</p>	

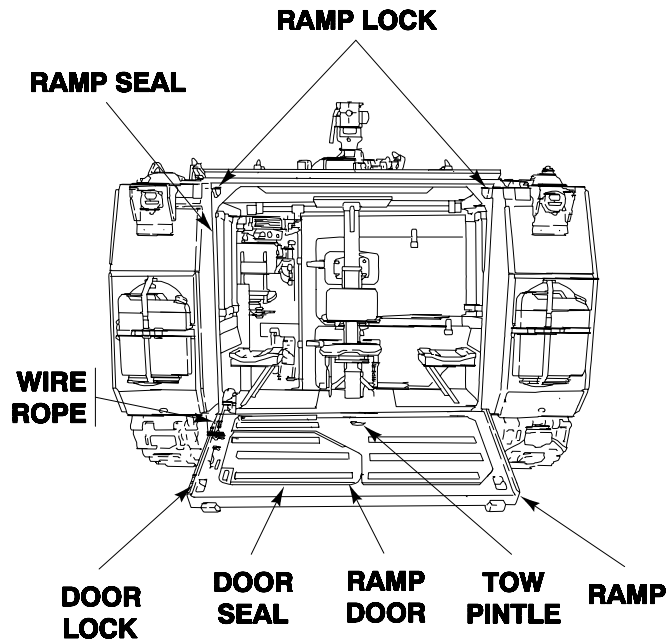

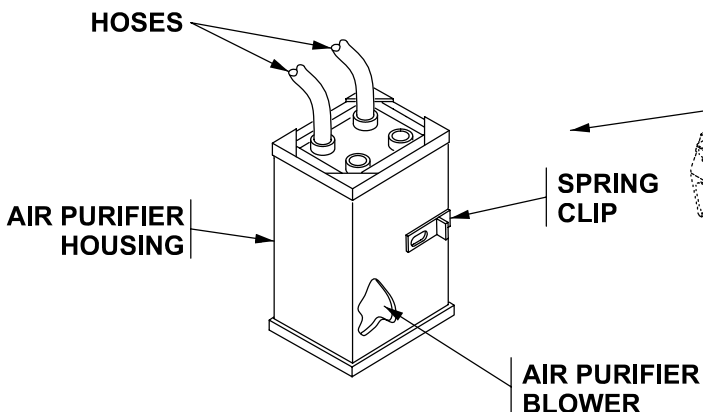
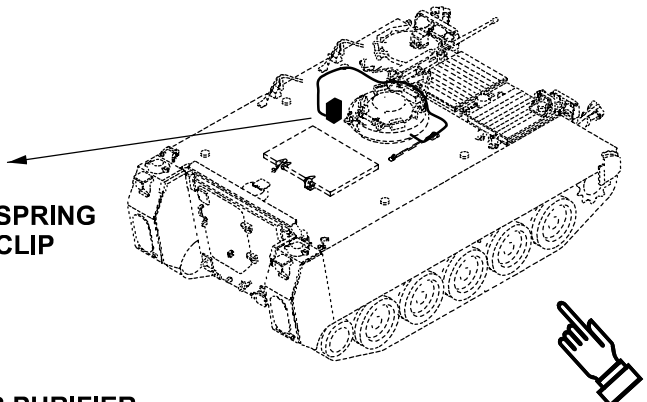
ITEM NO.	INTERVAL	MAN-HOUR	ITEM TO BE CHECKED OR SERVICED	CREWMEMBER PROCEDURE	EQUIPMENT NOT READY/ AVAILABLE IF:
89	Weekly		Gas Particulate Units	<p style="text-align: center;">NOTE</p> <p>Applies only to carriers equipped with gas particulate unit.</p> <p>a. Check gas particulate units as follows:</p> <ol style="list-style-type: none"> 1) Check air purifier housing for damage. Make sure spring clip is there. Check hoses for wear, cracks, and holes. Operate air purifier blower to make sure it operates properly. After blower is operating, place hand over air flow control cap. You should feel a flow of air at center hole. 	
					
				<p style="text-align: center;">NOTE</p> <p>Location of gas particulate units vary for each vehicle.</p> <ol style="list-style-type: none"> 2) Check air purifier housing for damage. Make sure spring clip is there. 	<p>Blower does not operate properly. Air flow at any station is restricted.</p>

PREVENTIVE MAINTENANCE CHECKS AND SERVICES — Continued

0090 00

ITEM NO.	INTERVAL	MAN-HOUR	ITEM TO BE CHECKED OR SERVICED	CREWMEMBER PROCEDURE	EQUIPMENT NOT READY/ AVAILABLE IF:
				3) Check hoses for wear, cracks, and holes. Operate air purifier blower to make sure it operates properly (WP 0004 00). After blower is operating, place hand over air flow control cap. You should feel a flow of air at center hole.	Any hole in hose or hoses.

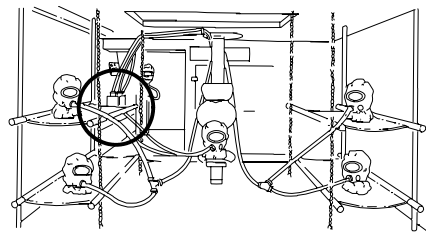

SPRING CLIP

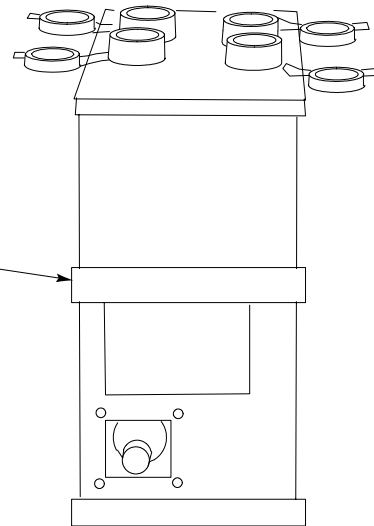

SOLID CAP

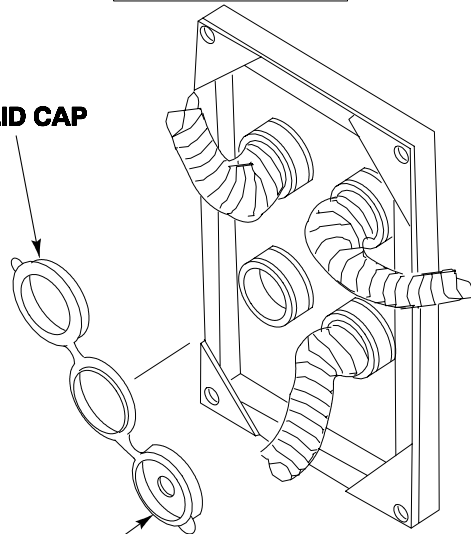

AIR PURIFIER SWITCH

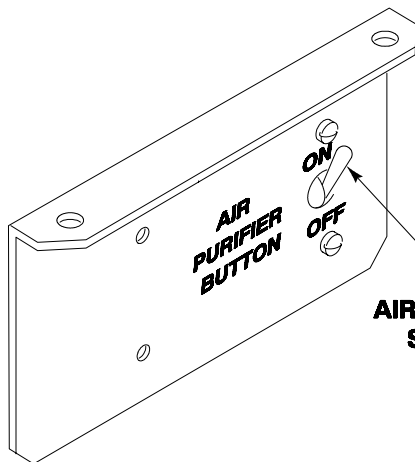

CAP WITH HOLE

ITEM NO.	INTERVAL	MAN-HOUR	ITEM TO BE CHECKED OR SERVICED	CREWMEMBER PROCEDURE	EQUIPMENT NOT READY/ AVAILABLE IF:
90	Weekly		M17 Periscope	<p style="text-align: center;">CAUTION</p> <p>Handle periscope carefully during removal to avoid damaging the frame and glass of the periscope.</p> <p style="text-align: center;">NOTE</p> <p>There are no periscopes on the M577A3 and M1068A3 commander's hatch.</p> <ol style="list-style-type: none"> a. Remove periscope by loosening two thumbscrews. b. Check between carrier wall and periscope for dirt or moisture. 	Over 50% vision obstructed.

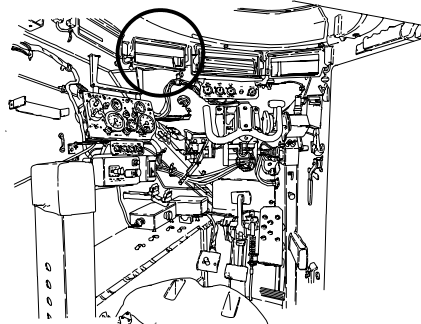
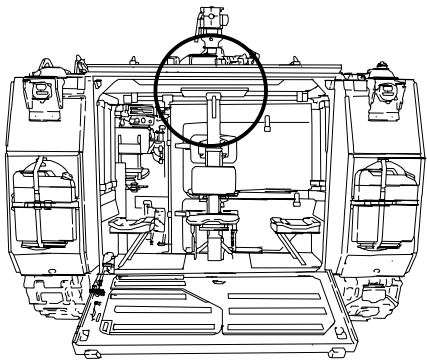

M17 PERISCOPE

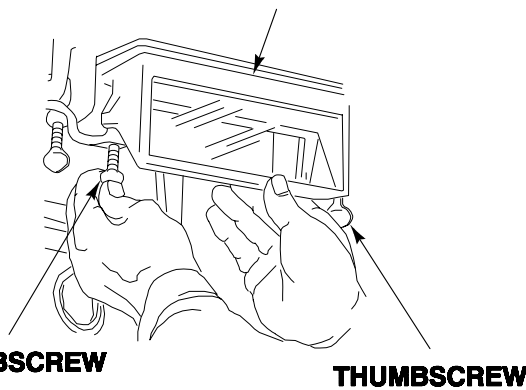

THUMBSCREW

THUMBSCREW

PREVENTIVE MAINTENANCE CHECKS AND SERVICES — Continued

0090 00

ITEM NO.	INTERVAL	MAN-HOUR	ITEM TO BE CHECKED OR SERVICED	CREWMEMBER PROCEDURE	EQUIPMENT NOT READY/ AVAILABLE IF:
91	Weekly		AN/VVS-2 Driver's Night Vision (DNV)	<p style="text-align: center;">WARNING</p>  <p>HIGH VOLTAGE in the AN/VVS-2 can cause serious injury or death. To avoid accidents:</p> <p>ALWAYS connect power cable to DNV BEFORE turning MASTER SWITCH and DNV POWER switch to ON.</p> <p>ALWAYS wait at least two minutes BEFORE you disconnect power cable from periscope when turning DNV POWER switch and MASTER SWITCH to OFF.</p> <p>NEVER disconnect power cable from DNV until image disappears from periscope screen.</p> <p>NEVER touch end of cable. Voltage could exceed 16,000 volts.</p> <p style="text-align: center;">CAUTION</p> <p>Do not expose this instrument to direct sunlight during inspection. Direct sunlight or large amounts of light will damage the AN/VVS-2 DNV.</p>	

PREVENTIVE MAINTENANCE CHECKS AND SERVICES — Continued

0090 00

ITEM NO.	INTERVAL	MAN-HOUR	ITEM TO BE CHECKED OR SERVICED	CREWMEMBER PROCEDURE	EQUIPMENT NOT READY/ AVAILABLE IF:
				<p>a. Check DNV for damage. Make sure DNV operates properly. Make sure you can see through DNV. Make sure MASTER SWITCH and DNV POWER switch are in off position.</p>	<p>Inoperative and no other night sight available.</p>

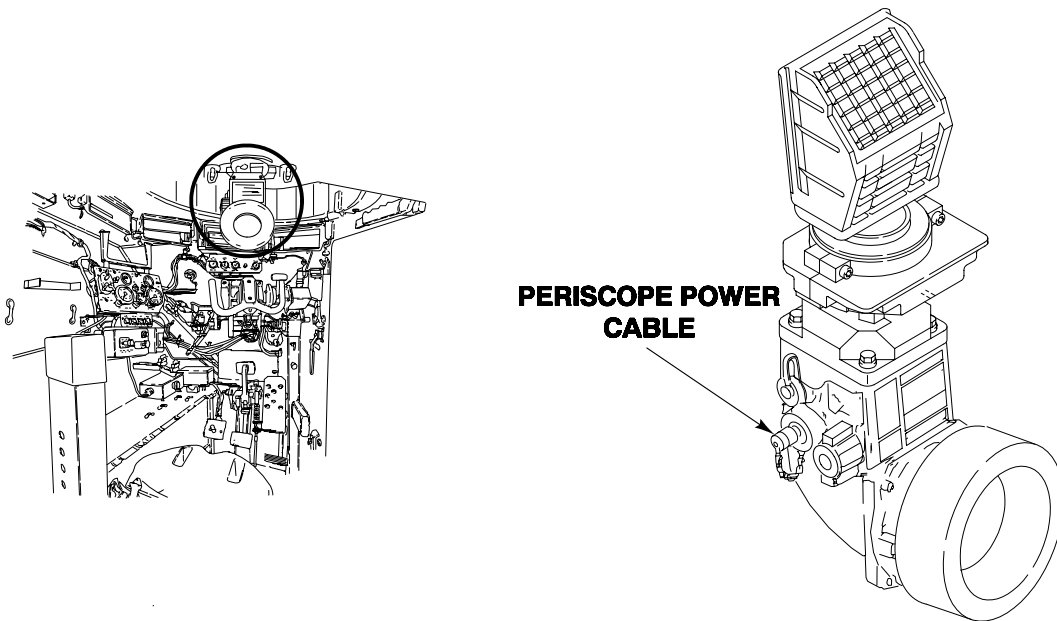

POWER SWITCH **DRIVING LIGHTS SWITCH**

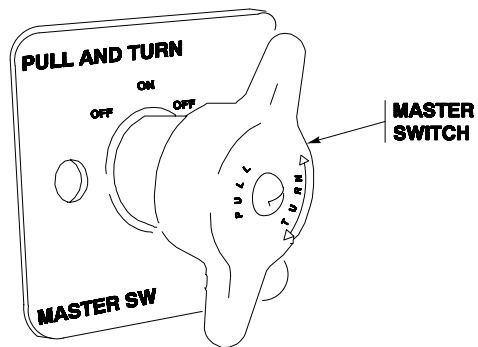
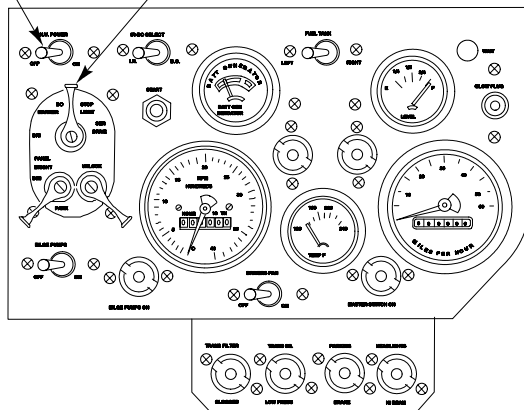

PREVENTIVE MAINTENANCE CHECKS AND SERVICES — Continued

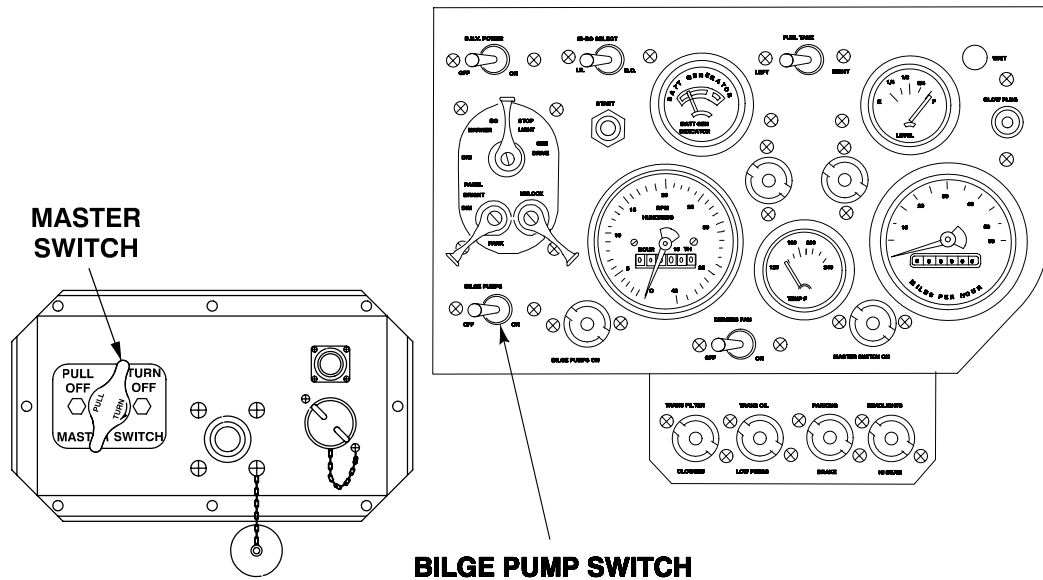

0090 00

ITEM NO.	INTERVAL	MAN-HOUR	ITEM TO BE CHECKED OR SERVICED	CREWMEMBER PROCEDURE	EQUIPMENT NOT READY/ AVAILABLE IF:
92	Weekly		Bilge Pumps	<p>b. Check power cable electrical connector for bent or missing pins or bare wires. Report damaged connector to unit maintenance. Attach power cable to DNV receptacle.</p> <p style="text-align: center;">NOTE</p> <p>Rear bilge pump is below rear floor plate. Front bilge pump is in left front corner of power plant compartment.</p> <p>a. Check bilge pumps weekly and before any water operations as follows:</p> <ol style="list-style-type: none"> 1) Turn MASTER SWITCH to ON. 2) Turn BILGE PUMPS switch to ON. Make sure front and rear bilge pump lights are on. 	

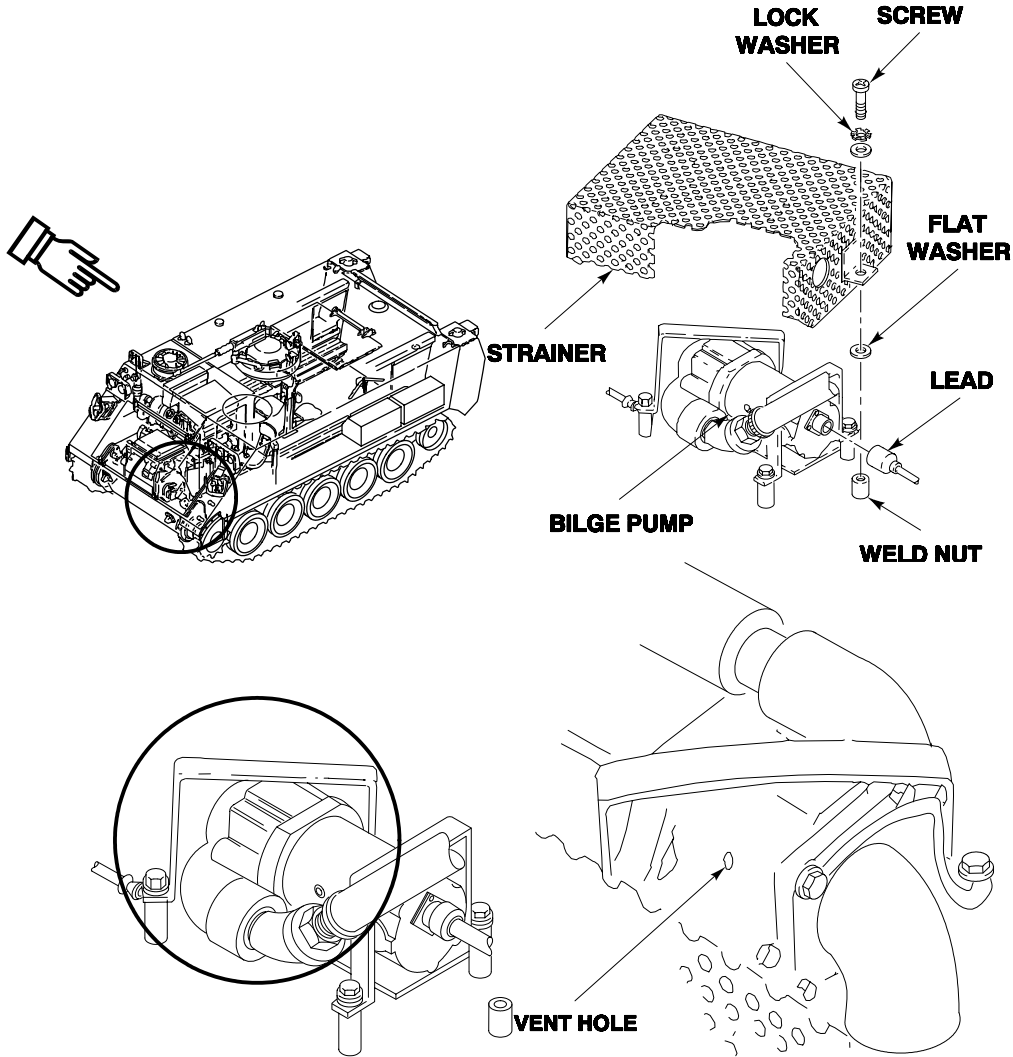

ITEM NO.	INTERVAL	MAN-HOUR	ITEM TO BE CHECKED OR SERVICED	CREWMEMBER PROCEDURE	EQUIPMENT NOT READY/ AVAILABLE IF:
				<p>3) Feel bilge pump outlet for a stream of water if there is water in the carrier, or feel for a stream of air if water is absent.</p> <div data-bbox="500 577 1084 1239" style="text-align: center;"> <p>REAR BILGE PUMP OUTLET</p> <p>FORWARD BILGE PUMP OUTLET</p> </div> <p>4) Check bilge pump intake screens and pump vent holes for clogging. Clear screen of all trapped debris. Clear pump vent holes by running a wire in and out. For complete description on servicing bilge pumps see WP 0096 00.</p> <p>5) Check bilge pump sight glass in driver's compartment. If fluid in sight is visible, operate bilge pump to remove fluid.</p>	<p>Pumps do not operate properly. Any Class III leak.</p>

ITEM NO.	INTERVAL	MAN-HOUR	ITEM TO BE CHECKED OR SERVICED	CREWMEMBER PROCEDURE	EQUIPMENT NOT READY/ AVAILABLE IF:
					

ITEM NO.	INTERVAL	MAN-HOUR	ITEM TO BE CHECKED OR SERVICED	CREWMEMBER PROCEDURE	EQUIPMENT NOT READY/ AVAILABLE IF:
93	Weekly		Batteries	<p style="text-align: center;">WARNING</p> <div style="display: flex; justify-content: space-around;">   </div> <p>Don't smoke, have open flames, or make sparks around batteries, especially if the caps are off. Batteries can explode and cause injury or death.</p> <p>Remove all jewelry such as rings, dog tags, bracelets, etc. If jewelry contacts battery terminals, a direct short will result in instant heating of metals, damage to equipment, and injury to personnel.</p> <p>If batteries are frozen, do NOT attempt to slave start vehicle. Explosion can occur causing injury to personnel and damage to equipment.</p> <p style="text-align: center;">CAUTION</p> <p>In cold weather, unit maintenance must charge batteries immediately after adding water. This allows water to combine with electrolyte and prevent freezing.</p> <ol style="list-style-type: none"> a. Check electrolyte level in carrier batteries (WP 0095 00). b. Check that vent holes in caps are clear before installing caps. 	<p>Battery missing or damaged.</p>

PREVENTIVE MAINTENANCE CHECKS AND SERVICES — Continued

0090 00

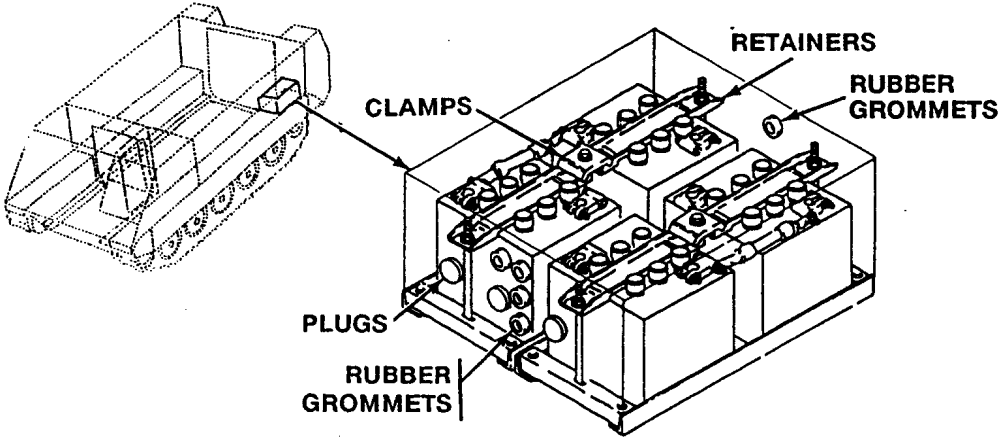
ITEM NO.	INTERVAL	MAN-HOUR	ITEM TO BE CHECKED OR SERVICED	CREWMEMBER PROCEDURE	EQUIPMENT NOT READY/ AVAILABLE IF:
				<ul style="list-style-type: none"> c. Check that battery cables and terminals are clean and connections are tight. d. Check that hold-down clamps and retainer are tight (WP 0095 00). e. Check that rubber grommets are on battery compartments. Notify unit maintenance if grommets are missing. 	<p>Obvious damage or looseness to battery, terminal, cable, or retainer.</p>
 <p style="text-align: center;">M58 SHOWN</p>					

PREVENTIVE MAINTENANCE CHECKS AND SERVICES — Continued

0090 00

ITEM NO.	INTERVAL	MAN-HOUR	ITEM TO BE CHECKED OR SERVICED	CREWMEMBER PROCEDURE	EQUIPMENT NOT READY/ AVAILABLE IF:
94	Weekly		Hatch	<p>a. Check carrier hatches for movement, locking, and sealing.</p> <p>b. Check personnel carrier cargo hatch. Make sure hatch opens and closes smoothly and can be tightly secured in both open and closed positions.</p>	Latches on any hatch that do not hold hatch in open or closed position. Any hatch locking pins missing or inoperable.

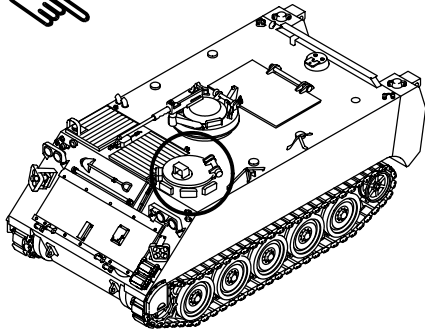

LOCKING PIN

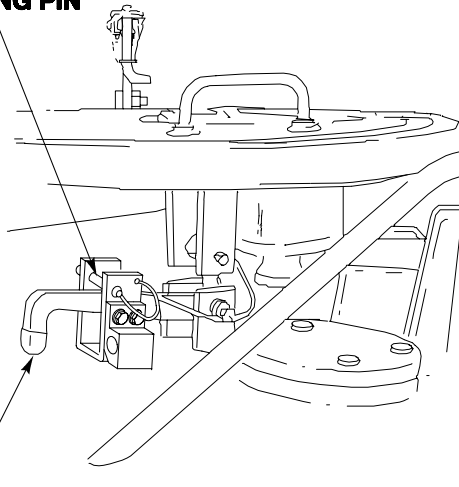

OUTSIDE HOOK

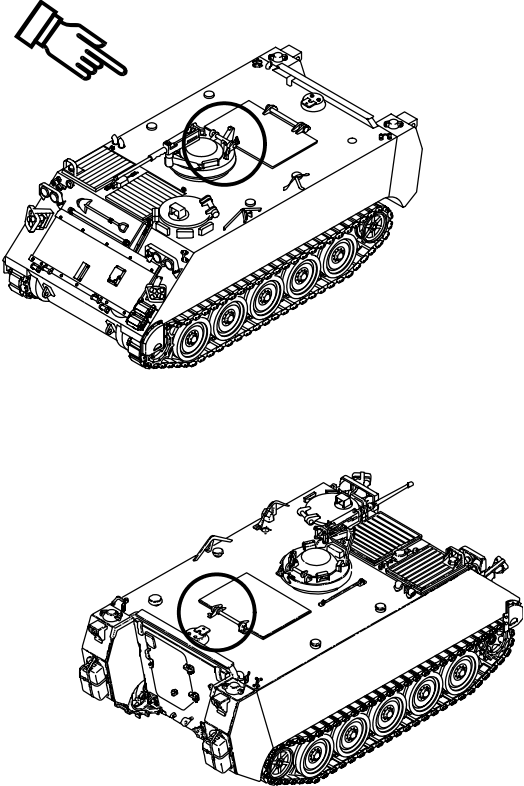
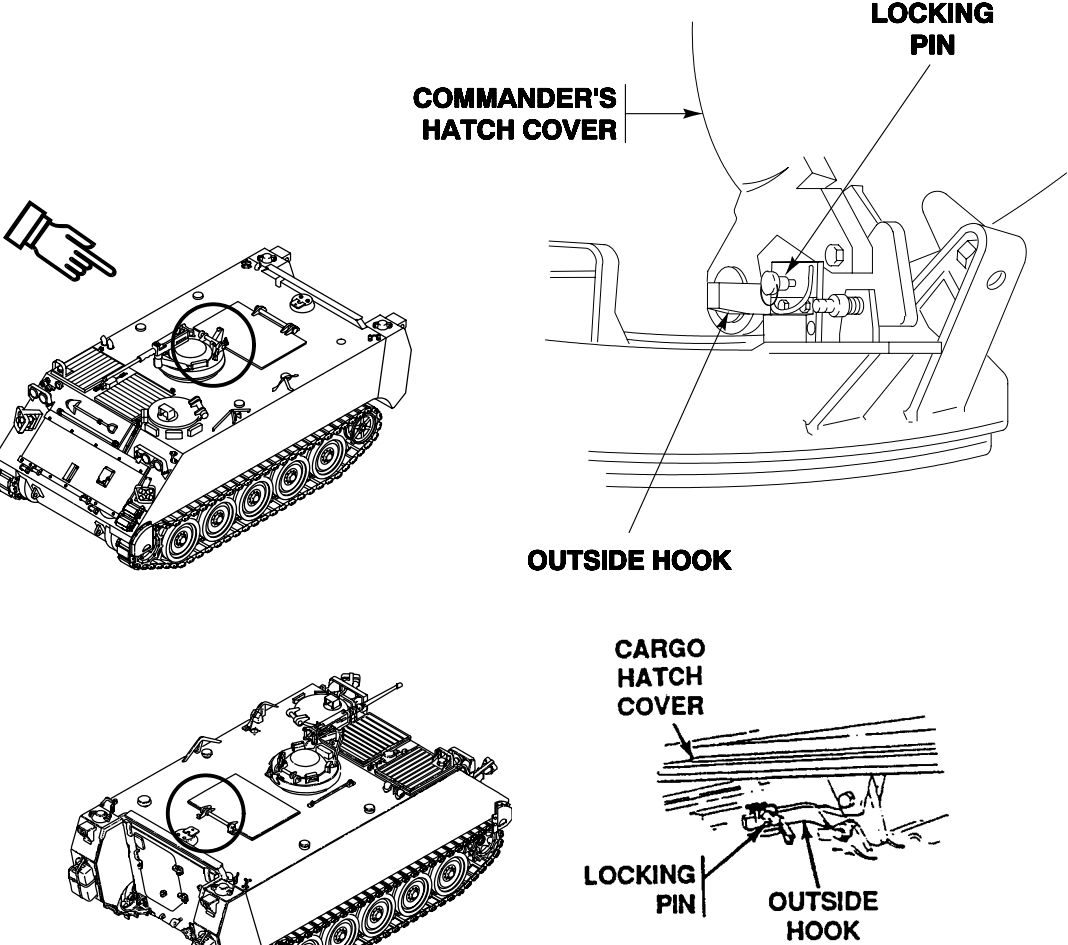
ITEM NO.	INTERVAL	MAN-HOUR	ITEM TO BE CHECKED OR SERVICED	CREWMEMBER PROCEDURE	EQUIPMENT NOT READY/AVAILABLE IF:
					

PREVENTIVE MAINTENANCE CHECKS AND SERVICES — Continued

0090 00

ITEM NO.	INTERVAL	MAN-HOUR	ITEM TO BE CHECKED OR SERVICED	CREWMEMBER PROCEDURE	EQUIPMENT NOT READY/ AVAILABLE IF:
95	Weekly		Trailer Light Receptacle	a. Check trailer light receptacle cable for damage. Check receptacle for damage and corrosion.	

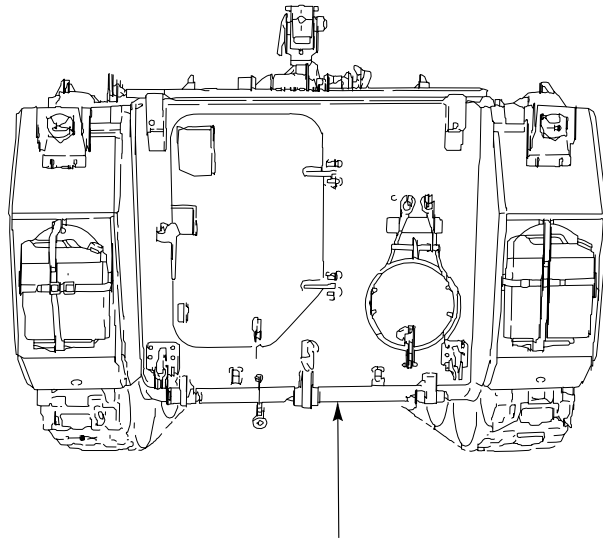

TRAILER LIGHT RECEPTACLE CABLE

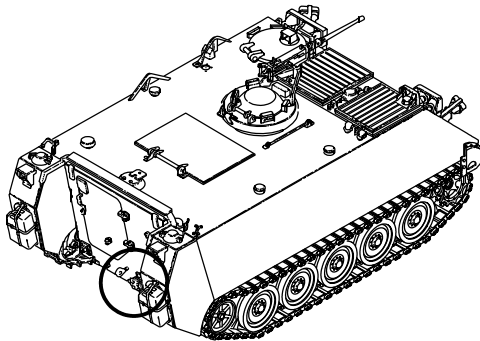

TRAILER LIGHT RECEPTACLE

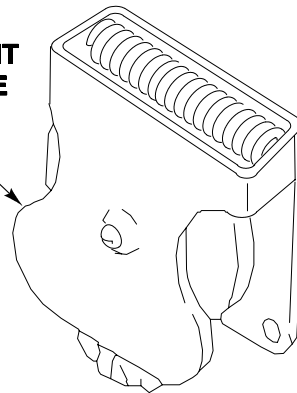

PREVENTIVE MAINTENANCE CHECKS AND SERVICES — Continued

0090 00

ITEM NO.	INTERVAL	MAN-HOUR	ITEM TO BE CHECKED OR SERVICED	CREWMEMBER PROCEDURE	EQUIPMENT NOT READY/ AVAILABLE IF:
96	Weekly		Slave Receptacle, Cable, and Generator	<p style="text-align: center;">NOTE</p> <p>Make sure slave receptacle cap on M577A3 and M1068A3 is secure. Report damage to unit maintenance.</p> <ol style="list-style-type: none"> a. Check receptacle and cable for damage, burn-out condition, and corrosion. b. Check that volts are in the green zone of voltmeter. c. Check generator set for mud, dirt, and excess oil and grease. Clean as required. 	<p>Receptacle or cable damaged, burnt-out, or missing.</p> <p>Voltage meter not in the green zone.</p> <p>Generator set missing or inoperative.</p>

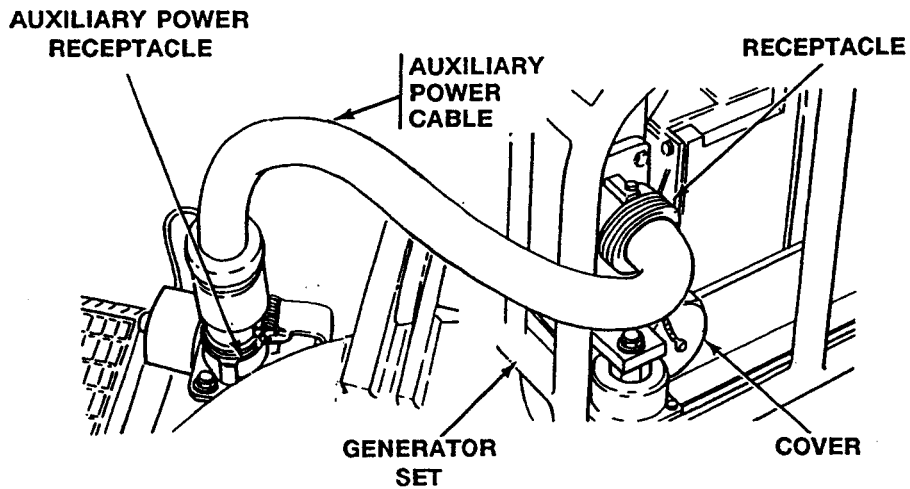

PREVENTIVE MAINTENANCE CHECKS AND SERVICES — Continued

0090 00

ITEM NO.	INTERVAL	MAN-HOUR	ITEM TO BE CHECKED OR SERVICED	CREWMEMBER PROCEDURE	EQUIPMENT NOT READY/ AVAILABLE IF:
97	Weekly		External Power Entry Box (M1068A3 Only)	<p>a. Check to ensure plug caps are secure and chains are not broken.</p> <p>b. Check for external damage.</p> <p>c. Make sure unit locks properly.</p> <div data-bbox="662 663 964 1079" data-label="Image"> <p>The diagram shows a perspective view of a rectangular metal box. The top lid is hinged and is shown in an open position. An arrow points to the lid with the label 'EXTERNAL POWER ENTRY BOX'. Another arrow points to a circular cap on the front face of the box with the label 'CAP'. A third arrow points to two metal chains attached to the front of the box with the label 'CHAINS'.</p> </div>	

Table 7. Preventive Maintenance Checks and Services for Model M113A3 FOV, Monthly

ITEM NO.	INTERVAL	MAN-HOUR	ITEM TO BE CHECKED OR SERVICED	CREWMEMBER PROCEDURE	EQUIPMENT NOT READY/AVAILABLE IF:
98	Monthly	0.3	Fan Gearbox Oil Level	a. Check oil level in sight glass of fan gearbox. Oil level must be to center of sight glass. Add oil as needed. See Lubrication Tables (Table 2, page 0090 00-8).	Any sign of Class III leak. No sign of oil in sight glass, or oil is contaminated.

Table 8. Preventive Maintenance Checks and Services for Model M113A3 FOV, Semi-annually

ITEM NO.	INTERVAL	MAN-HOUR	ITEM TO BE CHECKED OR SERVICED	CREWMEMBER PROCEDURE	EQUIPMENT NOT READY/ AVAILABLE IF:
99	Semi-annually	0.3	Tow Cable	a. Every 1500 miles or semi-annually and after each use, clean and lubricate tow cable with wire brush and grease. See Lubrication Tables (Table 2, page 0090 00-8). Wipe off excess grease.	
100	Semi-annually	0.3	Ramp Wire Rope	a. Every 1500 miles or semi-annually, clean and lubricate ramp wire rope as follows: 1) Lower ramp. Clean and lubricate exposed portion of wire rope with grease. See Lubrication Tables (Table 2, page 0090 00-8). 2) Remove rear floor plate and raise ramp. Clean and lubricate concealed portion of wire rope with grease. See Lubrication Tables (Table 2, page 0090 00-8).	
101	Semi-annually	0.3	Machine Gun Mount	a. Every 1500 miles or semi-annually, clean machine gun mount with cleaning compound (WP 0104 00, Item 6) and lubricate all moving parts with PL-M or PL-S as appropriate. See Lubrication Tables (Table 2, page 0090 00-8).	

ADJUST T130 TRACK TENSION

0091 00

THIS WORK PACKAGE COVERS:

Adjust Track Tension (page 0091 00-1).

INITIAL SETUP:

Maintenance Level

Operator

Personnel Required

Driver

Soldier

Tools and Special Tools

Drive Pin Punch (WP 0102 00, Table 2, Item 44)

Lubrication Gun (WP 0102 00, Table 2, Item 25)

Open End Wrench, 5/8 inch (WP 0102 00, Table 2 Item 63)

Track and Sprocket Gauge (WP 0102 00, Table 2, Item 24)

References

WP 0021 00

WP 0023 00

WP 0024 00

Equipment Condition

Engine stopped (WP 0024 00)

ADJUST TRACK TENSION

WARNING



Not having the correct track tension during inspection can cause you to not see defective track parts that could cause track failure and loss of vehicle control. Soldiers can be killed or injured.

Adjust track tension before inspecting track assembly and track shoes.

1. Start engine (WP 0021 00).
2. Drive carrier slowly to firm level ground (WP 0023 00).

WARNING



Do not shift to SL (Steering Lock) position at speeds above 5 mph. Loss of control at speeds above 5 mph could cause vehicle to crash.

3. Let carrier coast to a stop. Do not use steering wheel or press brake pedal to stop carrier. Place transmission controller in SL (Steering Lock) position to coast to a stop
4. Stop engine (WP 0024 00).

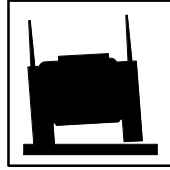
WARNING

Improper number of track shoes may prevent track from being adjusted correctly, creating a safety hazard.

For carriers with new track, ensure there are 63 track shoes on the left side of carrier and 64 track shoes on the right side of carrier.

For carriers with old track, ensure there are 62 track shoes on the left side of carrier and 63 track shoes on the right side of carrier.

NOTE

Either drive pin punch or track and sprocket gauge may be used to check track tension. If using drive pin punch, perform Steps 5 - 6. If using track and sprocket gauge, perform Steps 7 - 8.

- To check track tension using drive pin punch, insert drive pin punch between top of number two road wheel and bottom of track. If drive pin punch can be inserted freely, and track touches top of number three road wheel, track tension is correct.

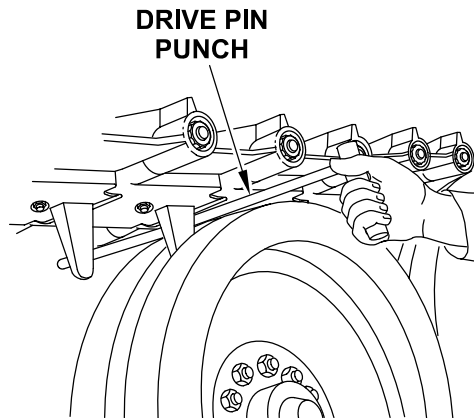
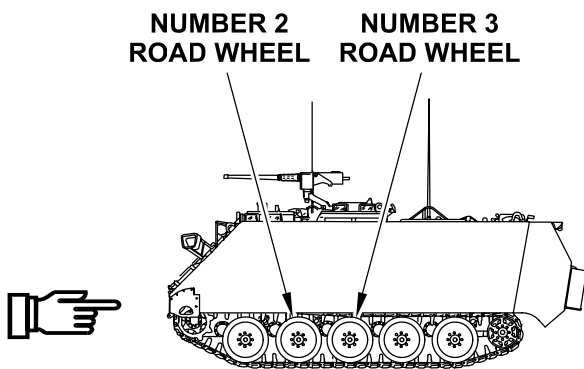

- If drive pin punch can be inserted freely but track does not touch top of number three road wheel, track tension is too tight. Loosen track tension (Step 10). If drive pin punch cannot be inserted freely, track tension is too loose. Tighten track tension (Step 9).

- To check track tension using track and sprocket gauge, position gauge lightly against bottom of track at centerline of second road wheel. Look through hole in gauge. If top of second road wheel can be seen (3/8 to 5/8 inch) and track touches number three road wheel, track tension is correct.

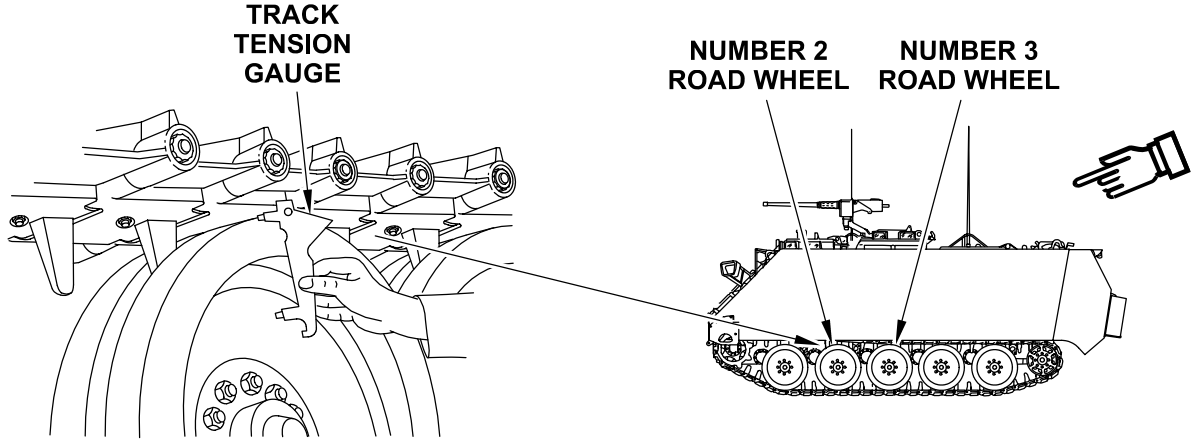

- If top of second road wheel cannot be seen or track does not touch number three road wheel, track need adjusting. To tighten track tension go to Step 9. To loosen track tension go to Step 10.

CAUTION

Dirt can damage fitting and cylinder. Clean all dirt from fittings on track tension adjuster.

Servicing the fitting can damage the track adjuster, idler wheel, and final drive bearings. Track adjuster fitting is not a true lubrication point. Do not service when lubricating the carrier.

Track adjuster can be damaged during carrier operation. Do not extend adjuster beyond 17 inches (43 cm).

- To tighten track tension add grease through fitting on track adjuster. If track adjuster is extended to its maximum limit of 17 inches (43 cm) and track is still too loose, remove one track shoe. See WP 0093 00 and readjust track tension (Steps 5 - 9).

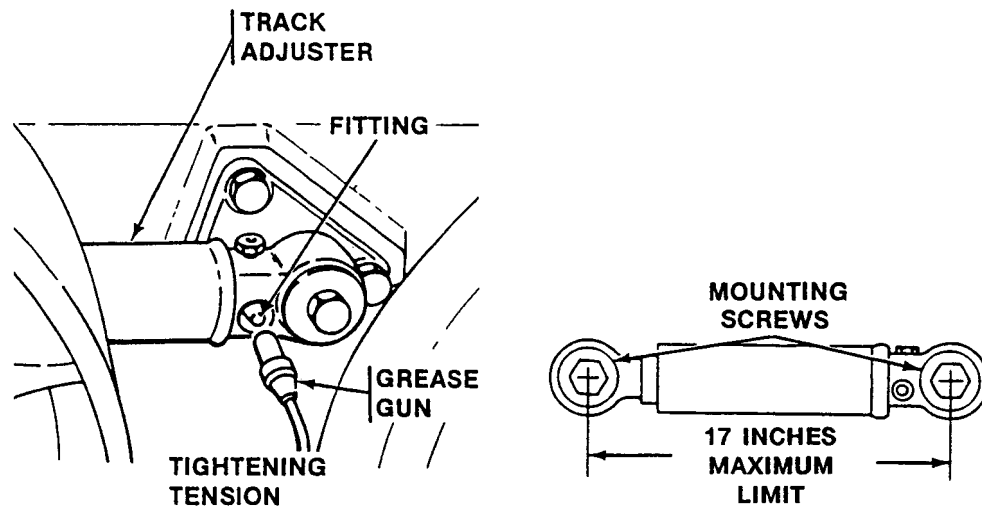

10. To loosen track tension, slowly open bleed valve on track tension adjuster to let grease out. Wipe up excess grease. If track adjuster is in as far as it will go, and track is still too tight, add one track shoe (WP 0093 00) and readjust track tension (Steps 5 - 9).

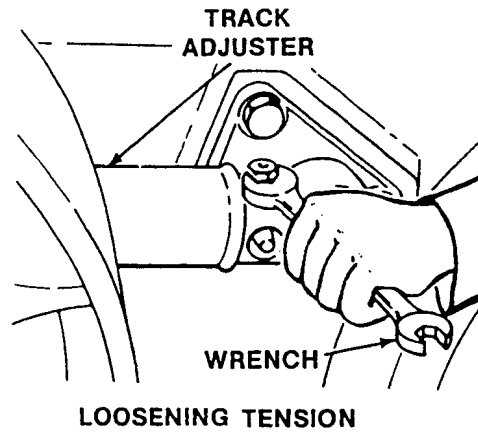

END OF TASK

ADJUST (T150) TRACK TENSION

0091 01

THIS WORK PACKAGE COVERS:Adjust Track Tension (page 0091 01-1)

INITIAL SETUP:Maintenance Level

Operator

Personnel Required

Driver

Soldier

Tools and Special Tools

Grease Gun (WP 0102 00, Item 25)

Open End Wrench, 5/8 inch (WP 0102 00, Item 63)

Track Gauge (WP 0102 00, Item 24A)

Equipment ConditionEngine stopped (WP 0024 00)

ADJUSTMENT**ADJUST TRACK TENSION**

1. Start engine (WP 0021 00).
2. Drive carrier slowly to firm level ground (WP 0023 00).

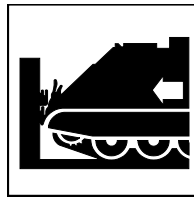
WARNING

Do not shift to SL (Steering Lock) position at speeds above 5 mph. Loss of control at speeds above 5 mph could cause vehicle to crash.

NOTE

Tension needs to be adjusted after mission when vehicle is completely unloaded of equipment and before mission after vehicle has been fully loaded.

3. Let carrier coast to a stop. Do not use steering wheel or press brake pedal to stop carrier. Place transmission controller in PV (Pivot) position to coast to a stop.
4. Stop engine (WP 0024 00).
5. Block track.

6. To check tension, position track tension gauge lightly between bottom of track and the third road wheel. Gauge should fit between bottom of track and top of road wheel.

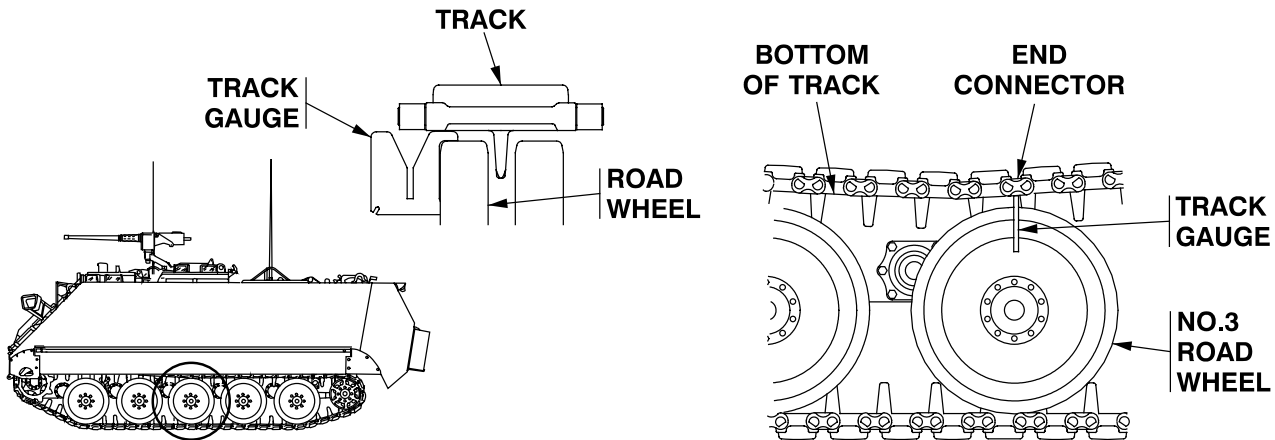

7. If gauge does not fit between bottom of track and top of road wheel, track tension is too loose; if gauge fits between track and road wheel, but is not touching both at the same time, track tension is too tight. To tighten track tension go to Step 8. To loosen track tension go to Step 9.

CAUTION

Dirt can damage fitting and cylinder. Clean all dirt from fittings on track tension adjuster. Servicing the fitting can damage the track adjuster, idler wheel and final drive bearings. Track adjuster fitting is not a true lubrication point. Do not service when lubricating the carrier.

8. To tighten track tension, add grease through fitting on track adjuster. If track adjuster is extended to its maximum limit of 17 inches and the track is still loose, remove one track shoe. See task: REMOVE/INSTALL (T150) TRACK SHOE (WP 0093 01) and readjust track tension Steps 5 - 9.

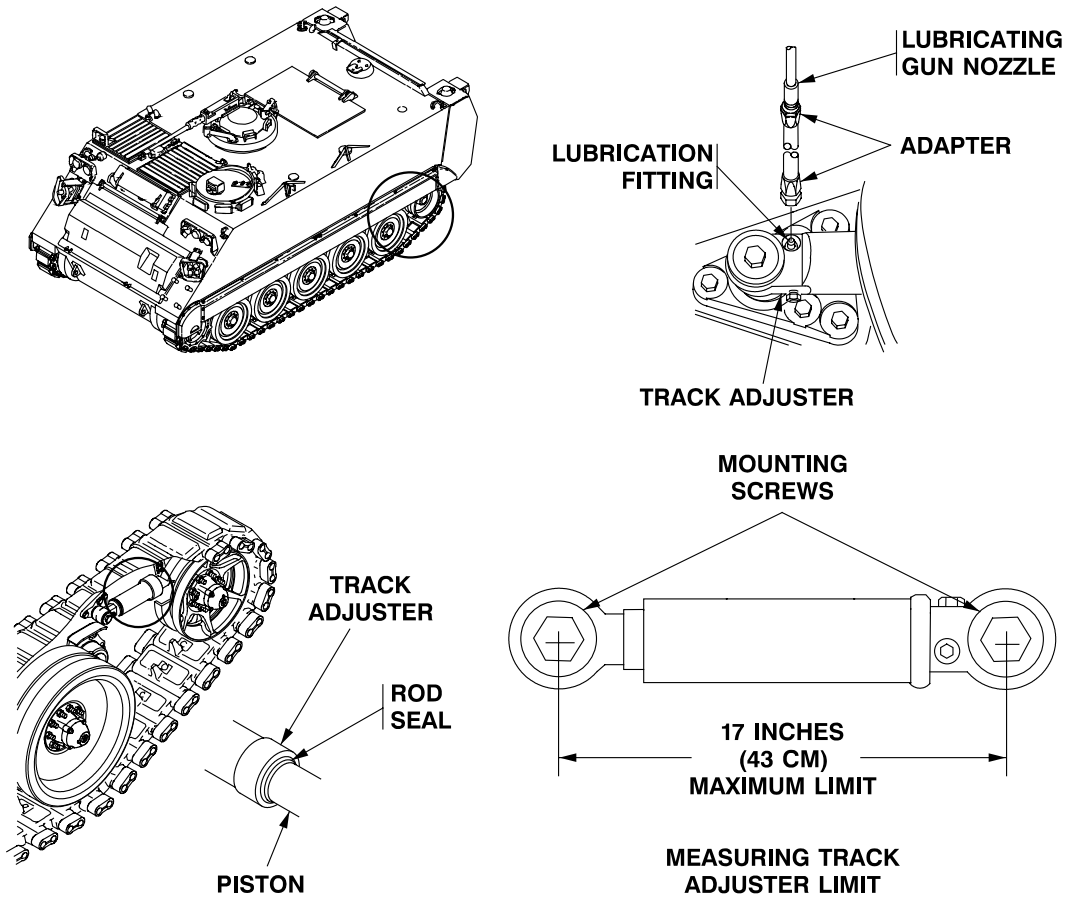

9. To loosen track tension, slowly open bleed valve on track tension adjuster to let grease out. Wipe up excess grease. If track adjuster is in as far as it will go, and track is still too tight, add one track shoe. See task: REMOVE/INSTALL (T150) TRACK SHOE (WP 0093 01) and readjust track tension Steps 5 -9.

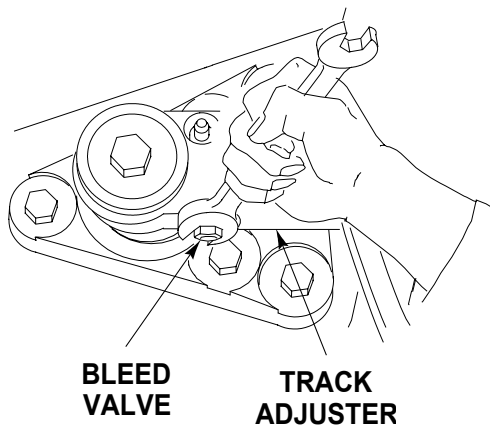

END OF TASK

BREAK/JOIN T130 TRACK

0092 00

THIS WORK PACKAGE COVERS:

- Break Track (page 0092 00-1).
- Join Track (page 0092 00-5).

INITIAL SETUP:

Maintenance Level

Operator

Personnel Required

Driver
Crew

Tools and Special Tools

- Crowbar (WP 0102 00, Table 2, Item 13)
- Drive Pin Punch (WP 0102 00, Table 2, Item 44)
- Grease Gun (WP 0102 00, Table 2, Item 25, Item 25)
- Hammer, 2 lb (WP 0102 00, Table 2, Item 26) or Hammer, 4 lb (WP 0103 00)
- Adjustable Wrench, 1-5/16 inch (WP 0102 00, Table 2, Item 64)
- Socket Handle, 1/2 inch drive (WP 0102 00, Table 2, Item 30)
- Socket, 1 1/16 inch (WP 0102 00, Table 2, Item 49)
- Track Fixture (2) (WP 0102 00, Table 2, Item 23)
- Industrial Goggles (WP 0103 00)

References

- WP 0008 00
- WP 0021 00
- WP 0023 00
- WP 0024 00
- WP 0042 00
- WP 0091 00

Equipment Condition

Engine stopped (WP 0024 00)

BREAK TRACK

1. Unstow crowbar and track fixtures from rear top deck. Remove industrial goggles and hammer from tool bag.

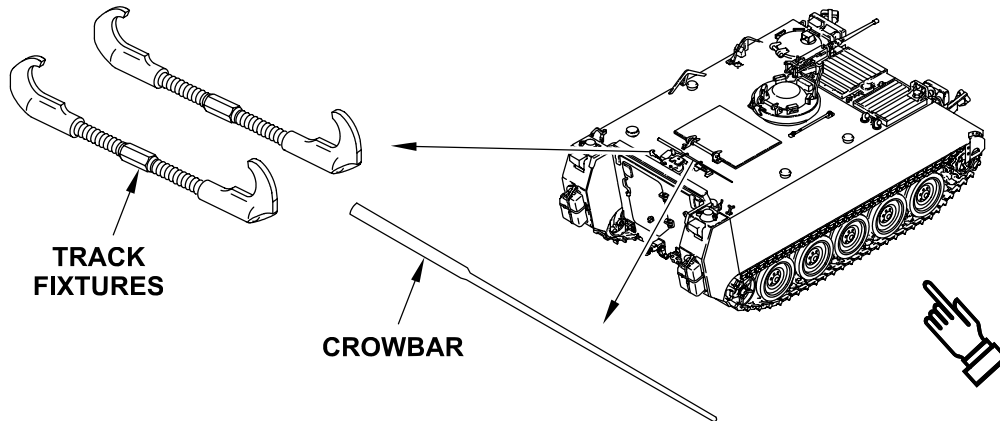

2. Start engine (WP 0021 00).
3. Drive carrier to firm level ground (WP 0023 00).

4. Drive carrier slowly so the track pin to be removed is about halfway between the first road wheel and the sprocket wheel or halfway between the idler wheel and fifth road wheel. Do not use steering wheel or abruptly stop carrier.

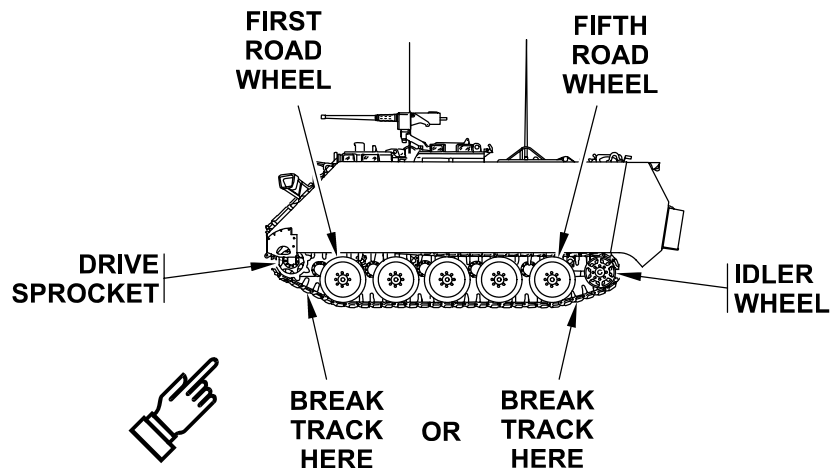

NOTE

Block track with suitable object.

5. Block track on side which is not being broken (WP 0042 00).
6. Stop engine (WP 0024 00).
7. Release track tension all the way on track to be broken (WP 0008 00).

WARNING

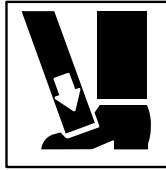

You could be injured if track swings out and hits you. Do not stand in front of track being broken.

8. Install two track fixtures across the pin to be removed. Tighten track fixtures to about a 20 degree angle between the shoes to be disconnected. There should be about 2 inches (5 cm) between the fixtures and the track at the pin. Use adjustable wrench.

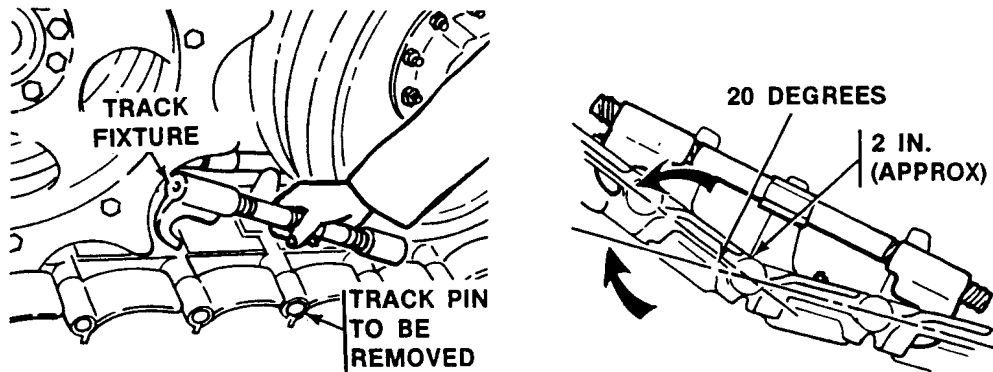

9. Remove track pin nut from track pin to be removed. Use 1/2 inch drive socket handle and 11/16 inch socket.

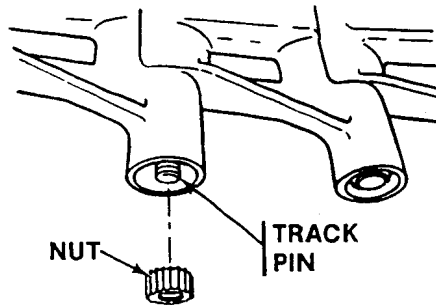

WARNING

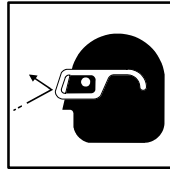

Always wear eye protection when using a hammer. Eye injury may result if metal chips contact eyes.

CAUTION

Track pin threads are easily damaged. Do not force track pin. Tap track pin lightly with hammer.

10. Drive track pin part way out with short end of drive pin punch. Wear industrial goggles and use hammer. Remove drive pin punch.

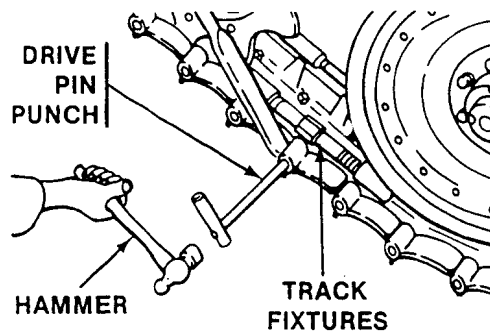

11. Drive track pin all the way out with long end of drive pin punch.

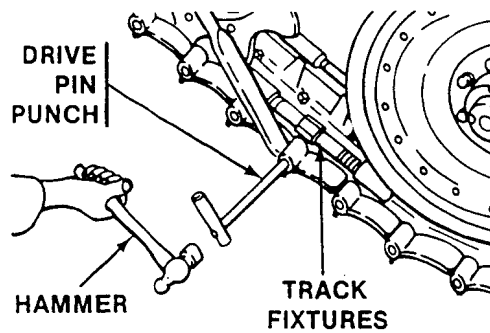

NOTE

Inside track fixture is removed first.

12. If you're planning to add or remove a track shoe, remove two track fixtures. Use adjustable wrench.

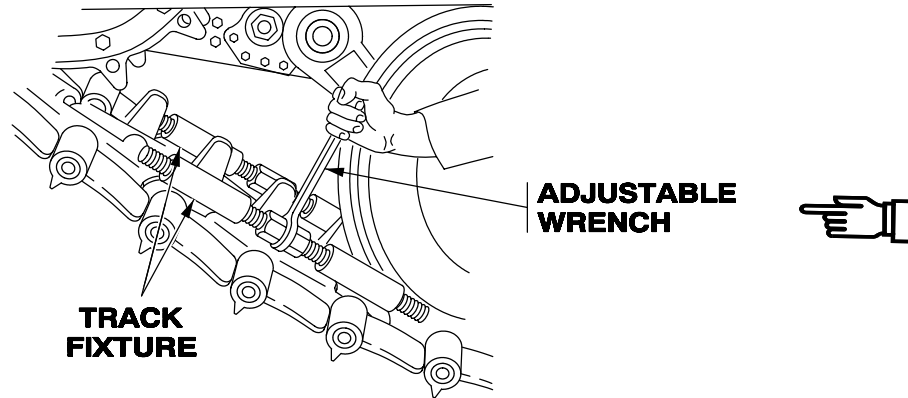

13. Disconnect track. Use crowbar to break track apart.

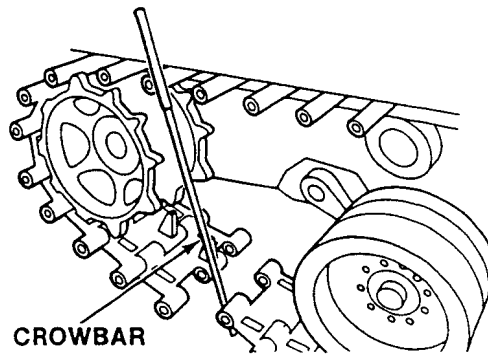

14. If replacing T130 track assembly, see WP 0094 01.
15. Clean up old track assembly and turn into unit maintenance.

JOIN TRACK

WARNING

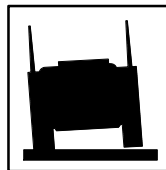

Improper number of track shoes may prevent track from being adjusted correctly, creating a safety hazard.

For carriers with new track, ensure there are 63 track shoes on the left side of carrier and 64 track shoes on the right side of carrier.

For carriers with old track, ensure there are 62 track shoes on the left side of carrier and 63 track shoes on the right side of carrier.

CAUTION

Track pin threads are easily damaged. Do not force track pin. Tap track pin lightly with hammer.

NOTE

If track is difficult to join, use the track fixtures to pull the track together and open the track adjuster relief valve (WP 0091 00) to relieve any track tension from the track adjuster.

NOTE

As track pin moves through track bushing, the track pin will push the drive pin punch out ahead of it.

1. Install two track fixtures across place where track is to be connected. Install track fixture on outside track first. Use adjustable wrench.
2. Move ends of track together with crowbar.

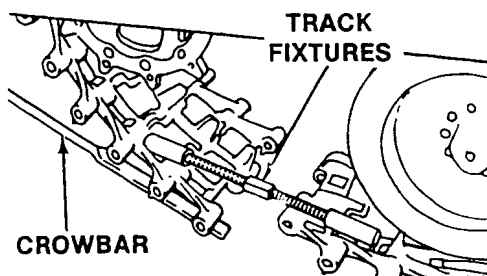
**CAUTION**

Oil or grease will destroy the rubber bushings in track shoes over time. Do not coat track pin with oil or grease.

3. Install a nut flush with one end of the pin.

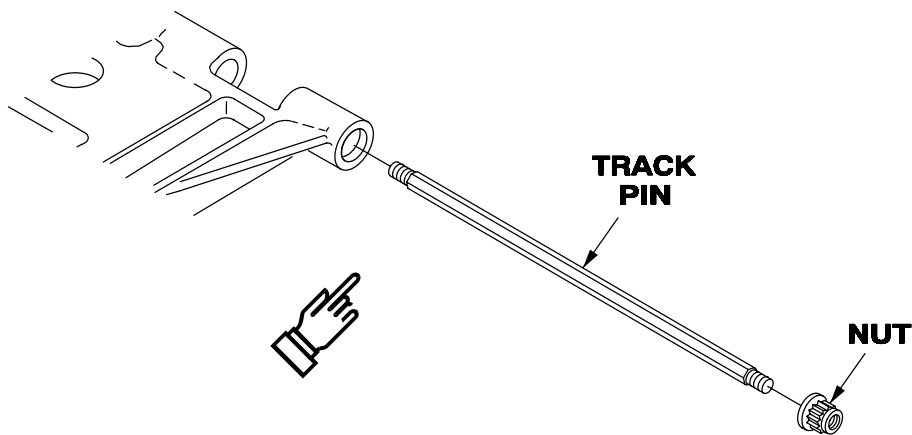

WARNING

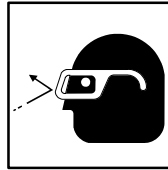

Always wear eye protection when using a hammer. Eye injury may result if metal chips contact eyes.

4. Tighten each track fixture an equal amount to line up track pin holes. Tap long end of drive pin punch through track pin holes to other side of track. Wear industrial goggles and use hammer. Tighten track fixture as needed to obtain 20 degree angle between shoes to be connected. Use adjustable wrench.

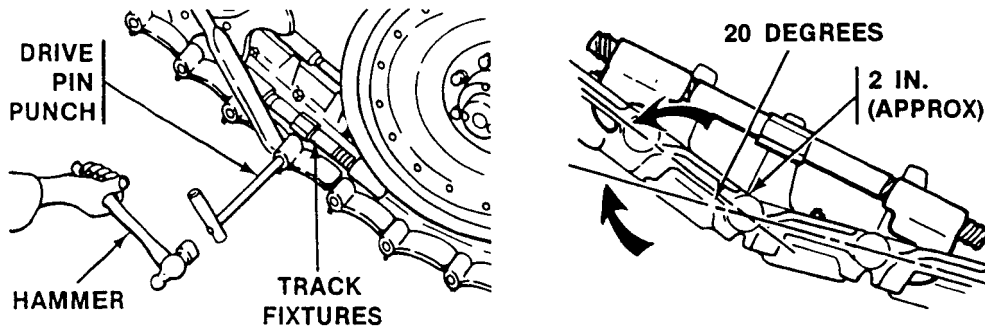

WARNING



Track shoe bushing failure can cause track assembly failure and loss of vehicle control. Soldiers can be killed or injured.

Do not use excessive force that could damage the track shoe bushing while driving in the track pin during assembly.

5. From inside of track, install track pin in track pin hole. As helper aligns track pin holes with crowbar, lightly tap in track pin. Drive track pin all the way through track. Wear industrial goggles and use hammer.

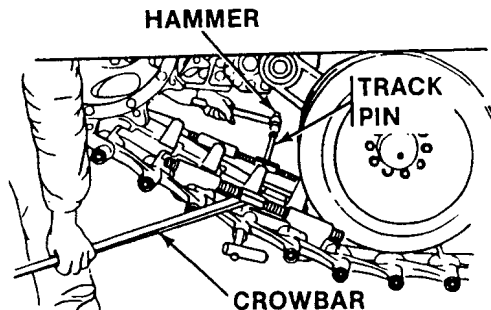

6. Install a nut on the other end of the track pin. Tighten both nuts until two or three threads show between the nuts and the ends of the pin or about 1/8 of an inch. Use 1/2 inch drive socket handle and 11/16 inch socket.

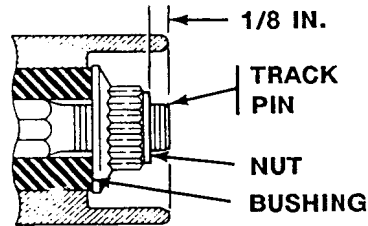

7. Mark nut so unit maintenance can torque it.
8. Remove two track fixtures. Use adjustable wrench.
9. Adjust track tension (WP 0091 00).

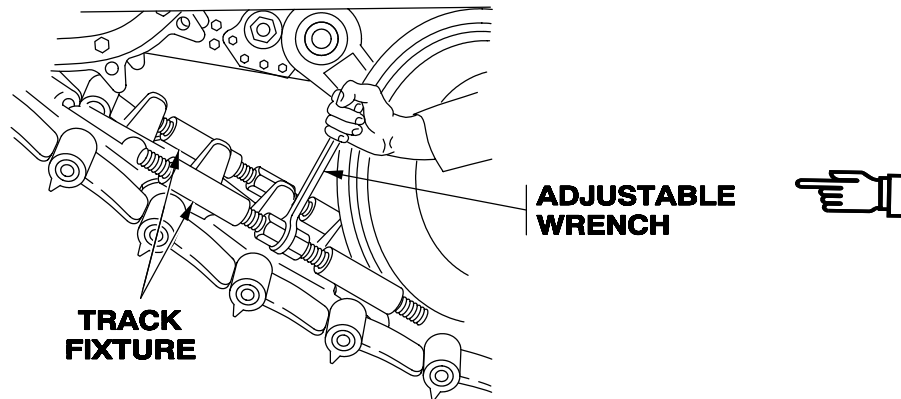

10. Stow crowbar and track fixtures on rear top deck. Stow hammer and industrial goggles in tool bag.

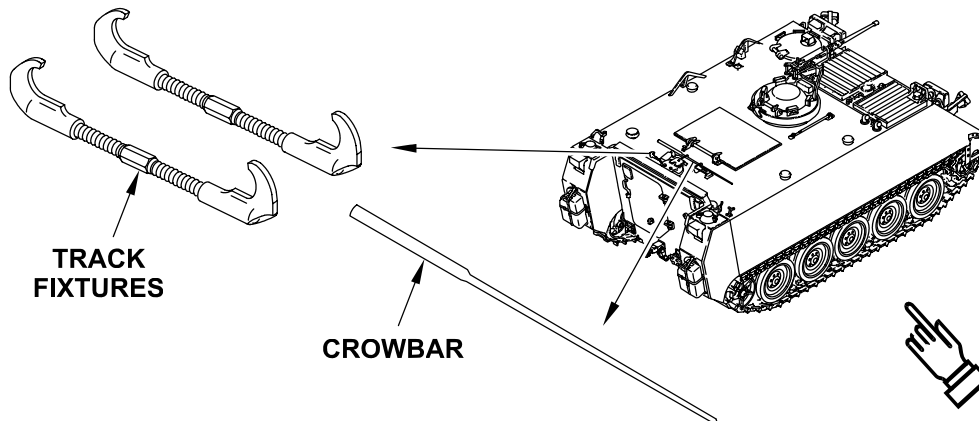

11. Unblock carrier tracks (WP 0042 00).
12. Fill out DA Form 2404 to notify unit maintenance to torque marked track pin nut.

END OF TASK

BREAK/JOIN T150 TRACK

0092 01

THIS WORK PACKAGE COVERS:

Break Track (page 0092 01-1).
Join Track (page 0092 01-6).

INITIAL SETUP:

Maintenance Level

Operator

Personnel Required

Driver
Crew

Tools and Special Tools

- Crowbar (WP 0102 00, Table 2, Item 13)
- End Connector Remover (WP 0102 00, Table 2, Item 44A)
- Grease Gun (WP 0102 00, Table 2, Item 25)
- Hammer, 2 lb (WP 0102 00, Table 2, Item 26) or Hammer, 4 lb (WP 0103 00)
- Adjustable Wrench (WP 0102 00, Table 2, Item 64)
- Handle, Socket Wrench, 3/4 inch drive (WP 0102 00, Table 2, Item 30A)
- Extension Wrench (WP 0102 00, Table 2, Item 19A)
- Socket, 1 1/8 inch, 3/4 inch drive (WP 0102 00, Table 2, Item 49A)
- Track Fixture (2) (WP 0102 00, Table 2, Item 23)
- Tool, Track Pin Alignment (2) (WP 0102 00, Table 2, Item 59A)
- Industrial Goggles (WP 0103 00)

References

- WP 0019 00
- WP 0021 00
- WP 0023 00
- WP 0024 00
- WP 0042 00

Equipment Condition

Engine stopped (WP 0024 00)

BREAK TRACK

1. Unstow crowbar and track fixtures from rear top of deck. Remove industrial goggles and hammer from tool bag.

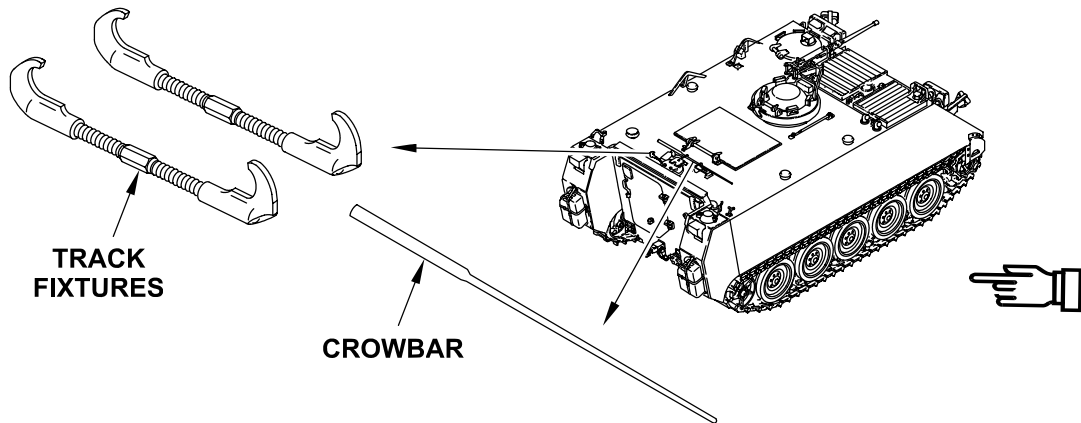

2. Start engine (WP 0021 00).
3. Drive carrier to firm level ground (WP 0023 00).

4. Drive carrier slowly so the track pin to be removed is about halfway between the first road wheel and the sprocket wheel or halfway between the idler wheel and fifth road wheel. Do not use steering wheel or abruptly stop carrier.

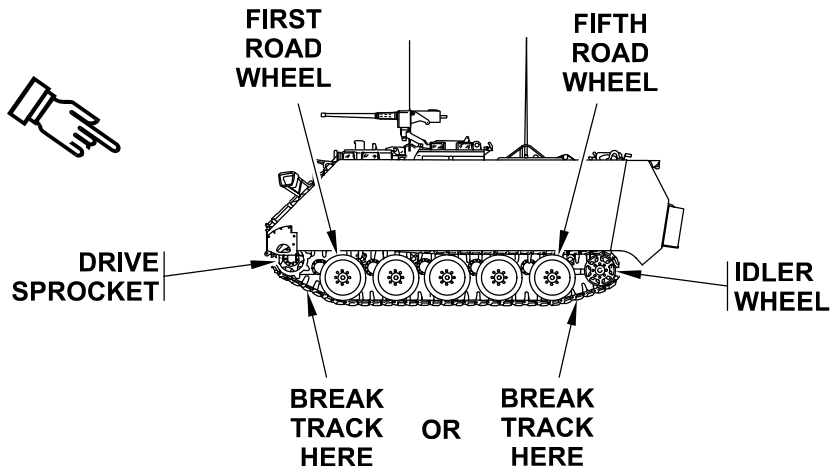

NOTE

Block track with suitable object.

5. Block track on side which is not being broken (WP 0042 00).
6. Stop engine (WP 0024 00).
7. Release track tension all the way on track to be broken (WP 0091 01).

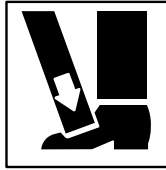
WARNING

You could be injured if track swings out and hits you. Do not stand in front of track being broken.

- Using 3/4 inch socket wrench handle, 1-1/8 inch socket, and wrench extension to get more leverage, remove the end connector bolts to the track shoes that need to be removed to break the track.

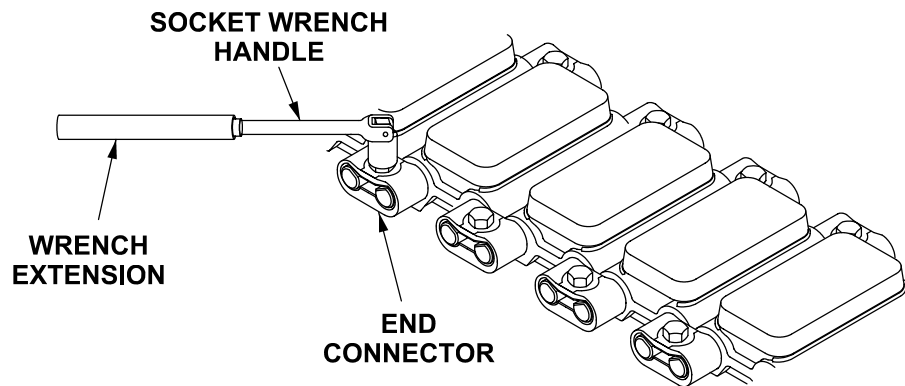

WARNING

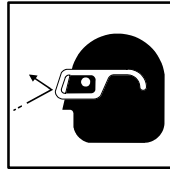

Always wear eye protection when using a hammer. Eye injury may result if metal chips contact eyes.

WARNING

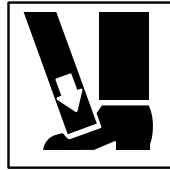

You could be injured if track swings out and hits you. Do not stand in front of track being broken.

CAUTION

Keep personnel clear when removing the end connectors to avoid being hit when it is knocked free from the track shoe pins.

NOTE

Remove outside end connector first, then inside end connector.

9. Install two track fixtures on both sides of the track and tighten to pull track shoes together. Use the track end connector tool and hammer to remove the end connector. Repeat using the track end connector tool to remove the opposite end connector.

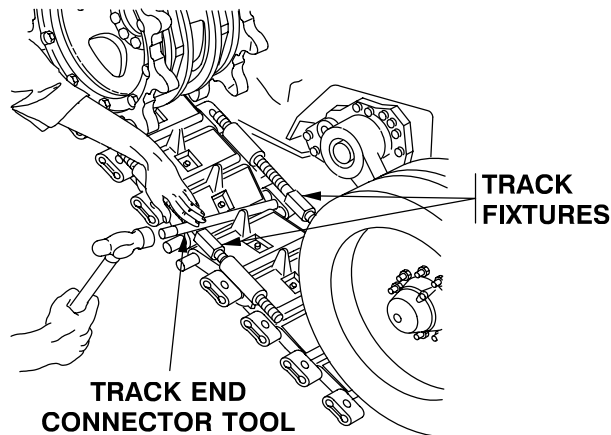

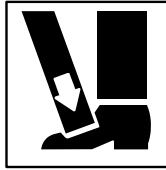
WARNING

You could be injured if track swings out and hits you. Do not stand in front of track being broken.

NOTE

Inside track fixture is removed first.

10. Support track. Use crowbar. Remove inside, then outside track fixtures.

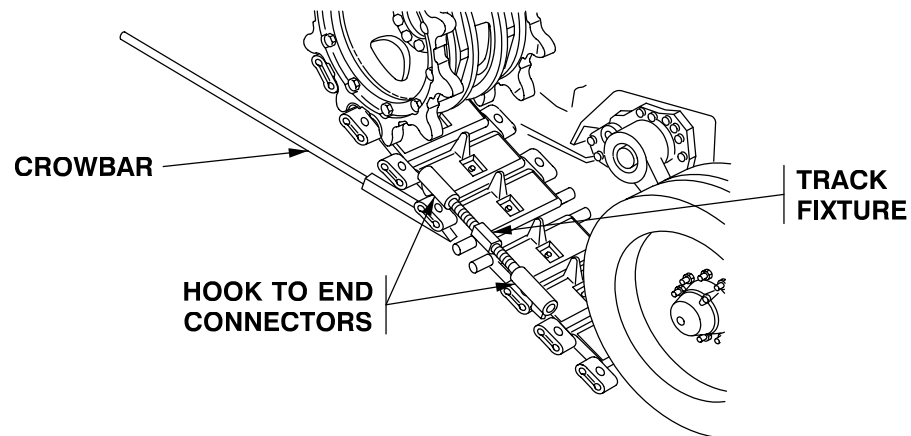

JOIN TRACK

WARNING

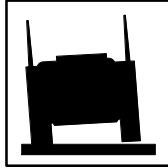

Improper number of track shoes may prevent track from being adjusted correctly, creating a safety hazard.

For carriers with new track, ensure there are 63 track shoes on the left side of carrier and 64 track shoes on the right side of carrier.

For carriers with old track, ensure there are 62 track shoes on the left side of carrier and 63 shoes on the right side of carrier.

NOTE

Center hex nut between hooks on track fixture.

NOTE

Outside track fixture can be positioned from bottom side to aid in installing track alignment tool.

1. Hold track in position and install two track fixtures across place where track is to be connected. Install outside fixture first.

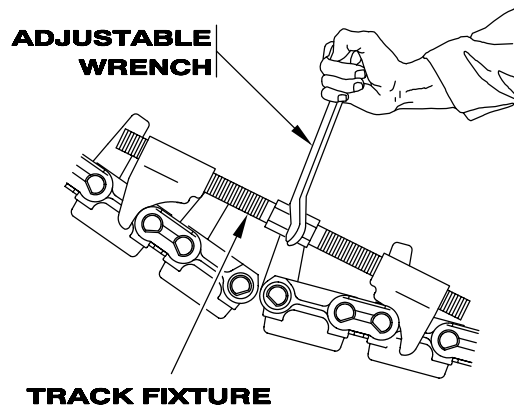
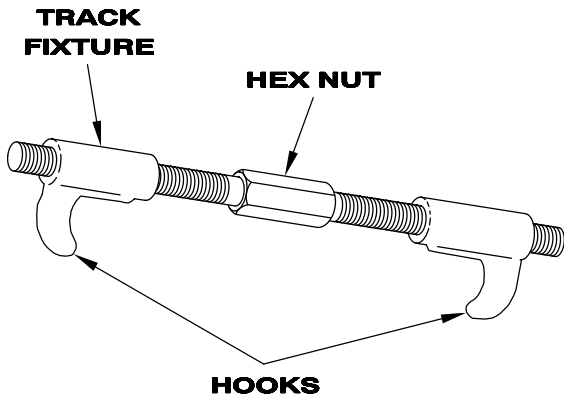

NOTE

Use crowbar to align track as necessary.

2. Tighten two track fixtures evenly until ends of track are close enough to install track alignment tool.

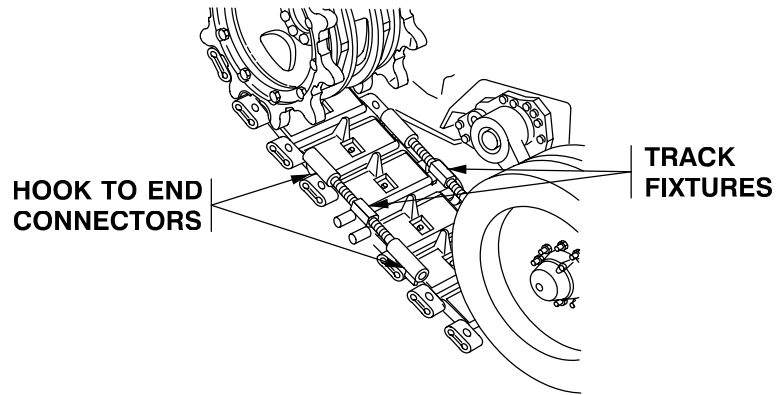

3. Place the track alignment tool over one pin on the outside shoe and rest it on the other pin. Tighten both track fixtures evenly to pull the track assembly together until the track alignment tool fits over and seats fully on both track shoe pins. Install the second track alignment tool on the inside track shoe pins, leave on the inside track fixture.

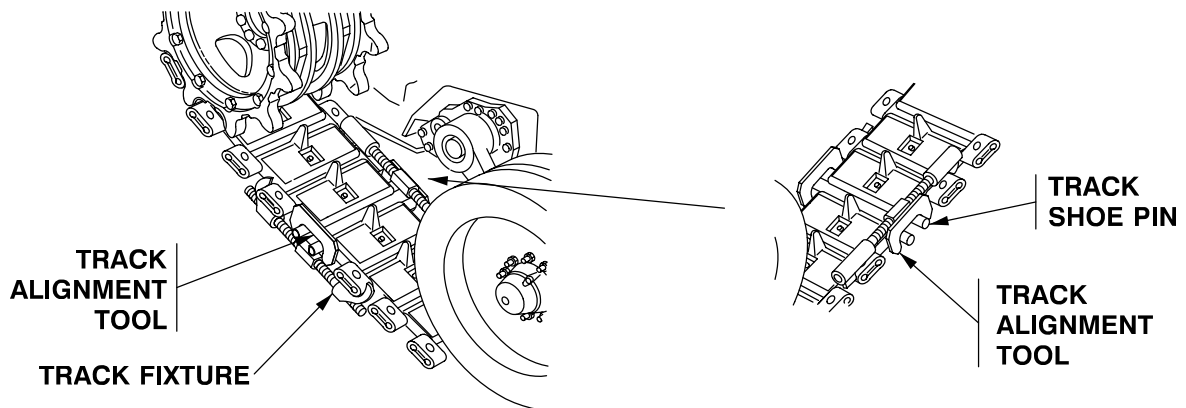

4. Remove the outside track fixture. Both track alignment tools will hold the track together. Leave the track fixture on the inside of the track assembly.

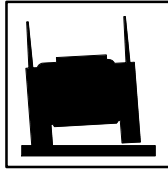
WARNING

Do not use the crowbar on the track shoe pins to get leverage. Any scratches may cause the pin to break and cause the track assembly to fall off the vehicle while operating. This may kill soldiers and damage equipment.

NOTE

Place end connector or similar size block on top of the two track shoes being joined. Use the crowbar under the track fixture connected to the inside track shoes end connectors and press down on the block to get the right angle to install the end connector.

5. Make sure the inside track fixture is tight enough to allow the helper to use the crowbar under it with enough pressure to get a slight degree of angle between the two shoes to allow installing the outside end connector.

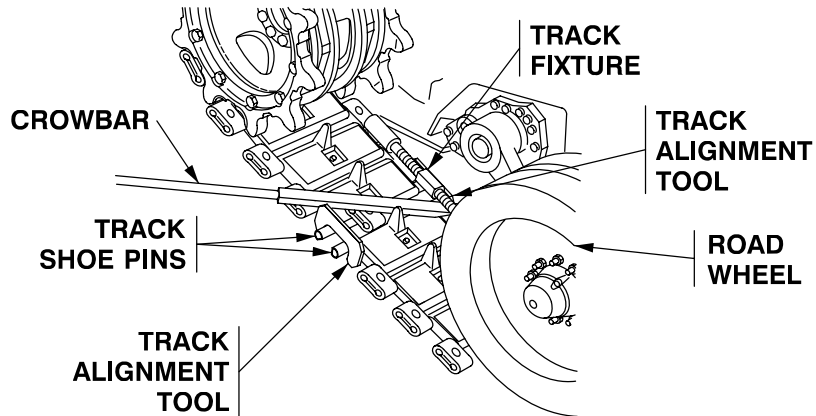

WARNING

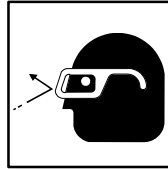

Always wear eye protection when using a hammer. Eye injury may result if metal chips contact eyes.

6. Install the end connector on the outside track shoe pins. Get the angle needed to allow the end connector to fit on the track shoe pins. Tap on the end connector close to the alignment tool. Remove the track alignment tool. Tap the end connector fully onto track shoe pins. Make sure it touches both track shoe bodies.

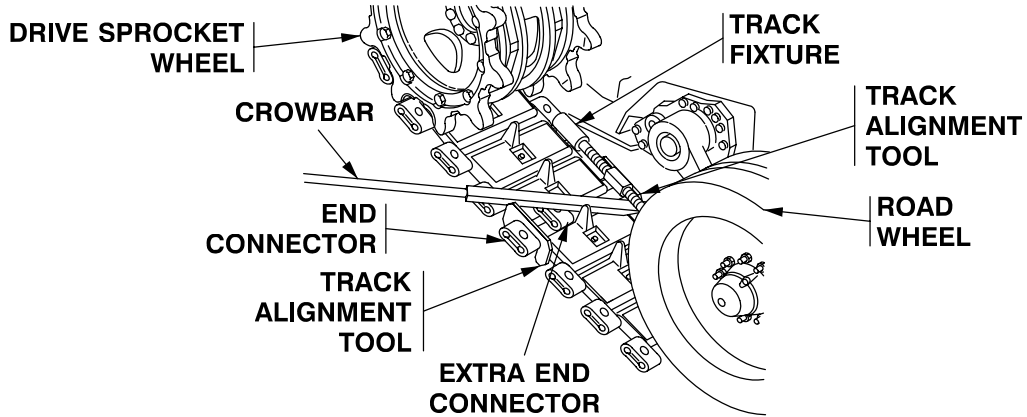

7. Install inside end connector. Only a slight amount or no leverage is needed to install the second connector if the outside end connector is already installed.

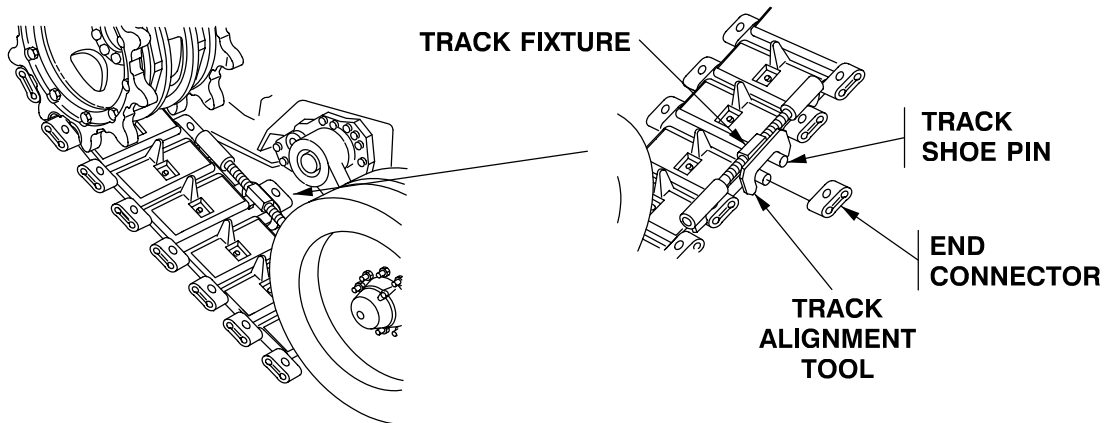

8. Once the end connector is installed halfway on the inside of the track assembly, remove the track fixture and track alignment tool. Finish installing the end connector all the way on the track shoe pins until it touches the track shoe body.

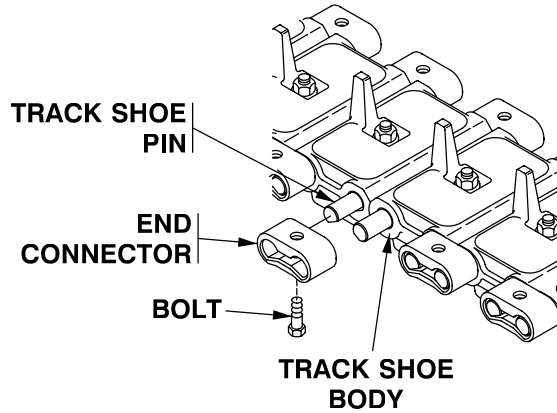

WARNING



Not getting the bolt tight enough may result in death to personnel and damage to equipment if the end connectors fall off during movement of the vehicle. Use the wrench extension over the breaker bar to achieve more leverage when tightening the end connector bolt.

NOTE

Mark the location of the end connectors so unit maintenance can torque them properly. Take the vehicle to unit maintenance as soon as possible to have the end connector bolts torqued to the proper value.

NOTE

Move vehicle far enough to position end connectors that need to be tightened on top.

9. Secure both end connector bolts using the socket wrench handle and wrench extension to get enough torque until you can get it to unit maintenance to torque it properly. Mark the end connectors you have loosened and retightened so unit maintenance can tighten to the right torque value. Fill out DA Form 2404 or DA Form 5988-E to notify unit maintenance.

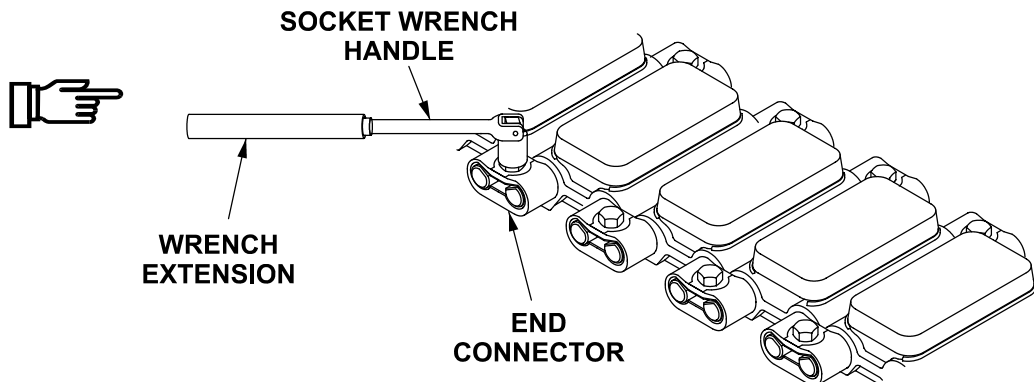

10. Adjust track tension (WP 0091 01).
11. If a new track assembly or any new track shoes were installed, the end connector bolts must be retorqued after 30 to 80 miles of operation. Have unit maintenance retorque each end connector bolt.

END OF TASK

REMOVE/INSTALL T130 TRACK SHOE

0093 00

THIS WORK PACKAGE COVERS:

- Removal (page 0093 00-1).
- Installation (page 0093 00-4).

INITIAL SETUP:

Maintenance Level

Operator

Personnel Required

- Driver
- Helper

Tools and Special Tools

- Crowbar (WP 0102 00, Table 2, Item 13)
- Drive Pin Punch (WP 0102 00, Table 2, Item 44)
- Grease Gun (WP 0102 00, Table 2, Item 25)
- Hammer, 2 lb (WP 0102 00, Table 2, Item 26)
- Open End Wrench, 1-5/16 inch (WP 0102 00, Table 2, Item 64)
- Socket Handle, 1/2 inch drive (WP 0102 00, Table 2, Item 30)
- Socket, 1 1/16 inch (WP 0102 00, Table 2, Item 49)
- Socket, 3/4 inch (WP 0102 00, Table 2, Item 49)
- Track Fixture (2) (WP 0102 00, Table 2, Item 23)
- Industrial Goggles (WP 0103 00)

References

- WP 0092 00
- WP 0091 00

Equipment Condition

- Carrier on level surface
- Engine stopped (WP 0024 00)

REMOVAL

WARNING



Worn or damaged track components can cause track failure and loss of vehicle control. Soldiers can be killed or injured. If track components are not in satisfactory condition, do not operate vehicle.

1. Break track to remove track shoe (WP 0092 00).

- Remove nut from track pin of shoe to be removed. Use 1/2 inch drive socket handle and 11/16 inch socket.

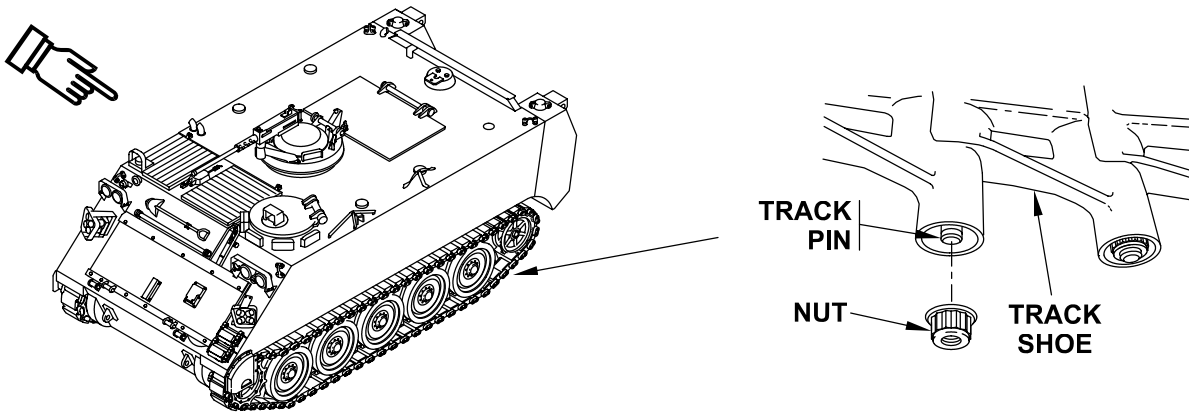

WARNING

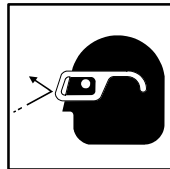

Always wear eye protection when using a hammer. Eye injury may result if metal chips contact eyes.

CAUTION

Track pin threads are easily damaged. Do not force track pin. Tap track pin lightly with hammer.

- Drive track pin part way out with short end of drive pin punch. Wear industrial goggles and use hammer. Remove drive pin punch.

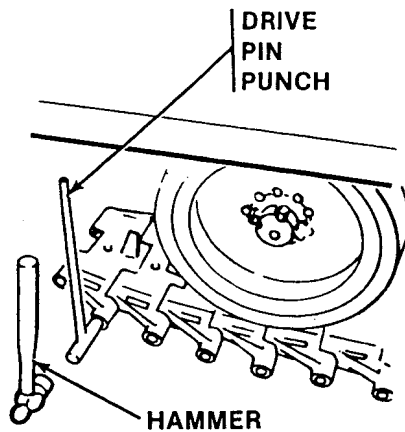

4. Drive track pin all the way out with long end of drive pin punch. Keep short end up and remove drive pin punch.

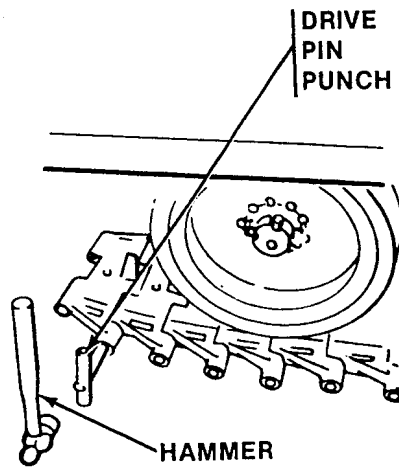

5. Remove track shoe from track. Use crowbar.

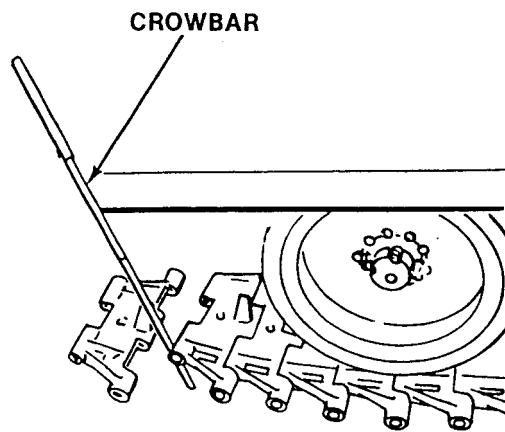

6. If removed shoe is not serviceable, return to unit maintenance. If removed shoe is serviceable, install the pin and nuts in the shoe. Stow shoe on left front of carrier just above the track. Use 1/2 inch drive socket handle and 3/4 inch socket.

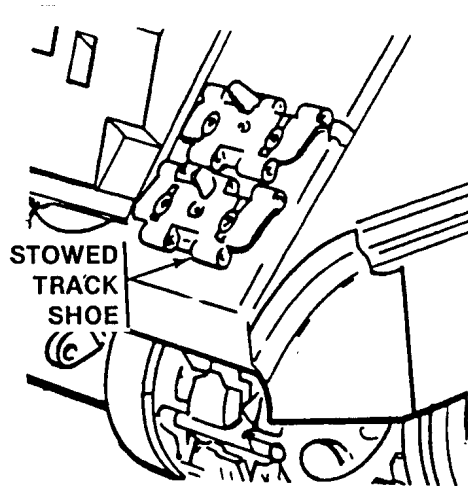

INSTALLATION

1. Unstow a spare track shoe from left front of carrier. Use 1/2 inch drive socket handle and 3/4 inch socket.

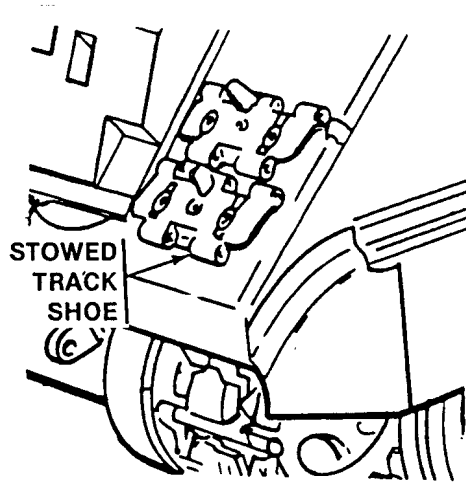

- Remove nut from track pin. Use 1/2 inch drive socket handle and 11/16 inch socket.

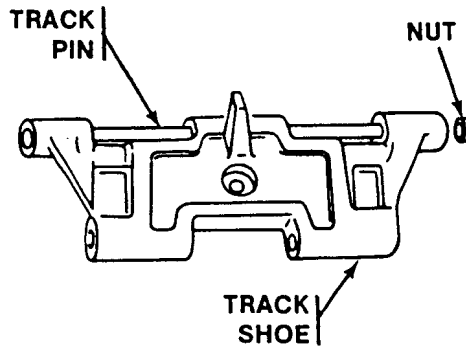

WARNING

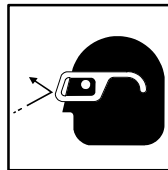

Always wear eye protection when using a hammer. Eye injury may result if metal chips contact eyes.

CAUTION

Track pin threads are easily damaged. Do not force track pin. Tap track pin lightly with hammer.

- Drive track pin part way out with short end of drive pin punch. Wear industrial goggles and use hammer. Remove drive pin punch.

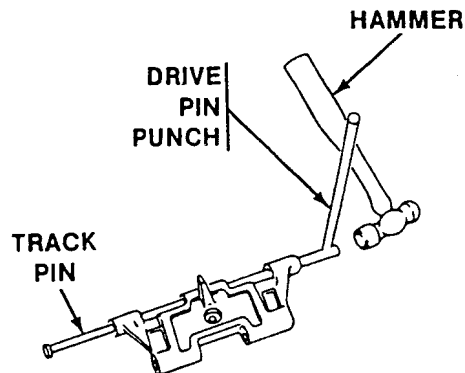

4. Drive track pin all the way out. Wear industrial goggles. Use hammer and long end of drive pin punch.

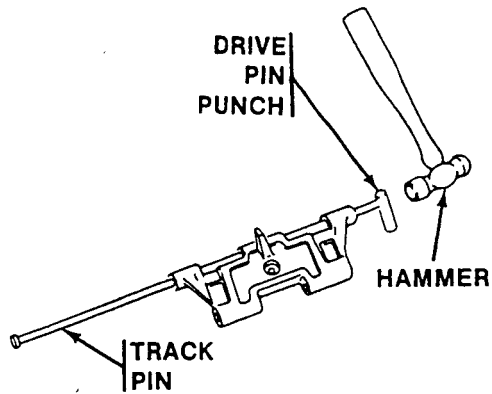

CAUTION

Oil or grease will destroy the rubber bushings in track shoes over time. Do not coat track pin with oil or grease.

5. Install nut flush on track pin. Use 1/2 inch drive socket handle and 11/16 inch socket.
6. Place track shoe in lower part of track. Align track pin holes.
7. Obtain 20 degree angle between track shoes to be connected.

WARNING



Track shoe bushing failure can cause track assembly failure and loss of vehicle control. Soldiers can be killed or injured.

Do not use excessive force that could damage the track shoe bushing while driving in the track pin during assembly.

8. Install track pin in track shoe.

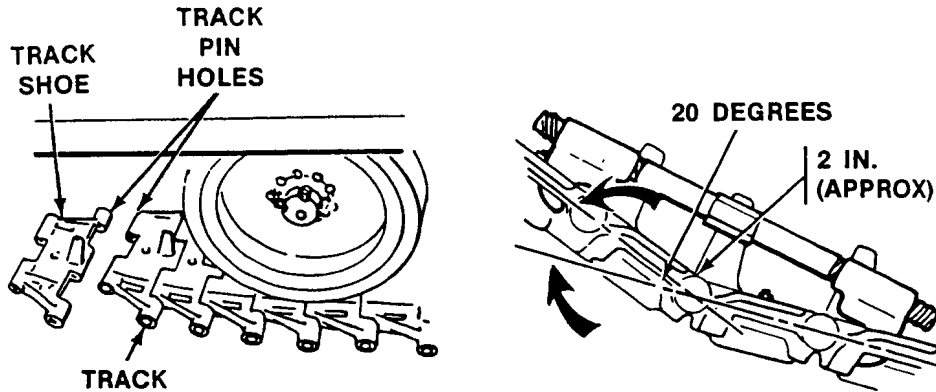

9. Join track (WP 0092 00).
10. Install nut on track pin. Use 1/2 inch drive socket handle and 11/16 inch socket.

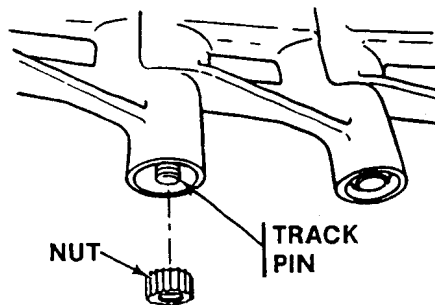

11. Adjust track tension (WP 0091 00).
12. Mark nut so unit maintenance can torque it. Fill out DA Form 2404 to notify unit maintenance to torque marked track pin nuts.

END OF TASK

REMOVE/INSTALL T150 TRACK SHOE

0093 01

THIS WORK PACKAGE COVERS:

Removal (page 0093 01-1).
Installation (page 0093 01-2).

INITIAL SETUP:

Maintenance Level

Operator

Personnel Required

Driver
Crew

Tools and Special Tools

End Connector Remover (WP 0102 00, Table 2, Item 44A)
Hammer, Sledge Hand, 6 lb. (WP 0102 00, Table 2, Item 27) or Hammer, 4 lb (WP 0103 00)
Socket, 3/4 inch drive, 1 1/8 inch opening, 6 pt. (WP 0102 00, Table 2, Item 49A)
Handle, Socket Wrench, 3/4 inch drive (WP 0102 00, Table 2, Item 30A)
Tool, Track Pin Alignment (2) (WP 0102 00, Table 2, Item 59A)
Extension, Wrench Handle (WP 0102 00, Table 2, Item 19A)

References

WP 0092 01

Equipment Condition

Carrier on level surface
Engine stopped (WP 0024 00)

REMOVAL

1. Remove spare track from stowage.
2. Break track (WP 0092 01).
3. Remove track shoe from track.
 - a. Remove two bolts from inside and outside end connectors.
 - b. Remove two end connectors from track shoes.

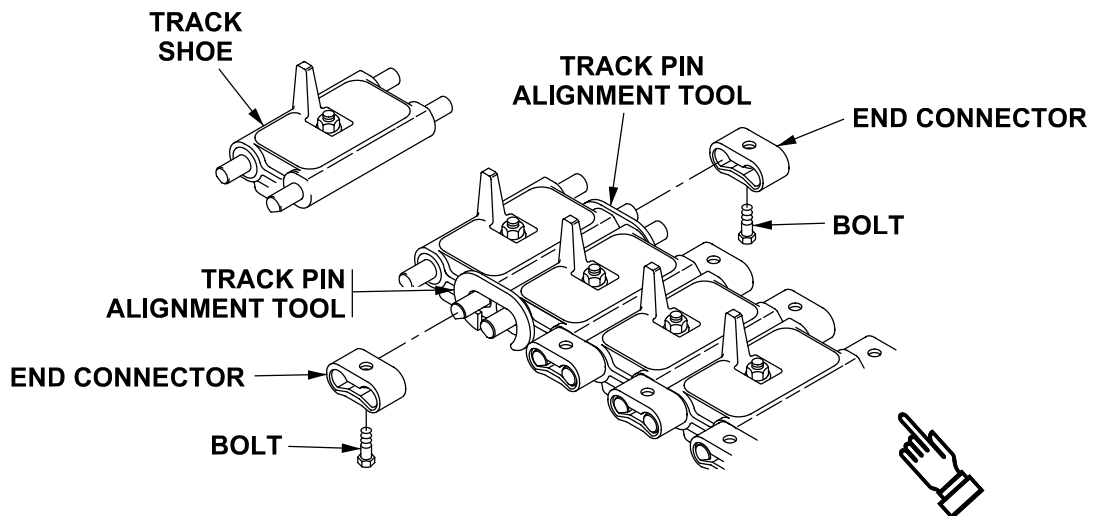

INSTALLATION

WARNING



Loss of track end connector can cause track throw and loss of vehicle control. Soldiers can be killed or injured. Mark end connector bolts. Notify unit maintenance to torque bolts.

NOTE

Position track shoes at slight angle to install end connectors on both shoe pins. Proper tightening of end connector bolts keeps them from coming loose. Have unit maintenance properly torque as soon as possible.

1. Install new track shoe on track.

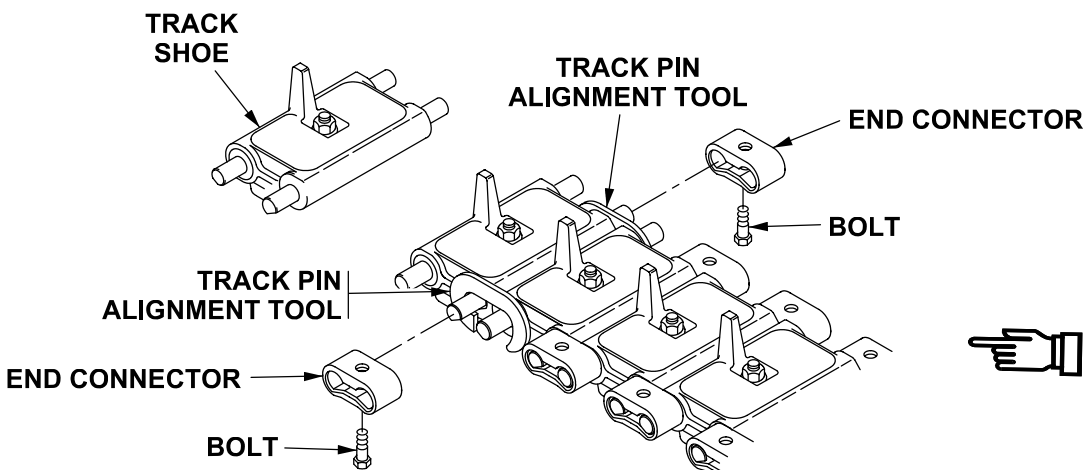

- a. Install two track pin alignment tools over track shoe pins. Install two track end connectors on track shoes. Remove track pin alignment tools before driving end connectors flush with pin ends.
 - b. Drive end connectors flush with pin ends and install bolts on each end connector.
 - c. Tighten bolts using wrench handle extension with socket.
2. Mark track that was replaced so bolts can be torqued later.
 3. Join track WP 0092 01.
 4. Stow spare track shoe
 5. Notify maintenance to torque bolts.
 6. All new, installed track shoes require a check between 30 to 80 miles of operation. END CONNECTOR BOLTS NEED TO BE RETORQUED TO 400-430 LB-FT (543-583 N·M) TORQUE. Notify unit maintenance.

END OF TASK

TRACK SHOE WEAR LIMITS

0094 00

THIS WORK PACKAGE COVERS:

Track shoe wear limits (page 0094 00-1).

INITIAL SETUP:

Maintenance Level

Operator

Tools and Special Tools

Track and Sprocket Gauge (T130) (WP 0102 00, Item 24)
Track Gauge (T150) (WP 0102, Item 24A)

Personnel Required

Soldier

Equipment Condition

Carrier parked on level ground
Engine stopped (WP 0024 00)

INSPECTION OF INSTALLED ITEMS

TRACK SHOE WEAR LIMITS

1. **Grouser height (T130 only).** Measure the height of the top edge of the grouser above the bushing housing. If the shoe has less than 1/8 inch of grouser height left, it must be replaced.

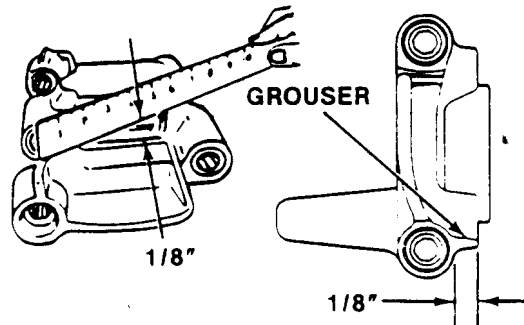

2. **Track shoe pad (Both T130 and T150).** Measure the height of the top of the track shoe pad above the top of the grouser. If this is less than 1/16 inch, the pad is too worn. Have unit maintenance replace the pad.

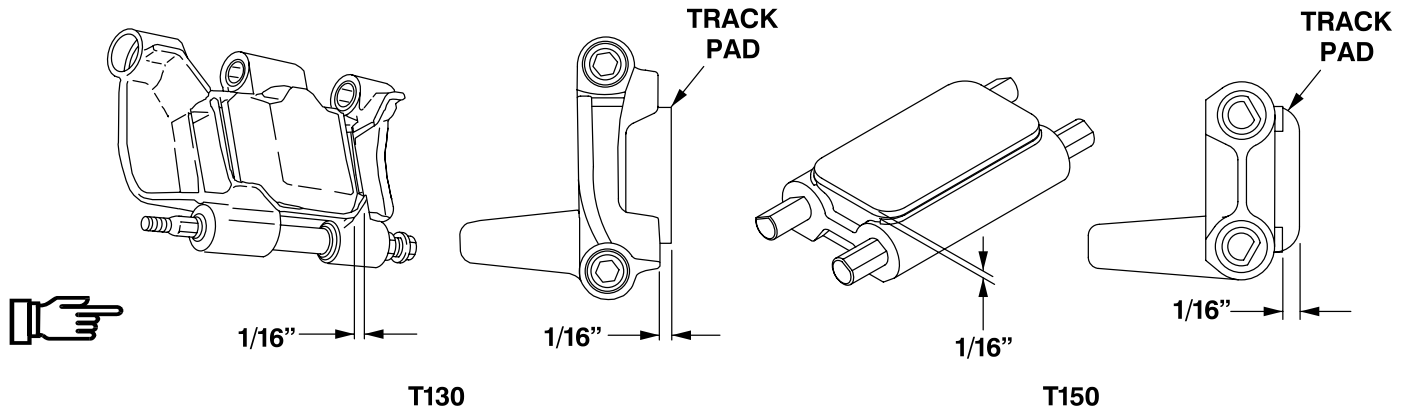

3. **Drive sprocket flange (leading) (T130 only).** On the two bushing end of the shoe, measure the distance from the edge of the sprocket drive hole to the outside of the bushing housing. If the distance is less than 1-15/16 inch, the shoe must be replaced.

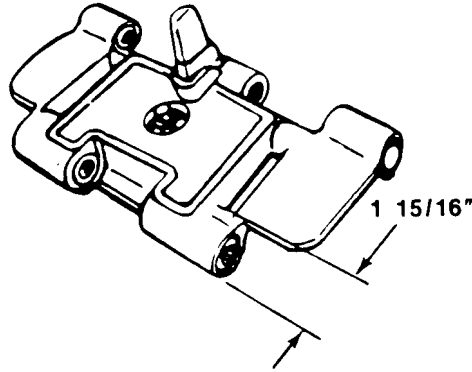

4. **Drive sprocket flange (trailing) (T130 only).** At the three bushing ends of the shoe, measure from the edge of the sprocket drive hole to the nearest outside edge of the shoe. If it's less than 1/2 inch, the shoe must be replaced.

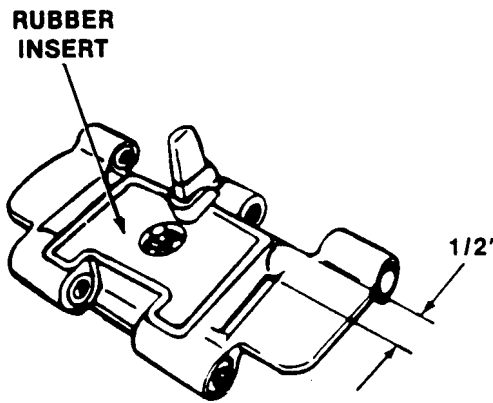

5. **Track shoe forging (T130 only).** Look for cracks in the grousers, pad recess, the ears (track web area outside the grousers and sprocket drive holes), and the sides of the sprocket drive holes. If the cracks are less than 1 inch long in these plates, get the cracks welded. If cracks are one inch or longer, or in any other place, the shoe must be replaced.

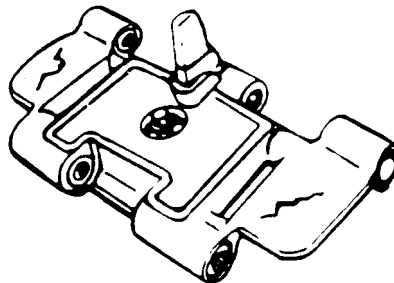

6. **Center guide (T130 and T150).** The center guide has to be $\frac{1}{8}$ inch thick or more, measured $2\frac{3}{4}$ inch from the face of the track. The center guide must be at least $2\frac{3}{4}$ inches long. If the track shoe track gauge fits over the center guide, center guide is worn. Report to unit maintenance to replace the track shoe. Use track gauge as shown for T150. If track gauge touches shoe, replace shoe.

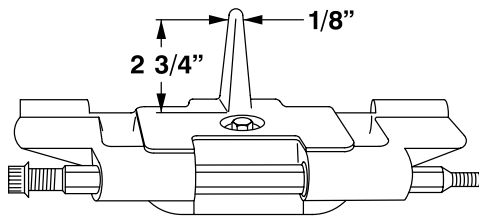

T130

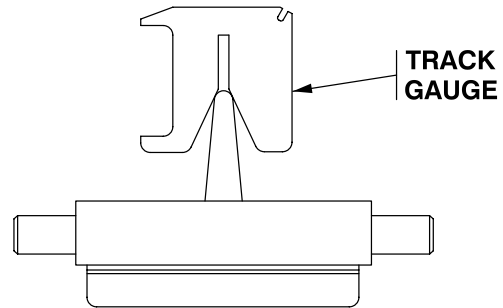

T150

7. **Rubber inserts (T130 only).** Look at the rubber inserts that bear on the road wheels. If there is $\frac{3}{8}$ inch or more separation between the rubber and metal all the way around, the shoe must be replaced. If the insert shows chunking $\frac{1}{2}$ inch or more deep on 10 percent or more of its surface, the shoe must be replaced.

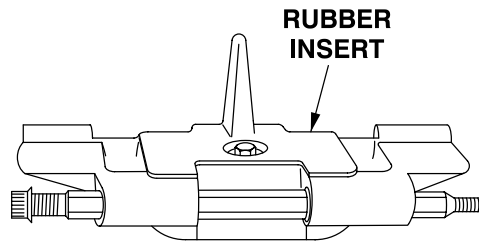

T130

8. **Bushing wear (T130 and T150).** With the track on the carrier and under normal tension, insert pins of track and sprocket gauge into track shoes. (T130) If pins of track gauge enter both track shoes freely, track bushings are OK; if pins do not enter both track shoes freely, bushings are worn. Report any worn bushings to unit maintenance. (T150) If track shoe gauge enters both end connector pins, bushings are worn. Notify unit maintenance to replace track shoe.

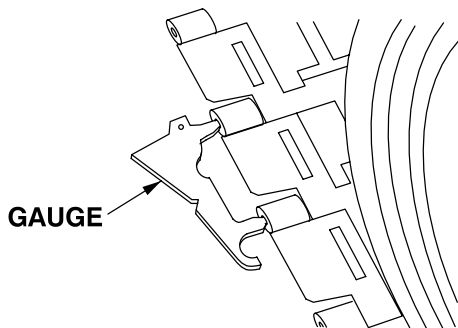

T130

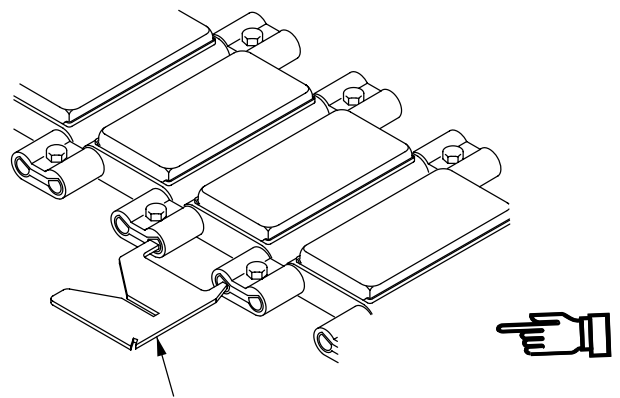

T150

9. **Dead shoes (T130 and T150).** Look for shoes with one end that sticks up above the same side of the next shoes on upper side of track. This is caused by the rubber bushing rotating in the shoe. Record fault on DA Form 2404 and report to unit maintenance. If carrier has extra shoes stowed on front of carrier, replace dead shoes. See task: REMOVE/INSTALL (T130) TRACK SHOE (WP 0093 00) or REMOVE/INSTALL (T150) TRACK SHOE (WP0093 01).

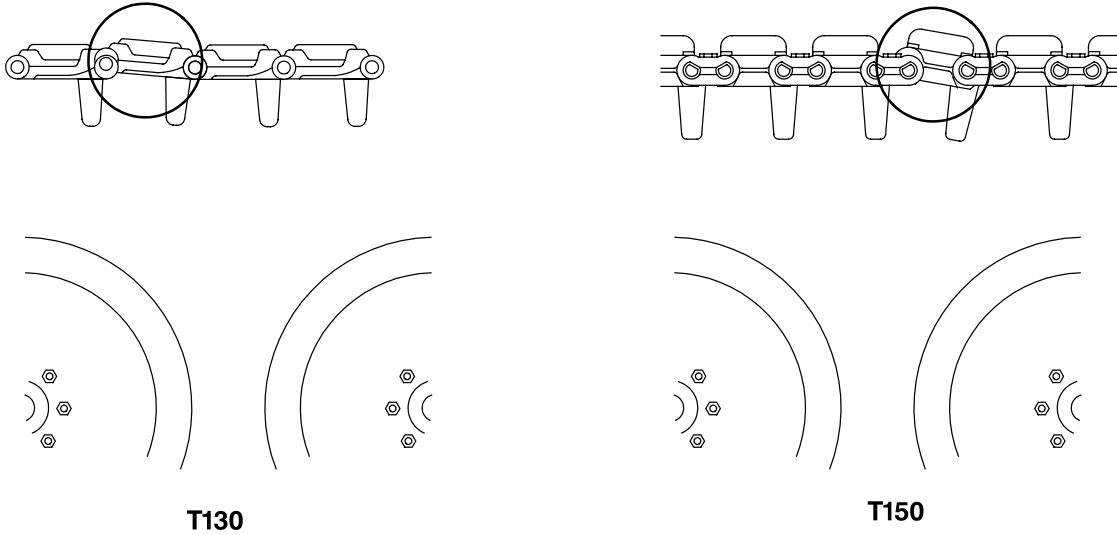

10. **End Connectors (T150 only).** Visually look at the outside edge thickness of the end connectors. If any end connector appears to be worn where the sprocket teeth make contact more than the rest of the end connectors, the end connector must be removed to measure it with the track gauge. The inside portion is generally where it will wear out and can only be checked when it is removed from the track shoe. If you remove the end connector to measure it and reinstall it, make sure you have unit maintenance torque it properly before operating the carrier for any length of time or going on any missions. Measure the outside edge thickness of end connector. If the track gauge fits over the end connector edge, end connector is worn. Have unit maintenance replace end connector.

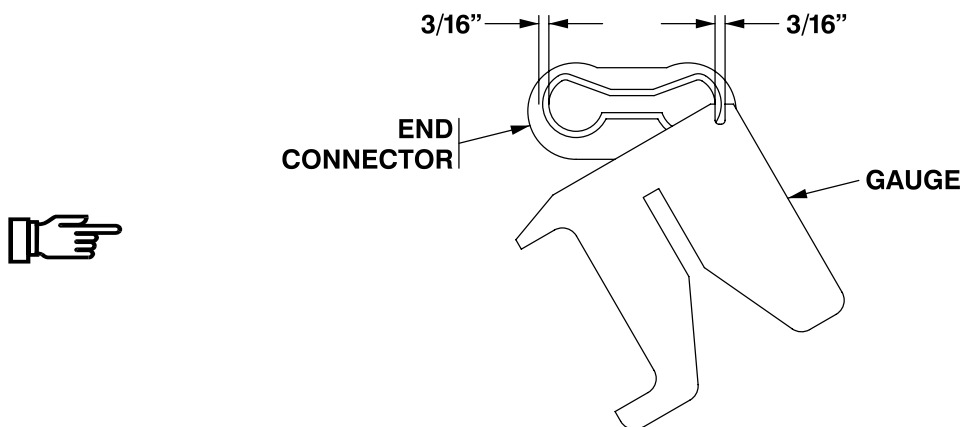

END OF TASK

ASSEMBLE T130 TRACK SHOE SECTIONS OFF VEHICLE

0094 01

THIS WORK PACKAGE COVERS:

Assembly (page 0094 01-1).

INITIAL SETUP:

Maintenance Level

Operator

Personnel Required

Driver

Helper (H)

Tools and Special Tools

Crowbar (WP 0102 00, Table 2, Item 13)

Drive Pin Punch (WP 0102 00, Table 2, Item 44)

Grease Gun (WP 0102 00, Table 2, Item 25)

Hammer, 2 lb (WP 0102 00, Table 2, Item 26)

Industrial Goggles (WP 0103 00)

Adjustable Wrench, 1-5/16 inch (WP 0102 00, Table 2, Item 64)

Socket Wrench, 11/16 inch (WP 0102 00, Table 2, Item 49)

Track Fixture (WP 0102 00, Table 2, Item 23)

Wrench Handle (WP 0102 00, Table 2, Item 30)

Equipment Condition

Track on level surface

ASSEMBLY

NOTE

Track shoe sections may come in 7 or 8 shoes per section. Make sure to count the number of shoes during assembly. For all M113A3 FOV there are 63 track shoes required for the left side and 64 track shoes required for the right side. Inspect each track shoe to see if anything is wrong before it is assembled.

1. Match two sections of track. Have helper assist.

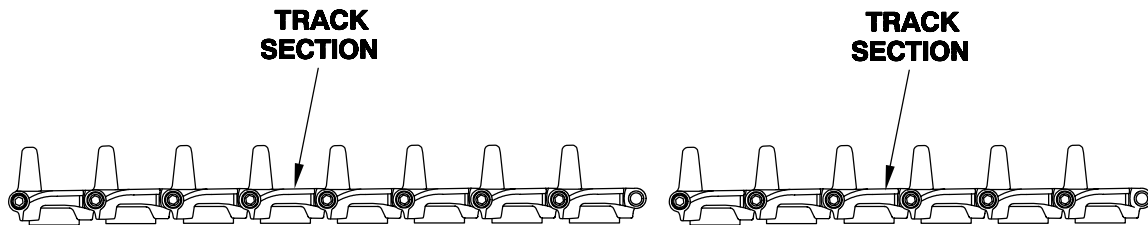

2. Remove nut from track pin. Use 1/2 inch drive socket handle and 11/16 inch socket.

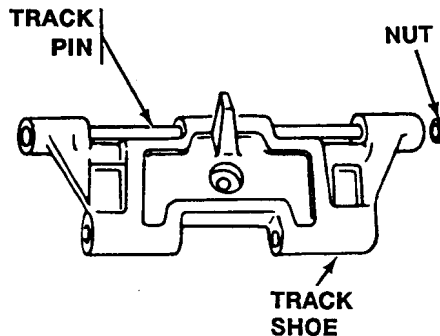

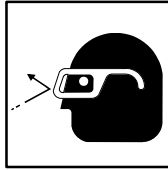
WARNING

Always wear eye protection when using a hammer. Eye injury may result if metal chips contact eyes.

CAUTION

Track pin threads are easily damaged. Do not force track pin. Tap track pin lightly with hammer.

3. Drive track pin part way out with short end of drive pin punch. Use hammer. Remove drive pin punch.

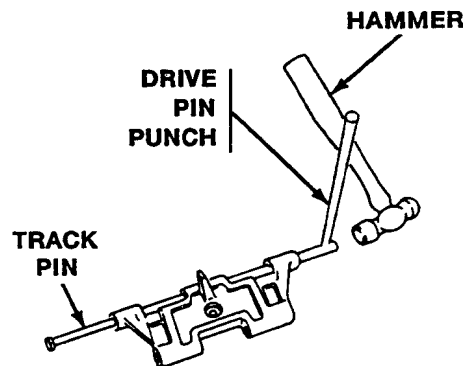

4. Drive track pin all the way out. Use hammer and long end of drive pin punch.

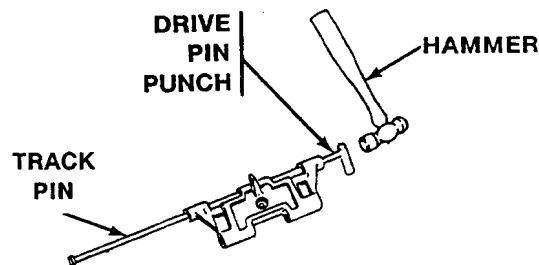

5. Insert drive pin punch into track shoes to keep sections together.

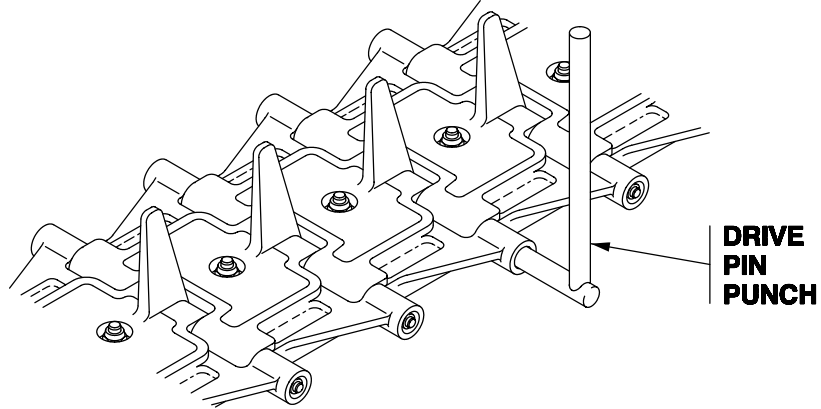

6. Insert crowbar in first track shoe slot. Lift or tilt track to obtain the 20 degrees or approximately 5 inch (13 cm) lift as shown below to get the right angle for installing the track pin through both track shoes. Adjust crow bar angle to help allow the track pin to be driven smoothly into place.

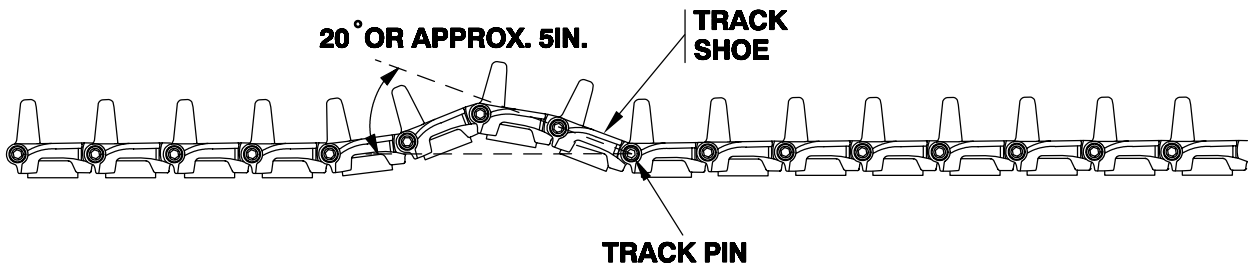

WARNING

Track shoe bushing failure can cause track assembly failure and loss of vehicle control. Soldiers can be killed or injured.

Do not use excessive force that could damage the track shoe bushing while driving in the track pin during assembly.

WARNING

Track shoe bushing failure due to improper angle of track during pin assembly can cause track assembly failure and loss of vehicle control. Soldiers can be killed or injured.

Make sure track is assembled with the right amount of angle or lift as shown below. Properly assembled track will lay flat. Incorrectly assembled track will bulge upward.

CAUTION

Oil or grease will damage the track shoe bushing over time. Do not use oil or grease on track pin during assembly. Track pins have a coating to protect them from rusting that does not need to be removed.

7. Insert track pin into track shoe. Use 2 lb hammer. Adjust crowbar angle to obtain 20 degrees or approximately 5-inch angle as shown.
8. Install and tighten nut until one full thread shows on track nut. Use 1/2 inch drive socket wrench handle and 11/16 inch socket.
9. Scribe a mark with a screwdriver above the nut on the metal surface of shoe, for torquing by unit maintenance. Contact unit maintenance.

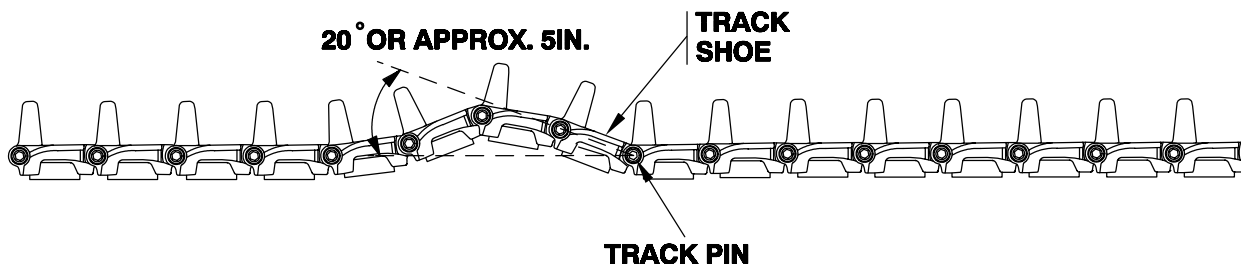

10. Repeat Steps 1 - 9 until you have 63 or 64 track shoes in one assembly.

END OF TASK

CHECK CARRIER BATTERIES

0095 00

THIS WORK PACKAGE COVERS:

Operational Check (page 0095 00-1).

INITIAL SETUP:

Maintenance Level

Operator

References

TM 9-6140-200-14
 TM 11-7010-256-12&P

Tools and Special Tools

Flashlight (WP 0104 00, Item 9)

Equipment Condition

Engine stopped (WP 0024 00)
 M1068A3 only — CHS Equipment removed
 (TM 11-7010-256-12&P)
 M1068A3 only — All external power disconnected
 (TM 11-7010-256-12&P)

Materials/Parts

Grease (WP 0104 00, Item 10)

Personnel Required

Driver

OPERATIONAL CHECK

NOTE

Do Step 1 for M113A3 only.

1. Slide spall liners to the front or rear to access batteries. See task: POSITIONING SPALL LINERS FOR ACCESS TO EQUIPMENT (WP 0041 00).

WARNING

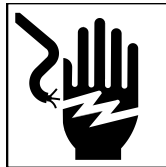

Battery posts and cables touched by metal objects can short circuit and burn you or injure you. Use caution when you work with tools or other metal objects. Do not wear jewelry when you work on electrical system.

WARNING



Gas from batteries can explode and injure you. Do not allow sparks near batteries. Battery acid can blind or burn you. Do not get acid on your skin or eyes.

NOTE**Do Step 2 for M113A3 and M1059A3.**

2. Unlatch six latches and remove two covers from battery boxes.

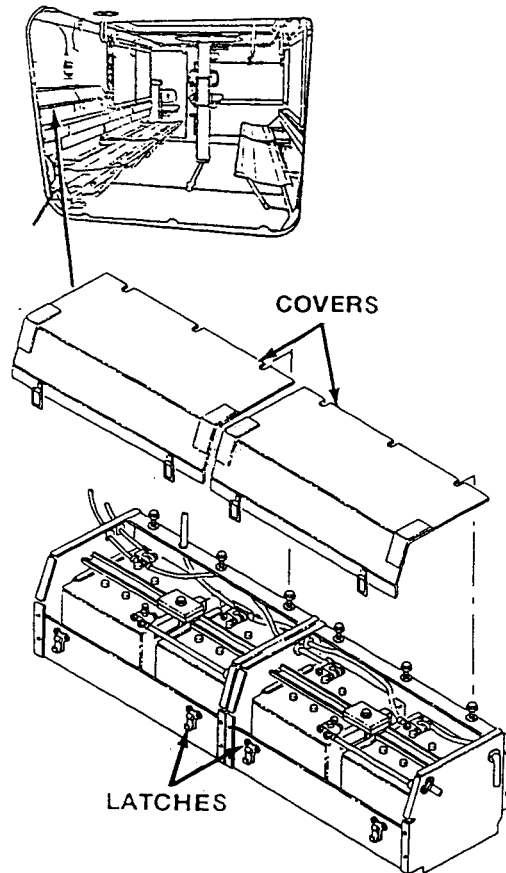

NOTE

Do Step 3 for M58 only.

3. Release two latches and lift battery box cover. (Battery box is located on left sponson.)

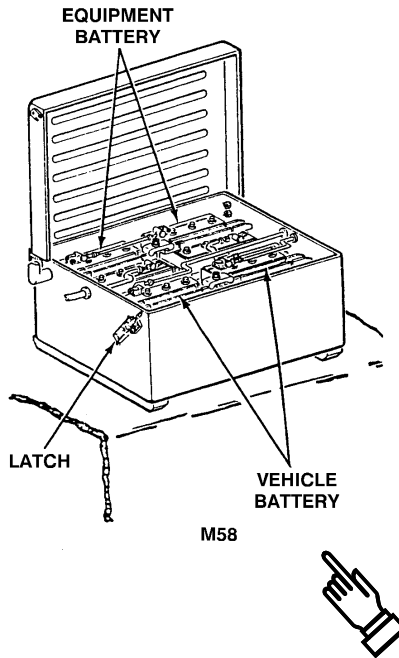

NOTE

Do Step 4 and Step 5 for M577A3 only.

4. Remove strap from table top and battery box. Pull rod downward from securing clip. Raise table top and use rod to secure table top up while performing any maintenance or inspection of batteries.
5. Remove two wing nuts that secure battery box cover to battery box. Remove battery box cover.

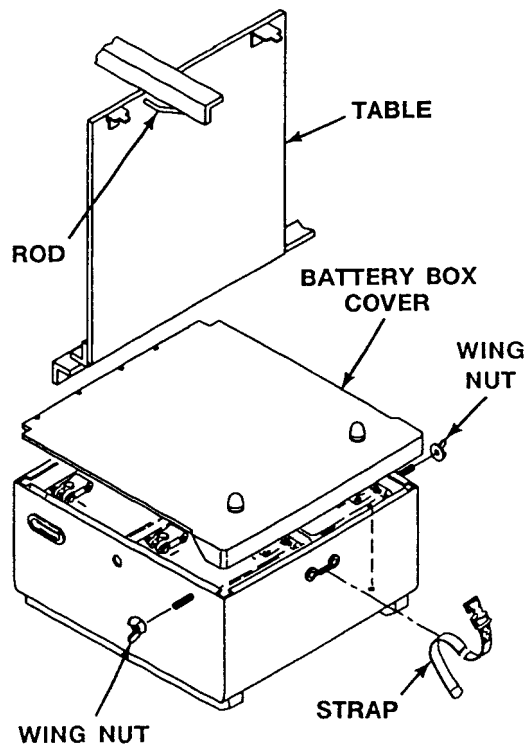
**NOTE**

Do Steps 6 - 8 for M1068A3 only.

6. Loosen two nuts and swivel bolt off extension base bracket.
7. Push lever towards the right side wall and put lever in latch position. Raise extension base and secure with strap. The guide has a position for the lever in the locked position and in the released position.

8. Open two latches that secure battery box cover to battery box. Remove battery box cover.

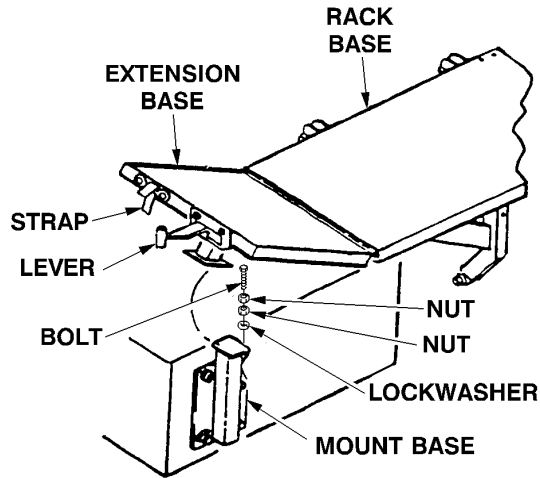

NOTE

Do Step 9 for batteries on left side M1064A3 only.

9. Lower left crew seat back rest and turn handle. Pull drawer out.

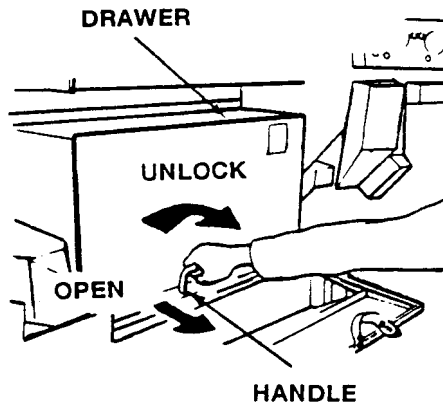

NOTE

Do Step 10 for batteries on right side M1064A3 only.

10. Release catches on each side of battery box/seat support. Remove battery box cover/seat.

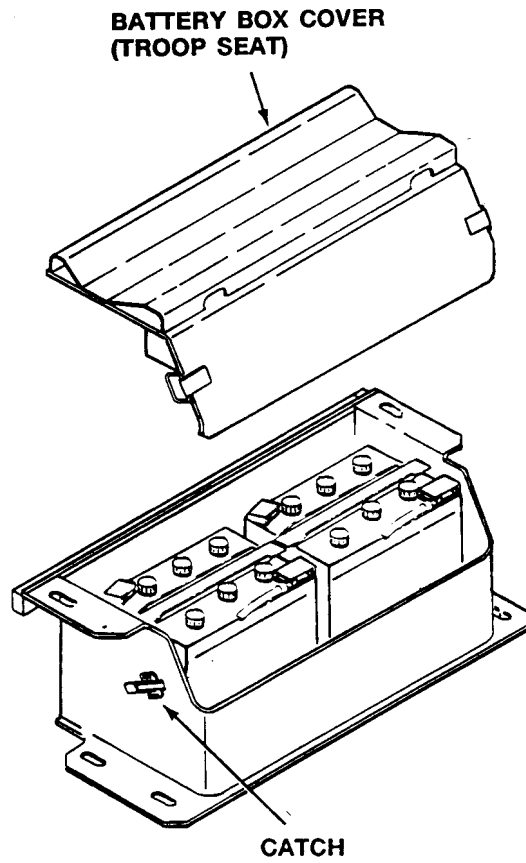

11. Check battery retainers and clamps with both hands and try to move them. If batteries move or seem loose, report it to unit maintenance.

12. Check battery connections. Try to twist each clamp with thumb and first two fingers. Check to see if cables are securely connected to clamp. If any clamp or connection is loose, report it to unit maintenance.

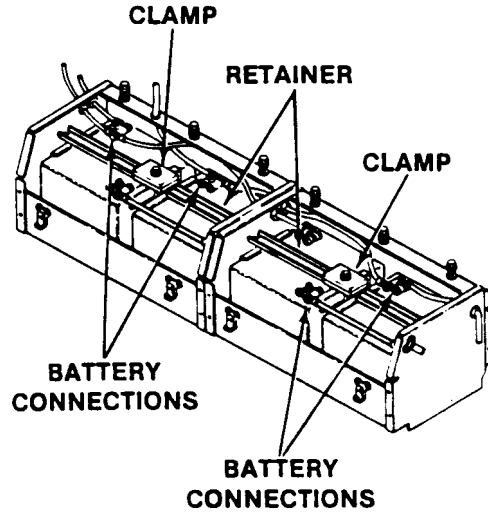

NOTE

Check the water level more frequently in hot weather.

13. Remove vent plugs from batteries and check battery electrolyte level. Use a flashlight. Look down into each battery cell. The electrolyte level should be covering the plates and to the lower edge of the vent. If battery cells are low or dry, add distilled water. Check that vent holes are clear in caps (plugs) before installation. Install vent plugs on battery cells.
14. Clean battery. Wipe off battery casing and surrounding metal parts. Use clean dry wiping rag. Check terminals, clamps, cables and retainers for corrosion.
15. Coat terminals with a small amount of grease (GAA).

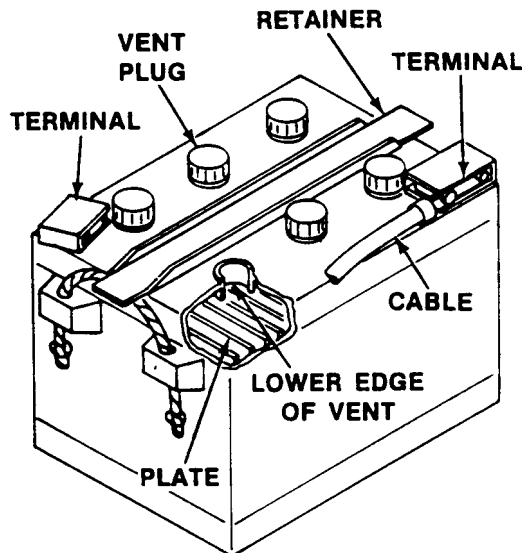

NOTE

Do Step 16 for batteries on right side M1064A3 only.

16. Position battery box cover/seat on battery box support. Latch catches to secure battery box cover/seat.

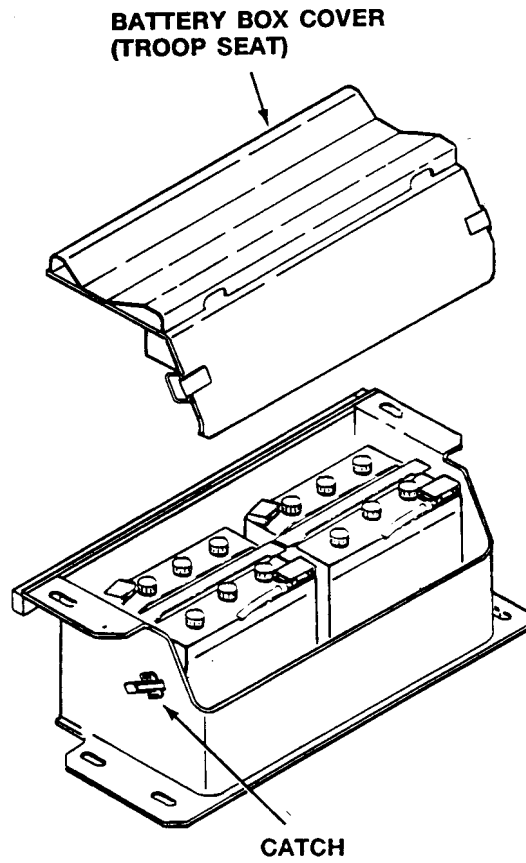

NOTE

Do Step 17 for batteries on left side M1064A3 only.

17. Install drawer on battery box and turn handle. Raise left crew seat back rest.

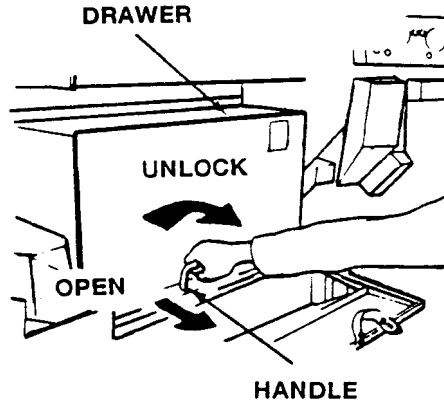
**NOTE**

Do Steps 18 - 20 for M1068A3 only.

18. Slide battery box cover onto battery box. Secure cover with two catches.
19. Hold extension base and remove strap. Secure strap back in place. Lower extension base and push lever towards the wall to release latch, then leave lever in latch locked position to keep end of extension base secure.
20. Swivel bolt with washer and two nuts on top of extension base bracket. Tighten first nut to secure bracket to support. Then tighten second nut securely against first nut.

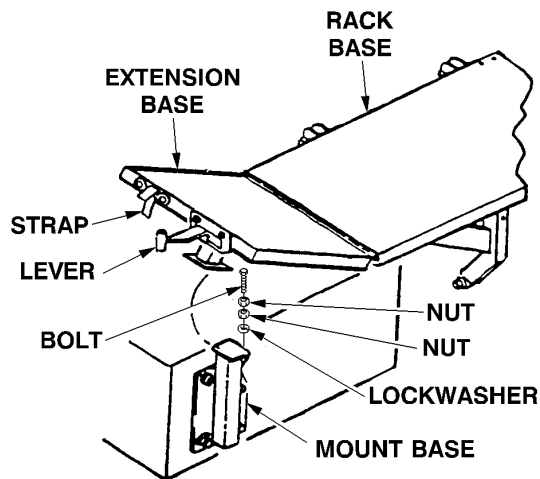

NOTE

Do Step 21 and Step 22 for M577A3 only.

21. Slide battery box cover onto battery box. Secure cover with two wing nuts.
22. Push table top against wall to release rod. Swing rod out of the way and lower table top down. Secure rod in clip. Secure table top to battery box with strap.

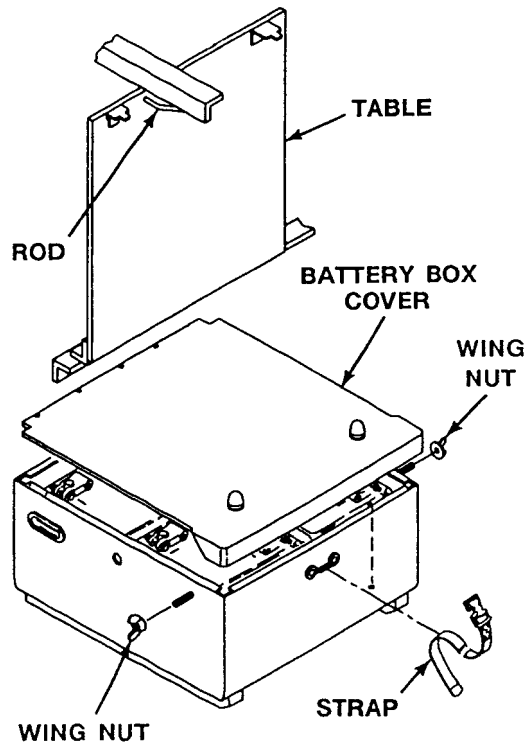

NOTE**Do Step 23 for M58 only.**

23. Close battery box cover and fasten both latches.

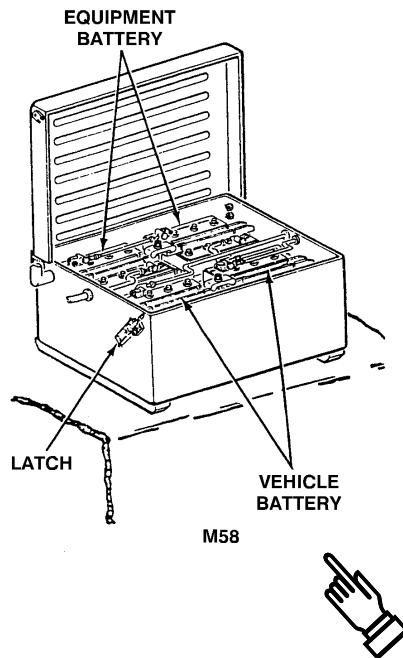

NOTE

Do Step 24 for M113A3 and M1059A3.

24. Install battery box covers and latch six latches securely.

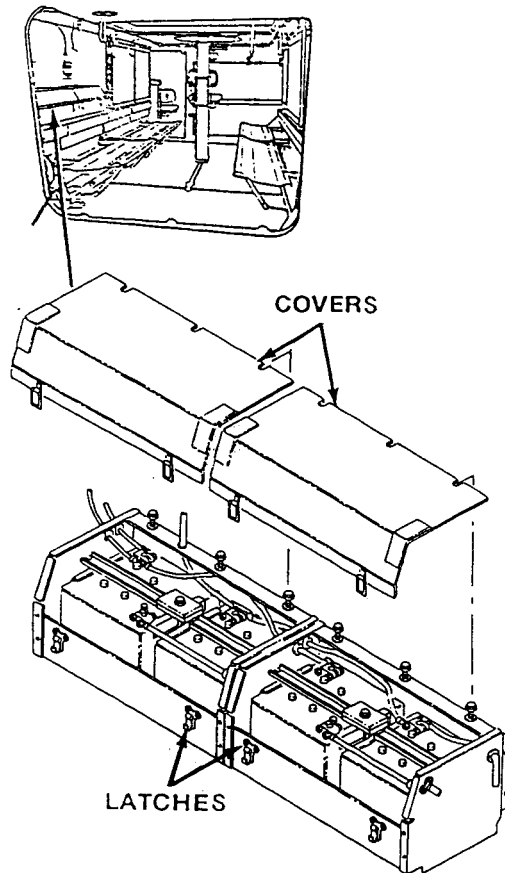
**NOTE**

Do Step 25 for M113A3 only.

25. Slide spall liners to the closed position. See task: POSITIONING SPALL LINERS FOR ACCESS TO EQUIPMENT (WP 0041 00).
26. For more information on batteries, see TM 9-6140-200-14.

END OF TASK

SERVICE BILGE PUMPS

0096 00

THIS WORK PACKAGE COVERS:

- Servicing Front Bilge Pump (page 0096 00-1).
- Servicing Rear Bilge Pump (page 0096 00-5).
- Operational Check (page 0096 00-6).

INITIAL SETUP:

Maintenance Level

Operator

Personnel Required

Driver

Tools and Special Tools

- Cross Tip Screwdriver (WP 0102 00, Item 45)
- Flashlight (WP 0104 00, Item 9)
- Socket Wrench Handle, 1/2 inch drive
(WP 0102 00, Item 30)
- Socket Wrench, 1/2 x 3/4 (WP 0104 00, Item 49)

Helper (H)

Equipment Condition

Engine stopped

SERVICING

FRONT BILGE PUMP

1. Lower trim vane. See task: LOWER/STOW TRIM VANE (WP 0039 00).
2. Open power plant access door. See task: OPEN/CLOSE POWER PLANT ACCESS DOOR (WP 0011 00).
3. Remove four screws, washers and front access cover from hull. Use 1/2 inch drive socket wrench handle and 3/4 inch socket.

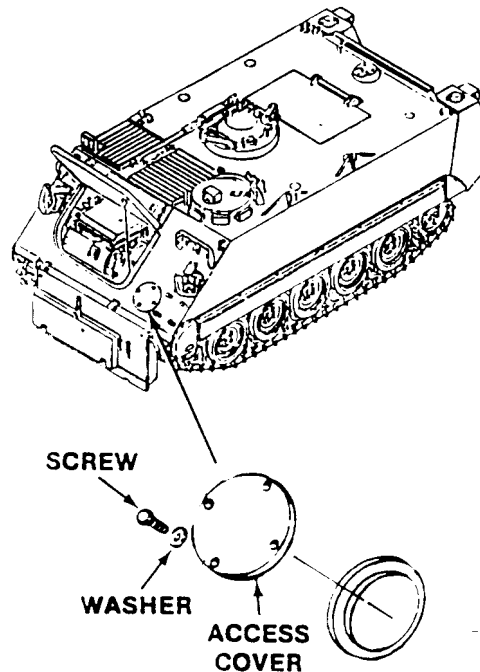

4. Service front bilge pump. Use flashlight.
5. Disconnect lead from bilge pump.
6. Remove two screws, lockwashers, and flat washers securing bilge pump strainer to weld nuts. Remove strainer. Use cross tip screwdriver.

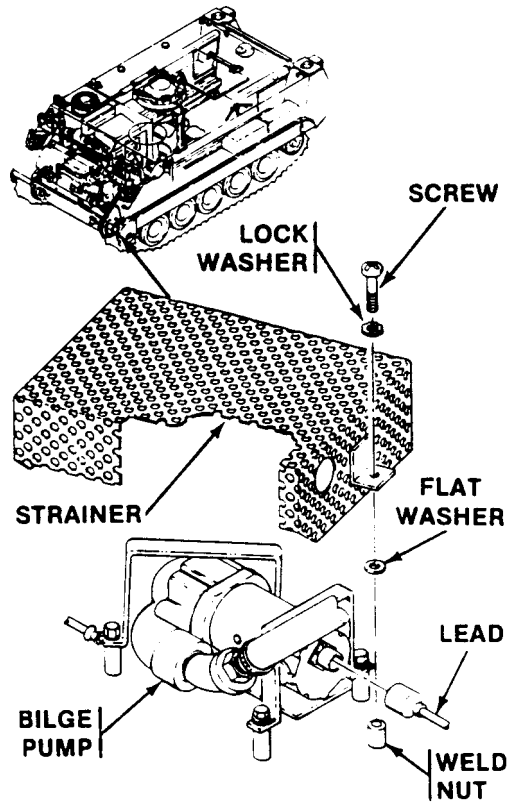

7. Remove mud and debris from bilge pump and strainer. If bilge pump needs additional cleaning, notify unit maintenance.

8. Clean vent hole. Use a wire and run it back and forth in vent hole a few times.

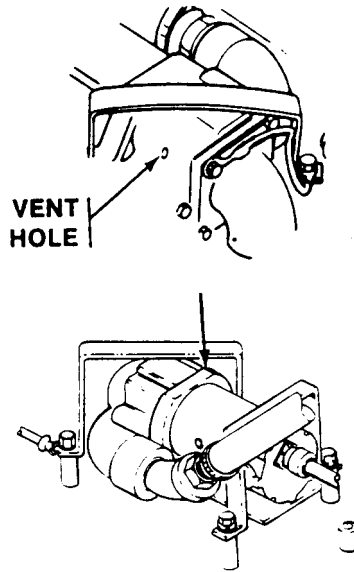

9. Clean front bilge pump outlet line sight glass as needed. If sight glass must be removed to get it clean, notify unit maintenance.

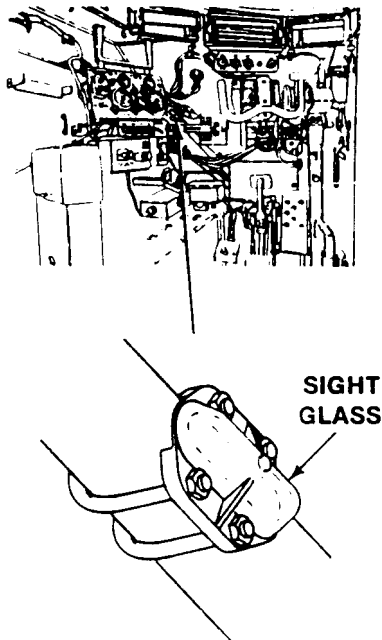

10. Position bilge pump strainer on weld nuts and secure with two flat washers, lockwashers and screws. Use cross tip screwdriver.
11. Connect lead to bilge pump.

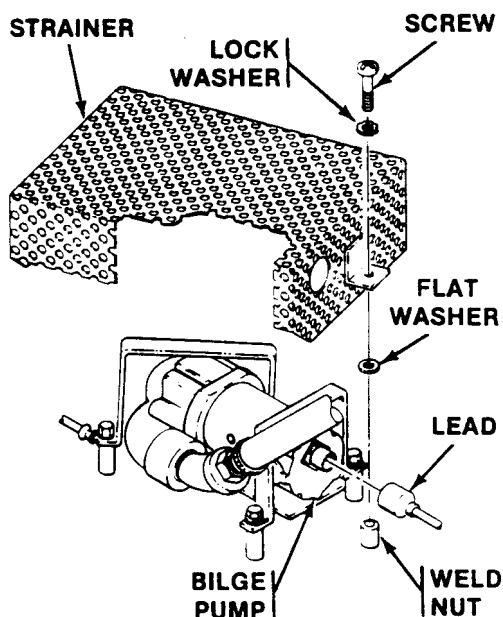

12. Install front access cover on hull and secure with four washers and screws. Use 1/2 inch drive socket wrench handle and 3/4 inch socket.

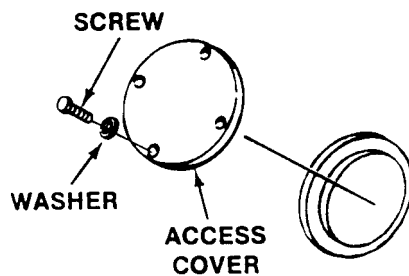

13. Close power plant access door. See task: OPEN/CLOSE POWER PLANT ACCESS DOOR (WP 0011 00).
14. Stow trim vane. See task: LOWER/STOW TRIM VANE (WP 0039 00).

REAR BILGE PUMP

1. Lower ramp. See task: LOWER/RAISE RAMP (WP 0012 00).
2. Remove six screws, washers and rear floor plate from floor supports. Use 1/2 inch drive socket wrench handle and 3/4 inch socket.

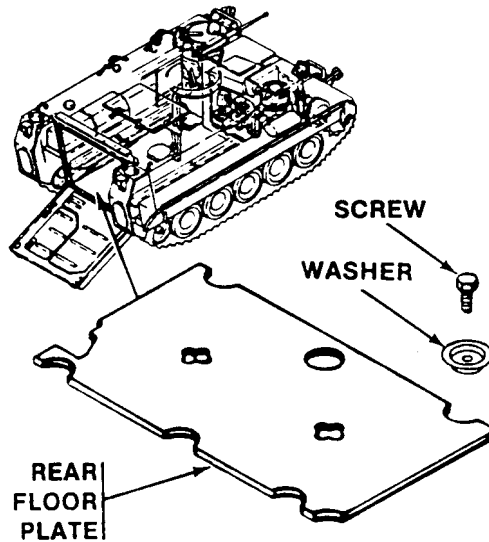

3. Service rear bilge pump. Use flashlight.
4. Remove mud and debris from bilge pump and strainer. If bilge pump needs additional cleaning, notify unit maintenance.
5. Clean vent hole. Use a wire and run it back and forth in vent hole a few times.

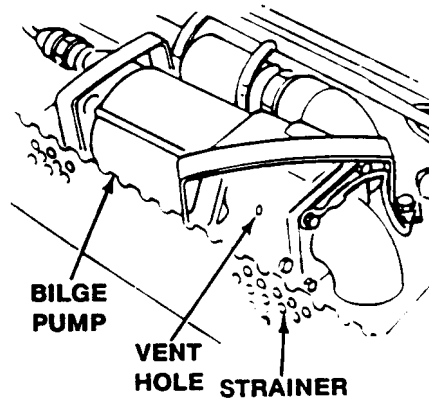

6. Install rear floor plate on floor supports and secure with six washers and screws. Use 1/2 inch drive socket wrench handle and 3/4 inch socket.

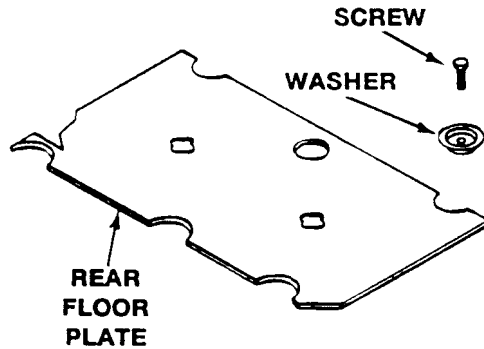

7. Raise ramp. See task: LOWER/RAISE RAMP (WP 0012 00).

OPERATIONAL CHECK

1. Move MASTER SWITCH to ON.
2. Move BILGE PUMPS switch to ON.

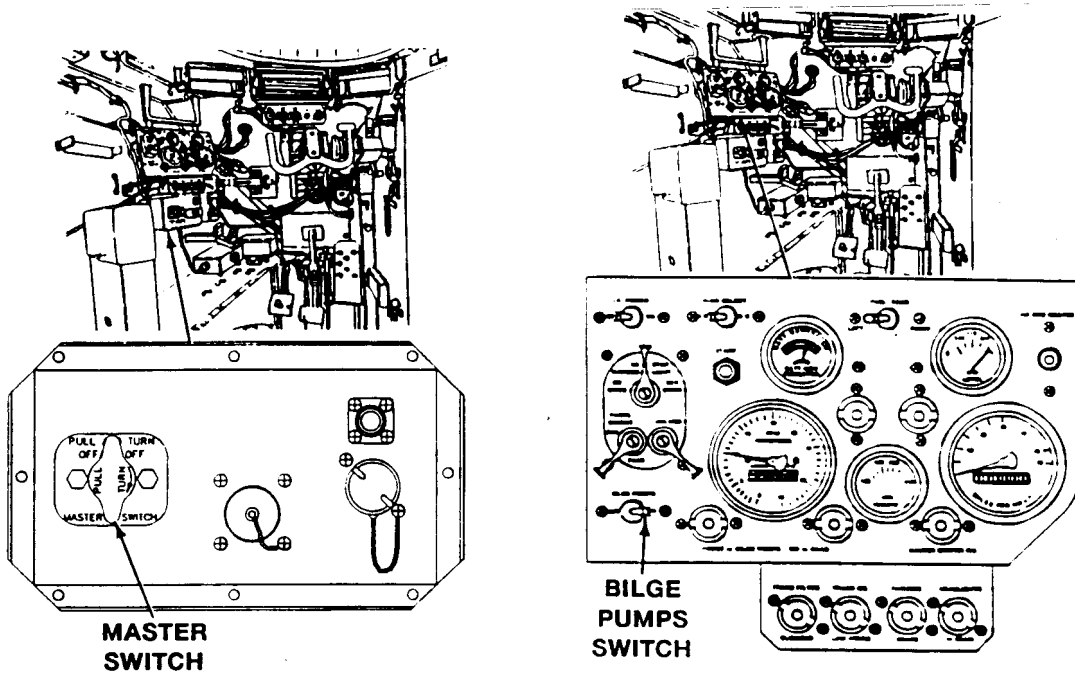

3. (H) Check for air flow at forward and rear bilge pump outlets.

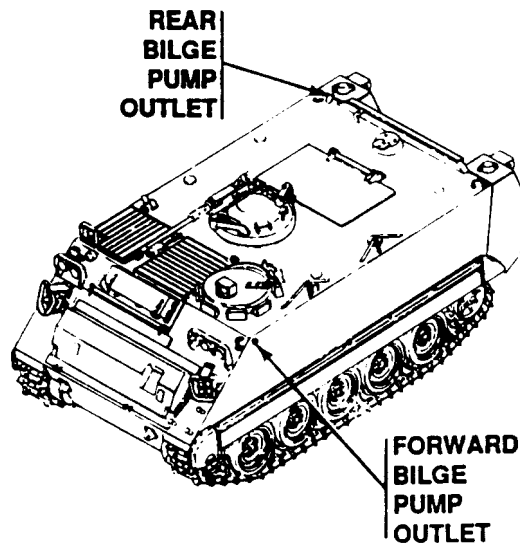

4. Move BILGE PUMPS switch to OFF.
5. Move MASTER SWITCH to OFF.

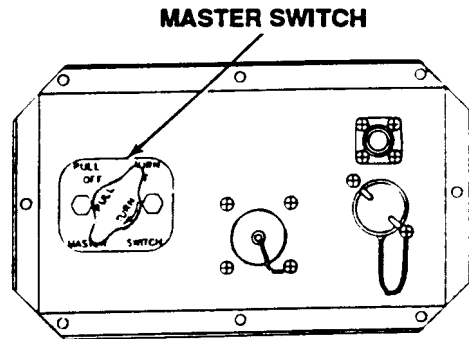
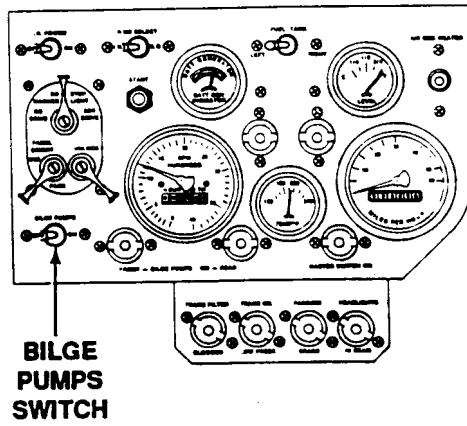

6. If faulty bilge pump(s) is (are) found, notify unit maintenance.

END OF TASK

CHECK/FILL COOLING SYSTEM

0097 00**THIS WORK PACKAGE COVERS:**Operational Check (page 0097 00-1).

INITIAL SETUP:Maintenance Level

Operator

Equipment Condition

Engine stopped

Personnel RequiredDriver

OPERATIONAL CHECK

1. Remove top rear power plant access panel. See task: REMOVE/INSTALL POWER PLANT ACCESS PANELS (WP 0040 00).
2. Reach into power plant compartment and loosen wing nut. Turn thumbscrew to your left to unlock radiator cap combat cover.

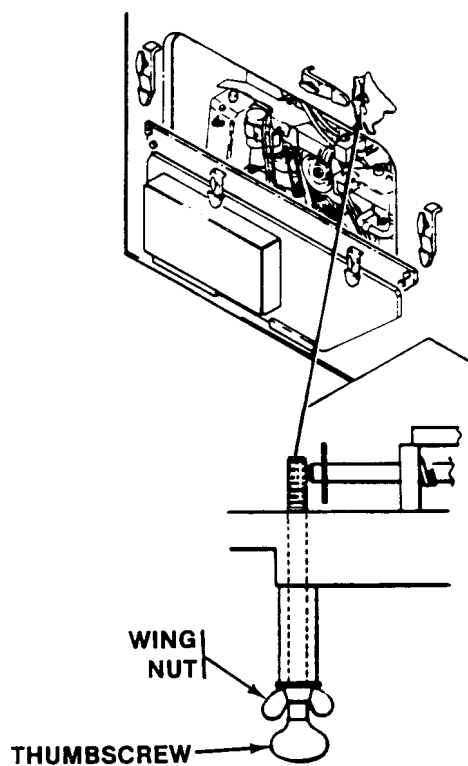

3. Pull combat cover lock handle and open combat cover.

NOTE

Do Step 4 for M577A3 and M1068A3 only.

4. Pull combat cover lock handle. Rotate combat cover to the left or right to access radiator cap.

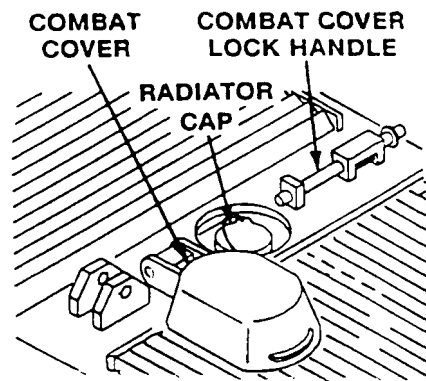
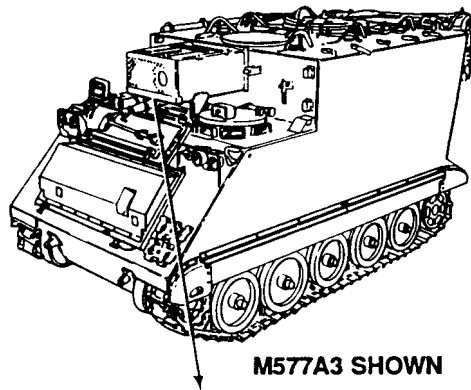

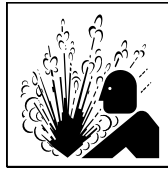
WARNING

Hot radiator coolant can burn you. Use hand to remove cap only if cool to touch. Turn cap slowly to release pressure. Replace cap by pressing down and turning cap until tight.

CAUTION

Adding coolant to an overheated engine could damage engine. Do not add coolant to an overheated engine unless engine is running.

NOTE

Approved antifreeze coolant only may be added to radiator. In an emergency, water may be added if specified coolant is not available.

5. Remove radiator cap and check level of coolant. If coolant is hot, check that coolant reaches HOT FILL LEVEL in filler neck. If coolant is cold, check that coolant reaches COLD FILL LEVEL in filler neck. Add coolant as needed.

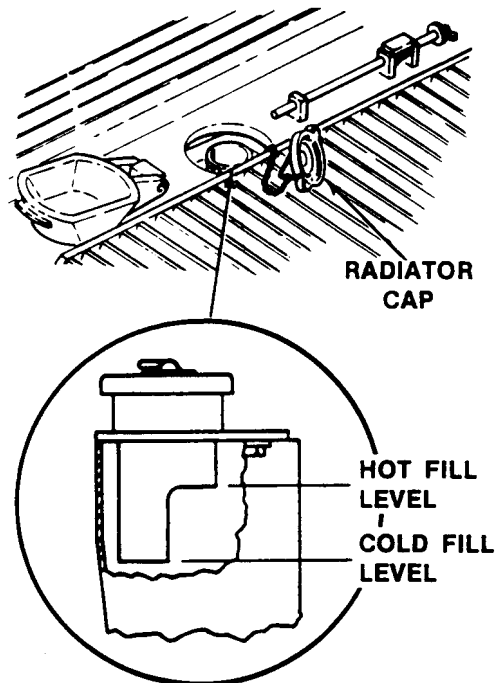

6. If water was added, ask unit maintenance to check antifreeze protection level.

7. Install radiator cap.

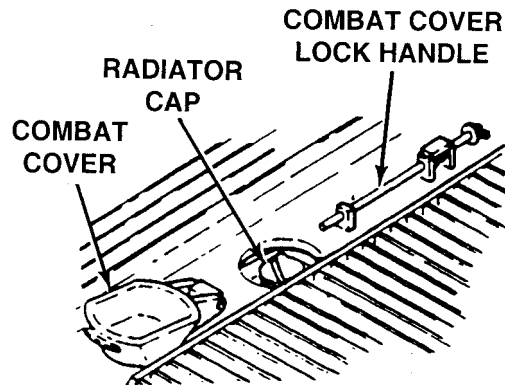

8. Close combat cover. Secure combat cover closed with combat cover lock handle.

NOTE

Do Step 9 for M577A3 and M1068A3 only.

9. Rotate combat cover over radiator cap. Secure combat cover closed with combat cover lock handle.

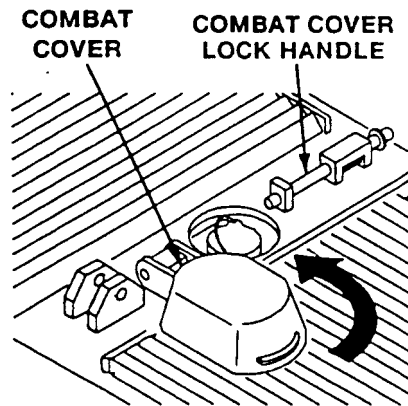

10. Reach into power plant compartment and turn thumbscrew to your right until tight. Secure with wing nut.

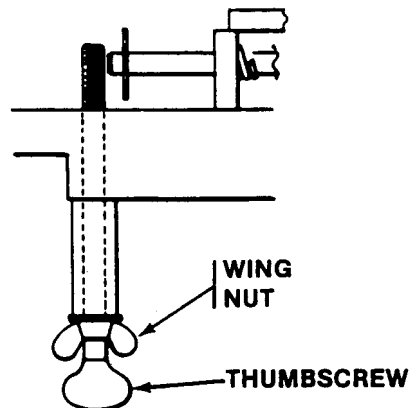

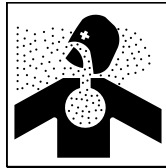
WARNING

Engine exhaust fumes can kill you. Do not operate the carrier with access panels off. Make sure the panels are sealed tight. See warning in the front of this manual.

11. Install the top rear power plant access panel. See task: REMOVE/INSTALL POWER PLANT ACCESS PANELS (WP 0040 00).

END OF TASK

MAINTENANCE OF AIR CLEANER

0098 00

THIS WORK PACKAGE COVERS:

Operational Check (page 0098 00-1).

INITIAL SETUP:

Maintenance Level

Operator

Equipment Condition

Engine stopped

Personnel Required

Driver

OPERATIONAL CHECK

WARNING

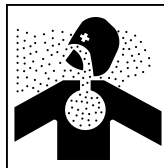

Failure to decontaminate and wear protective clothing after NBC attack could result in serious health hazards to personnel. Do not service air cleaner or vent system after NBC attack until carrier has been decontaminated.

CAUTION

Operating carrier with air cleaner missing or damaged can cause extensive engine damage. Do not operate carrier if air cleaner element is missing or door or gasket is missing or damaged.

1. Lower trim vane. See task: LOWER/STOW TRIM VANE (WP 0039 00).
2. Open power plant access door. See task: OPEN/CLOSE POWER PLANT ACCESS DOOR (WP 0011 00).

3. Release latch at top of air cleaner housing. Swing door up and remove door. Check latch for proper operation.

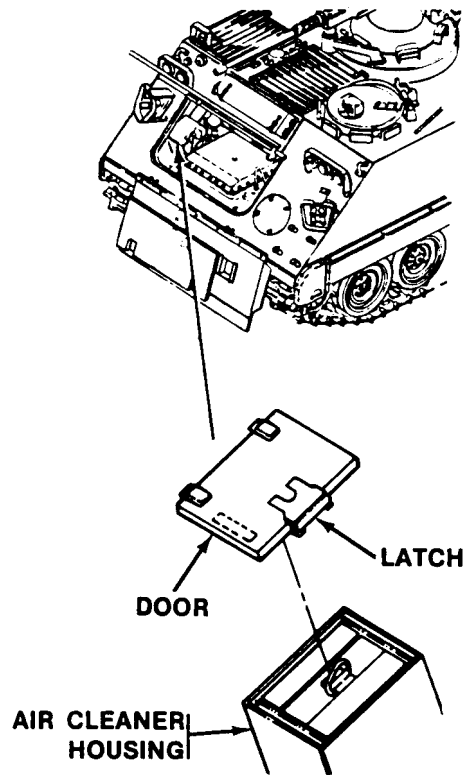

4. Check door for missing or damaged gasket.
5. Check that air cleaner element is installed in air cleaner housing.
6. Install door on air cleaner housing and secure with latch.

7. Check air cleaner restriction indicator. If at any time you see only red in the window and button does not reset when pushed in, notify unit maintenance.

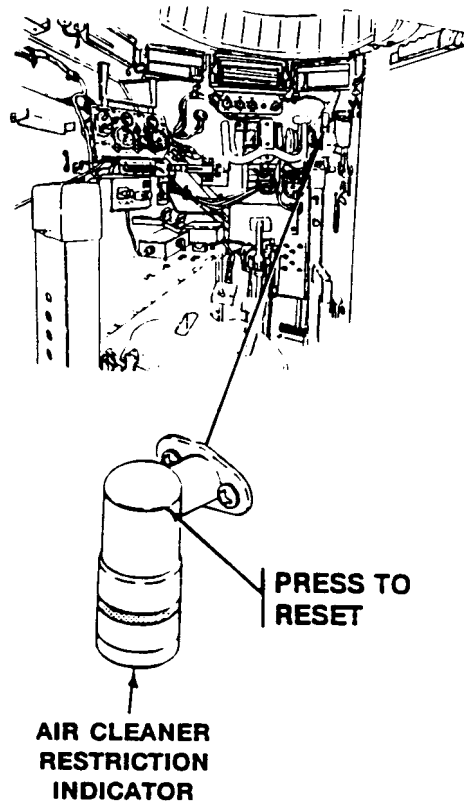

8. Close power plant access door. See task: OPEN/CLOSE POWER PLANT ACCESS DOOR (WP 0011 00).
9. Stow trim vane. See task: LOWER/STOW TRIM VANE (WP 0039 00).

END OF TASK

CHECK/REPLACE MISSING PLUG (M113A3 ONLY)

0099 00

THIS WORK PACKAGE COVERS:

- Removal (page 0099 00-1).
- Installation (page 0099 00-1).

INITIAL SETUP:

Maintenance Level
Operator

Personnel Required
Soldier

Tools and Special Tools
Flat tip screwdriver (WP 0102 00, Item 46)

Equipment Condition

Materials/Parts
Cleaning compound solvent (WP 0104 00, Item 6)

Engine stopped (WP 0024 00)

REMOVAL

NOTE

Armor mounting provision holes must be free of dust and dirt before plugs are installed.

1. Remove plug from armor mounting provision hole. Use flat tip screwdriver.

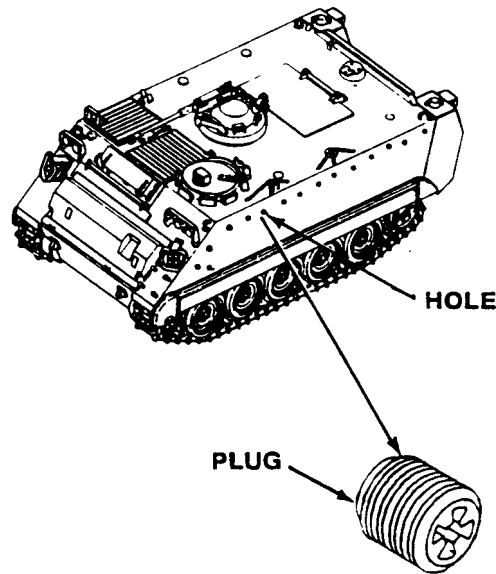

2. Clean armor mounting provision hole. If necessary, use cleaning compound solvent. Let surface air dry.

INSTALLATION

1. Install new plug in armor mounting provision hole. Use flat tip screwdriver.

END OF TASK

SERVICE SMOKE GENERATOR FUEL CAN/FOG OIL TANK (M1059A3)

0100 00

THIS WORK PACKAGE COVERS:

- Remove Smoke Generator Fuel Can (page 0100 00-2).
- Service Smoke Generator Fuel Can (page 0100 00-3).
- Install Smoke Generator Fuel Can (page 0100 00-4).
- Service Fog Oil Tank (page 0100 00-4).

INITIAL SETUP:

Maintenance Level

Operator

Personnel Required

Driver

References

TM 3-1040-283-10

Equipment Condition

Engine stopped (WP 0024 00)

Carrier blocked (WP 0042 00)

WARNING



Fuel is highly flammable and can catch fire quickly. Use extreme caution when working around fuel and keep all flames and sparks a minimum of 25 feet away. If fuel gets on your skin it can cause burns or rashes. Wash skin immediately with soap and water and seek medical attention.

CAUTION

Fuel cans, hoses, and fittings should be cleaned prior to removal and installation or damage to equipment may result.

NOTE

There are two smoke generator fuel cans. Procedures for servicing the right and left fuel cans are the same.

SERVICING**REMOVE SMOKE GENERATOR FUEL CAN****CAUTION**

Fuel cans, hoses, and fittings should be cleaned prior to removal and installation or damage to equipment may result.

1. Disconnect fuel return and supply hoses from tube adapters.
2. Disconnect fuel vent hose from tube adapter.
3. Release fuel can straps and lift fuel can off support bracket on hull.
4. Remove fuel can lid assembly from fuel can.

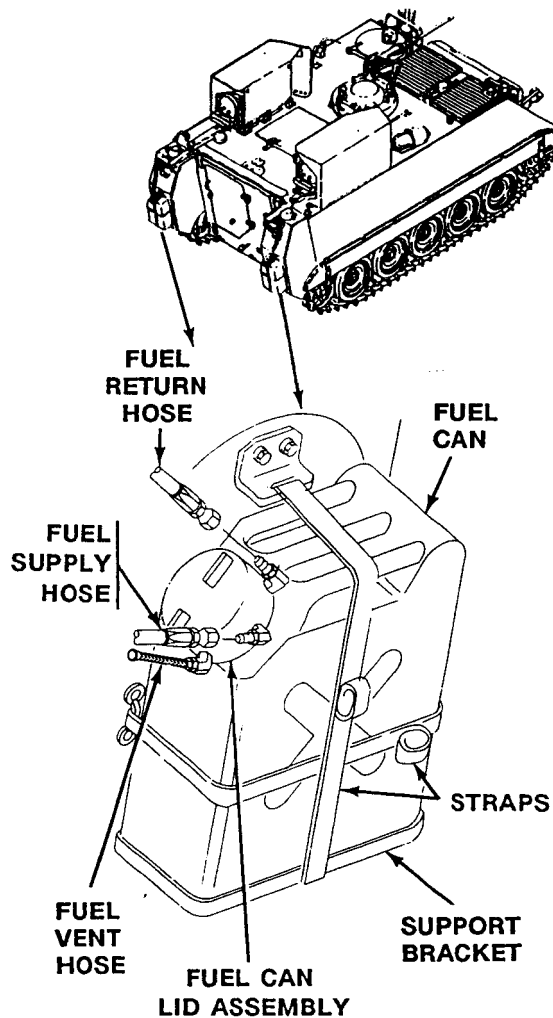

SERVICE SMOKE GENERATOR FUEL CAN

WARNING



Do not fill fuel can with smoke generator running, while smoking, or when near an open flame. Never overfill the fuel can or spill fuel. An explosion can be caused, and death or injury to personnel may result. If fuel is spilled, clean it up immediately.

1. Fill fuel can with fuel (gasoline) as required.

INSTALL SMOKE GENERATOR FUEL CAN**CAUTION**

Fuel cans, hoses, and fittings should be cleaned prior to removal and installation or damage to equipment may result.

1. Install fuel can lid assembly on fuel can.
2. Position fuel can on support bracket on hull and secure with fuel can straps.
3. Connect fuel vent hose to tube adapter.
4. Connect fuel return and supply hoses to tube adapters.

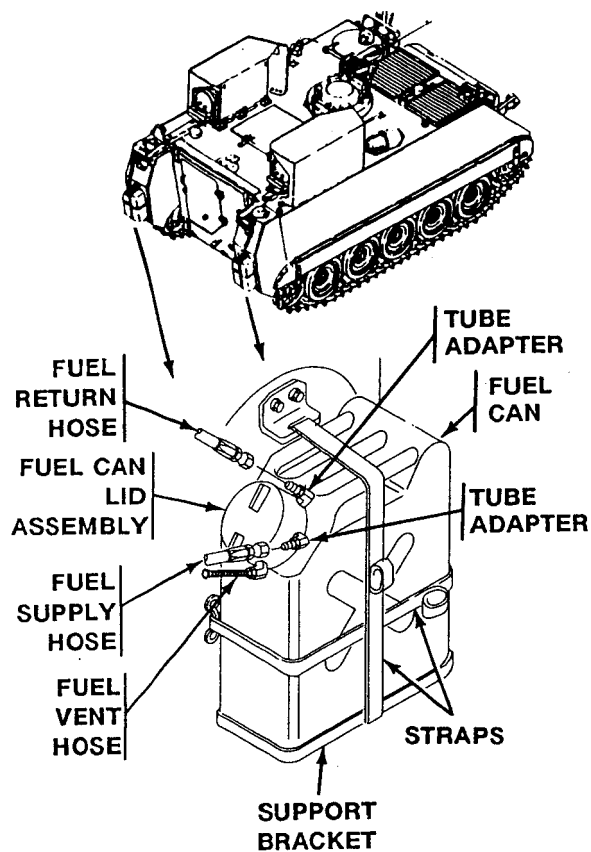
**SERVICE FOG OIL TANK**

1. See TM 3-1040-283-10 for proper servicing.

END OF TASK

CHAPTER 5

OPERATOR SUPPORTING INFORMATION

WORK PACKAGE INDEX

<u>Title</u>	<u>Sequence No.</u>
REFERENCES.....	.0101 00
COMPONENTS OF END ITEM (COEI) AND BASIC ISSUE ITEMS (BII) LISTS.....	.0102 00
ADDITIONAL AUTHORIZATION LIST (AAL).....	.0103 00
EXPENDABLE AND DURABLE ITEMS LIST.....	.0104 00
STOWAGE AND SIGN GUIDE.....	.0105 00
STANDARD LOAD PLAN.....	.0106 00
PLUG/SETSCREW GUIDE FOR ARMOR MOUNTING PROVISION HOLES.....	.0107 00

REFERENCES

0101 00

SCOPE

This work package lists all forms, field manuals, technical manuals and miscellaneous publications referred to in this manual.

FORMS

Equipment Inspection and Maintenance Worksheet.....DA Form 2404
 Oil Analysis Request.....DD Form 2026
 Product Quality Deficiency Report.....SF 368
 Recommended Changes to Equipment Technical Publications.....DA Form 2028

FIELD MANUALS

Field Hygiene and Sanitation.....FM 21-10
 First Aid for Soldiers.....FM 4-25.11
 Operation and Maintenance of Ordnance Materiel in Cold WeatherFM 9-207
 Vehicle Recovery Operations.....FM 20-22

TECHNICAL MANUALS

Destruction of Conventional Ammunition and Improved Conventional Munitions (ICM) to Prevent Enemy Use.....TM 43-0002-33
 Operator’s Manual for Chemical-Biological Mask: Field, M40A1; Chemical-Biological Mask: Combat Vehicle, M42A2TM 3-4240-346-10
 Operator’s Manual for Generator Set, Smoke, Mechanical: Pulse Jet, M157A2.....TM 3-1040-283-10
 Operator’s Manual for Generator, Smoke, Mechanical: Mechanized Smoke Obscurant System, M58.....TM 3-1040-285-10
 Operator’s Manual for Mortar Fire Control System, M95.....TM 9-1220-248-10
 Operator’s Manual for Mortar Fire Control System, M96.....TM 9-1220-249-10
 Operator’s Manual for Mortar, 120 mm: Towed M120 and Mortar, 120 mm: Carrier Mounted M121.....TM 9-1015-250-10
 Operator’s Manual for Radio Sets.....TM 11-5820-401-10-2
 Operator’s Manual for SINCGARS Ground Combat Net Radio, ICOM Manpack Radio, AN/PRC-119A, Short Range Vehicular Radio AN/VRC-87A, Short Range Vehicular Radio with Single Radio Mount AN/VRC-87C, Short Range Vehicular Radio with Dismount AN/VRC-88A, Short Range/Long Range Vehicular Radio AN/VRC-89A, Long Range Vehicular Radio AN/VRC-90A, Short Range/Long Range Vehicular Radio with Dismount AN/VRC-91A, Short Range/Long Range Vehicular Radio AN/VRC-92A used with Automated Net Control Device (ANCD) (AN/CYZ-10) Precision Lightweight Gps Receiver (PLGR) (AN/PSN-11) Secure Telephone Unit (STU) Frequency Hopping Multiplexer (FHMUX)TM 11-5820-890-10-8
 Operator’s Manual for Tester, Airflow, Gas-Particulate Filter Unit: M39TM 3-6680-316-10
 Operator’s Manual for Vehicle Intercommunications System AN/VIC-3(V).....TM 11-5830-263-10
 Operator’s Manual for Viewer, Driver’s Night Vision AN/VVS-2(V)1TM 11-5855-249-10
 Operator’s Manual: Machine Guns, Caliber .50; M2.....TM 9-1005-213-10

REFERENCES — Continued

0101 00

Operator’s Manual: Machine Gun, 40 mm, MK19, Mod 3TM 9-1010-230-10

Operator’s and Organizational Maintenance Manual: Radio SetsTM 11-5820-498-12

Operator’s and Unit Maintenance Manual (Including Repair Parts and Special Tools Lists) for
Driver’s Vision Enhancer.....TM 11-5855-311-12&P

Operator’s and Unit Maintenance Manual (Including Repair Parts and Special Tools Lists)
M1068 Standardized Integrated Command Post System (SICPS).....TM 11-7010-256-12&P

Operator’s, Organizational, Direct Support and General Support Maintenance Manual, for
Generator Set; Gasoline Engine Driven 4.2 KW, +28VDC.....TM 5-6115-596-14

Operator, Unit, Direct Support, and General Support Maintenance Manual (Including Repair
Parts and Special Tools List) for Heater, Vehicular Compartment Model: A-20.....TM 9-2540-207-14&P

Operator’s, Organizational, Direct Support and General Support Maintenance Manual for
Headset-Microphone Kit, MK-1697/GTM 11-5965-286-14

Operator’s, Organizational, Direct Support and General Support Maintenance Manual:
Suppressor, Electrical Transient MX-7778A/GRCTM 11-5915-224-14

Operator’s, Unit, and Direct Support Maintenance Manual with Repair Parts and Special
Tools List, 5KW, 28VDC Auxiliary Power Unit (APU).....TM 9-6115-664-13&P

Operator’s, Unit, and Direct Support Maintenance Manual Including Repair Parts and Special
Tools List for Modular Command Post System (MCPS).....TM 10-5410-229-13&P
Superseded by TM
10-8340-243-13&P

Operator’s, Unit, Direct Support and General Support Maintenance Manual for Lead-Acid
Storage Batteries.....TM 9-6140-200-14

Organizational, Direct Support, General Support, and Depot Maintenance Manual: Antenna
Equipment, RC-292TM 11-5820-348-15

Organizational Maintenance Manual: Carrier, Personnel, Full Tracked, Armored M113A3.....TM 9-2350-277-20

Procedures for Destruction of Electronics Materiel to Prevent Enemy Use.....TM 750-244-2

Procedures for Destruction of Equipment in Federal Supply Classifications 1000, 1005, 1010,
1015, 1020, 1025, 1030, 1055, 1090, and 1095 to Prevent Enemy Use.....TM 750-244-7

Procedures for Destruction of Tank-Automotive Equipment to Prevent Enemy Use.....TM 750-244-6

OTHER PUBLICATIONS

Army Oil Analysis Program (AOAP) Guide for Leaders and Users.....TB 43-0211

Heat Stress Control and Heat Casualty Management.....TB Med 507

The Army Maintenance Management System (TAMMS) User’s Manual.....DA PAM 750-8

MILITARY SPECIFICATIONS

Carriers, Personnel, Full-Tracked, Armored: M113A2 and M113A3; Mortars, Self-Propelled:
M106A2 (107mm), M125A2 (81mm) and M1064, M1064A3 (120mm); Smoke
Generators: M1059, M1059A3 and M58; Processing for Storage and Shipment ofMIL-DTL-45360

Fuel Oil, Diesel; for Posts, Camps and StationsA-A-52557

Grease, Automotive and ArtilleryMIL-PRF-10924

REFERENCES — Continued

0101 00

Grease, Wire Rope - Exposed Gear	MIL-PRF-18458
Hydraulic Fluid, Rust Inhibited, Fire Resistant, Synthetic Hydrocarbon Base, Nato Code No. H-544	MIL-PRF-46170
Lubricating Oil, Gear Multipurpose (Metric) Military Use	SAE J2360
Lubricating Oil, Internal Combustion Engine, Arctic	MIL-PRF-46167
Lubricating Oil, Internal Combustion Engine, Combat/Tactical Service	MIL-PRF-2104
Lubricating Oil, Internal Combustion Engine, Preservative Break-In	MIL-PRF-21260
Lubricating Oil, Preservative, Medium	MIL-PRF-3150

COMPONENTS OF END ITEM AND BASIC ISSUE ITEMS**0102 00****INTRODUCTION****Scope**

This work package lists COEI and BII for the M113A3 FOV carriers to help you inventory items required for safe and efficient operation of the equipment.

The COEI and BII lists for subordinate systems are contained in the following TMs:

<u>System</u>	<u>TM</u>
M1064A3 120-mm Mortar M121	TM 9-1015-250-10
M1068A3 MCPS	TM 10-8340-243-13&P
M1068A3 SICPS	TM 11-7010-256-12&P
M58 Smoke Obscurant System	TM 3-1040-285-10
M1059A3 Smoke Generator	TM 3-1040-283-10

NOTE

Some of the BII items covered by TM 3-1040-285-10 will be located in the tool bag which is part of BII in this appendix.

General

The COEI and BII information is divided into the following lists:

Components of End Item. This list is for information purposes only and is not authority to requisition replacements. These items are part of the M113A3 FOV carrier. As part of the end item, these items must be with the end item whenever it is issued or transferred between property accounts. Items of COEI are removed and separately packaged for transportation or shipment only when necessary. Illustrations are furnished to help you find and identify the items.

Basic Issue Items. These essential items are required to place the M113A3 FOV carrier in operation, operate it, and to do emergency repairs. Although shipped separately packaged, BII must be with the M113A3 FOV carrier during operation and when it is transferred between property accounts. Listing these items is your authority to request/requisition them for replacement based on authorization of the end item by the TOE/MTOE. Illustrations are furnished to help you find and identify the items.

Explanation of Columns in the COEI List and BII List

Column (1) — Illus Number. Gives you the number of the item illustrated.

Column (2) — National Stock Number (NSN). Identifies the stock number of the item to be used for requisitioning purposes.

Column (3) — Description, CAGEC, and Part Number. Identifies the Federal item name (in all capital letters) followed by a minimum description when needed. The stowage location of COEI and BII is also included in this column. The last line below the description is the CAGEC (Commercial and Government Entity Code) (in parentheses) and the part number.

Column (4) — Usable On Code. When applicable, gives you a code if the item you need is not the same for different models of equipment. These codes are identified below:

<u>Code</u>	<u>Used On</u>
APC	M113A3
AP2	M1064A3
AP3	M1068A3
AP5	M577A3

COMPONENTS OF END ITEM AND BASIC ISSUE ITEMS — Continued

0102 00

<u>Code</u>	<u>Used On</u>
AP6	M1059A3
AP8	M58

Column (5) — Unit of Measure (U/M). Indicates the physical measurement or count of the item as issued per the National Stock Number shown in column (2).

Column (6) — Qty Rqr. Indicates the quantity required.

COMPONENTS OF END ITEM (COEI) LIST

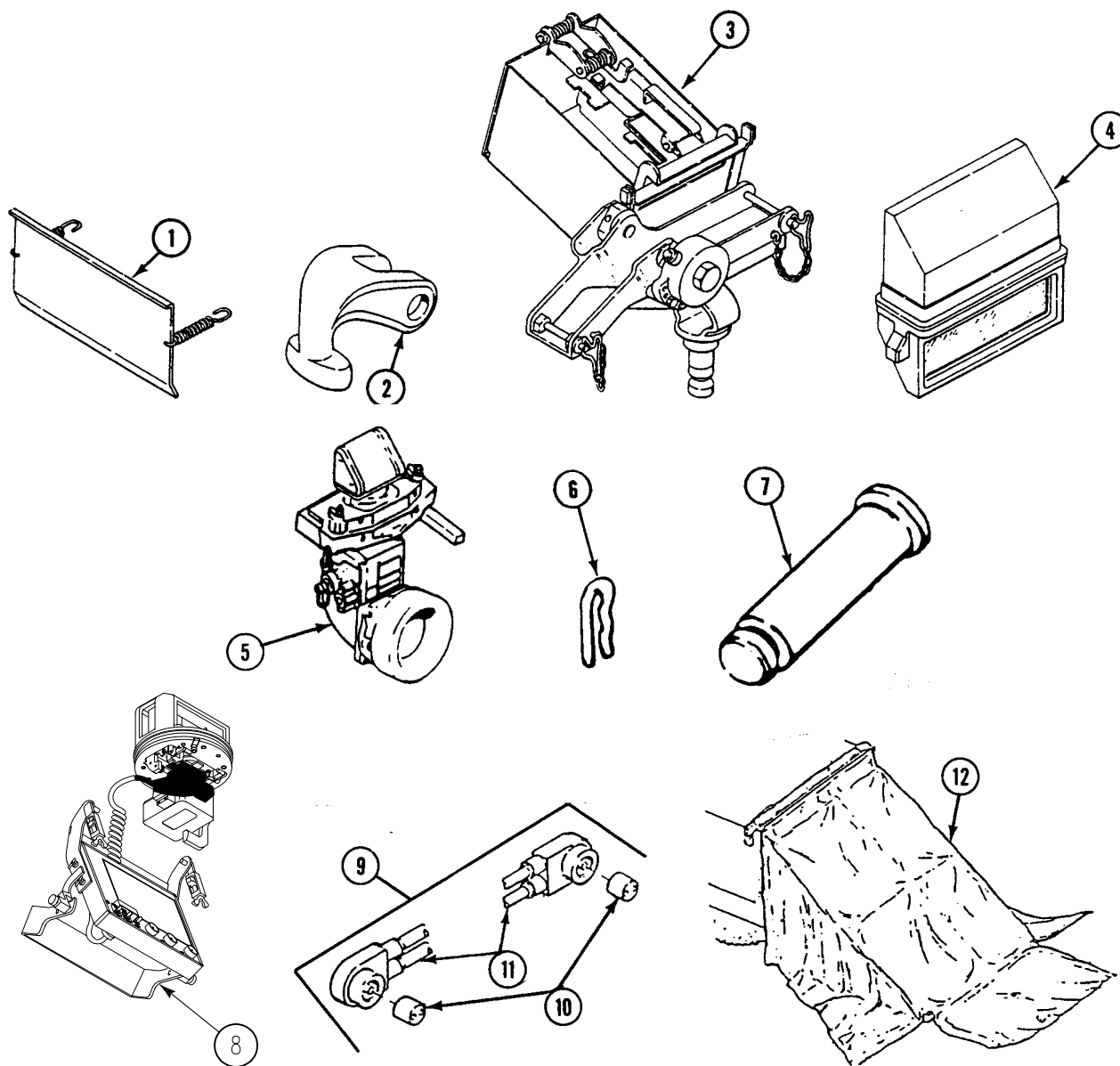

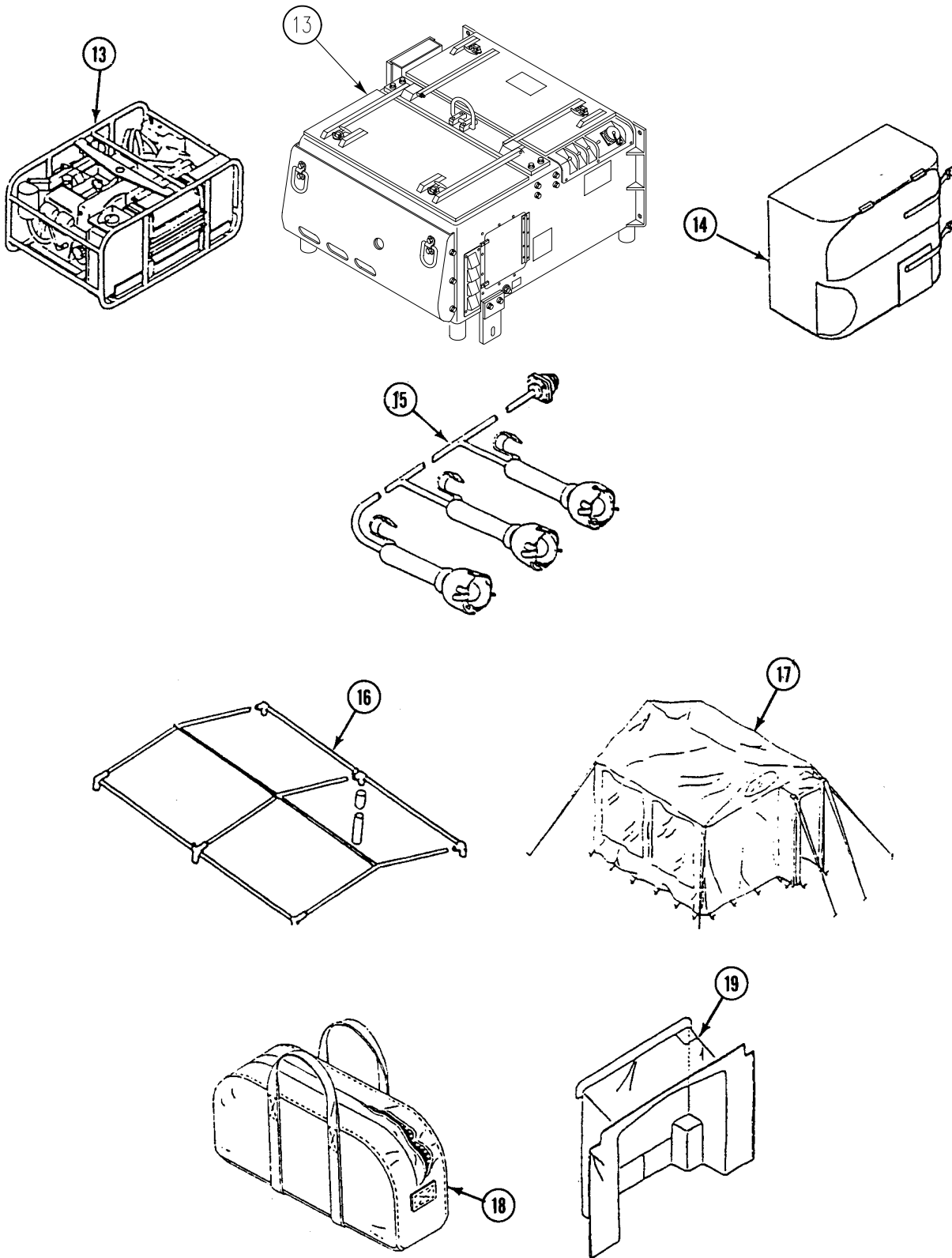

COMPONENTS OF END ITEM AND BASIC ISSUE ITEMS — Continued

0102 00

Table 1. Components of End Item List

(1) ILLUS NUMBER	(2) NATIONAL STOCK NUMBER	(3) DESCRIPTION, CAGEC, AND PART NUMBER	(4) USABLE ON CODE	(5) U/M	(6) QTY RQR
1	2590-00-898-6771	COVER, PERISCOPE (ON M17 PERISCOPE) (19207) 10866115	APC, AP2, AP6, AP8	EA	9
1	2590-00-898-6771	COVER, PERISCOPE (ON M17 PERISCOPE) (19207) 10866115	AP3, AP5	EA	4
2	2540-00-679-8035	HOOK, TOW (ON FRONT AND REAR TOWING EYES) (19207) 10861607	APC, AP2, AP6, AP8	EA	2
2	2540-00-679-8035	HOOK, TOW (ON REAR TOWING EYES) (19207) 10861607	AP5, AP3	EA	2
3	1005-00-704-6650 OR	MOUNT, MACHINE GUN (ON COMMANDER'S CUPOLA) (19204) 7046650	APC, AP2, AP6, AP8	EA	1
3	1005-00-836-7286	MOUNT, MACHINE GUN (ON COMMANDER'S CUPOLA) (19207) 83672862	APC, AP2, AP6, AP8	EA	1
4	6550-01-317-9138	PERISCOPE, M17 (LASER PROTECTION) (19207) 12357918-2	APC, AP2, AP6, AP8	EA	10
4	6550-01-317-9138 OR	PERISCOPE, M17 (ON DRIVER'S STATION) (19207) 12357918-2	AP5, AP3	EA	4
4	6650-00-704-3549	PERISCOPE, M17 (9) AROUND DRIVER'S AND COMMANDER'S STATION (1) ON RIGHT REAR WALL (19200) 7043549	APC	EA	10
4	6650-00-704-3549	PERISCOPE, M17 (9) AROUND DRIVER'S AND COMMANDER'S STATION (1) ON SPONSON, RIGHT REAR (19200) 7043549	AP2, AP8	EA	10
5	5855-01-096-0871	VIEWER, DRIVER'S NIGHT VISION (ON WALL LEFT OF DRIVER) (80063) AN/VVS-2(V)1A	APC, AP2, AP6, AP5, AP3	EA	1
6	5315-00-598-5808	PIN, LOCK, TOW HOOK/CABLE (ON TOW HOOKS) (19207) 7752865	APC, AP2, AP6, AP8, AP5, AP3	EA	2
7	5315-00-862-2683	PIN, STRAIGHT, TOW HOOK (ON TOW HOOK) (19207) 10890323	APC, AP2, AP6, AP8, AP5, AP3	EA	2
8	5855-01-450-8108	VIEWER, DRIVER'S NIGHT VISION (ON WALL LEFT OF DRIVER) (80063) AN/VVS-5 DVE (V)3	AP8	EA	1
9	6150-00-363-7102	CABLE KIT (NATO, ON TOP DECK) (19207) 11682379-2	AP5	EA	1

COMPONENTS OF END ITEM AND BASIC ISSUE ITEMS — Continued

0102 00

(1) ILLUS NUMBER	(2) NATIONAL STOCK NUMBER	(3) DESCRIPTION, CAGEC, AND PART NUMBER	(4) USABLE ON CODE	(5) U/M	(6) QTY RQR
10	5935-00-322-8959	ADAPTER (19207) 11677570	AP5, AP3	EA	2
11	6150-01-310-1829	CABLE ASSEMBLY (NATO, ON TOP DECK) (19207) 11682336-2 SEE TM 9-2350-277-24P FOR REPAIR PARTS. ()	AP5, AP3	EA	1
12	8340-00-134-7512	COVER, TENT (19207) 11617260	AP5	EA	1
13	6115-00-857-1397 OR	4.2 KW GENERATOR SET AND COVER (19207) 10919300	AP5, AP3	EA	1
13	6115-01-452-6513	5.0 KW AUXILIARY POWER UNIT (APU) (30554) MEP-952B	AP3, AP5	EA	1
14	2540-00-066-4281	COVER ASSEMBLY, AUXILIARY GENERATOR (FOR 4.2 KW ONLY) (19207) 10932720	AP5, AP3	EA	1
15	6250-00-933-6964	LAMP HOLDER ASSEMBLY (IN TOOL BAG) (19207) 10918129	AP5	EA	2
16	2540-00-003-8339	TENT FRAME (19207) 10918155	AP5	EA	1
17	5410-00-323-2454 OR	GREEN MODULAR COMMAND POST SYSTEM (81337) 5-4-6340-1	AP3	EA	1
17	5410-00-334-7529	TAN MODULAR COMMAND POST SYSTEM (81337) 5-4-6340-2	AP3	EA	1
18	5820-01-263-1760	GROUNDING KIT (80063) SC-D-681610	AP3	EA	1
19	8340-01-378-8301 OR	BOOTWALL ASSEMBLY (GREEN) (81337) 5-4-7484-1	AP3	EA	1
19	8340-01-300-2241	BOOTWALL ASSEMBLY (TAN) (81337) 5-4-7484-2	AP3	EA	1

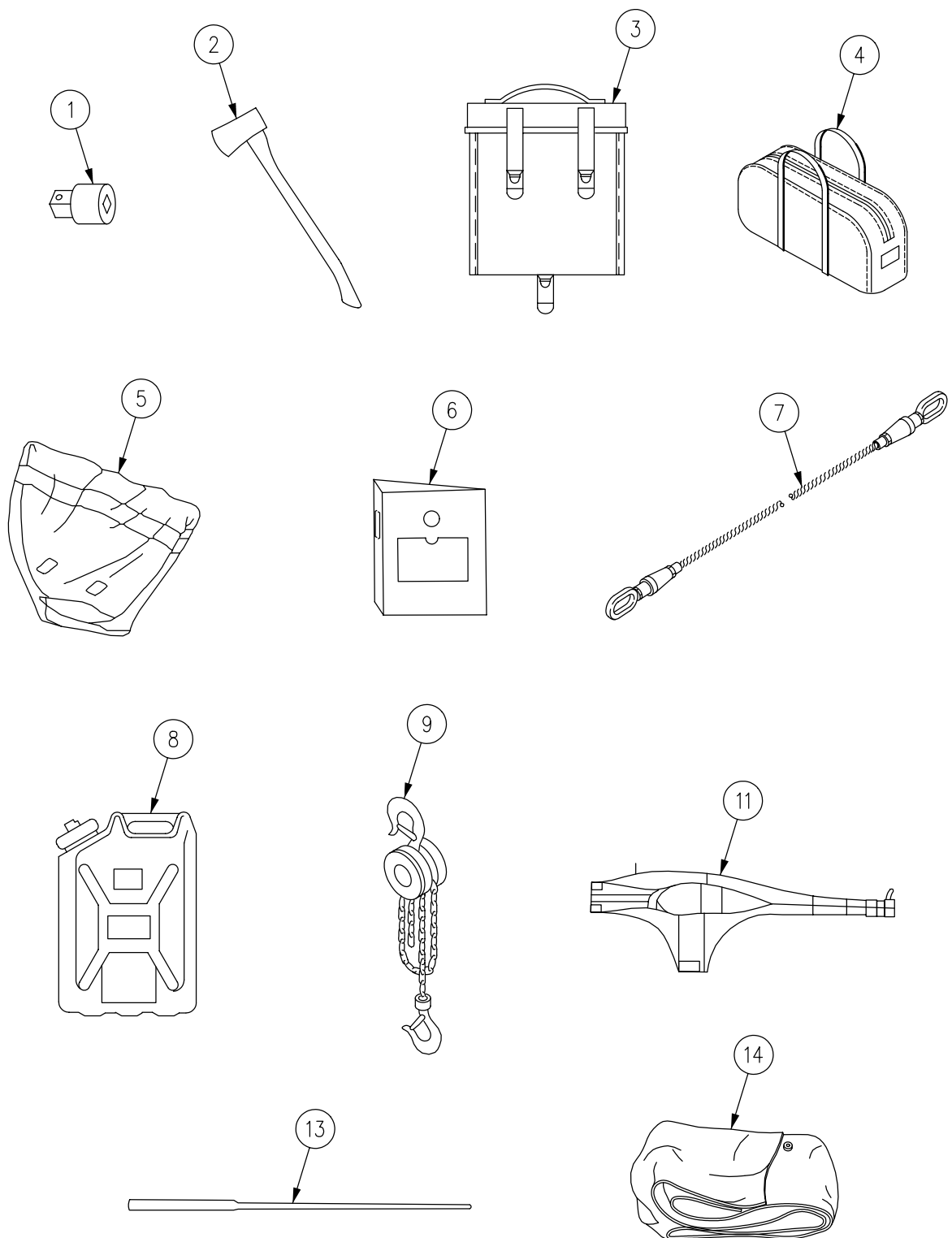

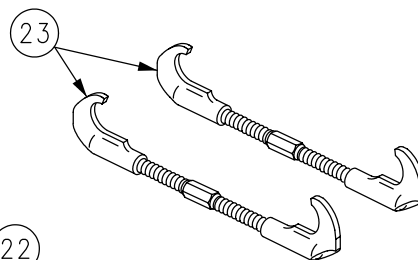
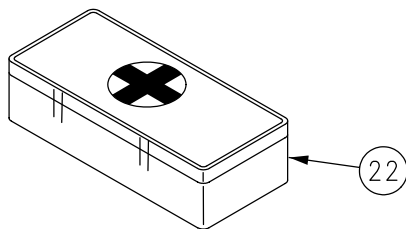
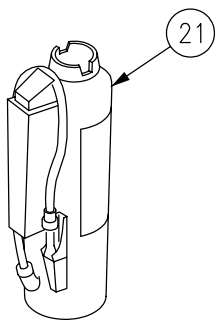
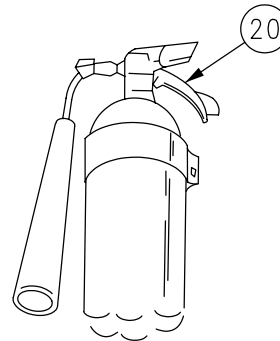
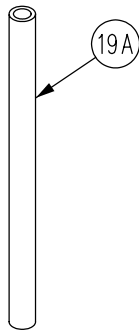
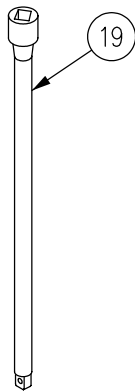
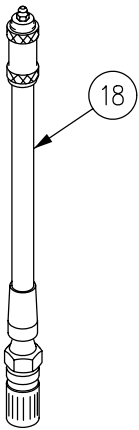
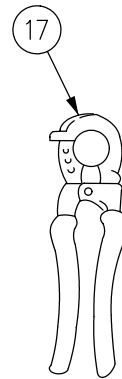
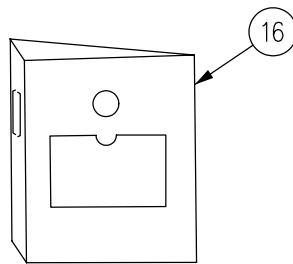
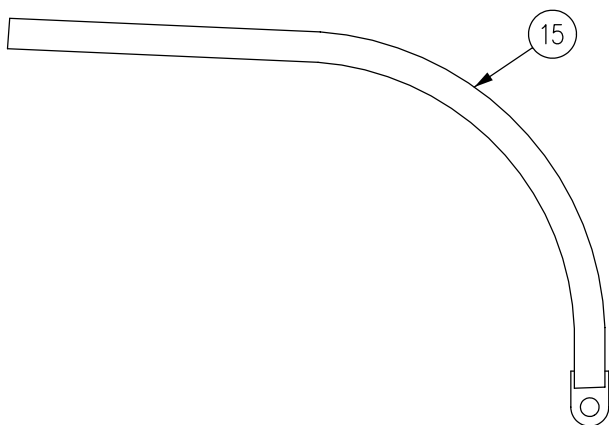

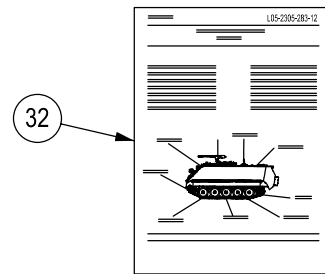
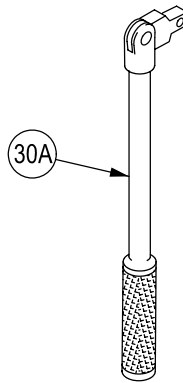
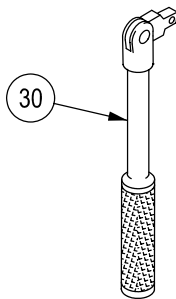
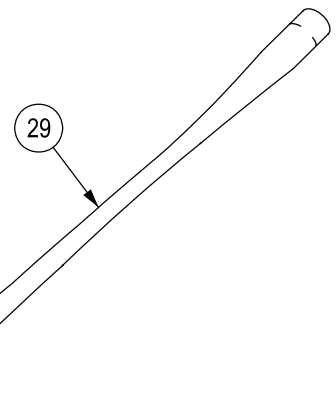
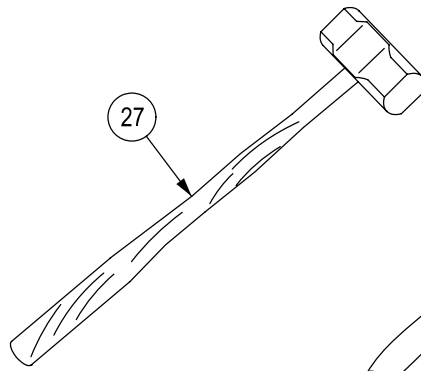
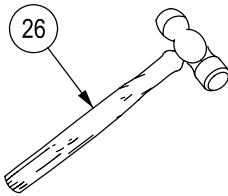
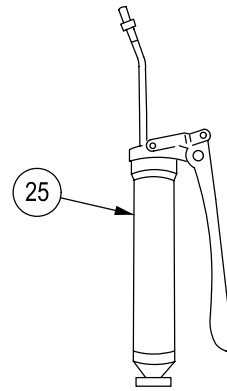
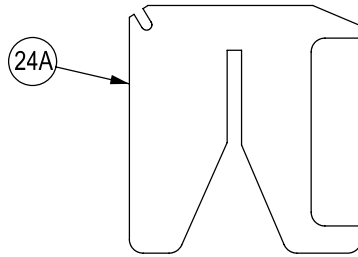
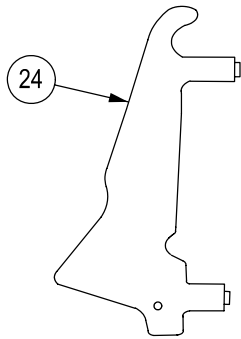

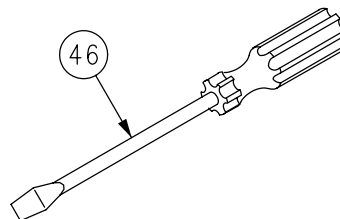
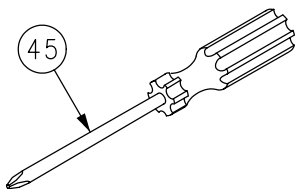
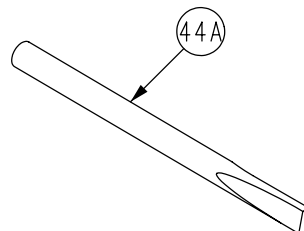
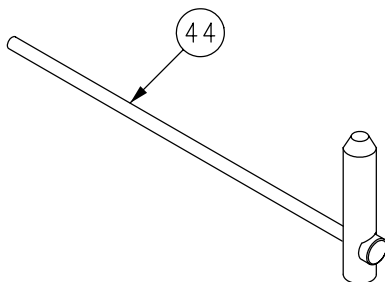
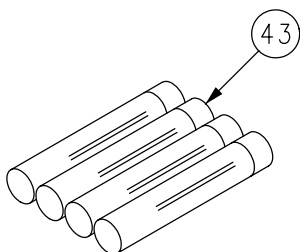
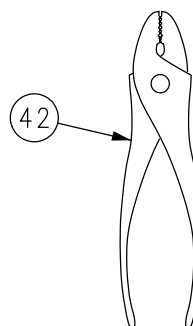
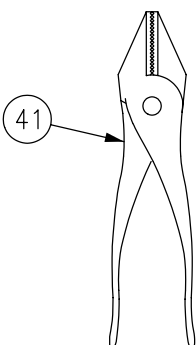
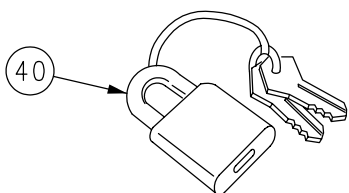
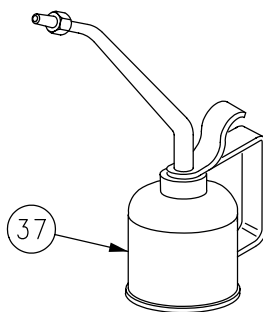
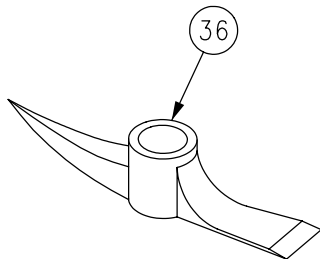
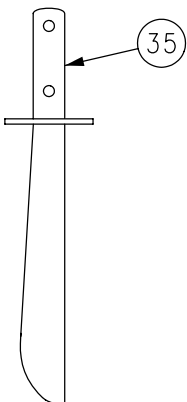

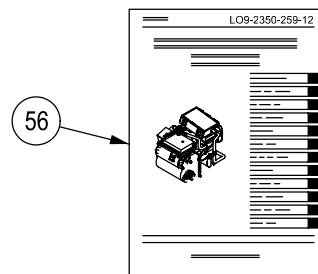
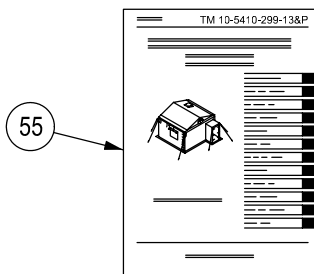
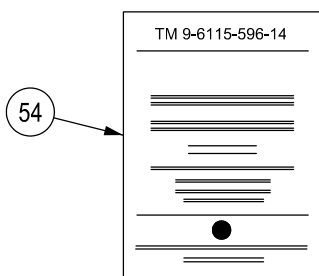
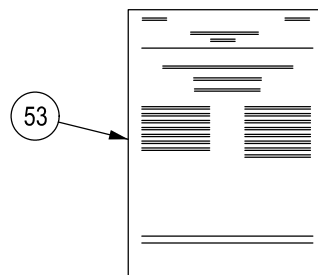
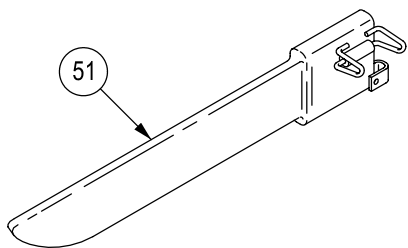
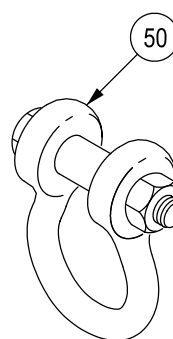
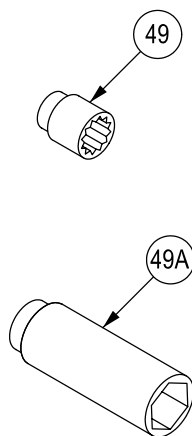
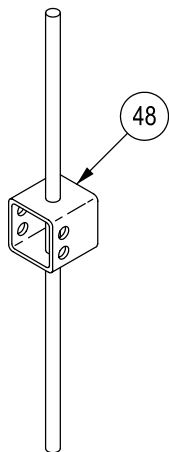
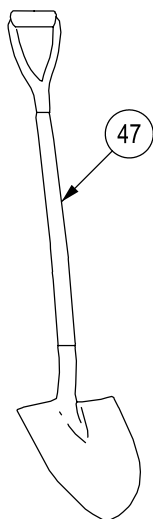

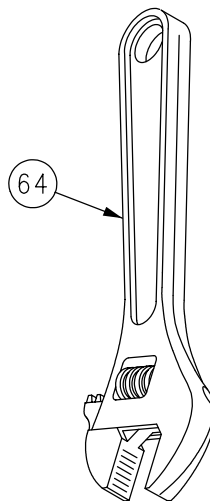
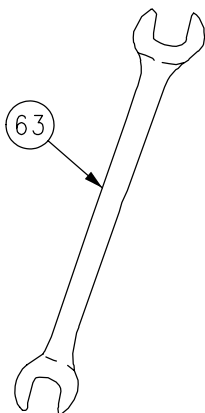
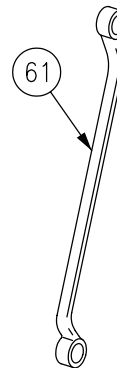
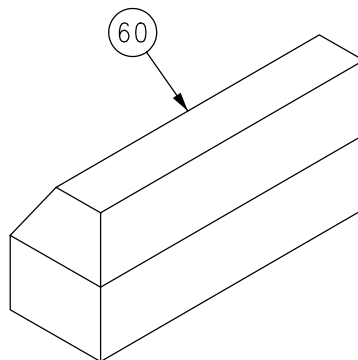
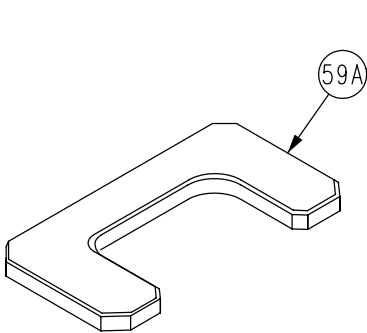
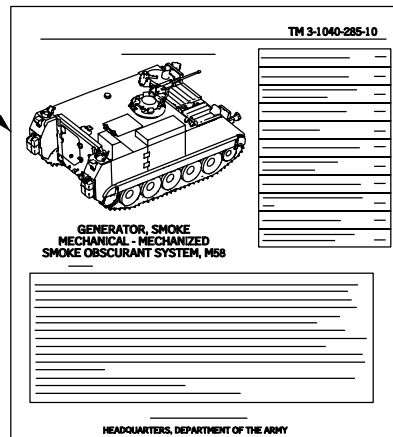
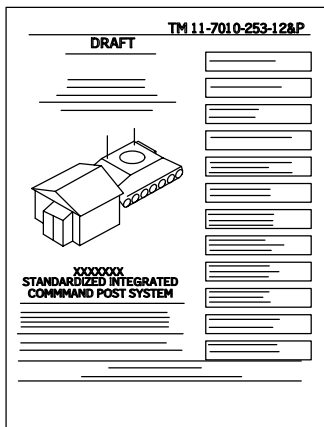

COMPONENTS OF END ITEM AND BASIC ISSUE ITEMS — Continued

0102 00

Table 2. Basic Issues Item (BII) List

(1) ILLUS NUMBER	(2) NATIONAL STOCK NUMBER	(3) DESCRIPTION, CAGEC, AND PART NUMBER	(4) USABLE ON CODE	(5) U/M	(6) QTY RQR
1	5120-00-144-5207	ADAPTER, SOCKET WRENCH, 3/4 IN. MALE END × 1/2 IN. FEMALE END, (IN TOOL BAG) (19207) 11655788-3	APC, AP6, AP5, AP3, AP2, AP8	EA	1
2	5110-00-293-2336	AXE, SINGLE BIT, 4 LB (ON TOP REAR DECK) (19207) 6150925	APC, AP6, AP5, AP3	EA	1
2	5110-00-293-2336	AXE, SINGLE BIT, 4 LB (ON TOP DECK RIGHT SIDE) (19207) 6150925	AP2	EA	1
2	5110-00-293-2336	AXE, SINGLE BIT, 4 LB (ON TOP DECK, REAR CENTER) (19207) 6150925	AP8	EA	1
3	2540-00-670-2459 OR	BAG, PAMPHLET (ON DRIVER'S POWER PLANT ACCESS PANEL) (GREEN) (19207) 7961712	APC, AP6	EA	1
3	2540-00-670-2459 OR	BAG, PAMPHLET (TAN) (19207) 7961712-1	APC, AP6	EA	1
3	2540-00-670-2459	BAG, PAMPHLET (WHITE) (19207) 7961712-2	APC, AP6	EA	1
3	2540-00-670-2459 OR	BAG, PAMPHLET (BEHIND DRIVER ON WALL) (GREEN) (19207) 7961712	AP5, AP3	EA	1
3	2540-00-670-2459 OR	BAG, PAMPHLET (TAN) (19207) 7961712-1	AP5, AP3	EA	1
3	2540-00-670-2459	BAG, PAMPHLET (WHITE) (19207) 7961712-2	AP5, AP3	EA	1
3	2540-00-670-2459 OR	BAG, PAMPHLET (ON POWER PLANT REAR PANEL) (GREEN) (19207) 7961712	AP2	EA	1
3	2540-00-670-2459 OR	BAG, PAMPHLET (TAN) (19207) 7961712-1	AP2	EA	1
3	2540-00-670-2459	BAG, PAMPHLET (WHITE) (19207) 7961712-2	AP2	EA	1
3	2540-00-670-2459 OR	BAG, PAMPHLET (ON LOWER REAR POWER PLANT ACCESS PANEL) (GREEN) (19207) 7961712	AP8	EA	1
3	2540-00-670-2459 OR	BAG, PAMPHLET (TAN) (19207) 7961712-1	AP8	EA	1
3	2540-00-670-2459	BAG, PAMPHLET (WHITE) (19207) 7961712-2	AP8	EA	1
4	8105-01-420-4178	BAG, TOOL CHAIN HOIST (ON RIGHT REAR SPONSON) FOR 4.2KW GENERATOR SET ONLY (19207) 12381815	AP5, AP3	EA	1

COMPONENTS OF END ITEM AND BASIC ISSUE ITEMS — Continued

0102 00

(1) ILLUS NUMBER	(2) NATIONAL STOCK NUMBER	(3) DESCRIPTION, CAGEC, AND PART NUMBER	(4) USABLE ON CODE	(5) U/M	(6) QTY RQR
5	5140-00-473-6256	BAG, TOOL (ON RIGHT SPONSON) (19207) 11655979	AP6, AP5, AP3	EA	1
5	5140-00-473-6256	BAG, TOOL (LEFT OF DRIVER ON SPONSON) (19207) 11655979	AP8	EA	1
5	5140-00-473-6256	BAG, TOOL (LEFT, REAR SPONSON) (19207) 11655979	APC	EA	1
6	7510-00-889-3494	BINDER, LOOSE LEAF (IN PAMPHLET BAG) (19207) 11677003	AP8	EA	1
7	4010-00-767-3149	CABLE, TOW (ON RAMP) (19207) 10861718	APC, AP6, AP5, AP3	EA	1
7	4010-00-767-3149	CABLE, TOW (ON RAMP, OUTSIDE) (19207) 10861718	AP2, AP8	EA	1
8	7240-01-506-4424	CAN, WATER (ON BACK OF CARRIER) (TAN) (81349) MIL-C-43613	APC, AP6, AP5, AP3	EA	1
8	7240-01-506-4424	CAN, WATER (ON LEFT REAR, OUTSIDE) (TAN) (81349) MIL-C-43613	AP2	EA	1
8	7240-01-506-4426	CAN, WATER (2 ON RIGHT EXTERNAL FUEL TANK, 1 ON LEFT EXTERNAL FUEL TANK) (GREEN) (81349) MIL-C-43613	AP8	EA	3
9	3950-00-889-8722	CHAIN HOIST (IN TOOL BAG 6) (19207) 12381800	AP5, AP3	EA	1
10		DELETED□			
11	1005-00-487-4100	COVER, .50 CALIBER MACHINE GUN (ON .50 CALIBER MACHINE GUN OR ON TOP OF BATTERY BOX) (19204) 11631791	APC, AP6, AP2	EA	1
11	1005-00-487-4100	COVER, .50 CALIBER MACHINE GUN (ON .50 CALIBER MACHINE GUN) (19204) 11631791	AP8	EA	1
12		DELETED□			
13	5120-00-240-6040	CROWBAR, PINCH (ON TOP REAR DECK) (19207) 11677049	APC, AP6, AP5, AP3	EA	1
13	5120-00-240-6040	CROWBAR, PINCH (ON TOP DECK, RIGHT) (19207) 11677049	AP2	EA	1
13	5120-00-240-6040	CROWBAR, PINCH (ON TOP DECK, REAR CENTER) (19207) 11677049	AP8	EA	1
14	2540-00-923-4250	CURTAIN, AIR GRILL (ON ENGINE BULKHEAD, UPPER RIGHT) (19207) 10950064	AP2	EA	1

COMPONENTS OF END ITEM AND BASIC ISSUE ITEMS — Continued

0102 00

(1) ILLUS NUMBER	(2) NATIONAL STOCK NUMBER	(3) DESCRIPTION, CAGEC, AND PART NUMBER	(4) USABLE ON CODE	(5) U/M	(6) QTY RQR
15	2590-00-953-2172	DAVIT (ON TOP DECK) FOR 4.2 KW GENERATOR SET APU ONLY (19207) 10917960	AP5, AP3	EA	1
16	7510-01-065-0166	FOLDER, EQUIPMENT RECORD (IN PAMPHLET BAG) (72094) 43986-1	APC, AP6, AP2, AP8, AP5, AP3	EA	1
17	5110-00-595-8229	CUTTER, WIRE, M1938 (IN TOOL BAG) (19207) 11655981	APC, AP6, AP5, AP3, AP2, AP8	EA	1
18	4930-00-288-1511	EXTENSION, ADAPTER, GREASE GUN (IN TOOL BAG) (19207) 6300333	APC, AP6, AP5, AP3, AP2, AP8	EA	1
19	5120-00-227-8074	EXTENSION, BAR, 1/2 IN. × 10 IN. (IN TOOL BAG) (19207) 11655788-1	APC, AP6, AP5, AP3, AP8	EA	1
19A	5120-00-473-6320	EXTENSION, WRENCH HANDLE (SECURED UNDER TOOL BAG) (55719) 36A	APC, AP6, AP5, AP3, AP2, AP8	EA	1
20	4210-00-270-4512 OR	EXTINGUISHER, FIRE, 5 LB (ON RIGHT REAR BULKHEAD) (19207) 7714780	APC, AP6	EA	1
20	4210-01-107-9912	EXTINGUISHER, FIRE, 5 LB (ON RIGHT REAR BULKHEAD) (19207) 7359703	APC, AP6	EA	1
20	4210-00-270-4521 OR	EXTINGUISHER, FIRE, 5 LB (ON RIGHT SIDE WALL) (19207) 7714780	AP3	EA	1
20	4210-01-107-9912	EXTINGUISHER, FIRE, 5 LB (ON RIGHT SIDE WALL) (19207) 7359703	AP3	EA	1
20	4210-00-270-4521 OR	EXTINGUISHER, FIRE, 5 LB (ON RIGHT REAR WALL) (19207) 7714780	AP5	EA	1
20	4210-01-107-9912	EXTINGUISHER, FIRE, 5 LB (ON RIGHT REAR WALL) (19207) 7359703	AP5	EA	1
20	4210-00-270-4512 OR	EXTINGUISHER, FIRE, 5 LB (ON LEFT REAR FUEL CELL WALL) (19207) 7714780	AP2	EA	1
20	4210-01-107-9912	EXTINGUISHER, FIRE, 5 LB (ON LEFT REAR FUEL CELL WALL) (19207) 7359703	AP2	EA	1
20	4210-00-270-4521 OR	EXTINGUISHER, FIRE, 5 LB (ON LEFT REAR WALL BETWEEN BATTERY BOX AND FOG OIL TANK) (19207) 7714780	AP8	EA	1
20	4210-01-107-9912	EXTINGUISHER, FIRE, 5 LB (ON LEFT REAR WALL BETWEEN BATTERY BOX AND FOG OIL TANK) (19207) 7359703	AP8	EA	1

COMPONENTS OF END ITEM AND BASIC ISSUE ITEMS — Continued

0102 00

(1) ILLUS NUMBER	(2) NATIONAL STOCK NUMBER	(3) DESCRIPTION, CAGEC, AND PART NUMBER	(4) USABLE ON CODE	(5) U/M	(6) QTY RQR
21	4210-01-251-6275	EXTINGUISHER, FIRE, PORTABLE, (ON TOP OF CARRIER)/(ON RIGHT MIDPOINT WALL) (19207) 12313974	AP6	EA	2
22	6545-00-922-1200	FIRST AID KIT (IN DRIVER'S COMPARTMENT) (19207) 11677011	APC, AP6	EA	1
22	6545-00-922-1200	FIRST AID KIT (ON SPONSON, LEFT OF DRIVER) (19207) 11677011	AP5, AP3, AP2, AP8	EA	1
23	5120-01-041-4624	FIXTURE, TRACK (ON TOP DECK, REAR) (19207) 12253183	APC, AP6, AP5, AP3, AP8	EA	2
23	5120-01-041-4624	FIXTURE, TRACK (ON TOP DECK, FRONT) (19207) 12253183	AP2	EA	2
24	5220-01-041-9920	GAUGE, TRACK TENSION, TRACK BUSHING, AND SPROCKET WEAR (T130) (IN TOOL BAG) (19207) 12253280	APC, AP6, AP2, AP8, AP5, AP3	EA	1
24A	5220-01-496-3692	GAUGE, TRACK TENSION AND SPROCKET WEAR (T150) (IN TOOL BAG) (19207) 12474849	APC, AP6, AP5, AP3, AP2, AP8	EA	1
25	4930-00-253-2478	GREASE GUN, HAND (IN TOOL BAG) (19207) 10915142	APC, AP6, AP2, AP8	EA	1
25	4930-01-022-4876	GREASE GUN, HAND (IN TOOL BAG) (19207) 10915142	AP5, AP3	EA	1
26	5120-00-061-8546	HAMMER, HAND, BALL PEEN, 2 LB (IN TOOL BAG) (19207) 11677028-3	APC, AP6, AP5, AP3, AP2, AP8	EA	1
26	5120-00-061-8546	HAMMER, HAND, BALL PEEN, 2 LB (IN TOOL BAG) (19207) BPN32A	AP8	EA	1
27	5120-00-265-7462	HAMMER, HAND, SLEDGE, 6 LB (ON TOP DECK, REAR CENTER) (19172) 41796	AP5, AP3	EA	1
28		DELETED			
29	5120-00-288-6574	HANDLE, MATTOCK PICK (ON TOP DECK, REAR) (19207) 11677021	APC, AP6, AP5, AP3	EA	1
29	5120-00-288-6574	HANDLE, MATTOCK PICK (ON TOP DECK, RIGHT SIDE) (19207) 11677021	AP2	EA	1
30	5120-00-236-7590	HANDLE, SOCKET WRENCH, 1/2 IN. DRIVE (IN TOOL BAG) (19207) 11655786-1	APC, AP6, AP3, AP5, AP2, AP8	EA	1
30A		HANDLE, SOCKET WRENCH, 3/4 IN. DRIVE (UNDER TOOL BAG) (19207) 12474920	APC, AP6, AP3, AP5, AP2, AP8	EA	1
31		DELETED			

COMPONENTS OF END ITEM AND BASIC ISSUE ITEMS — Continued

0102 00

(1) ILLUS NUMBER	(2) NATIONAL STOCK NUMBER	(3) DESCRIPTION, CAGEC, AND PART NUMBER	(4) USABLE ON CODE	(5) U/M	(6) QTY RQR
32		LUBRICATION ORDER (IN PAMPHLET BAG) LO 5-2805-203-12	AP5, AP3	EA	1
33		DELETED			
34		DELETED			
35	5110-00-813-1286	MACHETE (ON RIGHT PLATE, BEHIND CREW SEAT) 2-9-128GGG-M45	AP2	EA	1
36	5120-00-243-2395	MATTOCK, PICK TYPE (ON TOP DECK REAR) (19207) 11677022	APC, AP6, AP5, AP3	EA	1
36	5120-00-243-2395	MATTOCK, PICK TYPE (ON TOP DECK, LEFT SIDE) (19207) 11677022	AP2	EA	1
37	4930-00-262-8868	OILER, HAND PUMP TYPE (IN POWER PLANT COMPARTMENT, FRONT SLOPE LEFT SIDE) (19207) 6169931	APC, AP6	EA	1
37	4930-00-262-8868	OILER, HAND PUMP TYPE (IN POWER PLANT COMPARTMENT, LEFT SIDE) (19207) 6169931	AP5, AP3	EA	1
37	4930-00-262-8868	OILER, HAND PUMP TYPE (IN POWER PLANT COMPARTMENT) (19207) 6169931	AP2	EA	1
37	4930-00-262-8868	OILER, HAND PUMP TYPE (IN POWER PLANT COMPARTMENT, LOWER RIGHT SIDE) (19207) 6169931	AP8	EA	1
38		DELETED □			
39		DELETED □			
40	5340-00-682-1645	PADLOCK, KEY OPERATED (ON DRIVER'S HATCH) (96906) MS35647-6	APC, AP6, AP5, AP3, AP2	EA	1
40	5340-00-682-1508	PADLOCK, KEY OPERATED (ON DRIVER'S HATCH) (96906) MS35644-3	APC, AP6	EA	1
40	5340-00-682-1645 OR	PADLOCK, KEY OPERATED (ON DRIVER'S HATCH) (96906) MS35647-6	AP8	EA	1
40	5340-00-682-1508	PADLOCK, KEY OPERATED (ON DRIVER'S HATCH) (96906) MS35647-3	AP8	EA	1
41	5120-00-239-8251	PLIERS, LINEMANS, W/SIDE CUTTER (IN TOOL BAG) (95683) 41P1839	APC, AP6, AP8	EA	1
42	5120-00-223-7397	PLIERS, SLIPJOINT STRAIGHT NOSE W/CUTTER (IN TOOL BAG) (19207) 11655775-3	APC, AP6, AP5, AP3, AP2, AP7, AP1, AP8	EA	1

COMPONENTS OF END ITEM AND BASIC ISSUE ITEMS — Continued

0102 00

(1) ILLUS NUMBER	(2) NATIONAL STOCK NUMBER	(3) DESCRIPTION, CAGEC, AND PART NUMBER	(4) USABLE ON CODE	(5) U/M	(6) QTY RQR
43	2540-00-923-4249	POST, CURTAIN (IN POCKET OF CURTAIN) (19207) 10950078	AP2	EA	5
44	5120-01-006-8847	PUNCH, DRIVE PIN (IN TOOL BAG) (19207) 11678718	APC, AP6, AP5, AP3, AP2, AP8	EA	1
44A	5120-01-496-3689	REMOVER, END CONNECTOR (IN TOOL BAG) (19207) 12474798	APC, AP6, AP5, AP3, AP2, AP8	EA	1
45	5120-00-234-8913	SCREWDRIVER, CROSS TIP, NO. 2 (IN TOOL BAG) (19207) 11655777-12	APC, AP6, AP5, AP3, AP2	EA	1
45	5120-00-234-8913	SCREWDRIVER, CROSS TIP, NO. 2 (IN TOOL BAG) (19207) MS15224-5	AP8	EA	1
46	5120-00-278-1283	SCREWDRIVER, FLAT TIP (IN TOOL BAG) (19207) 11655777-11	APC, AP6, AP5, AP3, AP2, AP8	EA	1
47	5120-00-293-3336	SHOVEL, HAND (ON FRONT SLOPE) (19207) 11655784	APC, AP6, AP5, AP3, AP2	EA	1
47	5120-00-293-3336	SHOVEL, HAND (ON TOP DECK, FRONT CENTER) (19207) 11655784	AP8	EA	1
48	5120-01-233-1938	SOCKET (IN TOOL BAG) (81361) 31-15-2715	AP6	EA	1
49	5120-00-189-7932	SOCKET, WRENCH, 1/2 IN. × 9/16 IN. (IN TOOL BAG) (19207) 11677025-1	APC, AP6, AP5, AP3, AP2, AP8	EA	1
49	5120-00-189-7946	SOCKET, WRENCH, 1/2 IN. × 5/8 IN. (IN TOOL BAG) (19207) 11677025-2	APC, AP6, AP5, AP3, AP2, AP8	EA	1
49	5120-00-235-5870	SOCKET, WRENCH, 1/2 IN. × 11/16 IN. (IN TOOL BAG) (19207) 11677025-3	APC, AP6, AP5, AP3, AP2, AP8	EA	1
49	5120-00-189-7985	SOCKET, WRENCH, 1/2 IN. × 3/4 IN. (IN TOOL BAG) (19207) 11677025-4	APC, AP6, AP5, AP3, AP2, AP8	EA	1
49	5120-00-189-7934	SOCKET, WRENCH, 1/2 IN. × 7/8 IN. (IN TOOL BAG) (19207) 11677025-5	APC, AP6, AP5, AP3, AP2, AP8	EA	1
49	5120-00-189-7935	SOCKET, WRENCH, 1/2 IN. × 15/16 IN. (IN TOOL BAG) (19207) 11677025-6	APC, AP6, AP5, AP3, AP2, AP8	EA	1

COMPONENTS OF END ITEM AND BASIC ISSUE ITEMS — Continued

0102 00

(1) ILLUS NUMBER	(2) NATIONAL STOCK NUMBER	(3) DESCRIPTION, CAGEC, AND PART NUMBER	(4) USABLE ON CODE	(5) U/M	(6) QTY RQR
49A	5130-00-227-6681	SOCKET WRENCH, 1-1/8 IN. (IN TOOL BAG) (55719) IM 362	APC, AP6, AP5, AP3, AP2, AP8	EA	1
50	4030-01-369-7612	SHACKLE (IN TOOL BAG) (NOT REQUIRED IF VEHICLE HAS THE TWO NEW STYLE FRONT TOWING EYES) (19207) 12381884	APC, AP6, AP5, AP3, AP2, AP8	EA	2
51	8465-00-926-4932	SHEATH, MACHETE (ON MACHETE) (81349) MIL-S-2329	AP2	EA	1
52		TECHNICAL MANUAL (IN PAMPHLET BAG) TM 9-2350-277-10	APC, AP6, AP5, AP3	EA	1
53		TECHNICAL MANUAL (IN PAMPHLET BAG) TM 5-2805-203-14 (4.2 KW GENERATOR SET, ENGINE)	AP5, AP3	EA	1
54		TECHNICAL MANUAL (IN PAMPHLET BAG) TM 5-6115-596-14 (4.2 KW GENERATOR SET, GENERATOR)	AP5, AP3	EA	1
54		OR TECHNICAL MANUAL (IN PAMPHLET BAG) TM9-6115-664-13&P (5.0 KW AUXILIARY POWER UNIT, APU)	AP3	EA	1
55		TECHNICAL MANUAL (IN PAMPHLET BAG) TM 10-8340-243-13&P (MODULAR COMMAND POST SYSTEM)	AP3	EA	1
56		TECHNICAL MANUAL (IN PAMPHLET BAG) TM 11-5985-426-12&P (ANTENNA MAST)	AP3	EA	1
57		TECHNICAL MANUAL (IN PAMPHLET BAG) TM 11-7010-256-12&P (STANDARD INTEGRATED COMMAND POST SYSTEM)	AP3	EA	1
58		DELETED			
59		TECHNICAL MANUAL (OPERATOR'S) GENERATOR, SMOKE, MECHANICAL: MECHANIZED, SMOKE OBSCURANT SYSTEM, M58 (IN PAMPHLET BAG) TM 3-1040-285-10	AP8	EA	1
59A	5220-01-504-2610	TRACK PIN ALIGNMENT TOOL (IN TOOL BAG) (19207) 12474881	APC, AP2, AP3, AP5, AP6, AP8	EA	2

COMPONENTS OF END ITEM AND BASIC ISSUE ITEMS — Continued

0102 00

(1) ILLUS NUMBER	(2) NATIONAL STOCK NUMBER	(3) DESCRIPTION, CAGEC, AND PART NUMBER	(4) USABLE ON CODE	(5) U/M	(6) QTY RQR
60	9905-01-148-9546	WARNING DEVICE KIT: PORTABLE, TRIANGULAR-SHAPED WITH OPEN CENTER, 3 DEVICES PER SET, IN CONTAINER (TO RIGHT OF CARRIER COMMANDER) (19207) 11669000	AP8	EA	1
61	5120-00-224-3141	WRENCH, BOX, DOUBLE OFFSET, 5/8 × 11/16 IN. (IN TOOL BAG) (19207) 11655785-2	APC, AP6, AP5, AP3, AP2, AP8	EA	1
63	5120-00-277-2342	WRENCH, OPEN END, FIXED, 3/8 IN. × 7/16 IN. (IN TOOL BAG) (19207) 11655789-1	APC, AP6, AP5, AP3, AP2, AP8	EA	1
63	5120-00-187-7126	WRENCH, OPEN END, FIXED, 9/16 IN. × 5/8 IN. (IN TOOL BAG) (19207) 11655789-2	APC, AP6, AP5, AP3, AP2, AP8	EA	1
63	5120-00-277-8300	WRENCH, OPEN END, FIXED, 11/16 IN. × 13/16 IN. (IN TOOL BAG) (19207) 11655789-3	APC, AP6, AP5, AP3, AP2, AP8	EA	1
64	5120-00-264-3796	WRENCH, OPEN END, ADJUSTABLE, 1-5/16 IN. × 12 IN. (IN TOOL BAG) (19207) 11655778-5	APC, AP6, AP5, AP3, AP2, AP8	EA	1

ADDITIONAL AUTHORIZATION LIST (AAL)

0103 00

INTRODUCTION

Scope

This work package lists additional items you are authorized for the support of the M113A3 FOV carriers. AALs for subordinate systems are contained in the following TMs:

<u>System</u>	<u>TM</u>
M1064A43 4.7 inch, 120-mm, Mortar M121	TM 9-1015-250-10
M1068A3 Modular Post Command System (MCPS)	TM 10-8340-243-13&P
M1068A3 Standard Integrated Command Post System (SICPS)	TM 11-7010-256-12&P
M58 Smoke Obscure Systems	TM 3-1040-285-10

General

This list identifies items that do not have to accompany the M113A3 FOV carrier, and that do not have to be turned in with it. These items are all authorized to you by CTA, MTOE, TDA, or JTA.

Explanation of Columns in the AAL

- Column (1) — National Stock Number (NSN). Identifies the stock number of the item to be used for requisitioning purposes.
- Column (2) — Description, CAGEC, and Part Number. Identifies the Federal item name (in all capital letters) followed by a minimum description when needed. The last line below the description is the CAGEC (Commercial and Government Entity Code) (in parentheses) and the part number.
- Column (3) — Usable On Code. When applicable, gives you a code if the item you need is not the same for different models of equipment. These codes are identified below:

<u>Code</u>	<u>Used On</u>
APC	M113A3
AP2	M1064A3
AP3	M1068A3
AP5	M577A3
AP6	M1059A3
AP8	M58

- Column (4) — Unit of Measure (U/M). Indicates the physical measurement or count of the item as issued per the National Stock Number shown in column (1).
- Column (5) — Qty Recm. Indicates the quantity recommended.

Table 1. Additional Authorization List

(1) NATIONAL STOCK NUMBER	(2) DESCRIPTION, CAGEC, AND PART NUMBER	(3) USABLE ON CODE	(4) U/M	(5) QTY RECM
4930-00-204-2550	ADAPTER, GREASE GUN (36251) 5855		EA	1
5120-00-926-5175	BRUSH, CLEANING, BATTERY (36540) BT1		EA	1
5120-01-105-0779	COVER, GRILLE (19207) 12269299	APC, AP2, AP6, AP8	EA	1
2540-01-125-9653	COVER, GRILLE: (GREEN) (19207) 12269326	AP3, AP5	EA	1
2540-01-396-2473	COVER, GRILLE: (TAN) (19207) 12269326-T	AP3, AP5	EA	1
4230-01-133-4124	DECONTAMINATING APPARATUS, PORTABLE, M13 (81361) E5-51-527		EA	1
1331-01-020-0504	GRENADE, SMOKE SCREENING, RP, UK/L8A (K7312) TW74GF	APC, AP6, AP8	EA	12
4240-00-052-3776	GOGGLES, INDUSTRIAL (80204) ANSI Z87.1		PR	1
8465-01-328-8268	GOGGLES, SUN, WIND, AND DUST (99994) 43914		PR	1
5120-01-399-9254	HAMMER, HAND, 4 LB (ICV05) 1435G		EA	1
5120-00-265-7462	HAMMER, HAND, SLEDGE: 6 LB (90172) 41796		EA	1
1055-01-107-7501	LAUNCHER, GRENADE, AR (M259) (81361) B13-12-150	APC, AP2, AP6, AP8	EA	1
2590-01-107-9696	LIGHT, AMBER ROTATING WARNING (19207) 12296622	APC, AP2, AP6, AP8	EA	1
7240-00-255-8113	MEASURE, LIQUID, OIL CAN (1JZ80) 6110-007		EA	1
8340-00-841-6456	TARPAULIN, 12 FT X 17 FT, (GREEN) (81349) MIL-DTL-32063		EA	1
2540-01-330-8062	TARPAULIN, 12 FT X 17 FT, (TAN) (19207) 10936264-1T		EA	1
2540-00-936-7801	TOW BAR (M113A3 AND M1059A3) (19207) 11660660	APC, AP6	EA	1
5120-00-224-3154	WRENCH, BOX: 1/2 X 9/16 IN. (19207) 11655785-1		EA	1
5120-00-224-3141	WRENCH, BOX: 5/8 X 11/16 IN. (19207) 11655785-2	APC, AP2, AP6, AP8	EA	1
5120-00-935-4654	WRENCH, DRAIN PLUG (19207) 11595203	AP3, AP5	EA	1
5120-00-240-5609	WRENCH, OPEN END, FIXED: 3/4 X 7/8 IN. (19207) 11655789-4		EA	1
5120-00-277-7025	WRENCH, OPEN END, FIXED: 15/16 X 1 IN. (19207) 11655789-5		EA	1
5140-00-261-4994	CARRIER, WIRE CUTTER M1938 (19207) 11655787	AP3, AP5	EA	1
2510-01-105-0779	COVER GRILLE (GREEN) (19207) 12269299	AP3, AP5	EA	1

ADDITIONAL AUTHORIZATION LIST (AAL) — Continued

0103 00

(1) NATIONAL STOCK NUMBER	(2) DESCRIPTION, CAGEC, AND PART NUMBER	(3) USABLE ON CODE	(4) U/M	(5) QTY RECM
5340-01-486-5542	COVER ASSEMBLY, PROTECTIVE: (TAN) (19207) 12269299-1	AP3, AP5	EA	1
1080-00-108-1173	CAMOUFLAGE SCREENING SUPPORT SYSTEM (53119) 170212		EA	2
1080-01-457-2956	CAMOUFLAGE NET SYSTEM, RADAR (GREEN) (19397) 186310-0001		EA	1
	AMMUNITION:			
	CHEST, AMMUNITION (EMPTY)	AP2	EA	1
	BOX, AMMO, METAL, M2A1 (FOR CRTG .50 CAL LINKED, 105 RD CAP)		BOX	11
1305-00-926-3930	CARTRIDGE, CAL 5.56 MM, M196, C/CLIPS, MAGAZINE FILLERS, AND BANDOLIERS (FOR RIFLE M16A1/A2) 840 RD CANS (STOWED) (19200) 10523632		CAN	6
	ARMAMENT:			
1005-00-726-5636	MACHINE GUN, CAL.50, M2 (FLEX) (19204) 7265363	APC, AP2, AP6, AP8	EA	1
	EQUIPMENT, PARTS, AND TOOLS FOR MACHINE GUN M2:			
8105-00-921-5821	BAG, SMALL ARMS, ACCESSORIES (19204) 11686430	APC, AP2, AP6, AP8	EA	1
1005-00-726-6131	BARREL, SPARE, MACHINE GUN, CAL .50 (19204) 7266131	APC, AP2, AP6, AP8	EA	1
1005-00-322-9716	MOUNT, TRIPOD, MACHINE GUN (19204) 8403398	APC, AP2, AP6, AP8	EA	1
8415-01-092-0039	MITTEN, HEAT PROTECTIVE (81349) MIL-M-11199F	APC, AP2, AP6, AP8	EA	1
	COMMUNICATIONS EQUIPMENT			
3895-00-498-8343	REELING MACHINE, CABLE, HAND (80063) SM-D-333571	AP8	EA	1
	HELMET, CVC		EA	3
8415-00-094-2679	SMALL (GREEN)			
8415-00-094-2691	MEDIUM (GREEN)			
8415-00-094-2684	LARGE (GREEN)			
	OR			
	HELMET, COMBAT		EA	3
8470-01-130-8180	SMALL (GREEN) (81349) MIL-H-4417			

ADDITIONAL AUTHORIZATION LIST (AAL) — Continued

0103 00

(1) NATIONAL STOCK NUMBER	(2) DESCRIPTION, CAGEC, AND PART NUMBER	(3) USABLE ON CODE	(4) U/M	(5) QTY RECM
8470-01-130-3794	MEDIUM (GREEN) (81349) MIL-H-4417M			
8470-01-130-3795	LARGE (GREEN) (81349) MIL-H-4417L			
	MISCELLANEOUS EQUIPMENT:			
1240-01-207-5787	BINOCULAR, M22 (IN CASE) (19200) 12599242		EA	1
5855-00-150-1820	GOGGLES, NIGHT VISION, AN/PVS-5 (IN CASE) (31550) 8112270G1		EA	1
8970-01-297-2895	MEAL, READY-TO-EAT (81349) MIL-M-44074		BX	3
5855-00-629-5334	SIGHT, NIGHT VISION, INDIV WPN, AN/PVS-4 (80063) SMD850300-1		EA	3
6230-00-264-8261	FLASHLIGHT, ELECT., HAND, 2-CELL (21108) MX-991/U		EA	1
2540-01-458-4846	PARTS KIT, PINTLE HOOK (19207) 57K3383	APC, AP2, AP6, AP8	EA	1

EXPENDABLE/DURABLE SUPPLIES AND MATERIALS LIST

0104 00

INTRODUCTION

Scope

This work package lists expendable and durable items that you will need to operate and maintain the M113A3 FOV carriers. This list is for information only and is not an authority to requisition the listed items. These items are authorized to you by CTA 50-970, Expendable/Durable Items (Except Medical Class V, Repair Parts, and Heraldic Items) or CTA 8-100, Army Medical Department Expendable/Durable Items.

EXPLANATION OF COLUMNS

Column (1) — Item Number. This number is assigned to the entry in the list, and is referenced in the narrative instructions to identify the item (e.g. “Use cleaning compound (WP 0104 00, Item 6)”).

Column (2) — Level. This column identifies the lowest level of maintenance that requires the listed item.
C = Operator/Crew

Column (3) — National Stock Number (NSN). This is the NSN assigned to the item which you can use to requisition it.

Column (4) — Item Name, Description, Commercial and Government Entity Code (CAGEC), and Part Number. This column provides the other information you need to identify the item.

Column (5) — Unit of Measure (U/M). This code shows the physical measurement or count of an item, such as gallon (GL), pound (LB), dozen (DZ), etc.

Table 1. Expendable and Durable Items List

(1) ITEM NUMBER	(2) LEVEL	(3) NATIONAL STOCK NUMBER	(4) ITEM NAME, DESCRIPTION, CAGEC, PART NUMBER	(5) U/M
1			DELETED	
2			DELETED	
3			DELETED	
4			DELETED	
5	C	6859-00-224-6657	CLEANING COMPOUND, SOLVENT (FOR BORE OF SMALL ARMS AND AUTOMATIC WEAPONS) (81349) MIL-C-372	OZ
6	C	6850-01-277-0595	CLEANING COMPOUND (59557) 134H1-SOLV	GL
7	C	8305-00-267-3015	CLOTH, CHEESECLOTH, COTTON, BLEACHED AND UNBLEACHED: (81348) CCC-C-440, Type II, CLASS 2	LB
8	C	7930-00-282-9699	DETERGENT (81349) MIL-D-16791	GL
9	C	6230-00-264-8261	FLASHLIGHT, ELECTRIC: HAND, 2-CELL, MX 991U	EA
10	C	9150-01-197-7689	GREASE, (GAA), AUTOMOTIVE AND ARTILLERY (81349) MIL-G-10924	LB
10.1	C	9150-00-530-6814	GREASE, WIRE ROPE EXPOSED GEAR (81349) MIL-PRF-18458	QT
10.2	C	9150-00-111-6256	HYDRAULIC FLUID, FIRE RESISTANT (81349) MIL-PRF-46170	QT
11			DELETED	

EXPENDABLE/DURABLE SUPPLIES AND MATERIALS LIST — Continued

0104 00

(1) ITEM NUMBER	(2) LEVEL	(3) NATIONAL STOCK NUMBER	(4) ITEM NAME, DESCRIPTION, CAGEC, PART NUMBER	(5) U/M
11.1	C	9150-00-186-6681	LUBRICATING OIL, ENGINE (81349) MIL-PRF-2104	QT
11.2	C	9150-00-231-2361	LUBRICATING OIL, GENERAL PURPOSE (81349) MIL-PRF-3150	QT
11.3	C	9150-01-035-5390	LUBRICATING OIL, GEAR (81349) MIL-PRF-2105	QT
12			DELETED	
13			DELETED	
14	C	6640-00-285-4694	TISSUE, LENS (81348) NNN-P-40	SH
15	C	7920-00-205-1711	RAG, WIPING, COTTON AND COTTON SYNTHETIC (81348) DDD-R-30, GRADE B, (58536) A-A-531	LB
16	C	7930-00-880-4454	SOLUTION, LENS CLEANING (81348) P-D-410	GL
17			DELETED	
18			DELETED	

STOWAGE AND SIGN GUIDE

0105 00**SCOPE**

This work package shows the location of stowage of equipment and materiel required to be carried on the M113A3, M577A3, M1068A3, M1064A3, M1059A3, and M58 carriers.

GENERAL

The pictures on the following pages show where the equipment is stowed, and the decals, stencils, and straps at each position. Numbered callout pictures are for strap keys.

WARNING



Ammunition can explode and kill you. Make certain ammunition and all other combustible/explosive materials are properly stored 30 inches or more from heater vents. Combustible materials must be stored 12 inches or more from metal surfaces of the heater.

NOTE

You can stow either 5.56 mm ammunition or 7.62 mm ammunition in storage spaces that have decals for 7.62 mm ammunition.

STOWAGE GUIDE - M113A3 ARMORED PERSONNEL CARRIER DATAPLATE AND MARKER LOCATIONS

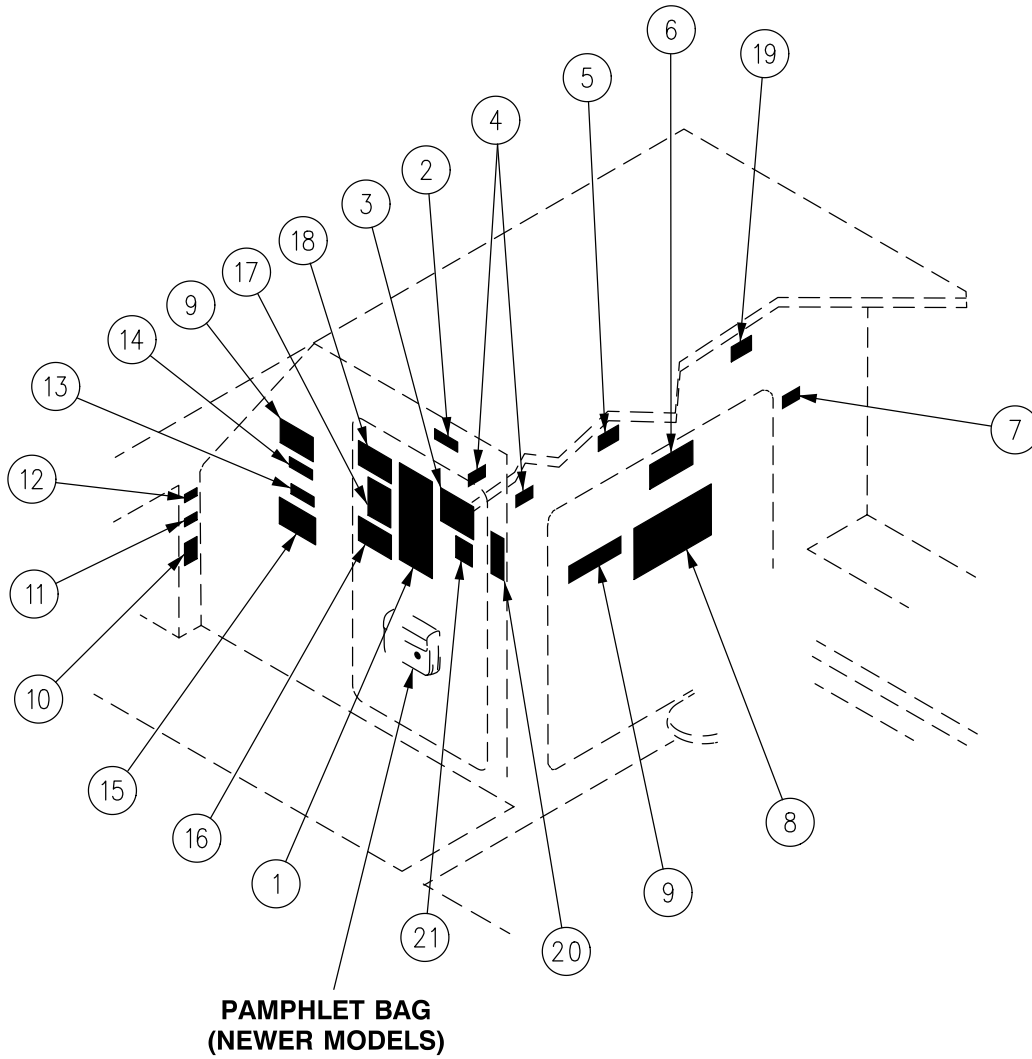

1. Marker, instruction, vehicle operation
2. Marker, WARNING, ramp lock
3. Marker, instruction, power train maintenance
4. Marker, instruction, ramp lock
5. Marker, WARNING, mortar alignment
6. Marker, WARNING, water operation
7. Marker, WARNING, personnel/equipment heater
8. Decal, WARNING, carbon monoxide (LARGE)
9. Decal, WARNING, pivot steer
10. Marker, engine idling
11. Marker, throttle
12. Decal, fuel shutoff
13. Marker, instruction, ramp actuating lever
14. Marker, WARNING, stall check
15. Plate, identification, vehicle
16. Plate, identification, vehicle shipping data
17. Marker, instruction, ramp operation
18. Marker, instruction, speed shift limit
19. Marker, identification, carc paint
20. Marker, WARNING, exhaust gas
21. Marker, CAUTION, noise

STOWAGE GUIDE - M113A3 ARMORED PERSONNEL CARRIER MARKER AND DECAL LOCATIONS

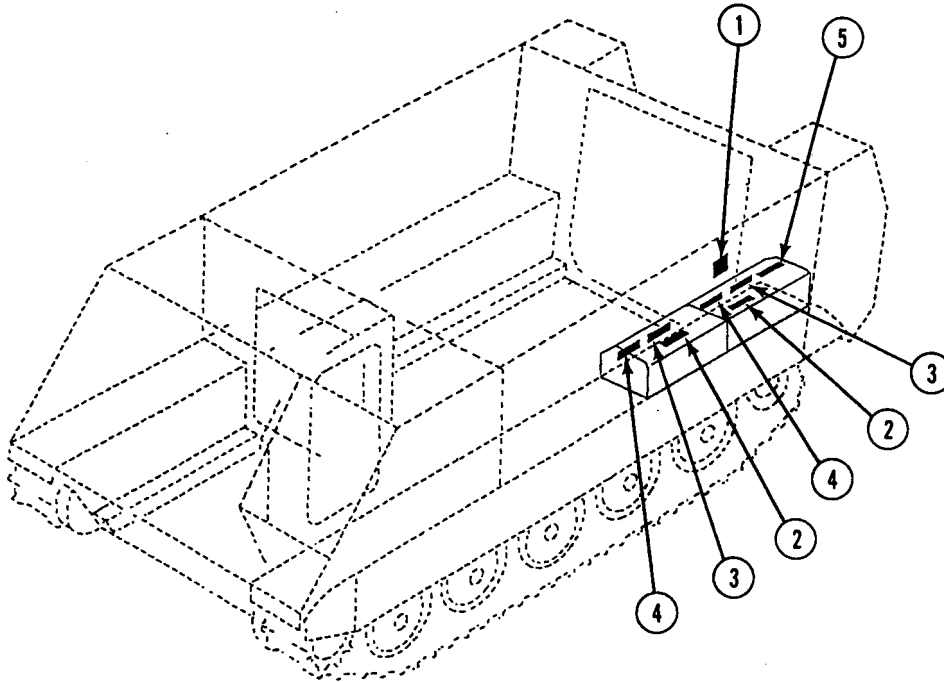

1. Marker, CAUTION, fuel supply and return (on spill liner)
2. Marker, instruction, battery service
3. Marker, WARNING, battery gas
4. Marker, WARNING, battery acid
5. Decal, tool bag

STOWAGE GUIDE - M113A3 ARMORED PERSONNEL CARRIER STENCIL LOCATIONS

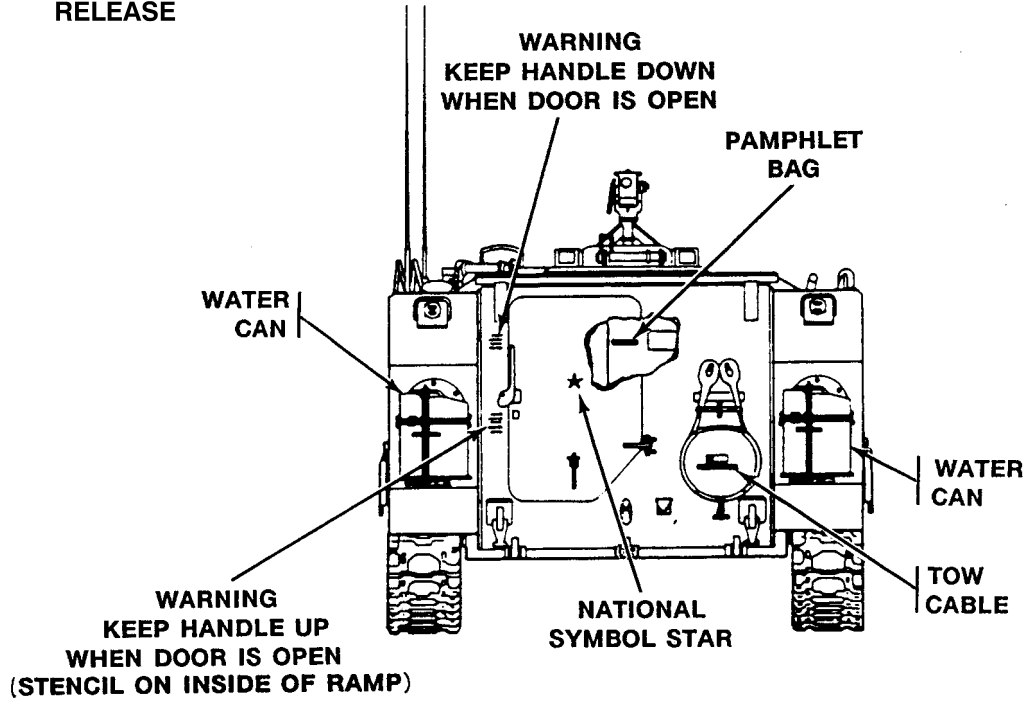
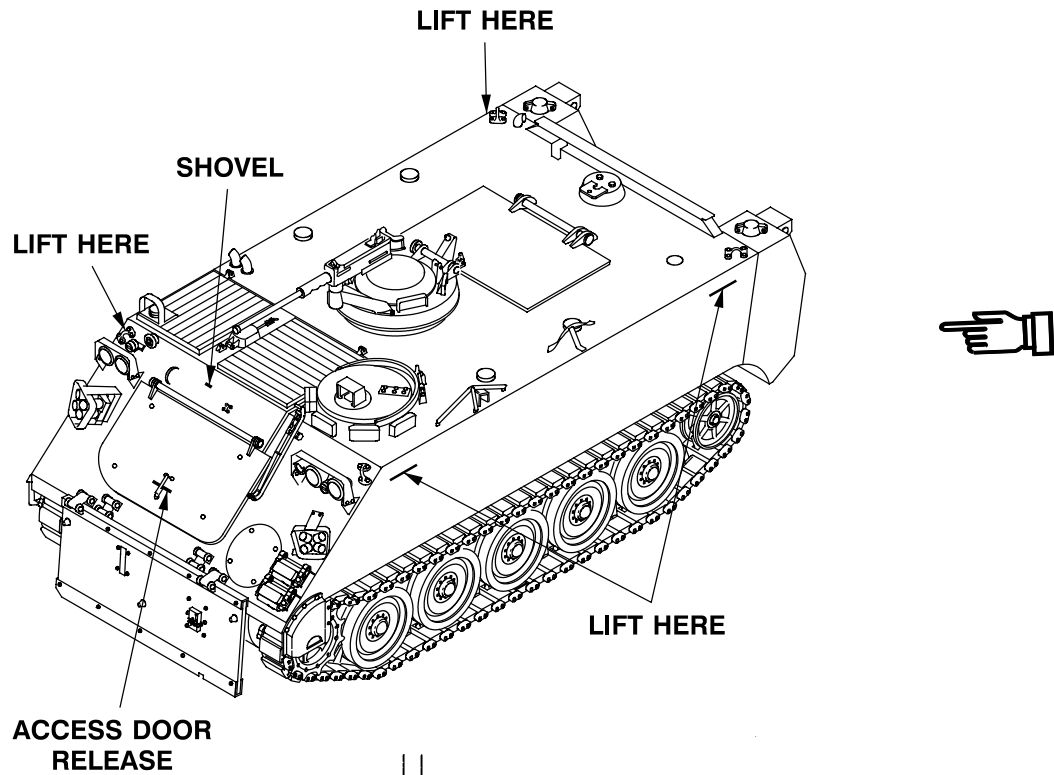

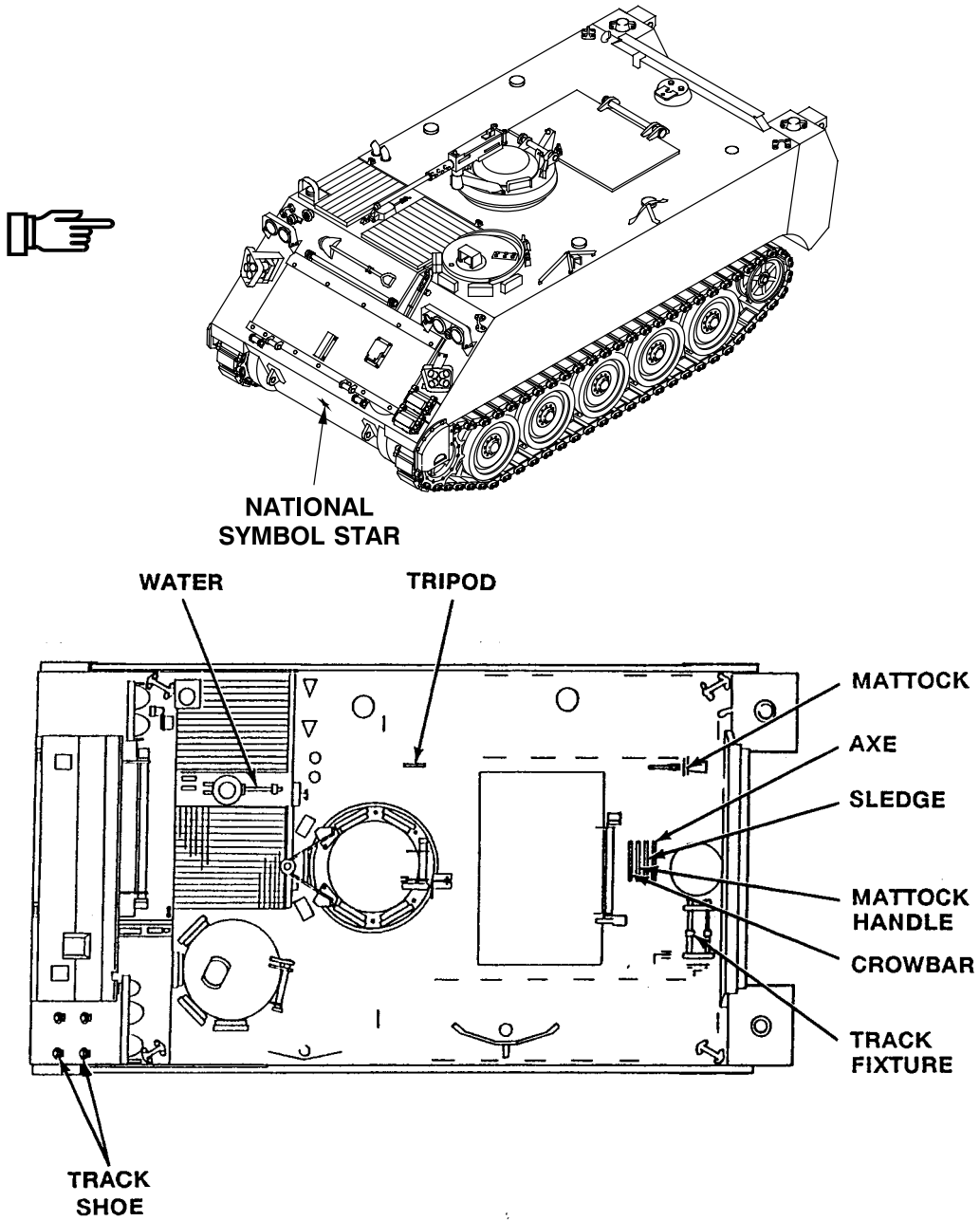

STOWAGE GUIDE - M113A3 ARMORED PERSONNEL CARRIER DECALS AND STENCILS

NOTE

Signs outlined with boxes are decals applied in locations shown. Signs not outlined with boxes are stencils.

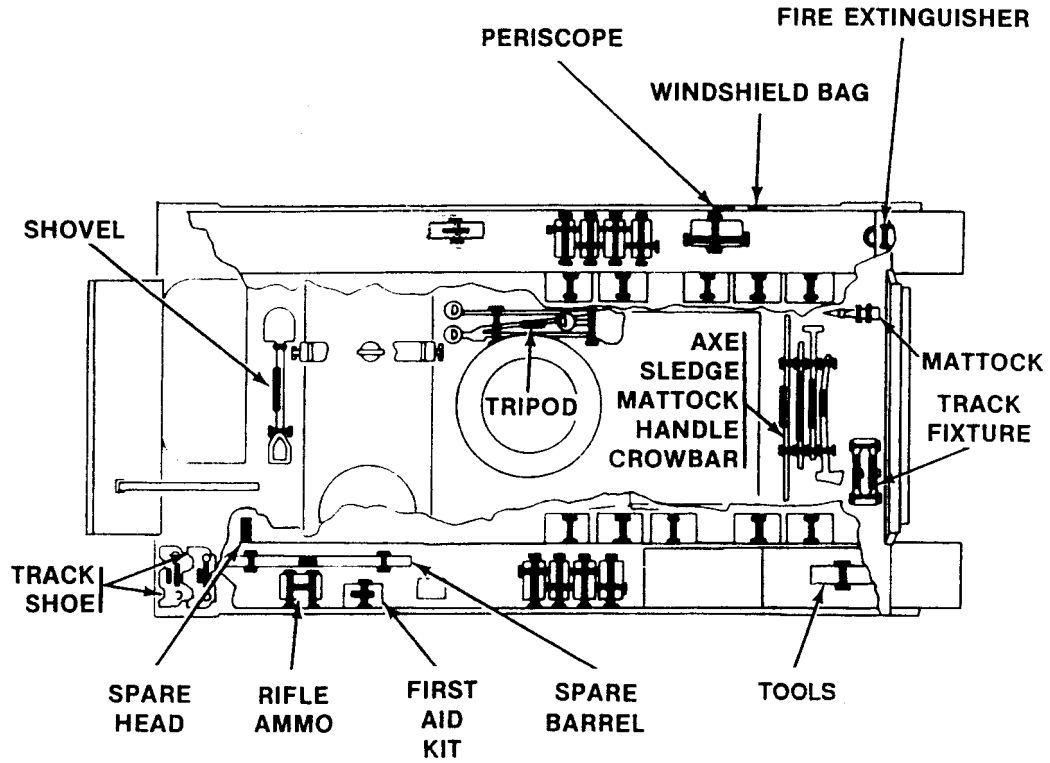

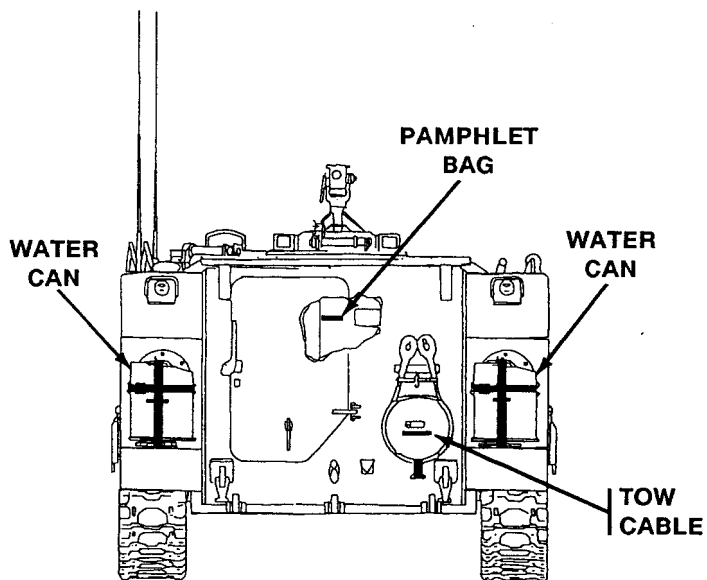
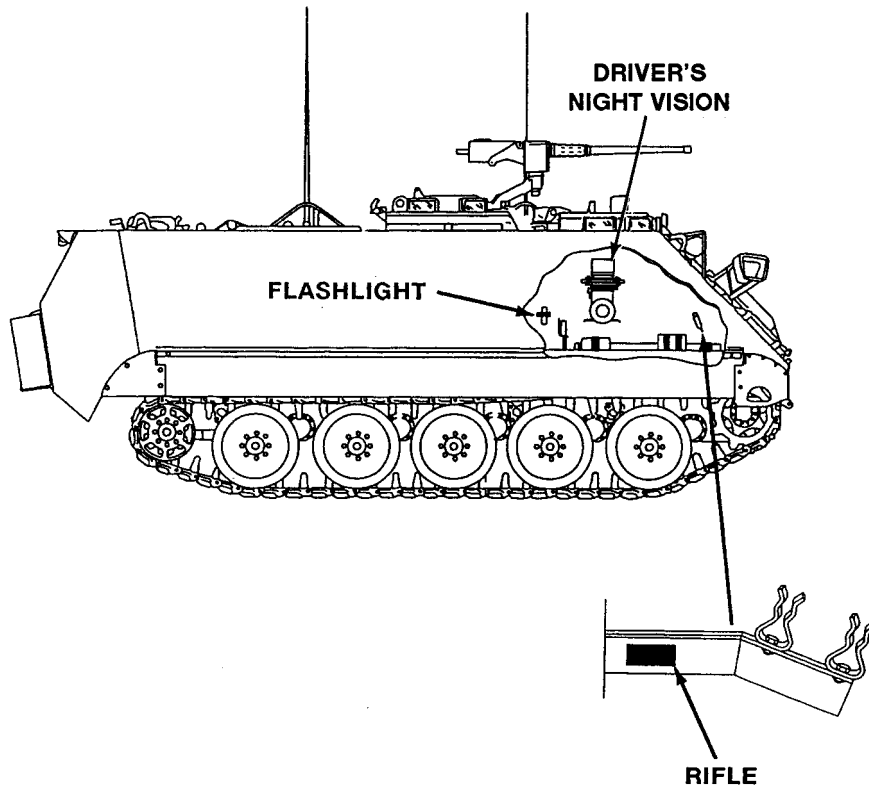

STOWAGE GUIDE - M113A3 ARMORED PERSONNEL CARRIER STRAPPING DIAGRAM

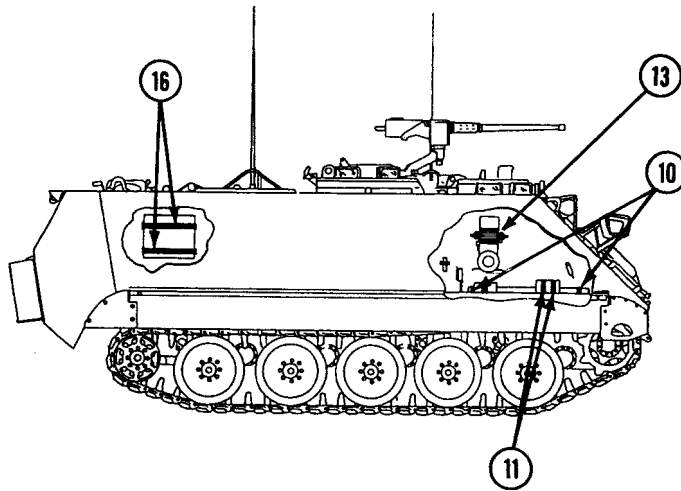
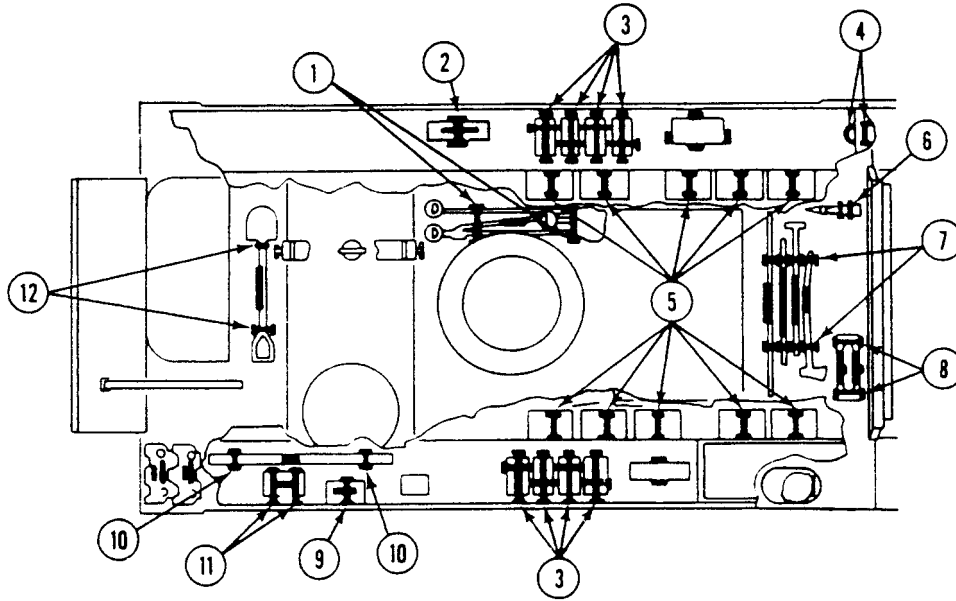

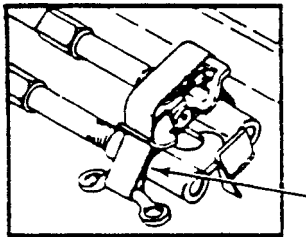
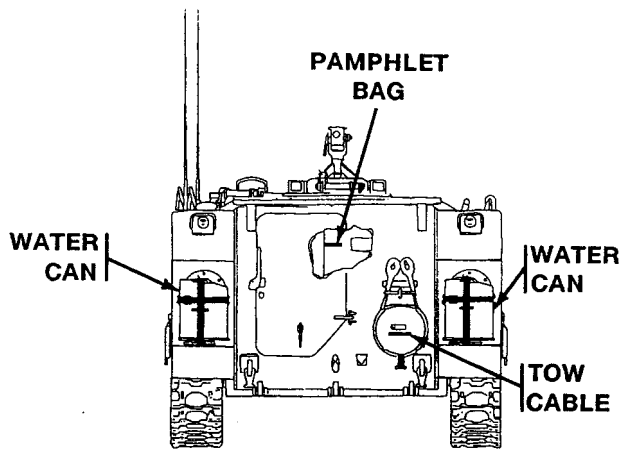

**PROPER METHOD OF STRAPPING.
MAKE CERTAIN BOTH LOOPS PASS
OVER TOP OF SECURED ITEM.**

STRAP KEY			
NO.	ITEM	QUANTITY	LENGTH (INCHES)
1	Tripod	2	36
2	Tool bag	1	48
3	Ammunition box, caliber .50	Suggested use only, no straps furnished	
4	Fire extinguisher	2	24
5	Miscellaneous stowage	10	39
6	Mattock	1	24
7	Pioneer tools	2	36
8	Track fixture	2	28
9	First aid kit	1	24
10	Spare barrel, caliber .50	2	24
11	Ammunition cases, rifle	2	45
12	Shovel	2	33, 20
13	Drivers night vision viewer AN/VVS-2	1	24
14	MOGAS, M13 decon or water cans	6	72, 88, 108
15	Tow cable	2	18, 30
16	Driver's windshield bag	2	68

STOWAGE GUIDE - M577A3 COMMAND POST CARRIER DATAPLATE AND MARKER LOCATIONS

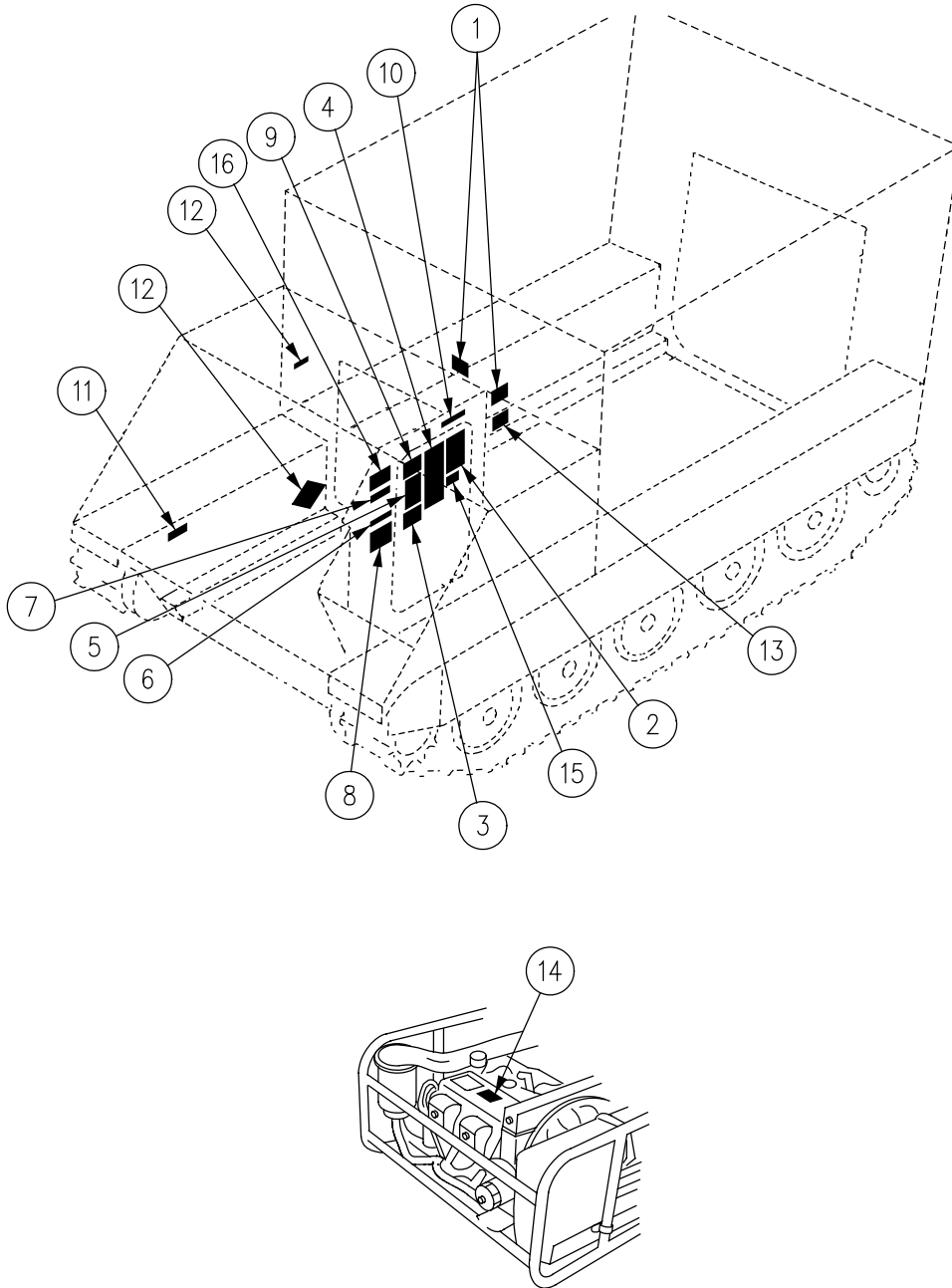

1. Marker, WARNING, ramp lock
2. Marker, instruction, power train maintenance
3. Marker, identification, vehicle shipping data
4. Marker instruction, vehicle operation
5. Marker, instruction, ramp
6. Marker, instruction, ramp actuating lever
7. Marker, WARNING, stall check
8. Plate, identification, vehicle
9. Marker, instruction, speed shift limit
10. Marker, instruction, ramp lock lever
11. Plate, instruction, engine air cleaner
12. Plate, warranty information
13. Marker, identification, carc paint
14. Marker, WARNING, NBC generator set, air cleaner
15. Marker, WARNING, noise
16. Decal, WARNING, pivot steer

STOWAGE GUIDE - M577A3 ARMORED PERSONNEL CARRIER MARKER AND DECAL LOCATIONS

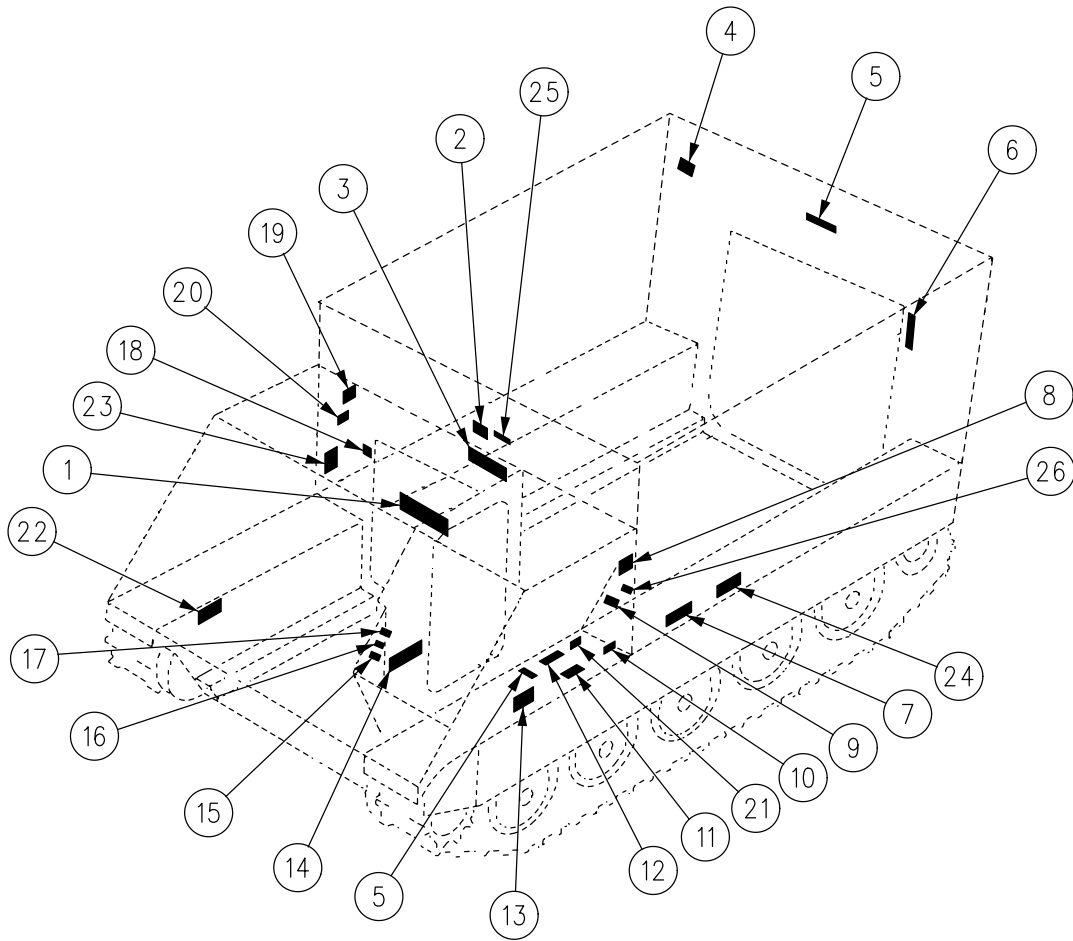

1. Decal, WARNING, carbon monoxide (LARGE)
2. Decal, CAUTION, hearing
3. Decal, WARNING, carbon monoxide (SMALL)
4. Decal, fire extinguisher
5. Decal, rifle
6. Decal, wall switch
7. Decal, tools
8. Decal, CAUTION, fire extinguisher safety wire
9. Decal, pamphlet bag
10. Decal flashlight
11. Decal, first aid kit
12. Decal, 5.56 ammunition
13. Decal, CAUTION, master switch
14. Decal, CAUTION, pivot steer
15. Marker, engine idling
16. Marker, throttle
17. Decal, fuel shutoff
18. Marker, WARNING, personnel/equipment heater
19. Marker, WARNING, blowtorch
20. Decal, blowtorch
21. Decal, spare head
22. Decal, WARNING, NBC, engine air cleaner
23. Decal, identification, fan oil gauge and fill
24. Decal, chain hoist and bag
25. Marker, WARNING, ramp lock
26. Marker, NBC

STOWAGE GUIDE - M577A3 COMMAND POST CARRIER DECALS

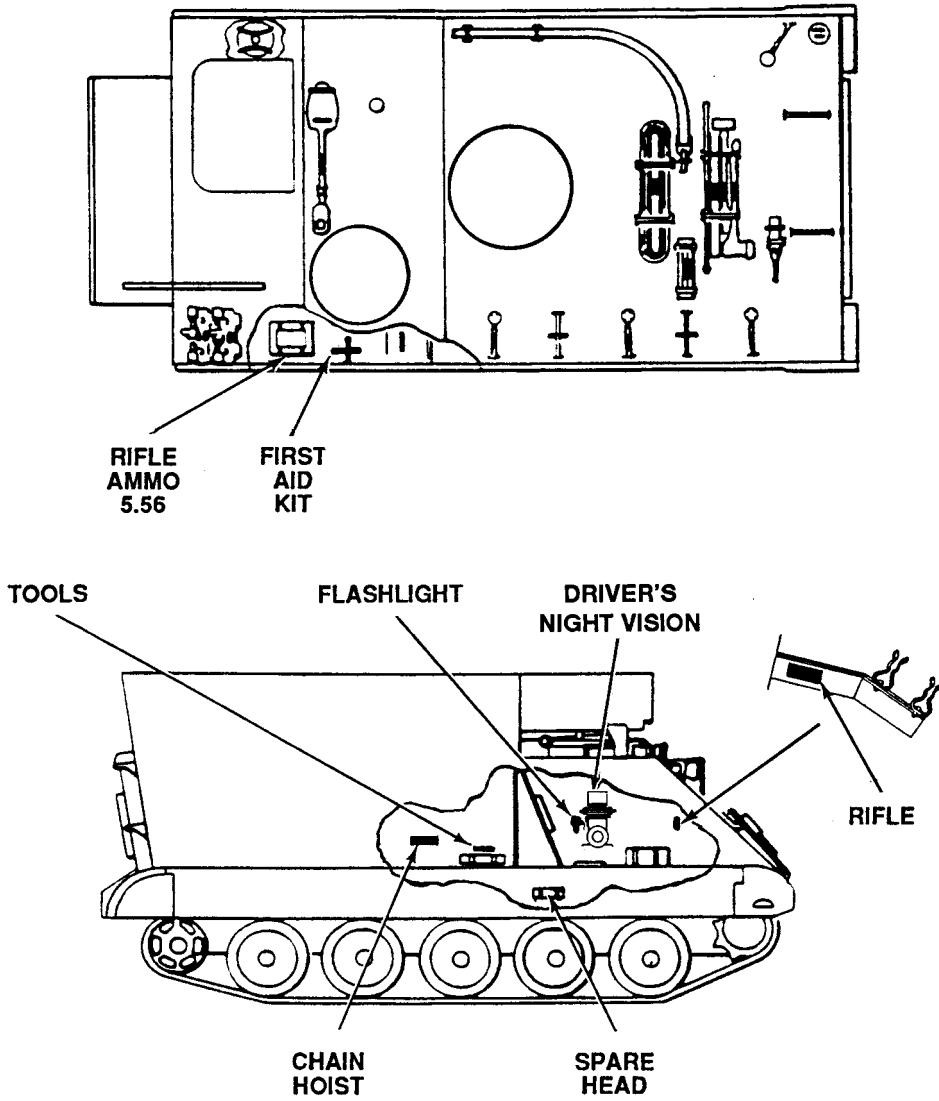

STOWAGE GUIDE - M577A3 COMMAND POST CARRIER STENCIL LOCATIONS

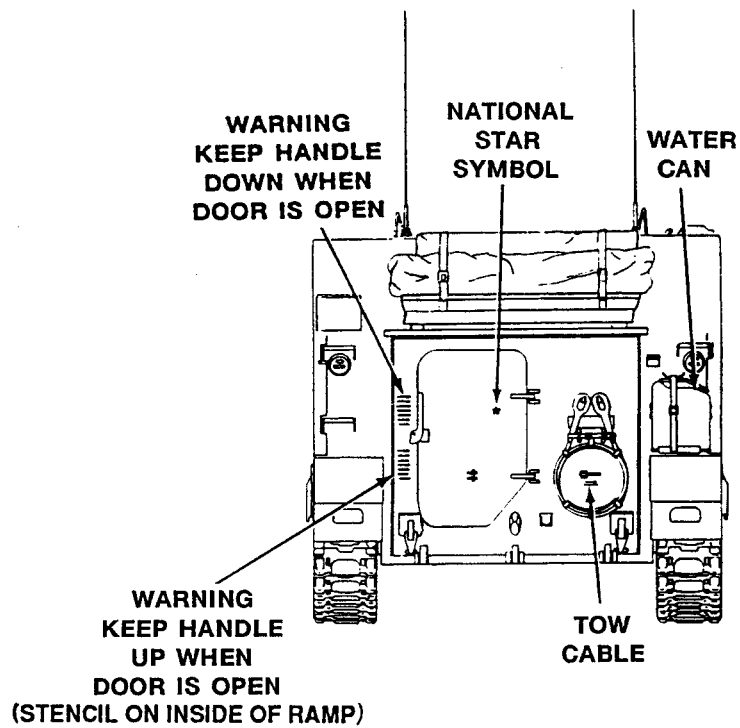
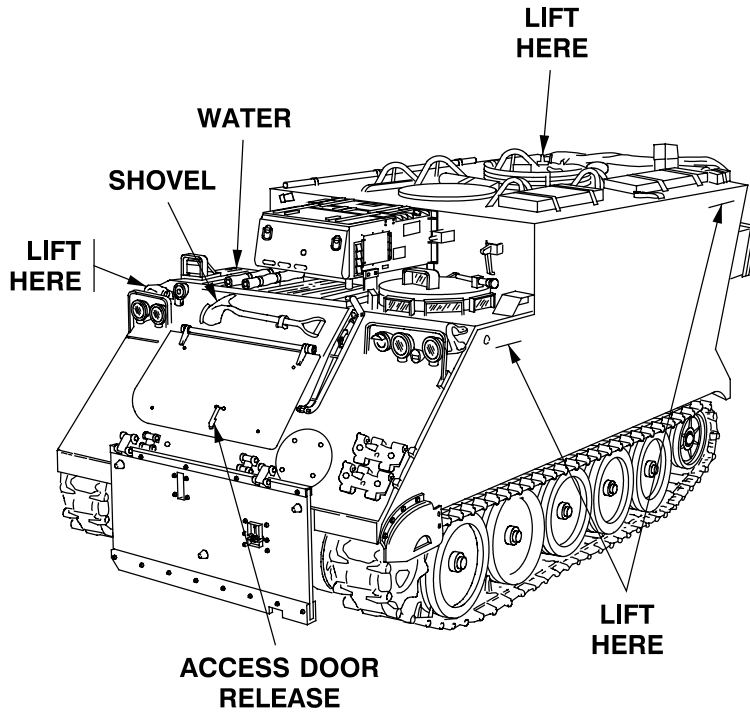

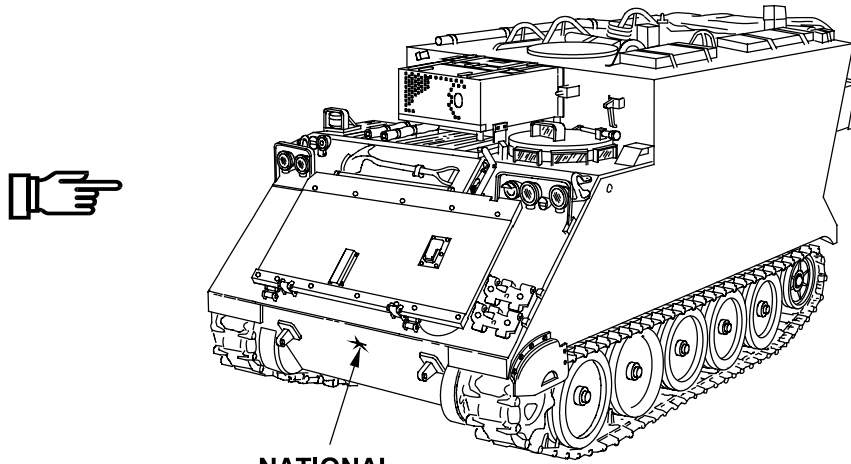

NATIONAL
SYMBOL STAR

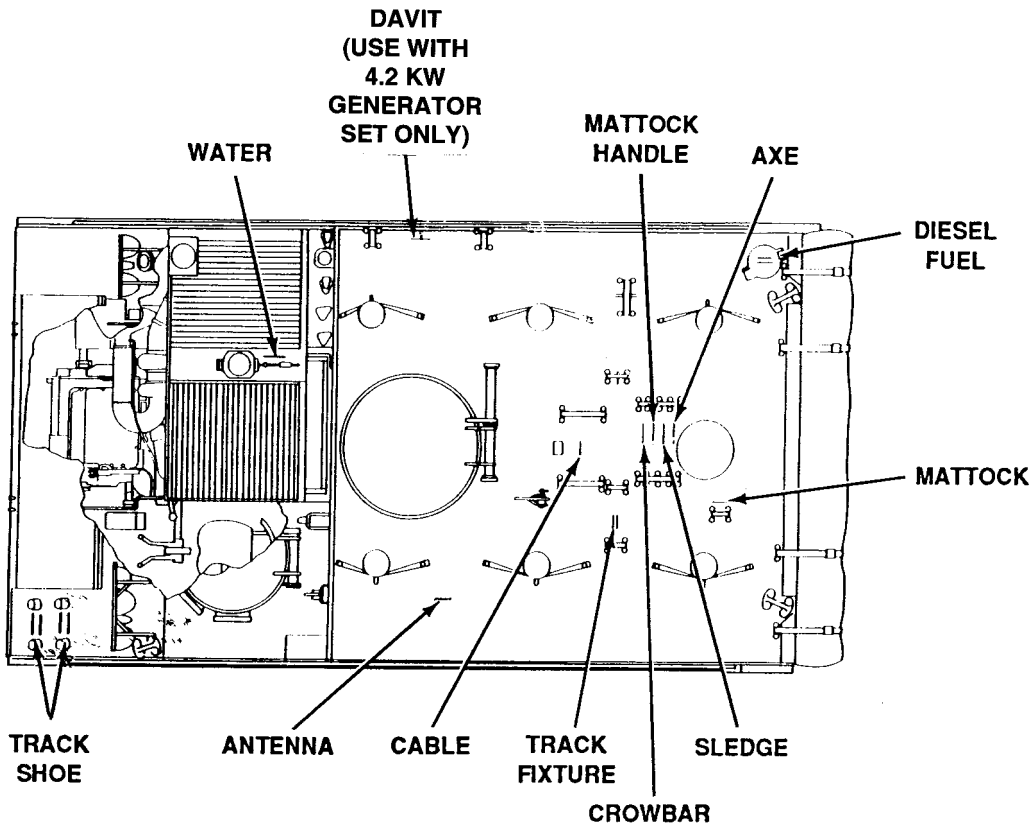

STOWAGE GUIDE - M577A3 COMMAND POST CARRIER STRAPPING DIAGRAM

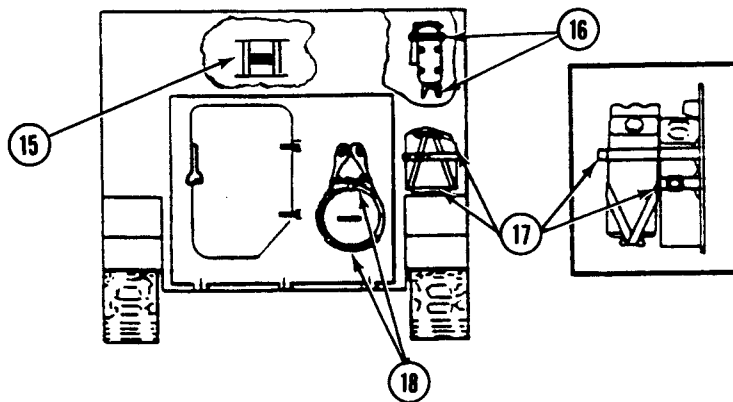
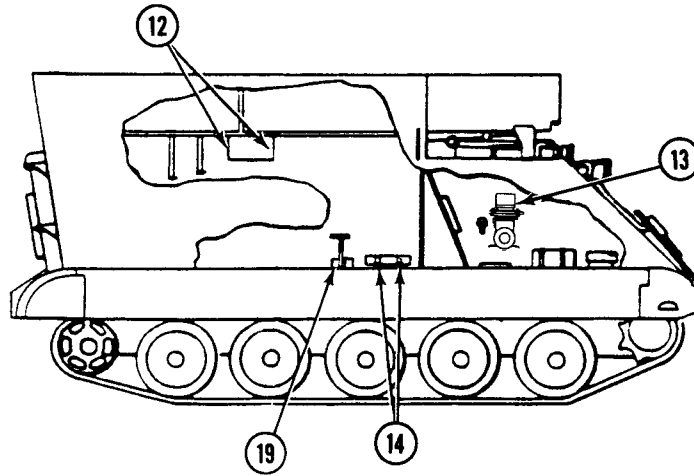
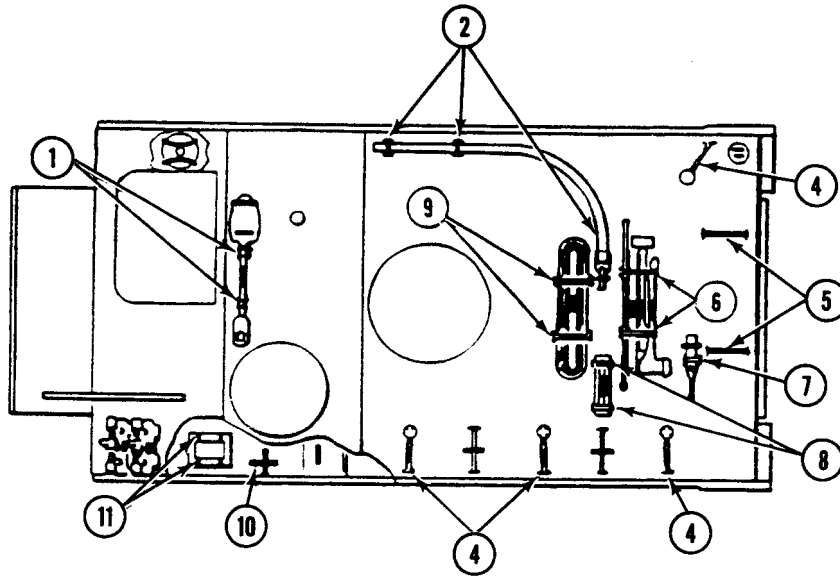

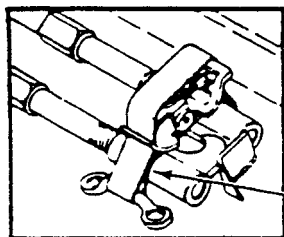

**PROPER METHOD OF STRAPPING.
MAKE CERTAIN BOTH LOOPS PASS
OVER TOP OF SECURED ITEM.**

STRAP KEY			
NO.	ITEM	QUANTITY	LENGTH (INCHES)
1	Shovel	2	33, 20
2	Davit (for 4.2 KW generator set only)	3	22
3	Chain hoist and bag	1	30
4	Duffle bag/field pack	4	72, 96
5	Duffle bag/field pack	2	72
6	Pioneer tools	2	36
7	Mattock	1	36
8	Track fixture	2	28
9	Nato slave cable	2	36
10	First aid kit	1	24
11	Ammunition cases, rifle 5.56	2	45
12	Radio	2	45
13	Driver's night vision viewer AN/VVS-2	1	24
14	Tool bag	2	36
15	Driver's windshield bag	2	68
16	Fire extinguisher	2	24
17	Water can or M13 decon can	3	72, 88, 108
18	Tow cable	2	18, 30
19	Chain hoist and bag (for 4.2 KW generator set only)	1	36

STOWAGE GUIDE - M1068A3 STANDARD INTEGRATED COMMAND POST SYSTEM DATAPLATE AND MARKER LOCATIONS

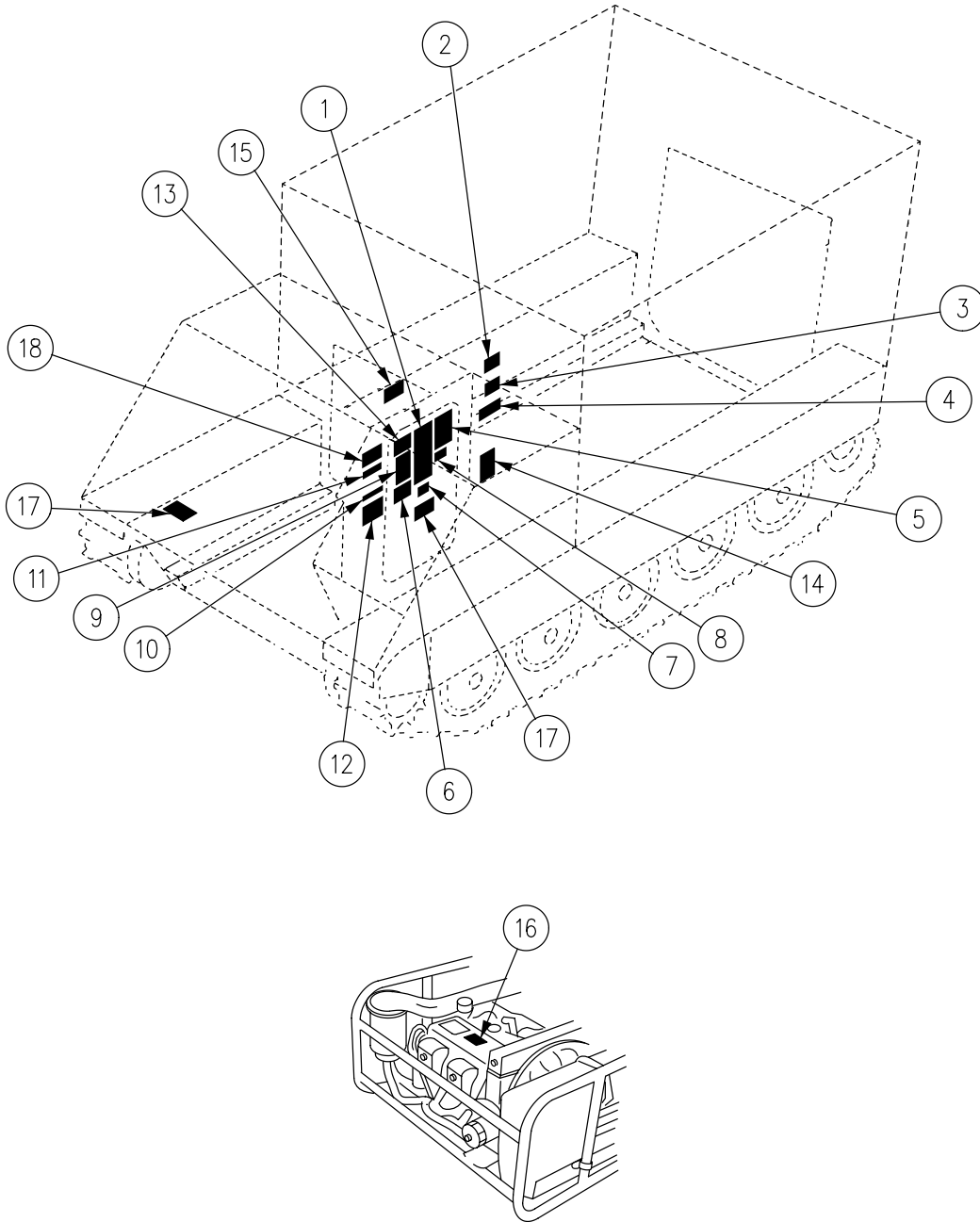

1. Marker, instruction, carrier operation
2. Marker, WARNING, ramp lock
3. Plate, warranty information
4. Marker, identification, carc paint
5. Marker, instruction, power train maintenance
6. Marker, identification, vehicle shipping data
7. Plate, instruction, engine idle RPM
8. Marker, WARNING, noise
9. Marker, instruction, ramp
10. Marker, instruction, ramp actuating lever
11. Marker, WARNING, stall check
12. Plate, identification, vehicle
13. Marker, instruction, speed shift limit
14. Decal, WARNING, exhaust gas (smell)
15. Marker, identification, ramp lock lever
16. Decal, WARNING, NBC generator set, engine air cleaner
(for 4.2 KW generator set only)
17. Decal, WARNING, NBC, engine air cleaner
18. Decal, WARNING, pivot steer

STOWAGE GUIDE - M1068A3 STANDARD INTEGRATED COMMAND POST SYSTEM MARKER AND DECAL LOCATIONS

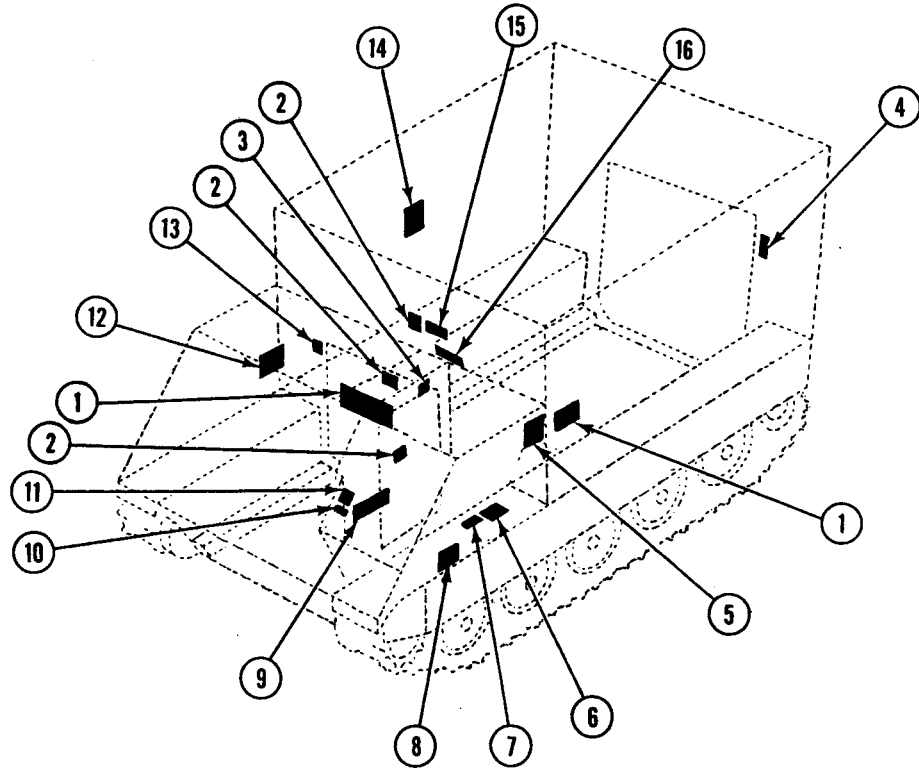

1. Power enclosure WARNING
2. Decal, WARNING, noise
3. Decal, WARNING, carbon monoxide (SMALL)
4. Decal, wall switch
5. Decal, CAUTION, fire extinguisher safety wire
6. Decal, tools
7. Decal, 5.56 ammunition
8. Decal, CAUTION, master switch
9. Decal, CAUTION, pivot steer
10. Marker, throttle
11. Decal, fuel shutoff
12. Decal, identification, fan oil gauge and fill
13. Marker, WARNING, personnel heater
14. Marker, identification, fire extinguisher
15. Marker, WARNING, carbon monoxide
16. Marker, WARNING, ramp lock instruction

STOWAGE GUIDE - M1068A3 STANDARD INTEGRATED COMMAND POST SYSTEM DECALS

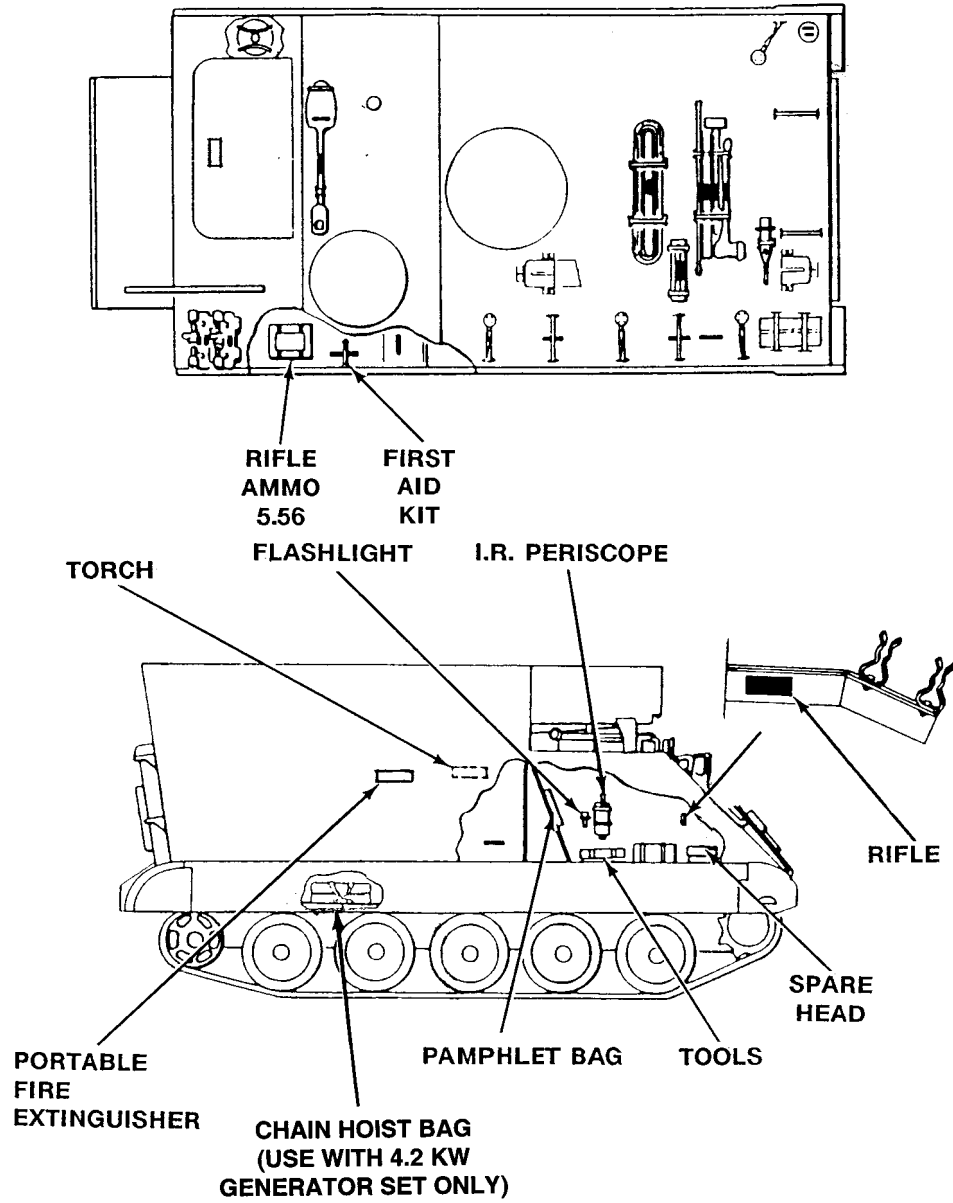

STOWAGE GUIDE - M1068A3 STANDARD INTEGRATED COMMAND POST SYSTEM LOCATIONS

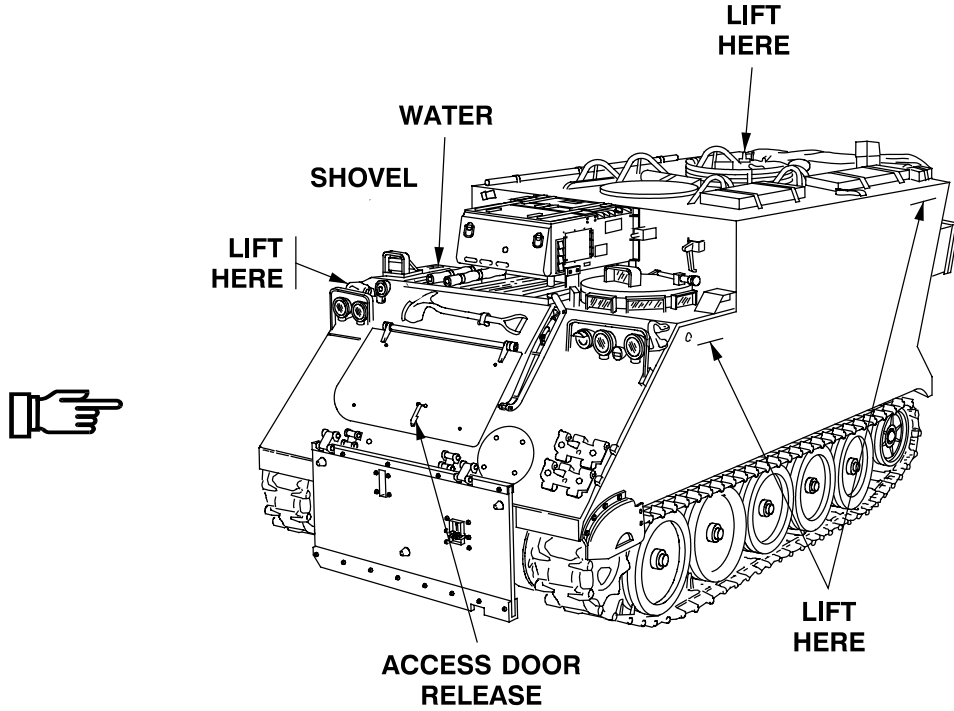

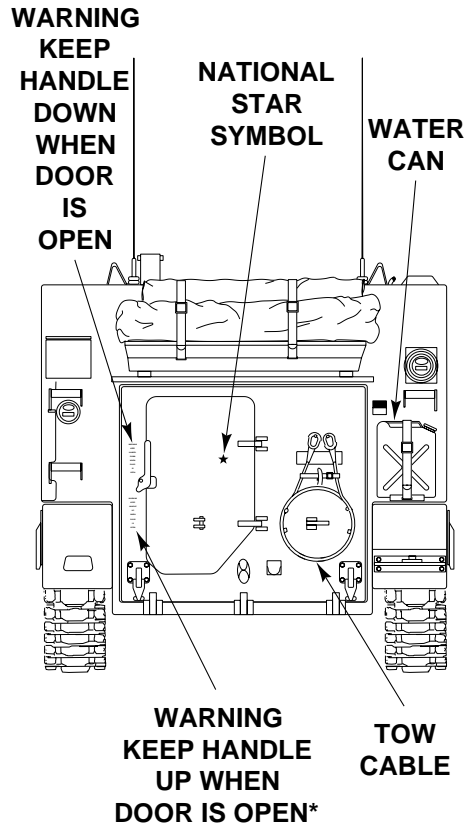

*STENCIL ON INSIDE OF RAMP

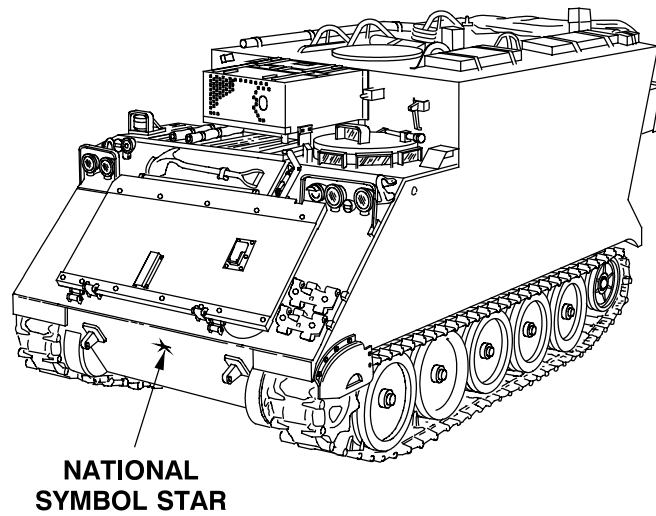

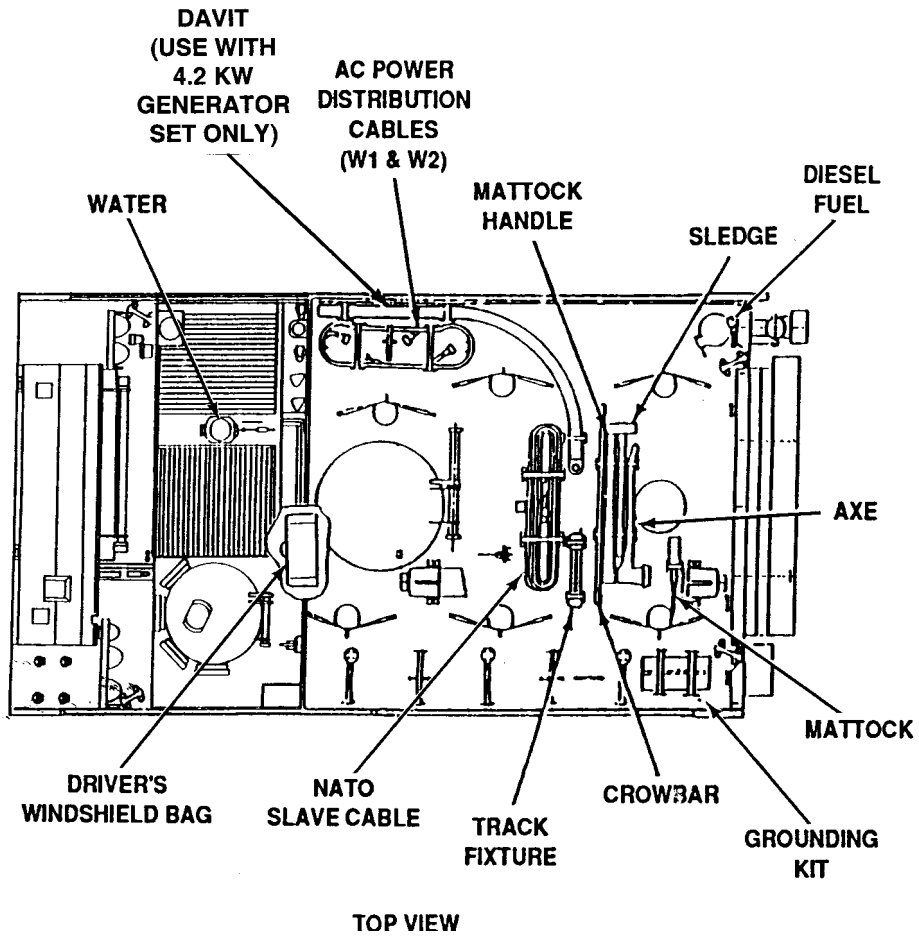

STOWAGE GUIDE - M1068A3 STANDARD INTEGRATED COMMAND POST SYSTEM STRAPPING DIAGRAM

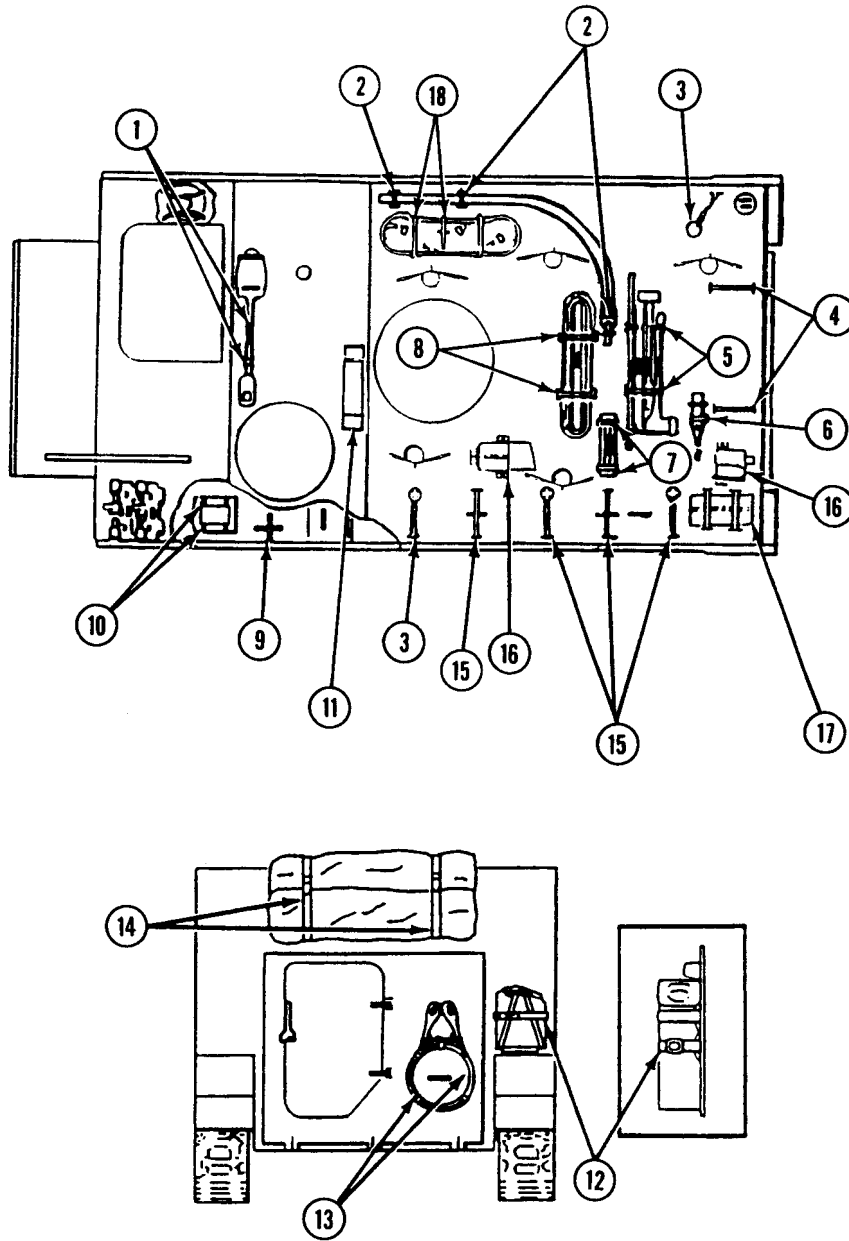

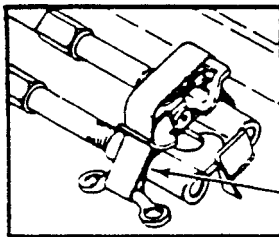
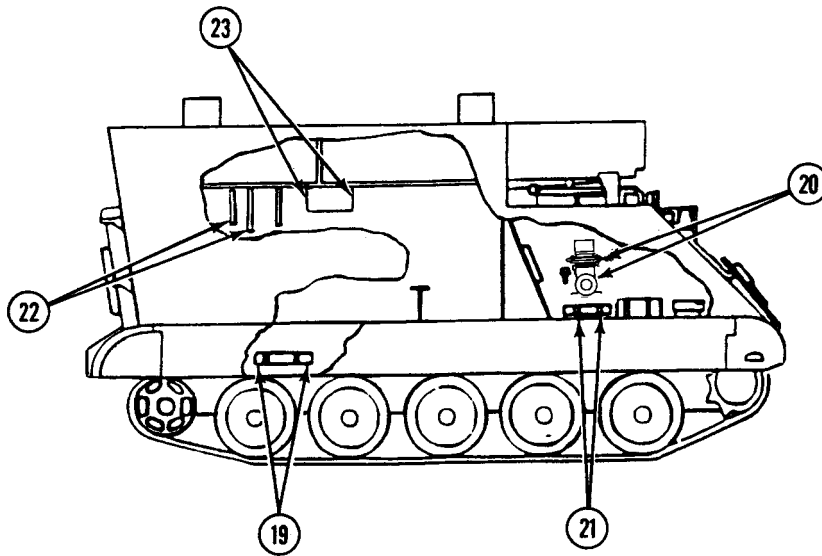

**PROPER METHOD OF STRAPPING.
MAKE CERTAIN BOTH LOOPS PASS
OVER TOP OF SECURED ITEM.**

STRAP KEY			
NO.	ITEM	QUANTITY	LENGTH (INCHES)
1	Shovel	2	33, 20
2	Davit (used for 4.2 KW generator set only)	3	22
3	Duffle bag/field pack	4	72, 84
4	Duffle bag/field pack	2	72
5	Pioneer tools	2	36
6	Mattock	1	36
7	Track fixture	2	28
8	Nato slave cable	2	36
9	First aid kit	1	24
10	Ammunition case, rifle 5.56	2	45
11	Driver's windshield bag	2	68
12	M13 Devon can	2	72
13	Tow cable	2	18, 30
14	Mapboard and table	2	114
15	Tent frame and fabric bags	4	100
16	Light set	2	45
17	Grounding kit	2	76
18	Generator cables (W1 and W2)	3	39, 45
19	Chain hoist bag (used for 4.2 KW generator set only)	1	39
20	Driver's night vision viewer AN/VVS-2	1	24
21	Tool bag	2	36
22	For radio set AN/PRC 8, 9 or 10	2	45
23	Alternate location for radio set AN/PRC-25	2	45

STOWAGE GUIDE - M1059A3 FULL TRACKED SMOKE GENERATOR CARRIER DATAPLATE AND MARKER LOCATIONS

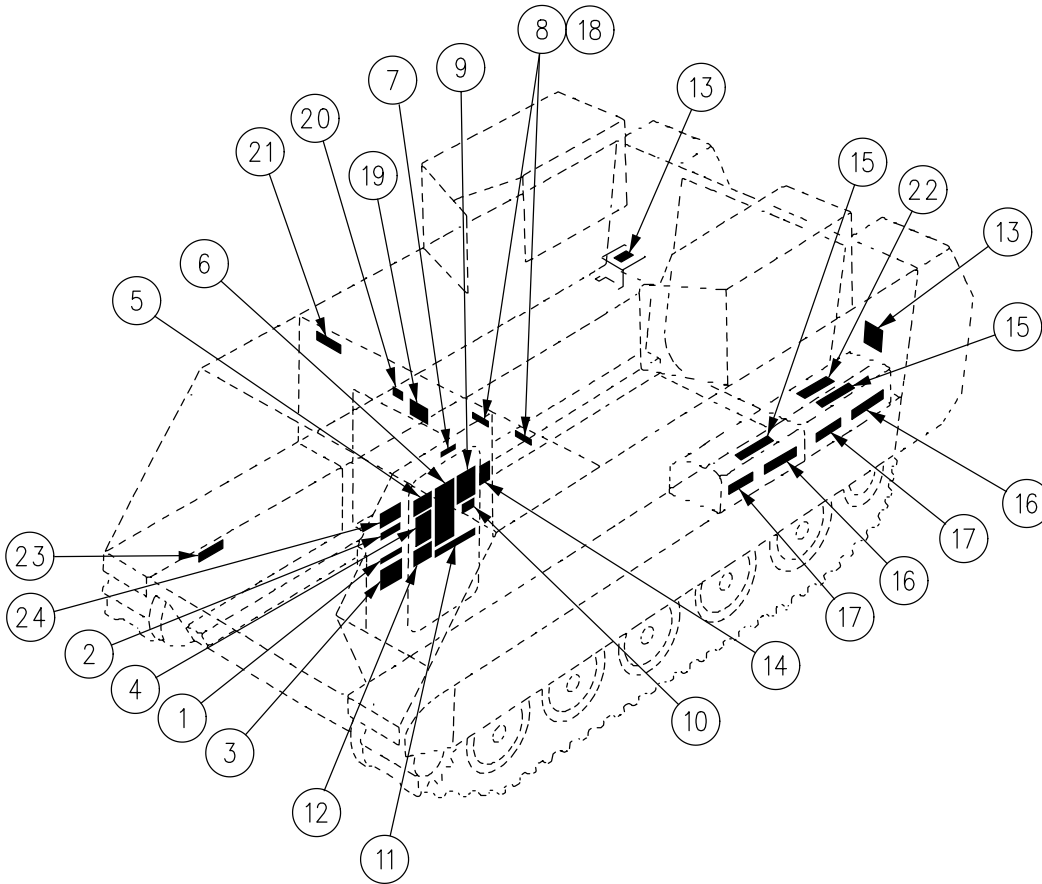

1. Marker, instruction, ramp actuating lever
2. Marker, WARNING, stall check
3. Plate, identification, vehicle
4. Marker, instruction, ramp operation
5. Marker, instruction, speed shift limit
6. Marker, instruction, vehicle operation
7. Marker, instruction, ramp lock lever
8. Marker, WARNING, ramp lock
9. Marker, instruction, power train maintenance
10. Marker, WARNING, noise
11. Marker, WARNING, multiple
12. Marker, identification, vehicle shipping data
13. Marker, CAUTION, fuel supply and return
14. Marker, WARNING, exhaust gas
15. Marker, instruction, battery service
16. Marker, WARNING, battery gas
17. Marker, WARNING, battery acid
18. Decal, WARNING, ramp
19. Decal, WARNING, exhaust gases
20. Marker, identification, paint
21. Marker, WARNING, personnel/equipment heater
22. Decal, tool bag
23. Marker, WARNING, NBC Air Cleaner
24. Decal, WARNING, pivot steer

STOWAGE GUIDE - M1059A3 FULL TRACKED SMOKE GENERATOR CARRIER DATAPLATE AND DECAL LOCATIONS

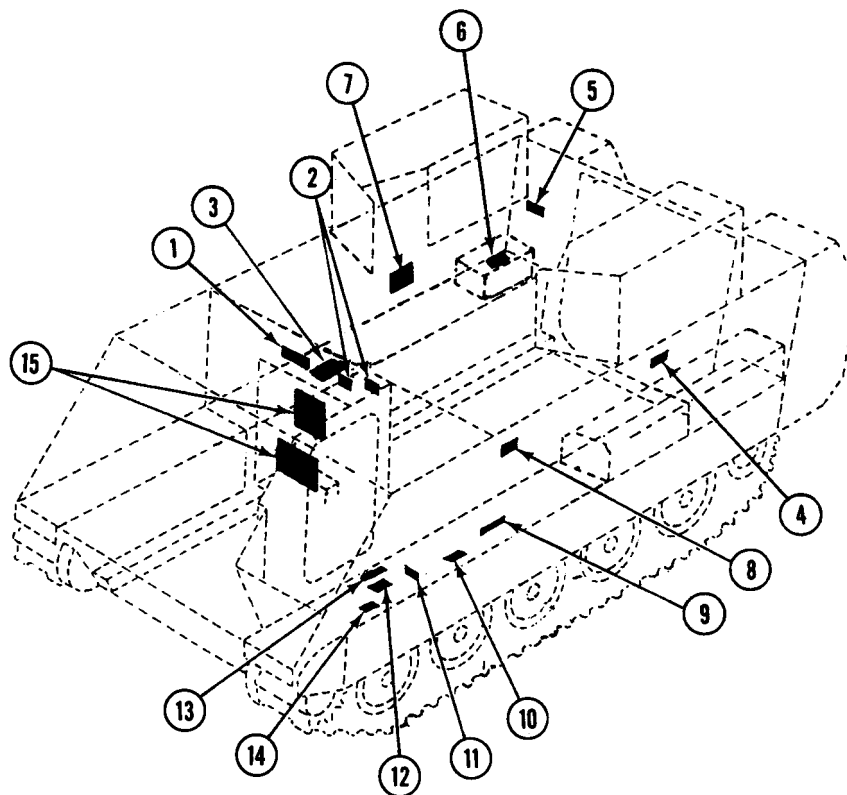

1. Decal, WARNING, multiple
2. Decal, WARNING, ramp lock
3. Decal, information, tools
4. Decal, WARNING, noise
5. Plate, identification, fire extinguisher
6. Plate, instruction, battery service
7. Decal, identification, periscope, M17
8. Plate, identification, fire extinguisher
9. Decal, identification, flashlight
10. Plate, identification, first aid kit
11. Plate, identification, rifle
12. Plate, identification, 5.56 ammunition
13. Plate, identification, spare barrel
14. Plate, identification, spare head
15. Decal, WARNING, carbon monoxide (LARGE)

STOWAGE GUIDE - M1059A3 FULL TRACKED SMOKE GENERATOR CARRIER DECALS AND STENCILS

NOTE

Signs outlined with boxes are decals applied in locations shown. Signs not outlined with boxes are stencils. Signs underlined are information.

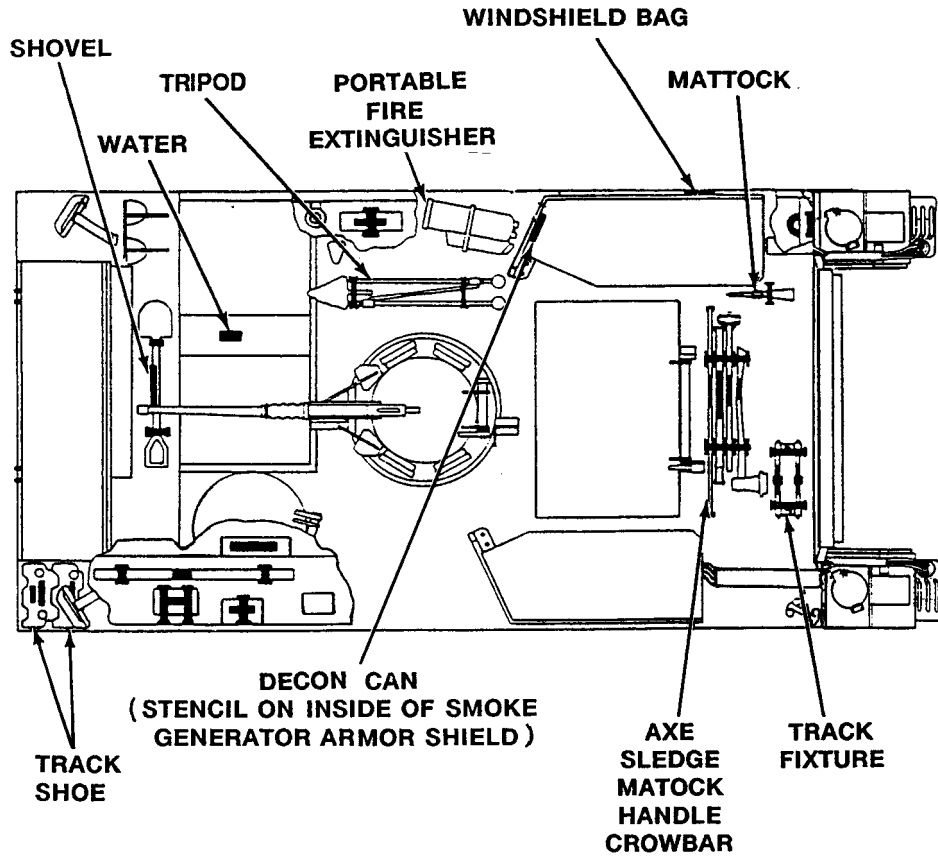

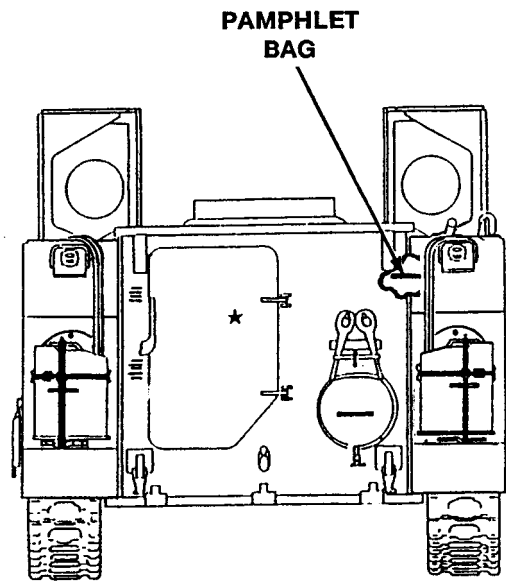
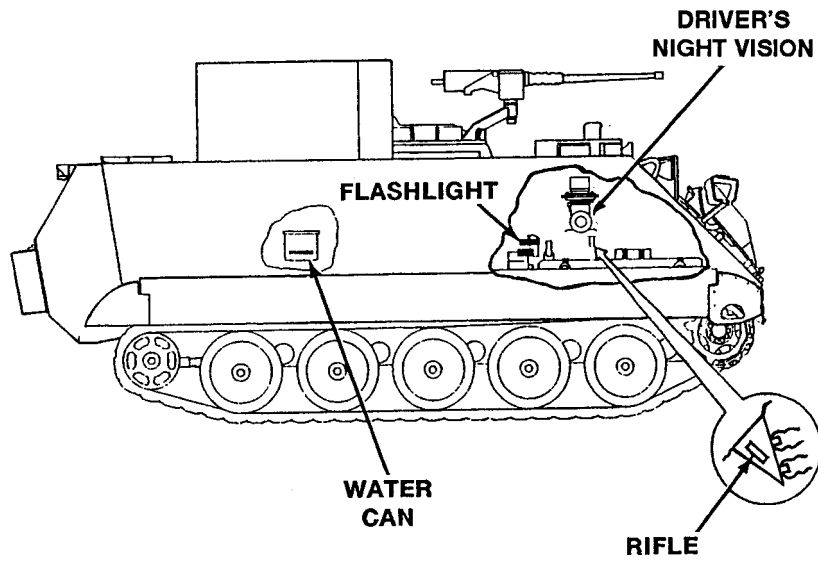

STOWAGE GUIDE - M1059A3 FULL TRACKED SMOKE GENERATOR CARRIER STENCILS

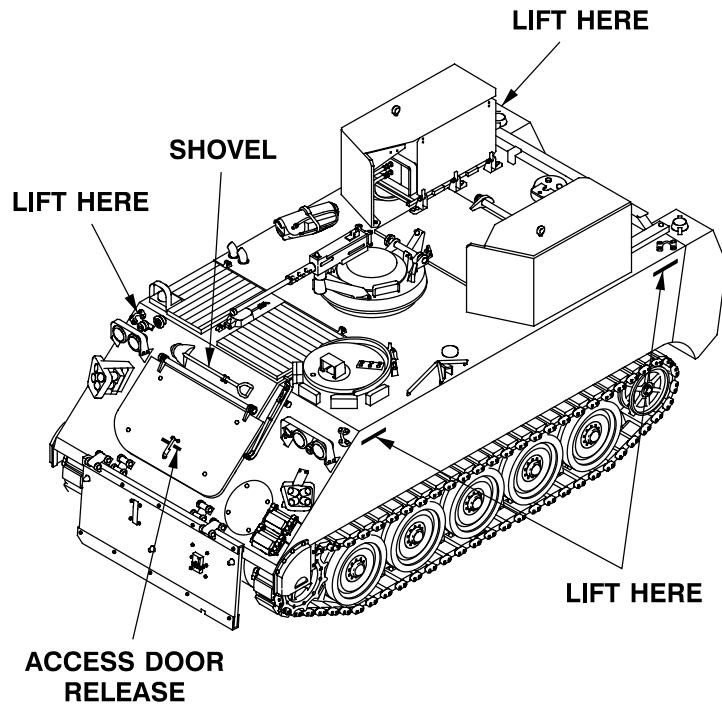

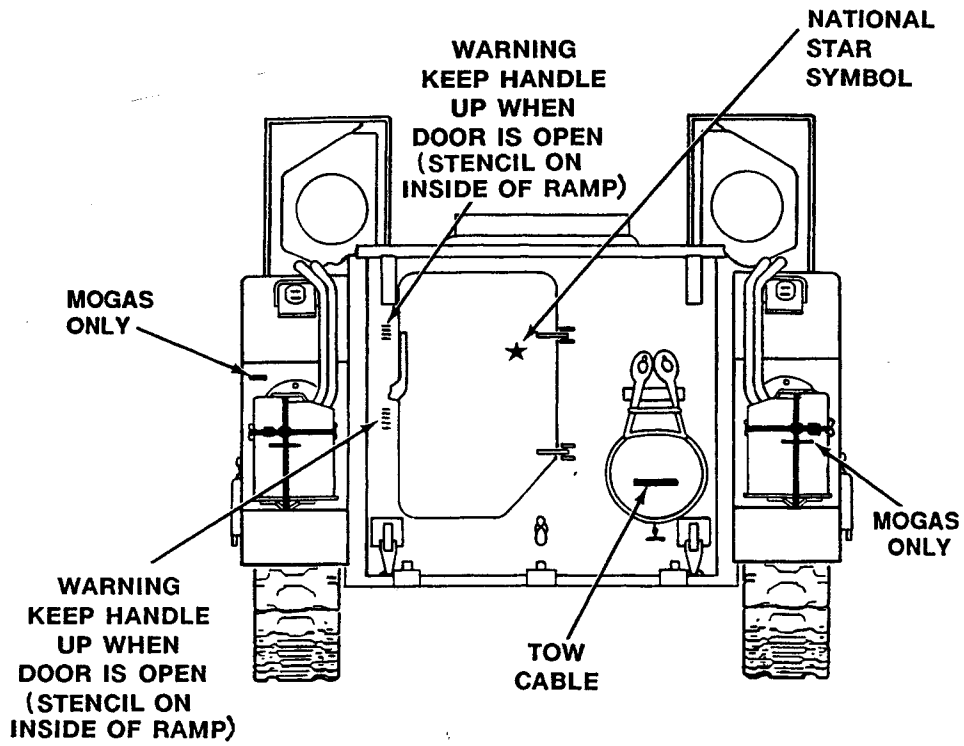

STOWAGE GUIDE - M1059A3 FULL TRACKED SMOKE GENERATOR CARRIER STRAPPING DIAGRAM

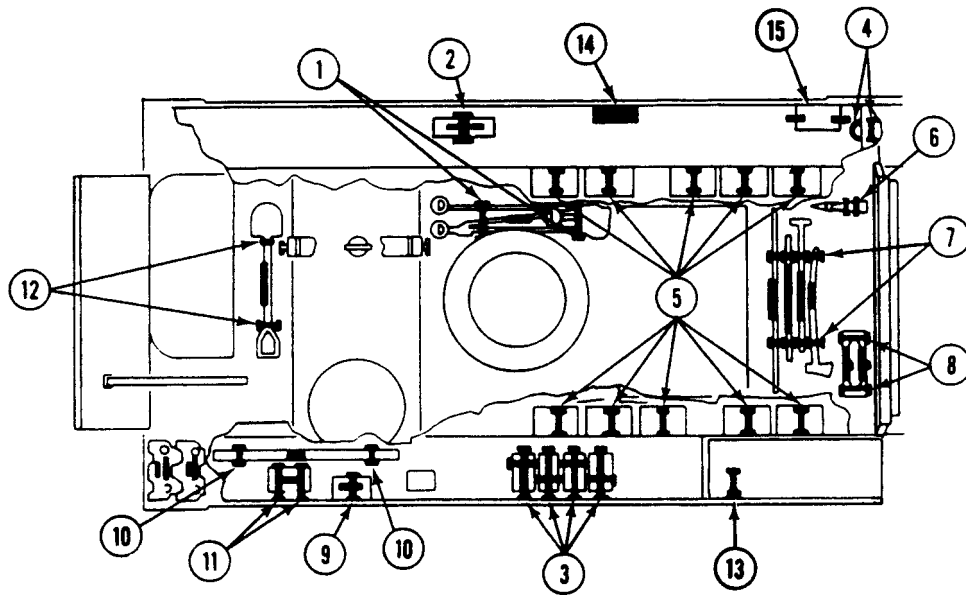

STRAP KEY			
NO.	ITEM	QUANTITY	LENGTH (INCHES)
1	Tripod	2	36
2	Tool bag	1	48
3	Ammunition box, caliber .50	Suggested use only, no straps furnished	
4	Fire extinguisher	2	24
5	Miscellaneous stowage	10	39
6	Mattock	1	24
7	Pioneer tools	2	36
8	Track fixture	2	28
9	First aid kit	1	24
10	Spare barrel, caliber .50	2	24
11	Ammunition cases, rifle, 5.56 mm	2	45
12	Shovel	2	33, 20
13	Miscellaneous stowage	1	48
14	Water can	2	72
15	Spare M17 periscope	0	-

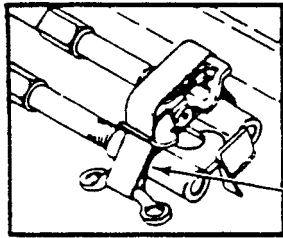
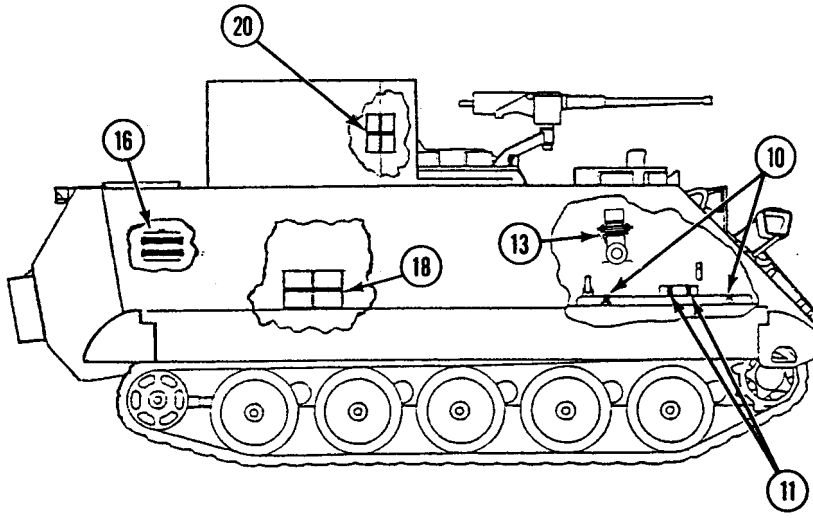

**PROPER METHOD OF STRAPPING.
MAKE CERTAIN BOTH LOOPS PASS
OVER TOP OF SECURED ITEM.**

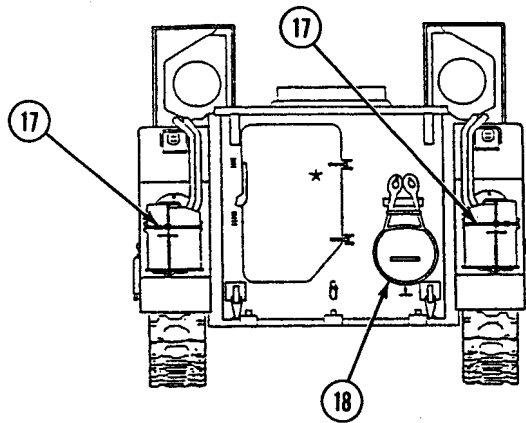

STRAP KEY (Cont)			
NO.	ITEM	QUANTITY	LENGTH (INCHES)
16	Driver's night vision viewer AN/VVS-2	1	24
17	MOGAS	4	72, 88, 108
18	Tow cable	2	18, 30
19	Driver's windshield bag	3	68
20	Decon can M13	2	72

STOWAGE GUIDE - M1064A3 120-MM SELF PROPELLED MORTAR PLATE, MARKER, AND DECAL LOCATIONS

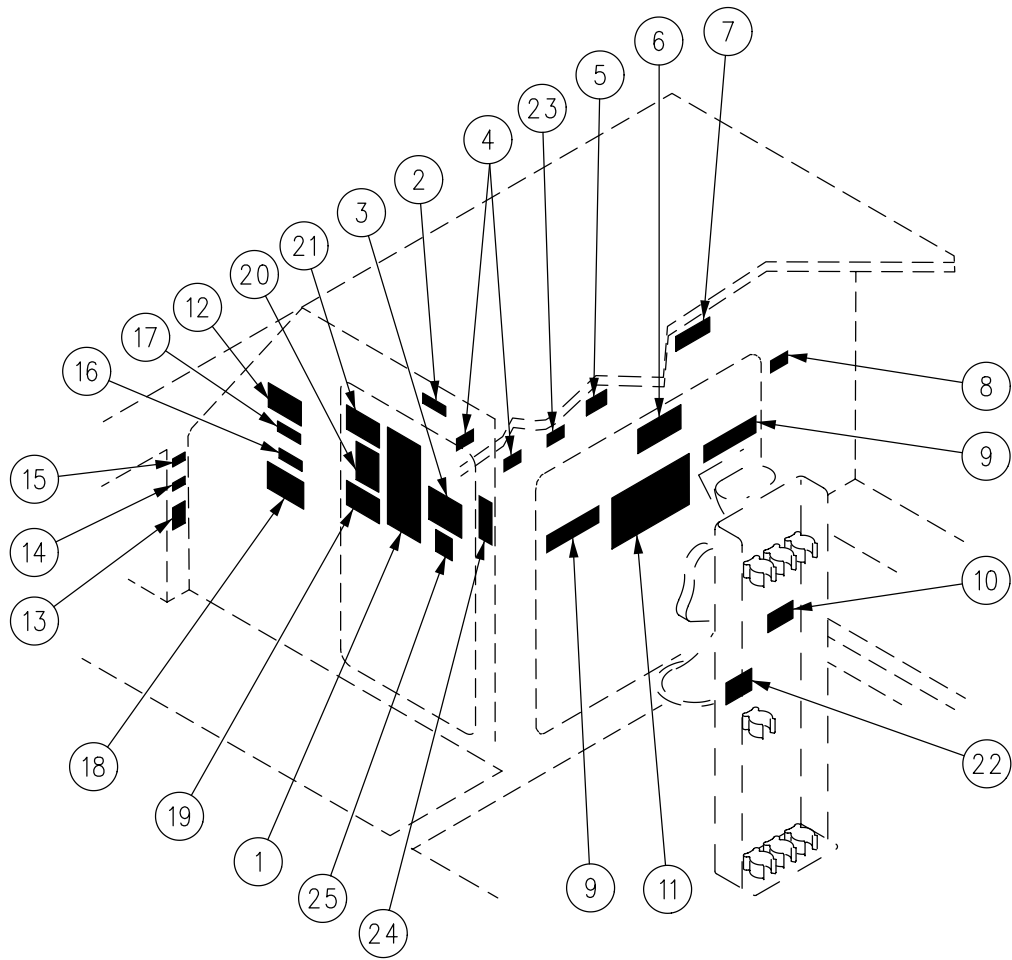

1. Marker, instruction, vehicle operation
2. Marker, WARNING, ramp lock
3. Marker, instruction, power train maintenance
4. Marker, instruction, ramp lock
5. Marker, WARNING, mortar alignment
6. Marker, WARNING, water operation
7. Marker, identification, curtain air grille
8. Marker, WARNING, personnel/equipment heater
9. Marker, identification, pamphlet bag
10. Marker, identification, rifle
11. Decal, WARNING, carbon monoxide (LARGE)
12. Decal, WARNING, pivot steer
13. Marker, engine idling
14. Marker, throttle
15. Decal, fuel shutoff
16. Marker, instruction, ramp actuating lever
17. Marker, WARNING, stall check
18. Plate, identification, vehicle
19. Plate, identification, vehicle shipping data
20. Marker, instruction, ramp operation
21. Marker, instruction, speed shift limit
22. Decal, identification, sight unit
23. Marker, identification, carc unit
24. Marker, WARNING, exhaust gas
25. Marker, CAUTION, noise

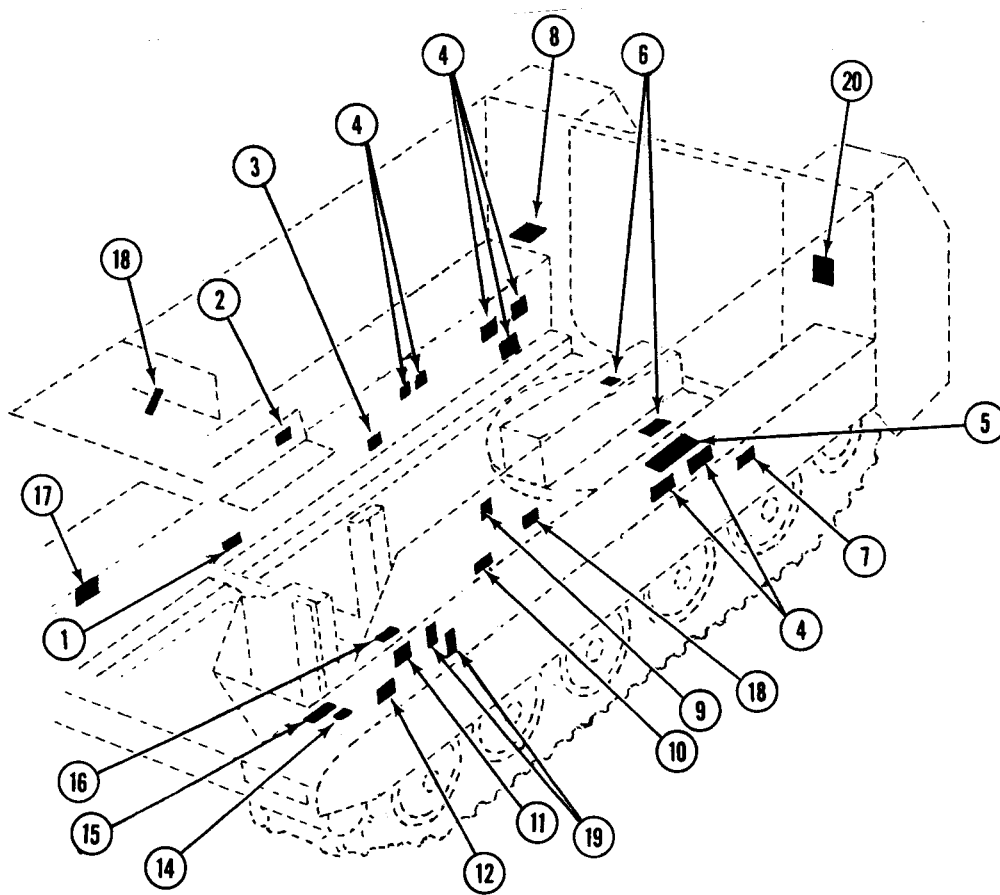

1. Decal, machete
2. Decal, panel set
3. Decal, sight unit
4. Decal, 50 cal ammunition
5. Decal, gun tool kit
6. Decal, 5.56 mm ammunition
7. Decal, boresight
8. Marker, driver's windshield
9. Decal, CAUTION, fire extinguisher safety wire
10. Decal, flashlight
11. Decal, CAUTION, master switch
12. Decal, tools
13. Deleted
14. Decal, first aid kit
15. Decal, periscope
16. Decal, spare head
17. Decal, WARNING, NBC, engine air cleaner
18. Decal, identification, fan oil gauge and fill
19. Decal, CAUTION, grenades
20. Marker, identification, fuel supply/return

STOWAGE GUIDE - M1064A3 120-MM SELF PROPELLED MORTAR STENCIL LOCATIONS

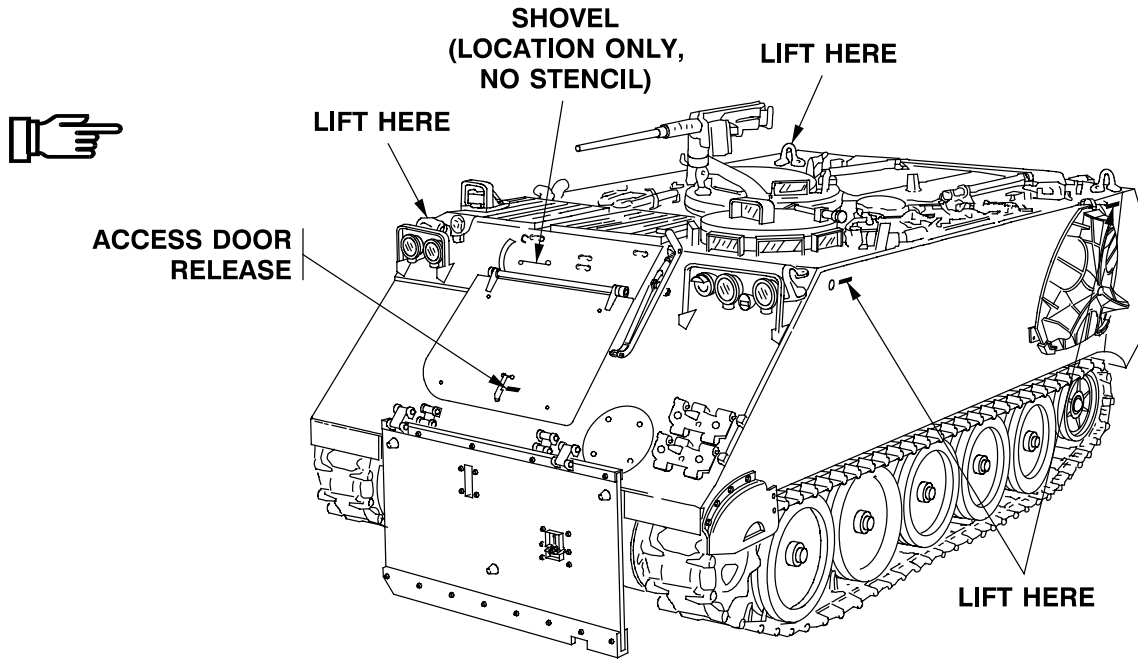

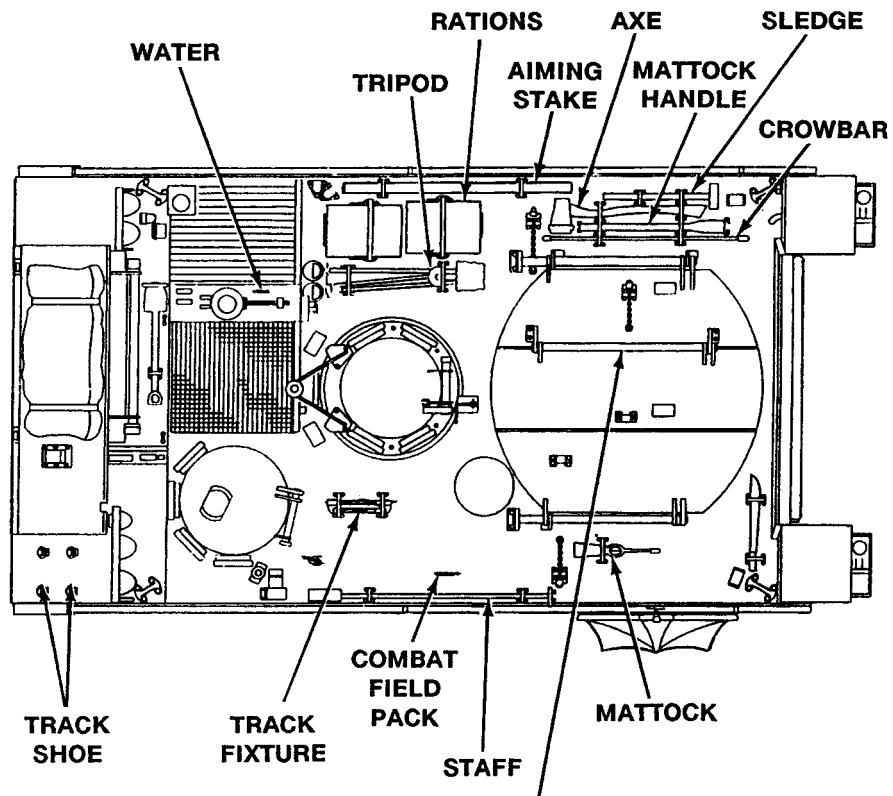

**NOTE: POSITION COMMANDER'S
CUPOLA SIDWAYS BEFORE
OPENING OR CLOSING THIS DOOR
IF COMMANDER'S HATCH IS OPEN
(STENCIL INSIDE OF MORTAR DOOR)**

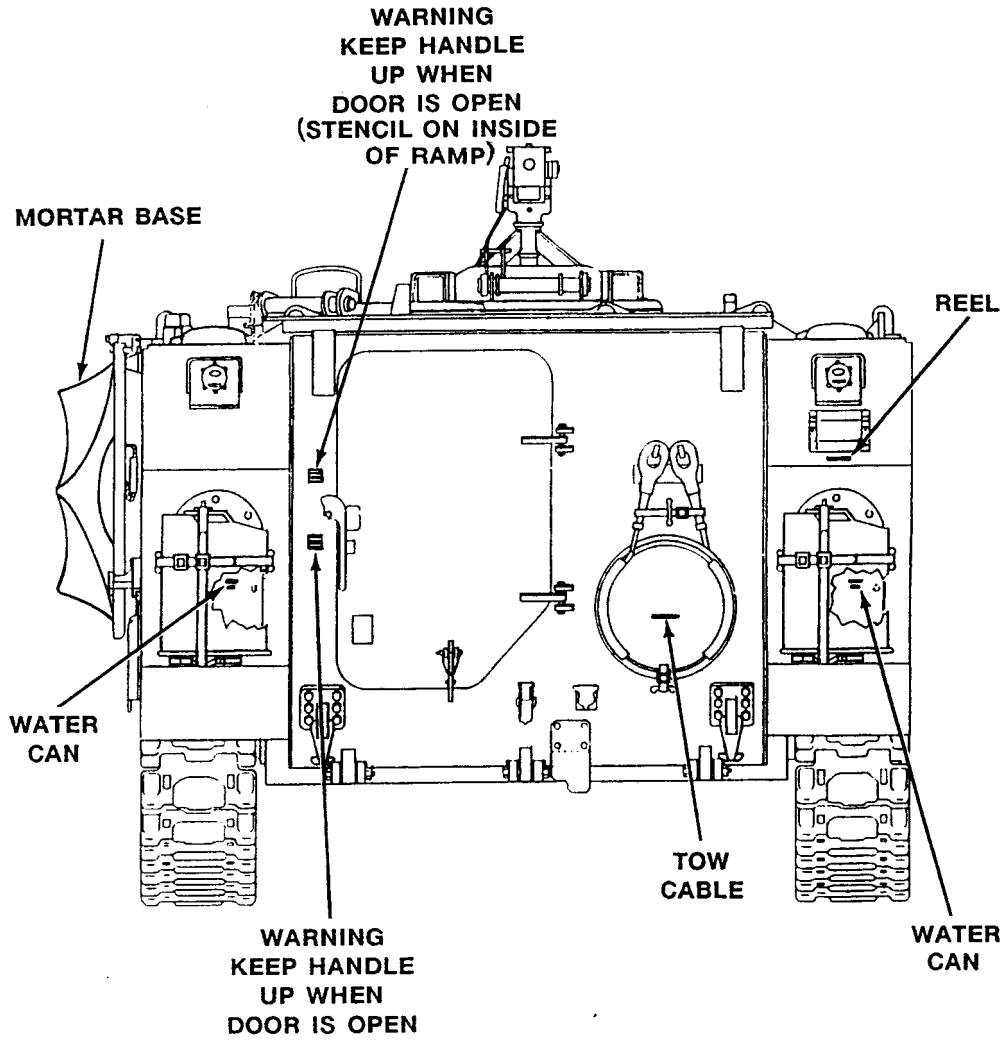

STOWAGE GUIDE - M1064A3 120-MM SELF PROPELLED MORTAR STRAPPING DIAGRAM

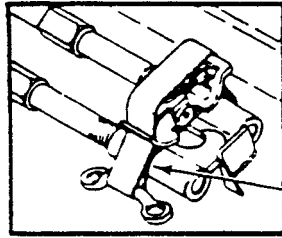

PROPER METHOD OF STRAPPING.
MAKE CERTAIN BOTH LOOPS PASS
OVER TOP OF SECURED ITEM.

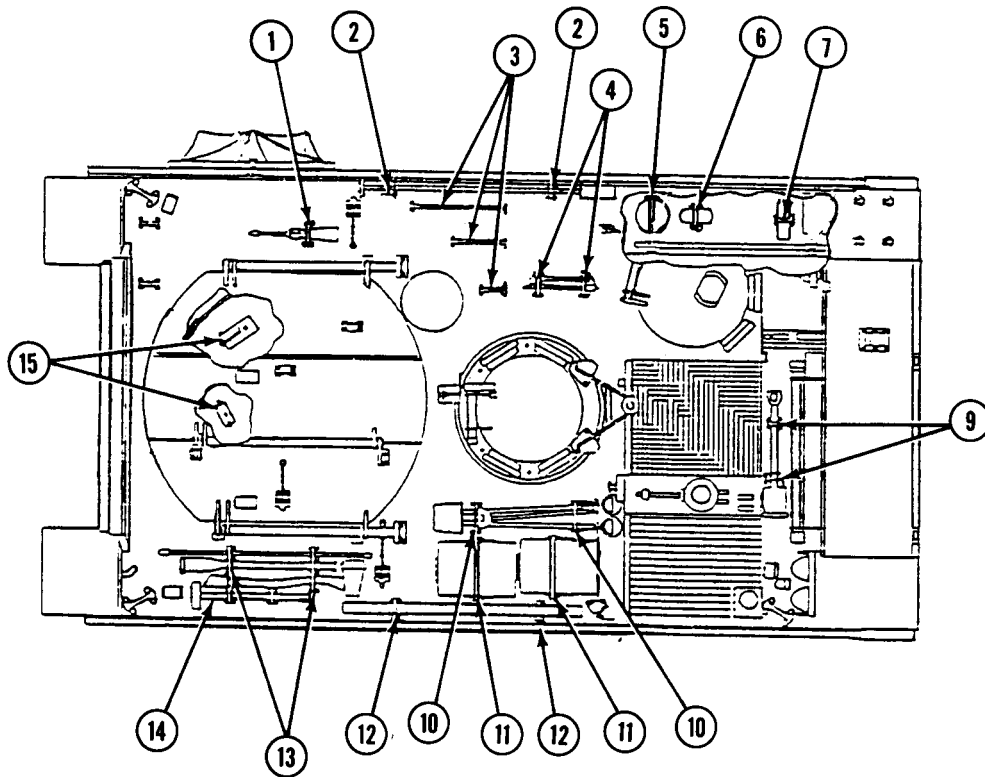

STRAP KEY			
NO.	ITEM	QUANTITY	LENGTH (INCHES)
1	Mattock	1	24
2	Cleaning staff	2	12
3	Field packs	3	80, 64, 48
4	Track fixture	2	18
5	Cock set	1	36
6	Binoculars	1	48
7	First aid kit	1	39
8	Deleted	Deleted	Deleted
9	Shovel	2	20, 33
10	Tripod	2	36
11	Field rations	2	64
12	Aiming post M1A3	2	16
13	Pioneer tools	2	30, 39
14	Sledge hammer	1	12
15	Ammunition boxes, rifle 5.56	2	51, 57

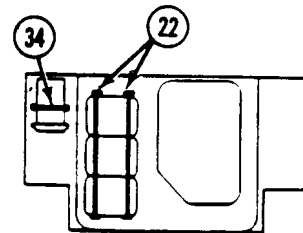
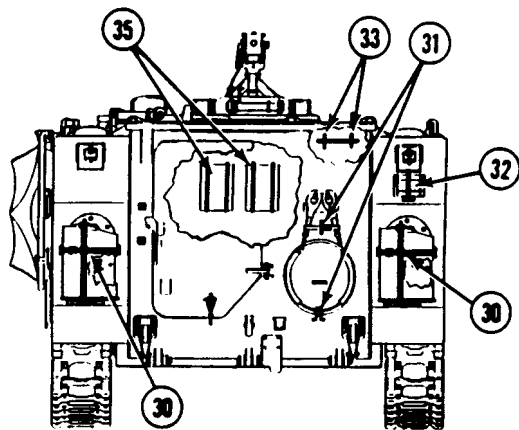
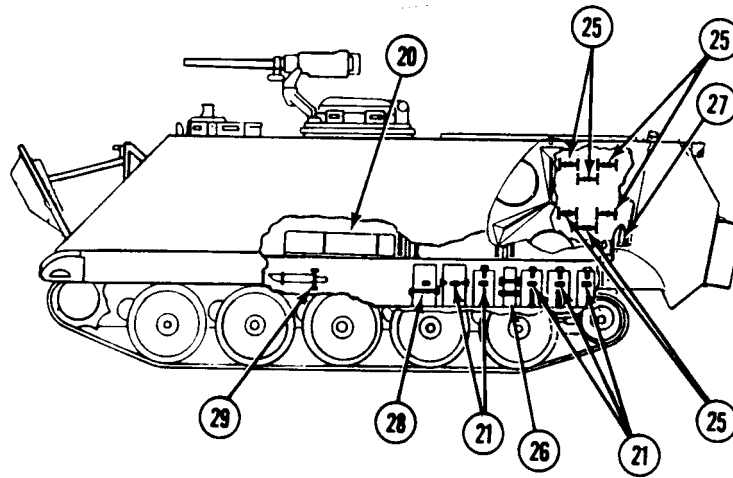
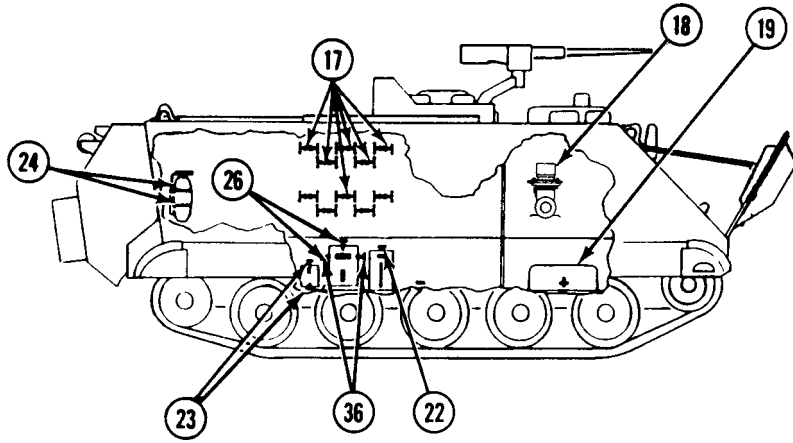

STRAP KEY (Cont)			
NO.	ITEM	QUANTITY	LENGTH (INCHES)
17	Mortar ammo cartridges	10	80
18	Driver's night vision viewer AN/VVS-2	1	24
19	Tool bag	1	36
20	Panel set	2	20
21	Ammo boxes, .50 cal	6	42, 45
22	Lighting chest	2	39, 54
23	Boresight	1	28
24	Fire extinguisher	2	24
25	Mortar ammo cartridges	6	80
26	Roll gun parts and tools	1	28
27	Driver's windshield bag	1	36
28	Sight unit carrying case	1	51
29	Machete	1	16
30	Water can	4	72
31	Tow cable	2	30, 18
32	Reel	1	48
33	Air grille curatin	2	30
34	Portable radio set	1	36
35	Pamphlet bag	4	30
36	Sleeping bags/duffle bags	2	174

STOWAGE GUIDE - M58 FULL TRACKED MECHANIZED SMOKE OBSCURANT CARRIER DATAPLATE AND MARKER LOCATIONS

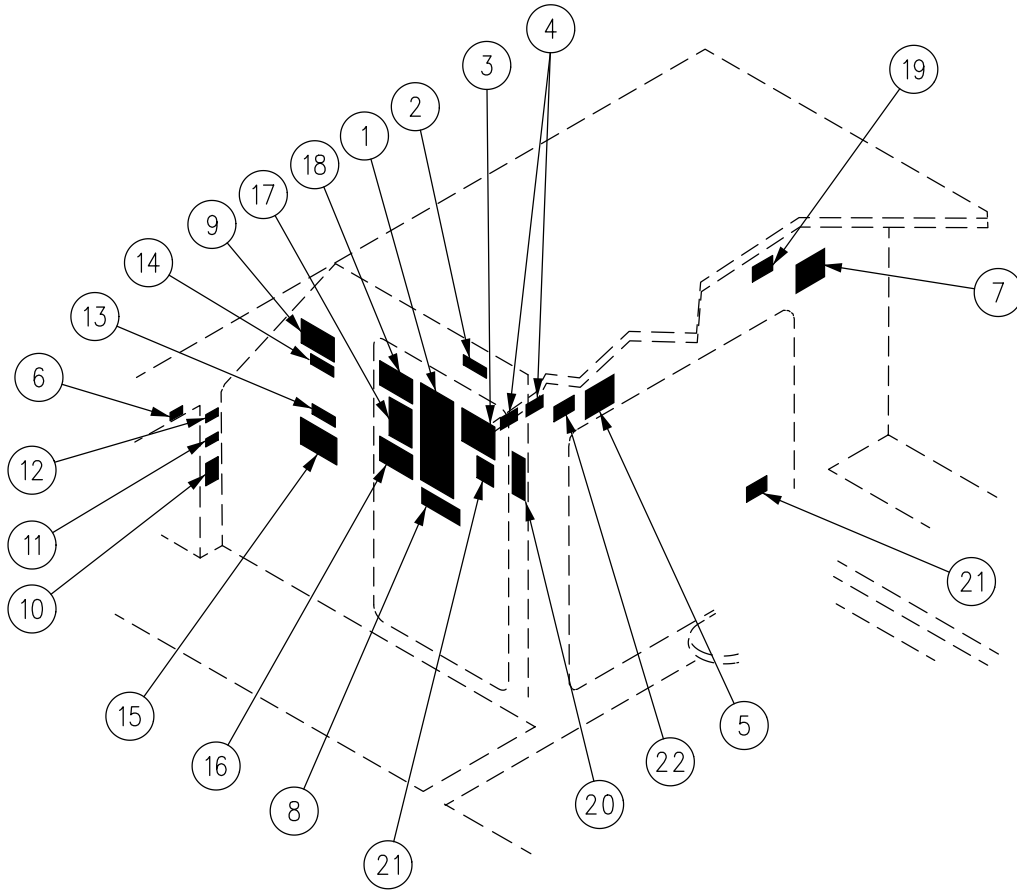

1. Marker, instruction, vehicle operation
2. Marker, instruction, ramp lock
3. Marker, instruction, power train maintenance
4. Marker, WARNING, ramp lock
5. Plate, information, warranty
6. Marker, tow start
7. Marker, WARNING, personnel/equipment heater
8. Marker, WARNING, multiple
9. Decal, WARNING, pivot steer
10. Plate, engine idling
11. Decal, throttle
12. Decal, fuel shutoff
13. Marker, instruction ramp actuating lever
14. Marker, WARNING, stall check
15. Plate, identification, vehicle
16. Plate, identification, vehicle shipping data
17. Marker, instruction, ramp operation
18. Marker, instruction, speed shift limit
19. Marker, identification, carc paint
20. Marker, WARNING, exhaust gas
21. Marker, CAUTION, noise
22. Marker, WARNING, exhaust gas

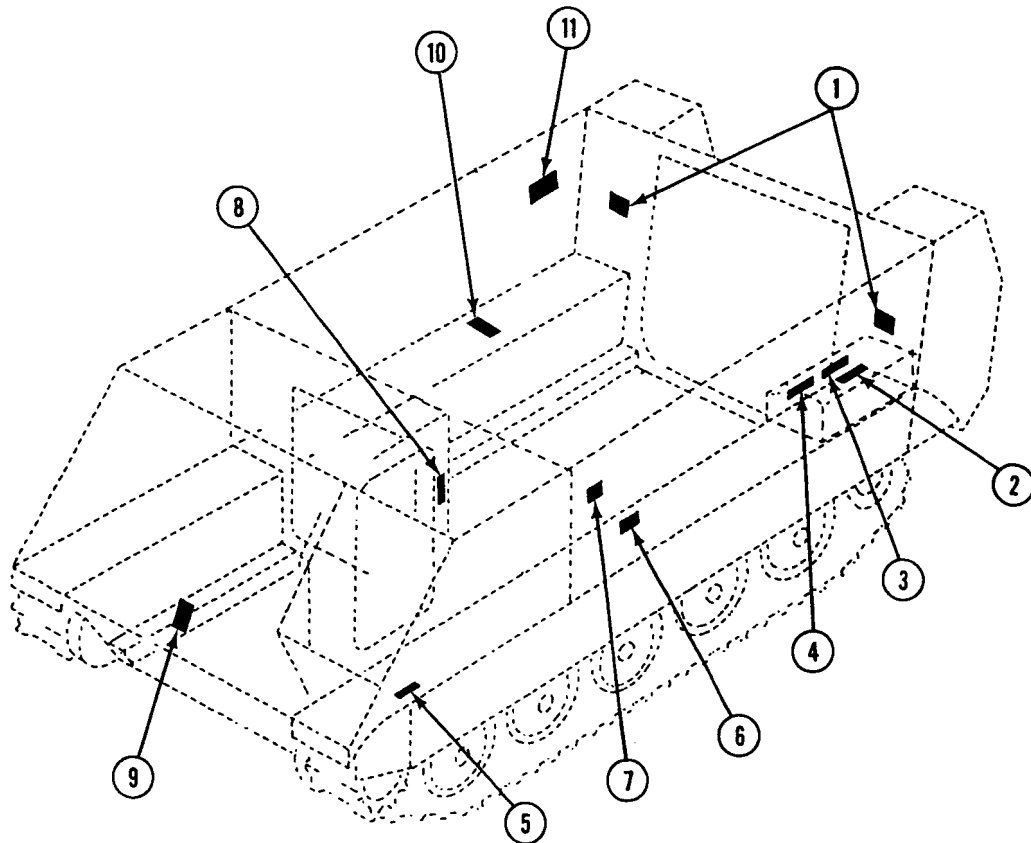
STOWAGE GUIDE - M58 FULL TRACKED MECHANIZED SMOKE OBSCURANT CARRIER MARKER AND DECAL LOCATIONS

1. Marker, CAUTION, fuel supply and return
2. Marker, instruction, battery service
3. Marker, WARNING, battery gas
4. Marker, WARNING, battery acid
5. Decal, tool bag
6. Marker, WARNING, NBC system
7. Decal, CAUTION, fire extinguisher
8. Marker, WARNING, pivot steer
9. Marker, WARNING, power plant door (inside driver's hatch)
10. Marker, WARNING, hot surface
11. Marker, CAUTION, noise

STOWAGE GUIDE - M58 FULL TRACKED MECHANIZED SMOKE OBSCURANT CARRIER STENCIL LOCATIONS

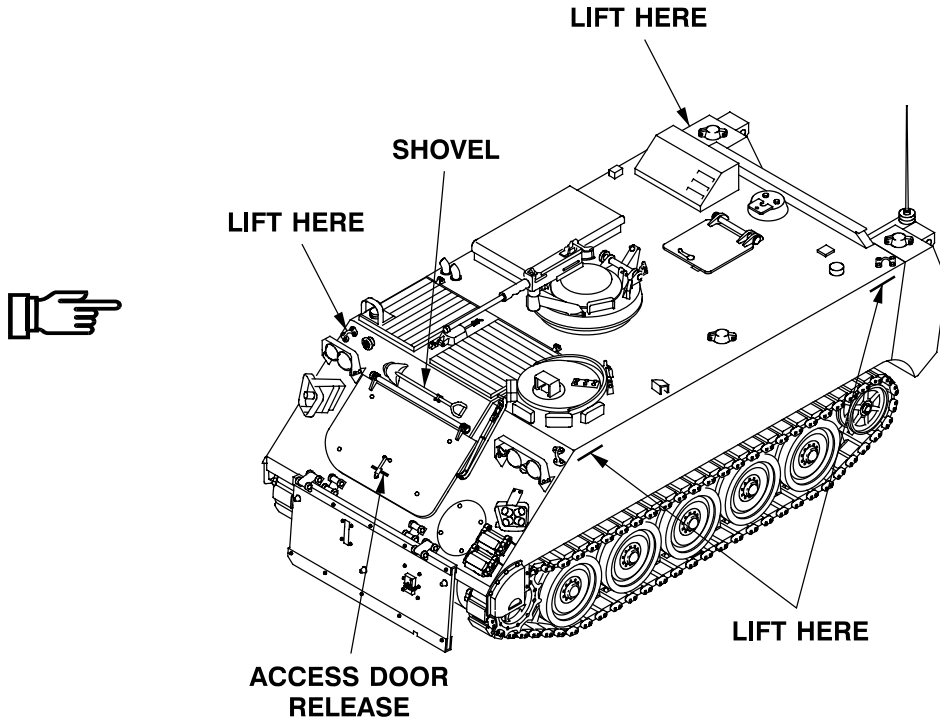

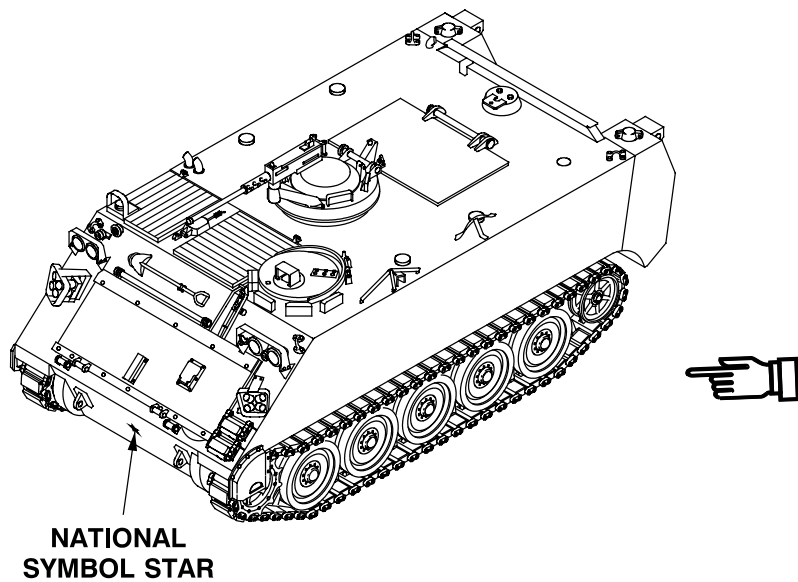
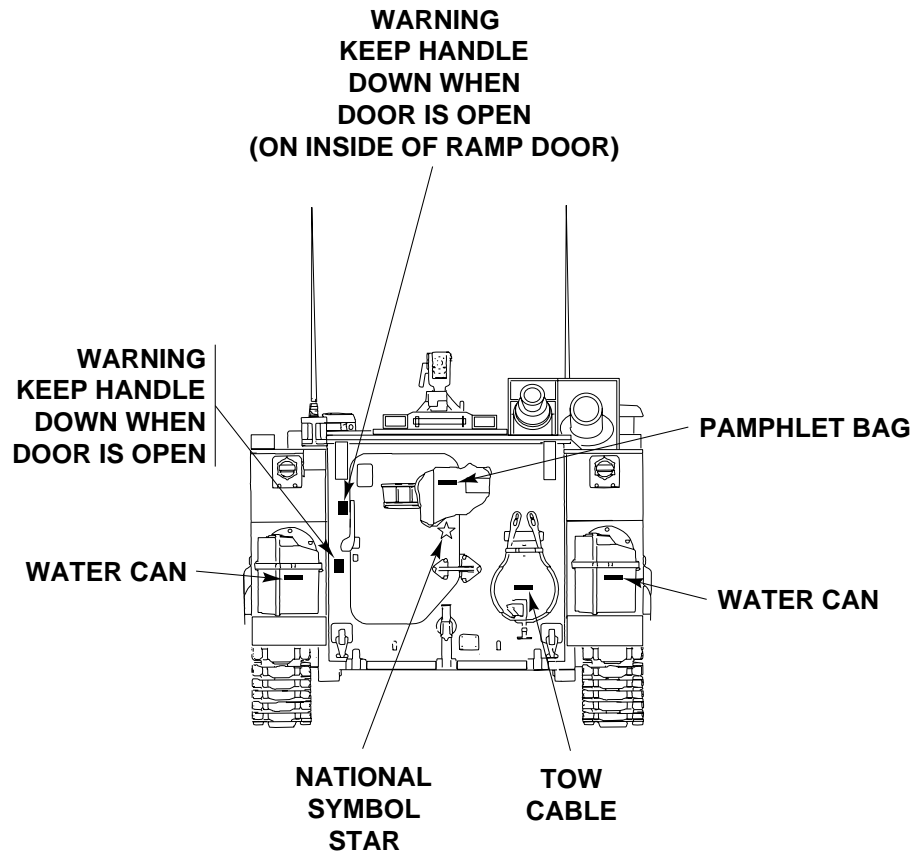

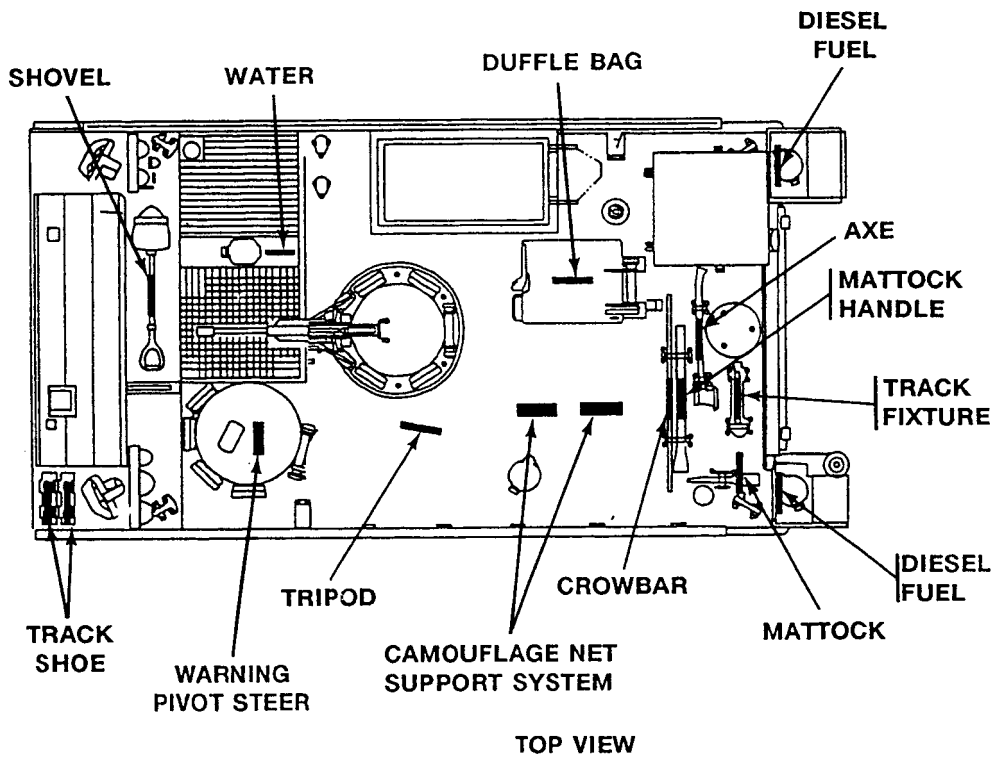

STOWAGE GUIDE - M58 FULL TRACKED MECHANIZED SMOKE OBSCURANT CARRIER DECALS AND STENCILS

NOTE

Signs outlined with boxes are decals applied in locations shown. Signs not outlined with boxes are stencils.

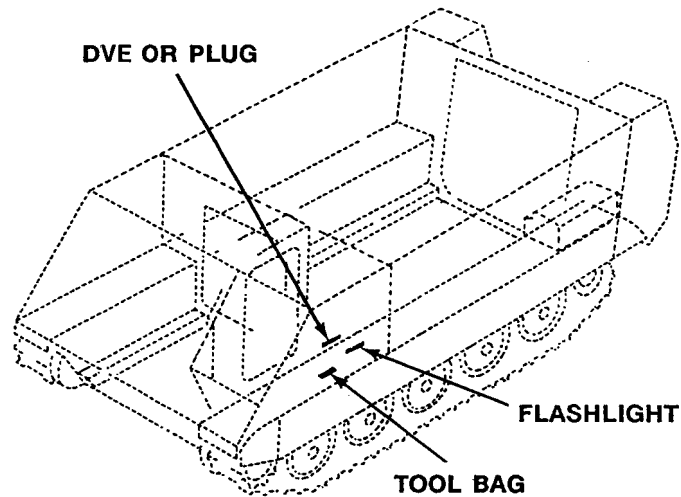
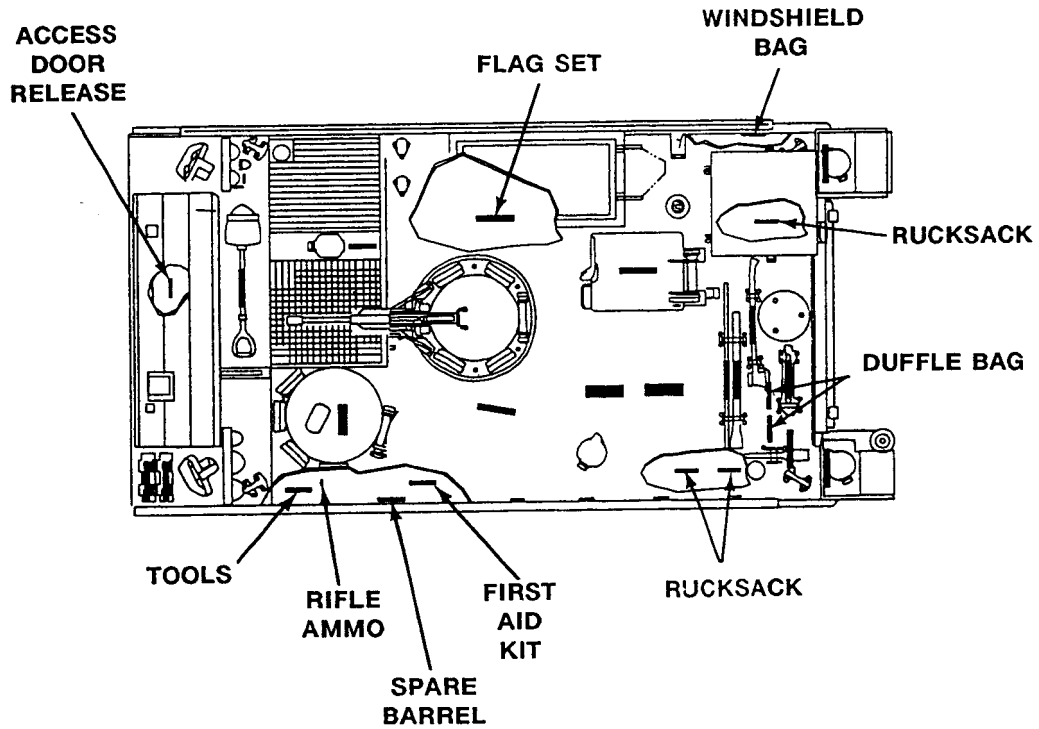

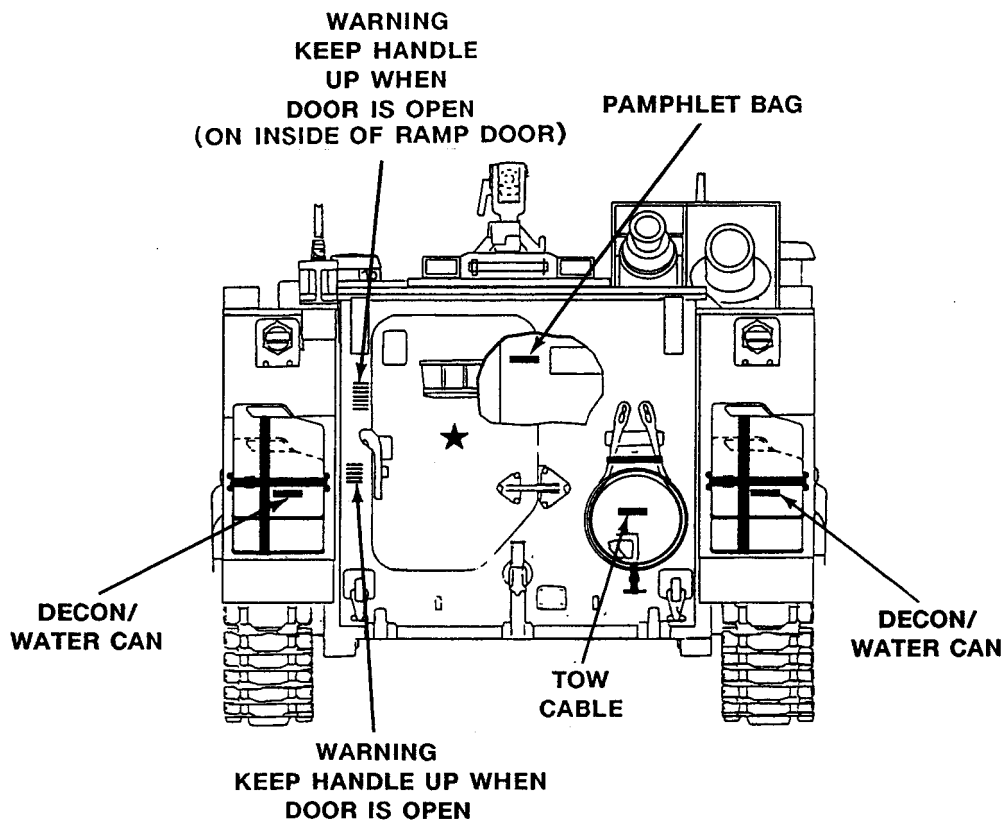

STOWAGE GUIDE - M58 FULL TRACKED MECHANIZED SMOKE OBSCURANT CARRIER STRAPPING DIAGRAM

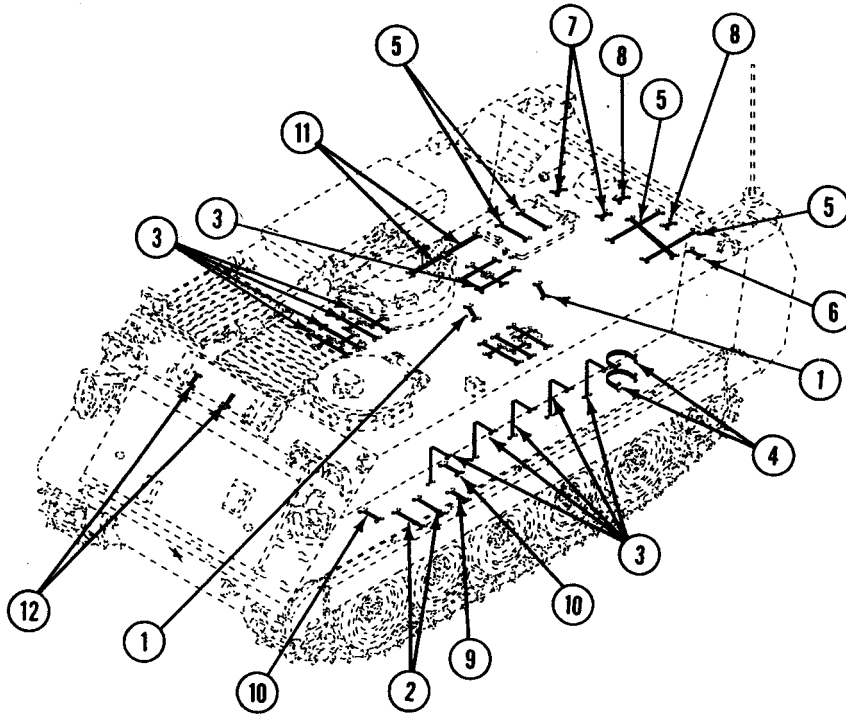

STRAP KEY			
NO.	ITEM	QUANTITY	LENGTH (INCHES)
1	Tripod	2	24
2	Tool bag	1	45
3	Ammunition box, caliber .50	11	48, 60
4	Fire extinguisher	2	24
5	Duffle bags	6	100, 132
6	Mattock	1	24
7	Pioneer tools	2	30
8	Track fixture	2	28
9	First aid kit	1	24
10	Spare barrel, caliber .50	2	24
11	Ammunition cases, rifle	6	39, 60
12	Shovel	2	33, 20

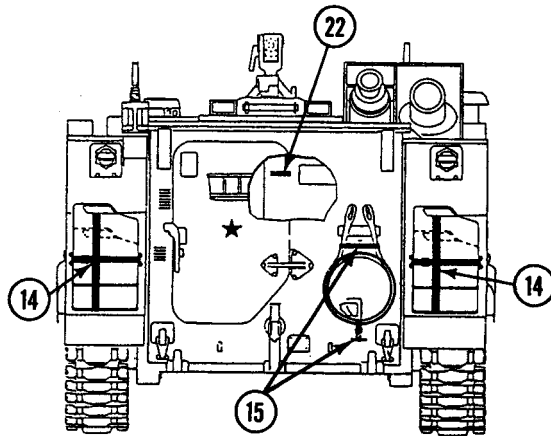
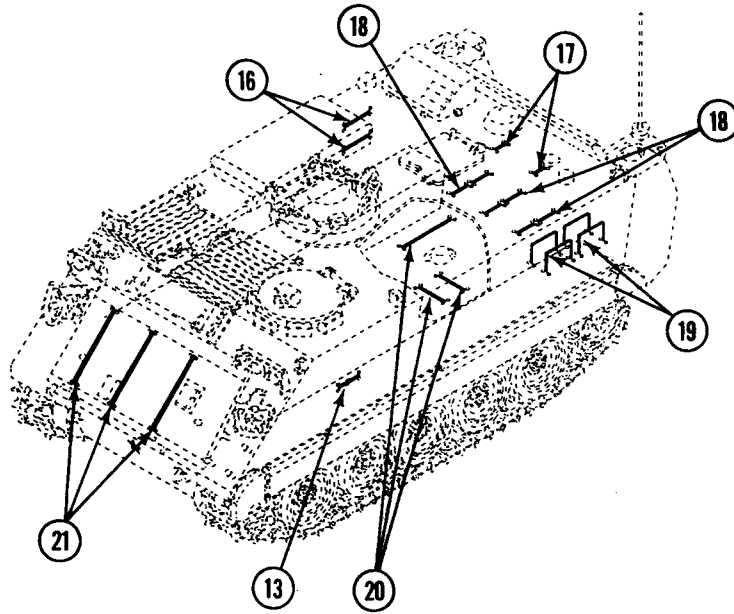

STRAP KEY (Cont)			
NO.	ITEM	QUANTITY	LENGTH (INCHES)
13	Driver's vision enhancer	2	20, 24
14	MOGAS, M13 decon or water	6	64, 100
15	Tow cable	2	18, 30
16	Driver's windshield bag	2	68
17	Axe	2	24
18	Camouflage net support	6	42
19	Rucksack	7	96
20	MRE	3	76
21	Camouflage net	3	126
22	Pamphlet bag	2	30

STANDARD LOAD PLAN**0106 00****INTRODUCTION****NOTE**

This load plan supersedes all previously published versions.

This work package provides load plans for the M113A3 and M1064A3 carriers. This standard load plan is designed to supplement the Stowage and Sign Guide (WP 0105 00). This standard load plan includes selected items of personal and unit equipment. These items are issued to most units within the Army equipped carriers. Equipment not shown in either this work package or in the Stowage and Sign Guide (WP 0105 00) may be loaded in accordance with local command policy.

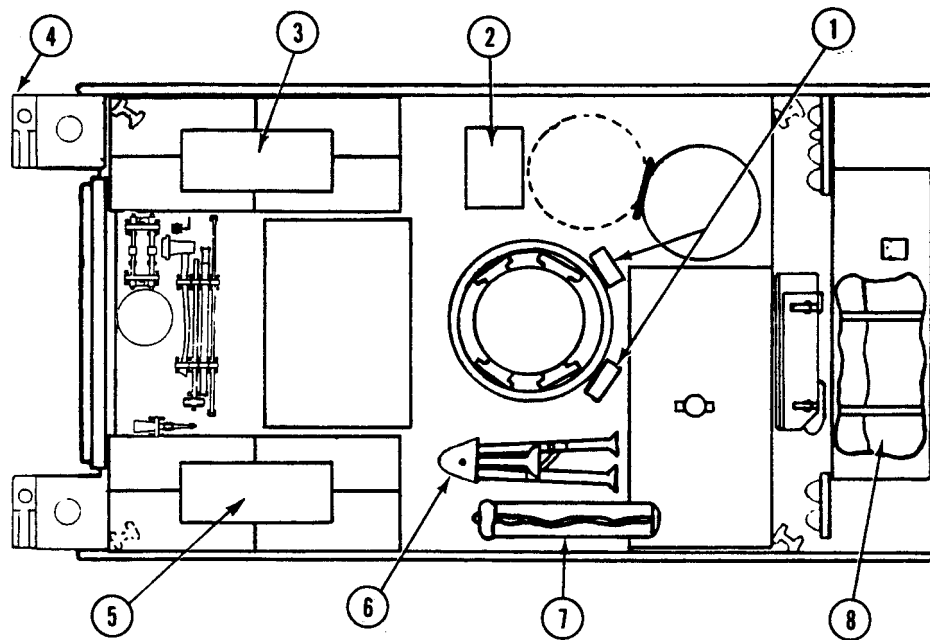
STANDARD LOAD PLAN — M113A3 CARRIERS**EXTERNAL**

1. Ammo cans, cal .50 (2 ea)
2. MRE (2 ea)
3. Duffel bags (5 ea)
4. Water can
5. Duffel bags (5 ea)
6. Tripod, cal .50
7. Camouflage support system
8. Camouflage screen

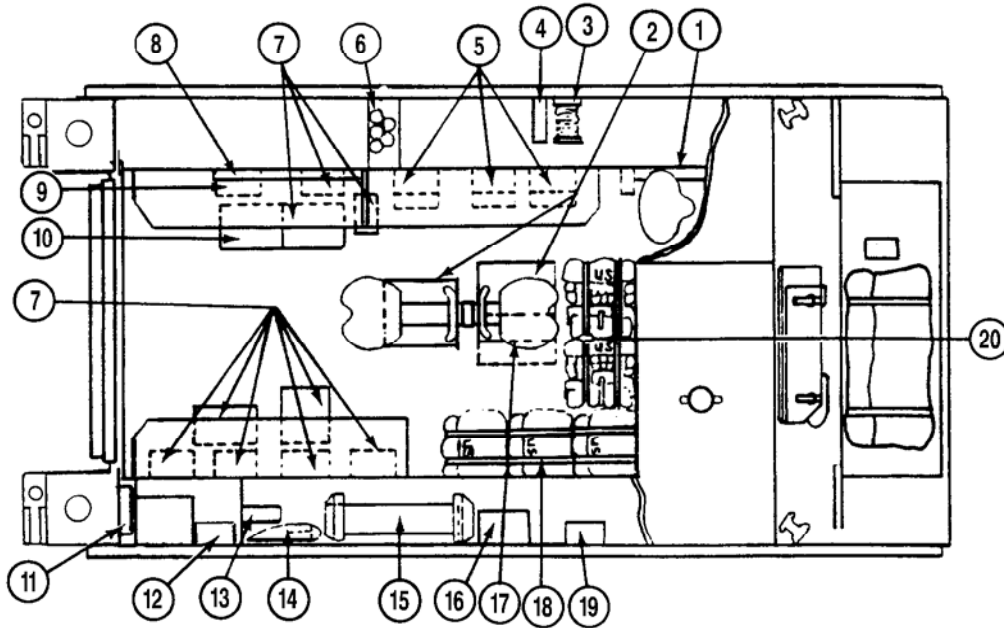

INTERNAL

1. Map canister
2. MRE (4 ea), 3 under TC seat and 1 under SL seat
3. WD-1/TT, DR-8, 1320 ft
4. Binoculars
5. Ammo cans, cal .50 & 7.62 (3 ea)
6. AT4 (3 ea)
7. Ammo cans, cal .50 (6 ea); cases (3 ea)
8. Flag set
9. Ammo can, 5.56 (1 ea)
10. Ammo case, 7.62 (1 ea)
11. Telephone set, TA-1 or TA-312
12. Night vision sight, AN/TVS-2B
13. Ammo can w/cal .50 cleaning rod and case: T&E mech, cal .50
14. M60 spare barrel bag W/T&E mech
15. Javelin missile or 4 LAWs
16. M21 mine box (for mines, flares, booby traps)
17. Night vision goggles (PVS-5) sight (PVS-4)
18. Rucksacks (6 ea)
19. Dragon tracker and device box
20. Rucksacks (4 ea)

STANDARD LOAN PLAN — M1064A3 MORTAR CARRIER

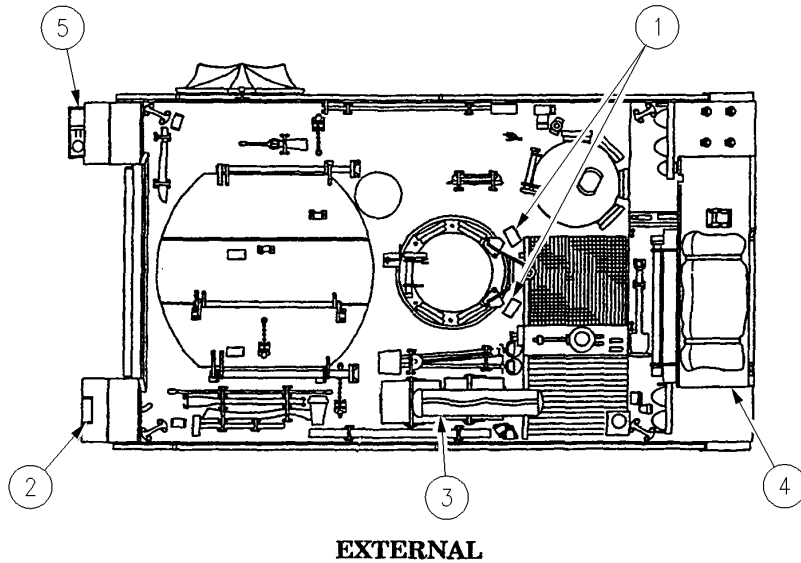

1. Ammo cans, cal .50 (2 ea)
2. WD-1/TT, DR-8, 1320 ft
3. Camouflage support system
4. Camouflage support screen
5. M13 Decon kit

STANDARD LOAN PLAN — M1064A3 MORTAR CARRIER

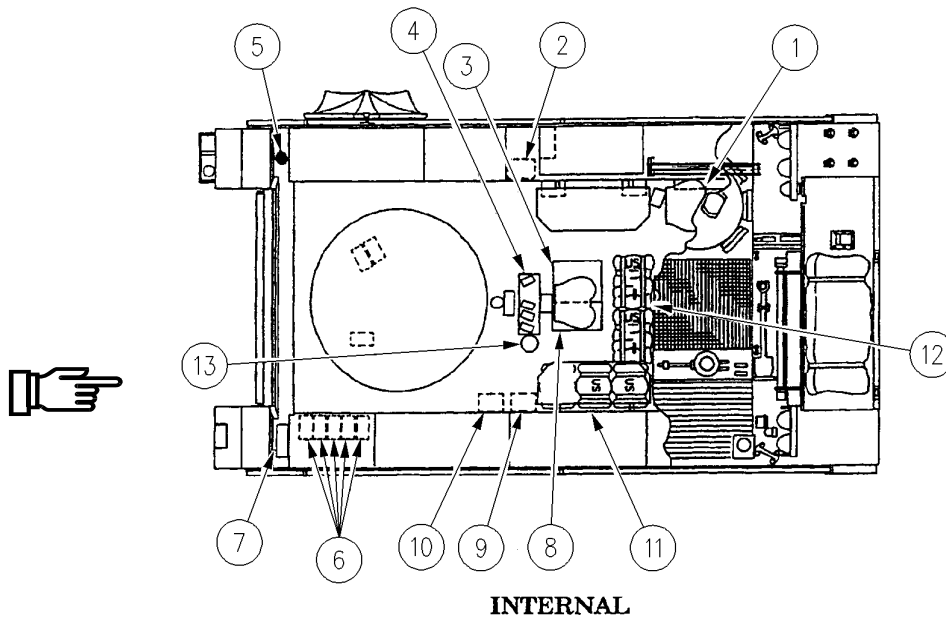

1. Map canister
2. Ammo can, 5.56/cal .45 (1 ea)
3. MRE-ration cases (3 ea)
4. Tripod, aiming circle
5. Flag set
6. Ammo can, cal .50 (6 ea)
7. Telephone set, TA-1 or TA-312
8. Night vision goggles, (PVS-5)/sight (PSV-4)
9. Ammo can v/cal .50 cleaning rod and case: T&E mech, cal .50
10. M67 or M53 sight gear
11. Duffle bags (2 ea)
12. Duffle bags (2 ea)
13. Spare barrel, cal .50

PLUG/SETSCREW GUIDE FOR ARMOR MOUNTING PROVISION HOLES

0107 00

INTRODUCTION

This work package shows the location of plugs and setscrews in armor mounting provision holes in the M113A3 carrier.

PROTECTIVE PLUGS FOR ARMOR MOUNTING PROVISION HOLES

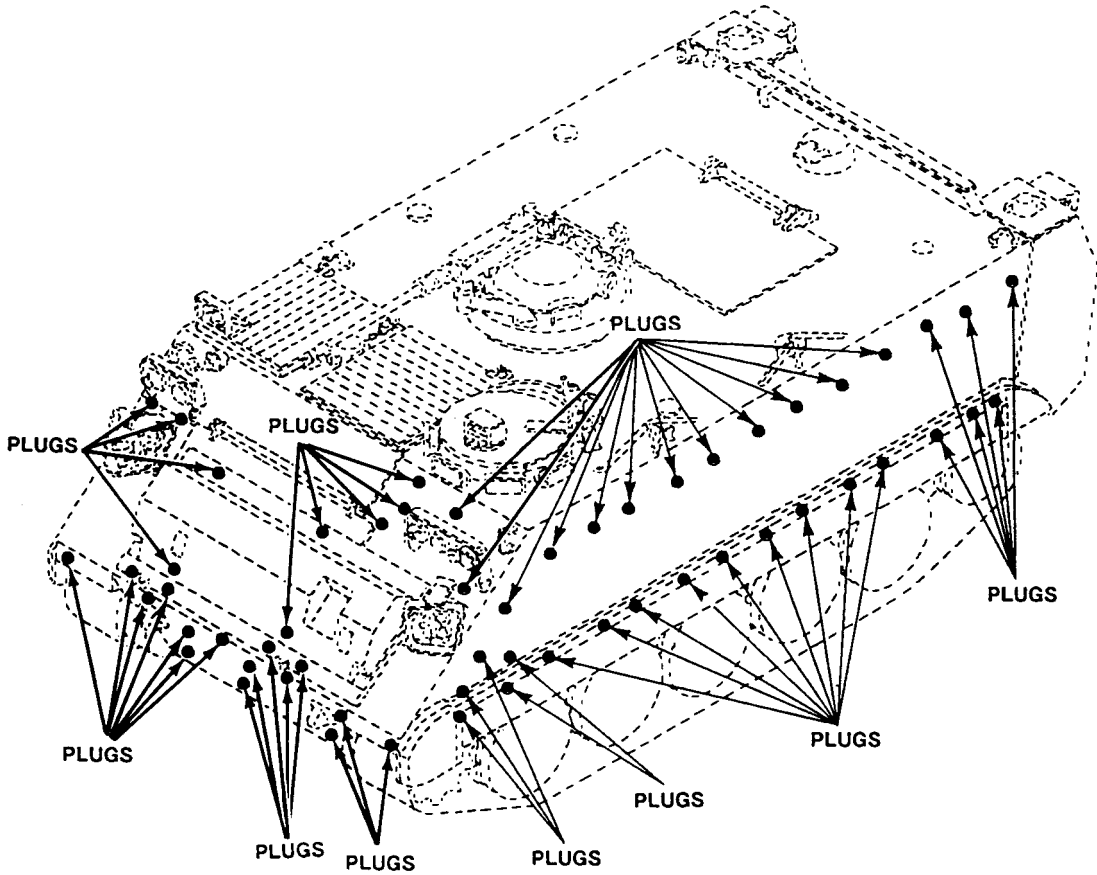

CARRIER FRONT AND SIDES

NOTE

The left side of the carrier is shown. There are corresponding plugs on the right side of the carrier.

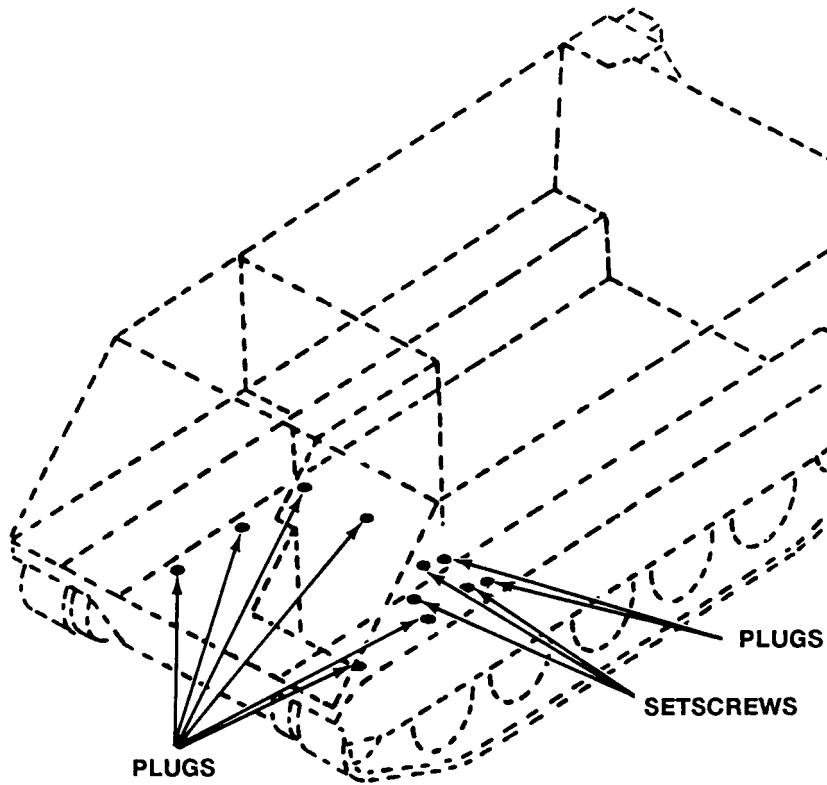

CARRIER BOTTOM

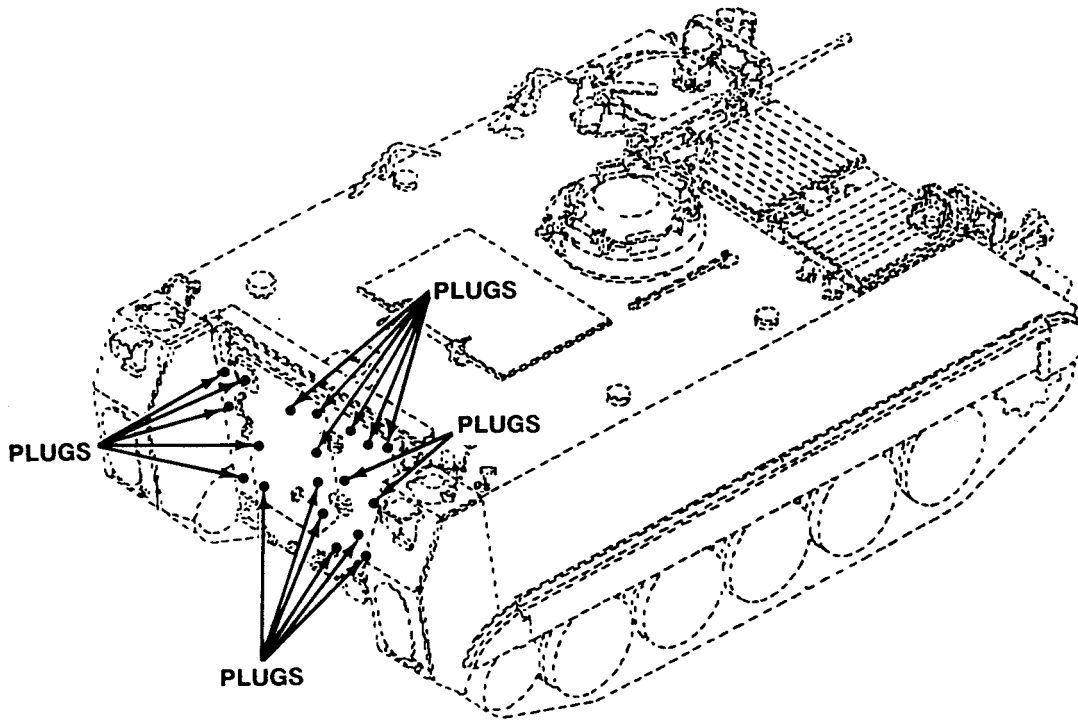

CARRIER BACK

INDEX

<u>Subject</u>	<u>WP Sequence No.-Page No.</u>
A	
Access Door, Power Plant	
Close	0011 00-3
Open	0011 00-1
Access Panels, Power Plant	
Installation	0040 00-2
Removal	0040 00-1
Additional Authorization List (AAL)	0103 00-1
Air Cleaner	
Operational Check	0098 00-1
AN/VAS-5 Driver's Vision Enhancer (DVE)	
Installation	0035 01-1
Removal	0035 01-3
AN/VVS-2(V)1A, Driver's Night Vision	
Installation	0034 00-1
Operate Driver's Night Vision with 2.7 Volt Battery	0035 00-4
Operate Driver's Night Vision with Carrier Power	0035 00-1
Removal	0034 00-4
Armor	
Plug/Setscrew Guide for Mounting Provision Holes	0107 00-1
Auxiliary Power Unit, 5.0 KW Generator	
Operate	0045 00-1
B	
Batteries, Carrier	
Operational Check	0095 00-1
Bilge Pumps	
Operational Check	0096 00-6
Servicing Front Bilge Pump	0096 00-1
Servicing Rear Bilge Pump	0096 00-4
Troubleshooting	0088 00-1
Blackout Curtain, Driver's	
Installation	0050 00-1
Removal	0050 00-1
C	
Carrier	
Connect Trailer	0079 00-1
Disconnect Trailer	0079 00-4

INDEX, cont'd

<u>Subject</u>	<u>WP Sequence No.-Page No.</u>
Do's and Don'ts for Operation in Extreme Cold	0061 00-5
Drive	0023 00-6
Drive On Grades	0073 00-4
Drive On Snow, Ice, or Mud	0073 00-5
Drive Over Obstacles	0073 00-3
Drive Over Trenches	0073 00-2
Driving Precautions	0023 00-3
Ford Water Up to 40 Inches Deep	0064 00-1
Fuel	0025 00-1
Install Tow Bar on Disabled Carrier and Recovery Vehicle	0077 00-2
Install Tow Cables on Disabled Carrier and Recovery Vehicle	0077 00-3
Operate Blackout Dome Lights	0030 00-7
Operate Blackout Marker	0030 00-2
Operate Blackout Marker and Blackout Driving Lights	0030 00-2
Operate Headlights	0030 00-1
Operate in Extreme Cold	0061 00-2
Operate in Extreme Heat, Humidity, or Salty Conditions	0074 00-2
Operate Infrared Headlights	0030 00-4
Operate Panel and Transmission Controller Lights	0030 00-5
Operate Stoplight	0030 00-3
Operate White Dome Lights	0030 00-6
Perform Post-Fording Operations	0065 00-1
Prepare to Operate in Extreme Cold	0061 00-1
Refuel	0026 00-1
Remove Tow Bar from Disabled Carrier and Recovery Vehicle	0077 00-5
Remove Tow Cables from Disabled Carrier and Recovery Vehicle	0077 00-6
Tow Start	0078 00-1
 Cold Start System (Manual Override), Glow Plug	
Operate	0086 00-1
 Command Post System, Modular (MCPS)	
Add Additional Tents	0057 00-1
Dismantle/Stow MCPS	0057 00-1
Set Up MCPS	0057 00-1
 Command Post Tent	
Add Additional Tents	0056 00-4
Dismantle	0059 00-1
Set-Up	0056 00-1
Stow	0059 00-1
 Commander's Cupola	
Operate	0010 00-1
 Commander's Hatch	
M113A3, M1059A3, M1064A3, and M58	
Close	0009 00-2
Open	0009 00-1
M577A3 and M1068A3	
Close	0046 00-2
Open	0046 00-1

INDEX, cont'd

<u>Subject</u>	<u>WP Sequence No.-Page No.</u>
Commander's Platform	
Adjust	0047 00-1
Lower	0047 00-1
Stow	0047 00-1
Commander's Seat	
Adjust	0015 00-1
Stow	0016 00-1
Unstow	0016 00-2
Coolant Heater	
Turn Off Below -25 Degrees	0062 00-3
Turn On Below -25 Degrees	0062 00-1
Cooling System	
Operational Check	0097 00-1
CVC Helmet	
Connect to Intercom Control Box	0018 00-1
Connect to Vehicle Intercommunications System (VIS)	0019 00-1
D	
Description and Use of Operator's Controls and Indicators	0004 00-1
Door, Ramp Access	
Close From Inside Carrier	0005 00-2
Close From Outside Carrier	0005 00-4
Open From Inside Carrier	0005 00-1
Open From Outside Carrier	0005 00-3
Driver's Blackout Curtain	
Installation	0050 00-1
Removal	0050 00-1
Driver's Hatch	
M113A3, M1059A3, M1064A3, and M58	
Close	0006 00-2
Open	0006 00-1
M577A3 and M1068A3 Only	
Close	0048 00-2
Open	0048 00-1
Driver's Lap Seat Belt and Shoulder Harness	
Adjust	0014 00-1
Driver's Night Vision, AN/VVS-2(V)1A	
Installation	0034 00-1

INDEX, cont'd

<u>Subject</u>	<u>WP Sequence No.-Page No.</u>
Operate Driver's Night Vision with 2.7 Volt Battery	0035 00-4
Operate Driver's Night Vision with Carrier Power	0035 00-1
Removal	0034 00-4
 Driver's Seat	
Move Front or Rear	0013 00-3
Raise or Lower	0013 00-1
 Driver's Vision Enhancer (DVE) AN/VAS-5	
Installation	0035 01-1
Removal	0035 01-4
 Driver's Vision Enhancer (DVE), AN/VAS-5	
Driver's/Commander's Display	
Installation	0035 03-6
Removal	0035 03-1
Operate	0035 02-3
Preparation	0035 02-1
Shutdown	0035 02-8
 Driver's/Commander's Display (DVE)	
Installation	0035 03-6
Removal	0035 03-1
 Driving	
On Grades	0073 00-4
On Snow, Ice, or Mud	0073 00-5
Over Obstacles	0073 00-3
Over Trenches	0073 00-2
 Drop Leaf Tables	
Lower	0049 00-1
Raise	0049 00-1
 E	
Electrical System, Troubleshooting	0088 00-1
 Engine	
Coolant Heater	
Troubleshooting	0088 00-1
Prepare to Start	0021 00-1
Start -25 Degrees to 40 Degrees	0021 00-10
Start Above 40 Degrees	0021 00-8
Start with Outside Power Source	0022 00-1
Stop	0024 00-1
Troubleshooting	0088 00-1
 Equipment Description	
Carriers	0002 00-1
Differences Between Carriers	0002 00-59

INDEX, cont'd

<u>Subject</u>	<u>WP Sequence No.-Page No.</u>
Equipment Data	0002 00-60
Location and Descriptions of Major Components	0002 00-28
Locational Terms	0002 00-1
M1059A3 Full Tracked Smoke Generator Carrier	0002 00-22
M1064A3 Mortar Carrier	0002 00-18
M1068A3 Standardized Integrated Command Post System	0002 00-11
M113A3 Full Tracked Armored Personnel Carrier	0002 00-2
M577A3 Command Post Carrier	0002 00-7
M58 Mechanized Smoke Obscurant Carrier	0002 00-25
Material Used with Carriers	0002 00-46
Peculiar Components	0002 00-1
Exhaust Grill	
Cover	0083 00-2
Uncover	0083 00-4
Expendable/Durable Supplies and Materials List	0104 00-1
F	
Final Drive	
Troubleshooting	0088 00-1
Fixed Fire Extinguisher System	
Operate	
Inside	0031 00-2
Outside	0031 00-1
Fuel Carrier	0025 00-1
G	
Gas Particulate Filter Unit, NBC System	
Operate	0081 00-1
Turn NBC Kit Off in Ambulance With Litter Kit	0080 00-3
Turn NBC Kit Off in Ambulance Without Litter Kit	0080 00-6
Turn NBC Kit On in Ambulance With Litter Kit	0080 00-1
Turn NBC Kit On in Ambulance Without Litter Kit	0080 00-4
General Information	
Destruction of Army Materiel to Prevent Enemy Use	0001 00-1
List of Abbreviations/Acronyms	0001 00-2
Maintenance Forms, Records, and Reports	0001 00-1
Nomenclature Cross-Reference	0001 00-1
Reporting Equipment Improvement Recommendations (EIR)	0001 00-1
Safety, Care, and Handling	0001 00-3
Scope	0001 00-1
Generator Set	
Installation	0054 00-3
Operate	0055 00-1
Refuel	0060 00-1
Removal	0054 00-1

INDEX, cont'd

<u>Subject</u>	<u>WP Sequence No.-Page No.</u>
Glow Plug Cold Start System (Manual Override)	
Operate	0086 00-1
Gun, Machine	
Installation	0036 00-1
Removal	0036 00-3
Secure for Travel	0037 00-1
Secure to Armor Shield for Travel	0038 00-1
 H 	
Hatch	
Commander's	
M113A3, M1059A3, M1064A3, and M58	
Close	0009 00-2
Open	0009 00-1
M577A3 and M1068A3	
Close	0046 00-2
Open	0046 00-1
Driver's	
M113A3, M1059A3, M1064A3, and M58	
Close	0006 00-2
Open	0006 00-1
M577A3 and M1068A3 Only	
Close	0048 00-2
Open	0048 00-1
Hatch Cover	
Cargo	
Close	0008 00-2
Open	0008 00-1
Mortar	
Close	0052 00-2
Open	0052 00-1
Heater, Water/Ration	
Installation	0043 00-1
Operate	0044 00-1
Removal	0043 00-2
 I 	
Intake Grill	
Cover	0083 00-3
Uncover	0083 00-5
Intercom Control Box	
Connect CVC Helmet to	0018 00-1

INDEX, cont'd

<u>Subject</u>	<u>WP Sequence No.-Page No.</u>
J	
Jump Seat	
Stow	0017 00-1
Unstow	0017 00-2
L	
Lights	
Operate Blackout Dome Lights	0030 00-7
Operate Blackout Marker	0030 00-2
Operate Blackout Marker and Blackout Driving Lights	0030 00-2
Operate Headlights	0030 00-1
Operate Infrared Headlights	0030 00-4
Operate Panel and Transmission Controller Lights	0030 00-5
Operate Stoplight	0030 00-3
Operate White Dome Lights	0030 00-6
M	
M17 Periscopes	
Installation	0033 00-1
Removal	0033 00-3
Machine Gun	
Installation	0036 00-1
Removal	0036 00-3
Secure for Travel	0037 00-1
Secure to Armor Shield for Travel	0038 00-1
Map Table and Board	
M1068A3 Only	
Stow Map Board	0051 00-4
Unstow Map Board	0051 00-4
M577A3 Only	
Stow Map Board	0051 00-3
Stow Map Table	0051 00-3
Unstow Map Board	0051 00-2
Unstow Map Table	0051 00-1
Modular Command Post System (MCPS)	
Add Additional Tents	0057 00-1
Dismantle/Stow MCPS	0057 00-1
Set Up MCPS	0057 00-1
Mortar Fire Control System	
Installation of MFCS Equipment	0086 01-1

INDEX, cont'd

<u>Subject</u>	<u>WP Sequence No.-Page No.</u>
N	
NBC KIT	
Troubleshooting	0088 00-1
NBC, Gas Particulate Filter Unit	
Operate	0081 00-1
Turn NBC Kit Off in Ambulance With Litter Kit	0080 00-3
Turn NBC Kit Off in Ambulance Without Litter Kit	0080 00-6
Turn NBC Kit On in Ambulance With Litter Kit	0080 00-1
Turn NBC Kit On in Ambulance Without Litter Kit	0080 00-4
O	
Operate Carrier in Extreme Heat, Humidity, or Salty Conditions	0074 00-2
Operator's Controls and Indicators	
Description and Use	0004 00-1
P	
Parking Brake	
Release	0020 00-2
Set	0020 00-1
Personnel Compartment Ventilator	
Operate	0029 00-1
Personnel Heater	
Troubleshooting	0088 00-2
Turn Off	0028 00-4
Turn On	0028 00-1
Platform, Commander's	
Adjust	0047 00-1
Lower	0047 00-1
Stow	0047 00-1
Plug	
Installation	0099 00-1
Removal	0099 00-1
Plug/Setscrew Guide for Armor Mounting Provision Holes	0107 00-1
Portable Fire Extinguisher	
Operate	0032 00-1
Power Plant	
Access Door	
Close	0011 00-3
Open	0011 00-1

INDEX, cont'd

<u>Subject</u>	<u>WP Sequence No.-Page No.</u>
Access Panels	
Installation	0040 00-2
Removal	0040 00-1
Preventive Maintenance Checks and Services (PMCS)	
Explanation of Table Entries	0090 00-2
Maintenance Forms and Records	0090 00-1
PMCS General Instructions	0090 00-2
Scope	0090 00-1
Warnings and Cautions	0090 00-1
Pumps, Bilge	
Operational Check	0096 00-6
Servicing Front Bilge Pump	0096 00-1
Servicing Rear Bilge Pump	0096 00-4
R	
Ramp	
Lower	0012 00-1
Raise	0012 00-2
Securing Inoperable/Unsafe	0076 00-1
References	
Field Manuals	0101 00-1
Forms	0101 00-1
Lubrication	0101 00-1
Other Publications	0101 00-4
Scope	0101 00-1
Technical Manuals	0101 00-1
Refuel Carrier	0026 00-1
S	
Smoke Generator	
Install Fuel Can	0100 00-3
Remove Fuel Can	0100 00-1
Service Fog Oil Tank	0100 00-3
Service Fuel Can	0100 00-2
Smoke Grenade Launcher	
Duds	0082 00-9
Launching	0082 00-6
Loading	0082 00-1
Misfires	0082 00-8
Unloading	0082 00-10
Spall Liners	
Positioning for Access to Equipment	0041 00-1

INDEX, cont'd

<u>Subject</u>	<u>WP Sequence No.-Page No.</u>
Standard Loan Plan	0106 00-1
Stowage and Sign Guide	0105 00-1
T	
Tables, Drop Leaf	
Lower	0049 00-1
Raise	0049 00-1
Tent Liner	
Installation	0058 00-1
Removal	0058 00-3
Tent, Command Post	
Add Additional Tents	0056 00-4
Dismantle	0059 00-1
Set-Up	0056 00-1
Stow	0059 00-1
Theory of Operation	0003 00-1
Tow Bar	
Installation	0077 00-2
Removal	0077 00-6
Tow Cables	
Installation	0077 00-3
Removal	0077 00-7
Tow Start Disabled Carrier	0078 00-1
Towing	
Connect Trailer to Carrier	0079 00-1
Disabled Carrier	0077 00-4
Disconnect Trailer from Carrier	0079 00-4
Track	
Block	0042 00-1
T130	
Adjust Tension	0091 00-1
Break	0092 00-1
Join	0092 00-5
T150	
Adjust Tension	0091 01-1
Break	0092 01-1
Join	0092 01-6
Unblock	0042 00-1

INDEX, cont'd

<u>Subject</u>	<u>WP Sequence No.-Page No.</u>
Track Shoe	
T130	
Assembly	0094 01-1
Installation	0093 00-4
Removal	0093 00-1
T150	
Installation	0093 01-2
Removal	0093 01-1
Wear Limits	0094 00-1
Tracks and Suspension	
Troubleshooting	0088 00-2
Transmission	
Controller	
Bypass Defective Transmission Controller	0075 00-1
Troubleshooting	0088 00-2
Trim Vane	
Lower	0039 00-1
Stow	0039 00-2
Troubleshooting	
Introduction	0087 00-1
Symptom Index	
Bilge Pumps	0088 00-1
Electrical System	0088 00-1
Engine	0088 00-1
Engine Coolant Heater	0088 00-1
Final Drive	0088 00-1
NBC Kit	0088 00-1
Personnel Heater	0088 00-2
Tracks and Suspension	0088 00-2
Transmission	0088 00-2
V	
Vehicle Intercommunications System (VIS)	
Connect CVC Helmet to	0019 00-1
W	
Water/Ration Heater	
Installation	0043 00-1
Operate	0044 00-1
Removal	0043 00-2
Wear Limits	
Track Shoe	0094 00-1
Windshield	
Installation	0027 00-1
Removal	0027 00-2

RECOMMENDED CHANGES TO PUBLICATIONS AND BLANK FORMS	Use Part II (<i>reverse</i>) for Repair Parts and Special Tools Lists (RPSTL) and Supply Catalogs/Supply Manuals (SC/SM).	Date 23 JUL 01
For use of this form, see AR 25-30; the proponent agency is ODISC4.		
TO: (<i>Forward to proponent of publication or form</i>) (<i>Include ZIP Code</i>)		FROM: (<i>Activity and location</i>) (<i>include ZIP code</i>) COMMANDER COMPANY A, 216 CAV FORT KNOX, KY 40121

PART I - ALL PUBLICATIONS (EXCEPT RPSTL AND SC/SM) AND BLANK FORMS

PUBLICATION/FORM NUMBER TM 9-2350-277-10	DATE 02 JAN 01	TITLE Operator's Manual for M113 FOV
--	-------------------	---

ITEM	PAGE	PARA	LINE	FIGURE NO.	TABLE	RECOMMENDED CHANGES AND REASON
	0014 00-2					STEP b. THE SCREWS (4) ON BRACKET (2) MUST BE TORQUED PLEASE ADD TORQUE INFORMATION.
	0023 00-34			5 (SH15)		THERE ARE FOUR CLAMPS (144) ON WIRING HARNESS (217), NOT THREE AS SHOWN. PLEASE CORRECT

*Reference to line numbers within the paragraph or subparagraph.

TYPED NAME, GRADE OR TITLE	TELEPHONE EXCHANGE/AUTOVON, PLUS EXTENSION	SIGNATURE

TO: <i>(Forward direct to addressee listed in publication)</i>	FROM: <i>(Activity and location) (Include Zip Code)</i>	DATE
--	---	------

PART II - REPAIR PARTS AND SPECIAL TOOL LISTS AND SUPPLY CATALOGS/SUPPLY MANUALS

PUBLICATION NUMBER			DATE			TITLE		
PAGE NO.	COLM NO.	LINE NO.	NATIONAL STOCK NUMBER	REFERENCE NO.	FIGURE NO.	ITEM NO.	TOTAL NO. OF MAJOR ITEMS SUPPORTED	RECOMMENDED ACTION

PART III - REMARKS *(Any general remarks or recommendations, or suggestions for improvement of publications and blank forms. Additional blank sheets may be used if more space is needed.)*

SAMPLE

TYPED NAME, GRADE OR TITLE	TELEPHONE EXCHANGE/AUTOVON, PLUS EXTENSION	SIGNATURE
----------------------------	--	-----------

TO: <i>(Forward direct to addressee listed in publication)</i>	FROM: <i>(Activity and location) (Include Zip Code)</i>	DATE
--	---	------

PART II - REPAIR PARTS AND SPECIAL TOOL LISTS AND SUPPLY CATALOGS/SUPPLY MANUALS

PUBLICATION NUMBER			DATE			TITLE		
PAGE NO.	COLM NO.	LINE NO.	NATIONAL STOCK NUMBER	REFERENCE NO.	FIGURE NO.	ITEM NO.	TOTAL NO. OF MAJOR ITEMS SUPPORTED	RECOMMENDED ACTION

PART III - REMARKS *(Any general remarks or recommendations, or suggestions for improvement of publications and blank forms. Additional blank sheets may be used if more space is needed.)*

TYPED NAME, GRADE OR TITLE	TELEPHONE EXCHANGE/AUTOVON, PLUS EXTENSION	SIGNATURE
----------------------------	--	-----------

RECOMMENDED CHANGES TO PUBLICATIONS AND BLANK FORMS

For use of this form, see AR 25-30; the proponent agency is ODISC4.

Use Part II (*reverse*) for Repair Parts and Special Tools Lists (RPSTL) and Supply Catalogs/Supply Manuals (SC/SM).

Date

TO: (*Forward to proponent of publication or form*) (*Include ZIP Code*)

FROM: (*Activity and location*) (*include ZIP code*)

PART I – ALL PUBLICATIONS (EXCEPT RPSTL AND SC/SM) AND BLANK FORMS

PUBLICATION/FORM NUMBER

TM 9-2350-277-10

DATE

02 JAN 01

TITLE

Operator's Manual for M113 FOV

ITEM	PAGE	PARA	LINE	FIGURE NO.	TABLE	RECOMMENDED CHANGES AND REASON

**Reference to line numbers within the paragraph or subparagraph.*

TYPED, GRADE OR TITLE

TELEPHONE EXCHANGE/AUTOVON, PLUS EXTENSION

SIGNATURE

TO: <i>(Forward direct to addressee listed in publication)</i>	FROM: <i>(Activity and location) (Include Zip Code)</i>	DATE
--	---	------

PART II - REPAIR PARTS AND SPECIAL TOOL LISTS AND SUPPLY CATALOGS/SUPPLY MANUALS

PUBLICATION NUMBER			DATE			TITLE		
PAGE NO.	COLM NO.	LINE NO.	NATIONAL STOCK NUMBER	REFERENCE NO.	FIGURE NO.	ITEM NO.	TOTAL NO. OF MAJOR ITEMS SUPPORTED	RECOMMENDED ACTION

PART III - REMARKS *(Any general remarks or recommendations, or suggestions for improvement of publications and blank forms. Additional blank sheets may be used if more space is needed.)*

TYPED NAME, GRADE OR TITLE	TELEPHONE EXCHANGE/AUTOVON, PLUS EXTENSION	SIGNATURE
----------------------------	--	-----------

RECOMMENDED CHANGES TO PUBLICATIONS AND BLANK FORMS

For use of this form, see AR 25-30; the proponent agency is ODISC4.

Use Part II (*reverse*) for Repair Parts and Special Tools Lists (RPSTL) and Supply Catalogs/Supply Manuals (SC/SM).

Date

TO: (*Forward to proponent of publication or form*) (*Include ZIP Code*)

FROM: (*Activity and location*) (*include ZIP code*)

PART I - ALL PUBLICATIONS (EXCEPT RPSTL AND SC/SM) AND BLANK FORMS

PUBLICATION/FORM NUMBER

TM 9-2350-277-10

DATE

02 JAN 01

TITLE

Operator's Manual for M113 FOV

ITEM	PAGE	PARA	LINE	FIGURE NO.	TABLE	RECOMMENDED CHANGES AND REASON

**Reference to line numbers within the paragraph or subparagraph.*

TYPED, GRADE OR TITLE

TELEPHONE EXCHANGE/AUTOVON, PLUS EXTENSION

SIGNATURE

TO: <i>(Forward direct to addressee listed in publication)</i>	FROM: <i>(Activity and location) (Include Zip Code)</i>	DATE
--	---	------

PART II - REPAIR PARTS AND SPECIAL TOOL LISTS AND SUPPLY CATALOGS/SUPPLY MANUALS

PUBLICATION NUMBER			DATE			TITLE		
PAGE NO.	COLM NO.	LINE NO.	NATIONAL STOCK NUMBER	REFERENCE NO.	FIGURE NO.	ITEM NO.	TOTAL NO. OF MAJOR ITEMS SUPPORTED	RECOMMENDED ACTION

PART III - REMARKS *(Any general remarks or recommendations, or suggestions for improvement of publications and blank forms. Additional blank sheets may be used if more space is needed.)*

--

TYPED NAME, GRADE OR TITLE	TELEPHONE EXCHANGE/AUTOVON, PLUS EXTENSION	SIGNATURE
----------------------------	--	-----------

By Order of the Secretary of the Army:

Official:



JOEL B. HUDSON

*Administrative Assistant to the
Secretary of the Army*

9913201

ERIC K. SHINSEKI
*General, United States Army
Chief of Staff*

DISTRIBUTION: To be distributed in accordance with the initial distribution requirements for IDN: 371204, requirements for TM 9-2350-277-10.

THE METRIC SYSTEM AND EQUIVALENTS

LINEAR MEASURE

1 Centimeter = 10 Millimeters = 0.01 Meters = 0.3937 Inches
 1 Meter = 100 Centimeters = 1000 Millimeters = 39.37 Inches
 1 Kilometer = 1000 Meters = 0.621 Miles

WEIGHTS

1 Gram = 0.001 Kilograms = 1000 Milligrams = 0.035 Ounces
 1 Kilogram = 1000 Grams = 2.2 Lb.
 1 Metric Ton = 1000 Kilograms = 1 Megagram = 1.1 Short Tons

LIQUID MEASURE

1 Milliliter = 0.001 Liters = 0.0338 Fluid Ounces
 1 Liter = 1000 Milliliters = 33.82 Fluid Ounces

SQUARE MEASURE

1 Sq. Centimeter = 100 Sq. Millimeters = 0.155 Sq. Inches
 1 Sq. Meter = 10,000 Sq. Centimeters = 10.76 Sq. Feet
 1 Sq. Kilometer = 1,000 Sq. Meters = 0.386 Sq. Miles

CUBIC MEASURE

1 Cu. Centimeter = 1000 Cu. Millimeters = 0.06 Cu. Inches
 1 Cu. Meter = 1,000,000 Cu. Centimeters = 35.31 Cu. Feet

TEMPERATURE

$5/9 (^{\circ}\text{F} - 32) = ^{\circ}\text{C}$
 212° Fahrenheit is equivalent to 100° Celsius
 90° Fahrenheit is equivalent to 32.2° Celsius
 32° Fahrenheit is equivalent to 0° Celsius
 $(9/5 \times ^{\circ}\text{C}) + 32 = ^{\circ}\text{F}$

TO CHANGE	TO	MULTIPLY BY
Inches	Centimeters	2.540
Feet	Meters	0.305
Yards	Meters	0.914
Miles	Kilometers	1.609
Square Inches	Square Centimeters	6.451
Square Feet	Square Meters	0.093
Square Yards	Square Meters	0.836
Square Miles	Square Kilometers	2.590
Acres	Square Hectometers	0.405
Cubic Feet	Cubic Meters	0.028
Cubic Yards	Cubic Meters	0.765
Fluid Ounces	Milliliters	29.573
Pints	Liters	0.473
Quarts	Liters	0.946
Gallons	Liters	3.785
Ounces	Grams	28.349
Pounds	Kilograms	0.454
Short Tons	Metric Tons	0.907
Pound-Feet	Newton-Meters	1.356
Pounds per Square Inch	Kilopascals	6.895
Miles per Gallon	Kilometers per Liter	0.425
Miles per Hour	Kilometers per Hour	1.609

TO CHANGE	TO	MULTIPLY BY
Centimeters	Inches	0.394
Meters	Feet	3.280
Meters	Yards	1.094
Kilometers	Miles	0.621
Square Centimeters	Square Inches	0.155
Square Meters	Square Feet	10.764
Square Meters	Square Yards	1.196
Square Kilometers	Square Miles	0.386
Square Hectometers	Acres	2.471
Cubic Meters	Cubic Feet	35.315
Cubic Meters	Cubic Yards	1.308
Milliliters	Fluid Ounces	0.034
Liters	Pints	2.113
Liters	Quarts	1.057
Liters	Gallons	0.264
Grams	Ounces	0.035
Kilograms	Pounds	2.205
Metric Tons	Short Tons	1.102
Newton-Meters	Pound-Feet	0.738
Kilopascals	Pounds per Square Inch	0.145
Kilometers per Liter	Miles per Gallon	2.354
Kilometers per Hour	Miles per Hour	0.621

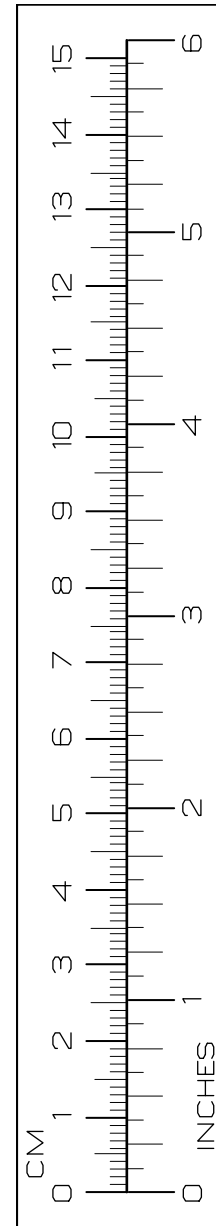

PIN: 062157-000